

# ELECTROMAGNETIC EMISSIONS COMPLIANCE REPORT



**Applicant:** Sonova Consumer Hearing GmbH  
Am Labor 1, 30900 Wedemark, Germany.  
**Manufacturer:** Sonova Consumer Hearing GmbH  
Am Labor 1, 30900 Wedemark, Germany.  
**Product Name:** ACCENTUM True Wireless (ATW1)  
**Brand Name:** SENNHEISER  
**Model No.:** ATW1 (Refer to page 2 for more details)  
**Report Number:** TERF2309002194ER  
**FCC ID** 2A3ULATW1  
**Date of EUT Received:** September 11, 2023  
**Date of Test:** September 11, 2023~September 28, 2023  
**Issue Date:** November 13, 2023

Approved By \_\_\_\_\_

**Jim Chang**

## We hereby certify that:

The above equipment was tested by SGS Taiwan Ltd. Central RF Lab The test data, data evaluation, test procedures, and equipment configurations shown in this report were made in accordance with the procedures given in ANSI C63.10:2013 and the energy emitted by the sample EUT comply with FCC rule part §15.247.

The results of this report relate only to the sample identified in this report.

Unless otherwise stated the results shown in this test report refer only to the sample(s) tested and such sample(s) are retained for 90 days only.

除非另有說明，此報告結果僅對測試之樣品負責，同時此樣品僅保留90天。本報告未經本公司書面許可，不可部份複製。

This document is issued by the Company subject to its General Conditions of Service printed overleaf, available on request or accessible at <http://www.sgs.com.tw/Terms-and-Conditions> and for electronic format documents, subject to Terms and Conditions for Electronic Documents at <http://www.sgs.com.tw/Terms-and-Conditions>. Attention is drawn to the limitation of liability, indemnification and jurisdiction issues defined therein. Any holder of this document is advised that information contained hereon reflects the Company's findings at the time of its intervention only and within the limits of Client's instructions, if any. The Company's sole responsibility is to its Client and this document does not exonerate parties to a transaction from exercising all their rights and obligations under the transaction documents. This document cannot be reproduced except in full, without prior written approval of the Company. Any unauthorized alteration, forgery or falsification of the content or appearance of this document is unlawful and offenders may be prosecuted to the fullest extent of the law.

Revision History					
Report Number	Revision	Description	Issue Date	Revised By	Remark
TERF2309002194ER	00	Original	November 13, 2023	Violetta Tang	

**Note:**

- 1、The remark "" indicates modification of the report upon requests from certification body.
- 2、The EUT system ACCENTUM True Wireless (ATW1) contain the following devices:

Item	Brand Name	Device Model No.
Right Earbud	SENNHEISER	ATW1 R
Left Earbud	SENNHEISER	ATW1 L
Charging Case	SENNHEISER	ATW1 C

- \* ATW1 R and ATW1 L with BT & BT LE TX/RX function
- \* Charging case is solely used for charging ATW1 R and ATW1 L only.
- 3、Variant information of main 1<sup>st</sup> and 2<sup>nd</sup> source is provided by the applicant, test results of this report are applicable to the sample EUT(s) received.

Unless otherwise stated the results shown in this test report refer only to the sample(s) tested and such sample(s) are retained for 90 days only.

除非另有說明，此報告結果僅對測試之樣品負責，同時此樣品僅保留90天。本報告未經本公司書面許可，不可部份複製。

This document is issued by the Company subject to its General Conditions of Service printed overleaf, available on request or accessible at <http://www.sgs.com.tw/Terms-and-Conditions> and for electronic format documents, subject to Terms and Conditions for Electronic Documents at <http://www.sgs.com.tw/Terms-and-Conditions>. Attention is drawn to the limitation of liability, indemnification and jurisdiction issues defined therein. Any holder of this document is advised that information contained hereon reflects the Company's findings at the time of its intervention only and within the limits of Client's instructions, if any. The Company's sole responsibility is to its Client and this document does not exonerate parties to a transaction from exercising all their rights and obligations under the transaction documents. This document cannot be reproduced except in full, without prior written approval of the Company. Any unauthorized alteration, forgery or falsification of the content or appearance of this document is unlawful and offenders may be prosecuted to the fullest extent of the law.

## Contents

<b>1</b>	<b>GENERAL INFORMATION .....</b>	<b>4</b>
<b>2</b>	<b>SYSTEM TEST CONFIGURATION .....</b>	<b>7</b>
<b>3</b>	<b>SUMMARY OF TEST RESULTS.....</b>	<b>10</b>
<b>4</b>	<b>DESCRIPTION OF TEST MODES .....</b>	<b>11</b>
<b>5</b>	<b>MEASUREMENT UNCERTAINTY .....</b>	<b>14</b>
<b>6</b>	<b>MEASUREMENT EQUIPMENT USED.....</b>	<b>15</b>
<b>7</b>	<b>CONDUCTED EMISSION TEST .....</b>	<b>16</b>
<b>8</b>	<b>PEAK OUTPUT POWER MEASUREMENT.....</b>	<b>22</b>
<b>9</b>	<b>EMISSION BANDWIDTH MEASUREMENT .....</b>	<b>24</b>
<b>10</b>	<b>CONDUCTED BAND EDGES AND SPURIOUS EMISSION MEASUREMENT .....</b>	<b>28</b>
<b>11</b>	<b>RADIATED BANDEDGE AND SPURIOUS EMISSION MEASUREMENT .....</b>	<b>32</b>
<b>12</b>	<b>FREQUENCY SEPARATION .....</b>	<b>75</b>
<b>13</b>	<b>NUMBER OF HOPPING FREQUENCY .....</b>	<b>78</b>
<b>14</b>	<b>TIME OF OCCUPANCY (DWELL TIME).....</b>	<b>80</b>
<b>15</b>	<b>ANTENNA REQUIREMENT .....</b>	<b>85</b>

Unless otherwise stated the results shown in this test report refer only to the sample(s) tested and such sample(s) are retained for 90 days only.  
 除非另有說明，此報告結果僅對測試之樣品負責，同時此樣品僅保留90天。本報告未經本公司書面許可，不可部份複製。

This document is issued by the Company subject to its General Conditions of Service printed overleaf, available on request or accessible at <http://www.sgs.com.tw/Terms-and-Conditions> and for electronic format documents, subject to Terms and Conditions for Electronic Documents at <http://www.sgs.com.tw/Terms-and-Conditions>. Attention is drawn to the limitation of liability, indemnification and jurisdiction issues defined therein. Any holder of this document is advised that information contained hereon reflects the Company's findings at the time of its intervention only and within the limits of Client's instructions, if any. The Company's sole responsibility is to its Client and this document does not exonerate parties to a transaction from exercising all their rights and obligations under the transaction documents. This document cannot be reproduced except in full, without prior written approval of the Company. Any unauthorized alteration, forgery or falsification of the content or appearance of this document is unlawful and offenders may be prosecuted to the fullest extent of the law.

## 1 GENERAL INFORMATION

### 1.1 Product Description

Test Item Description	True Wireless Earphones
Product Name	ACCENTUM True Wireless (ATW1)
Brand Name	SENNHEISER
Serial Number / Status of EUT	Engineering sample
Model No.	ATW1 (Refer to page 2 for more details)
Hardware Version	Earbuds: V04 Charging case: V06
Firmware Version	Earbuds: V4.5.6 Charging case: V011
Power Ratings	Earbuds: 3.7Vdc, 55mAh or 3.66Vdc, 75mAh (from battery) Charging case: 5Vdc, 500 mA (from Type-C USB interface) 3.7Vdc, 400-420 mAh (from battery)
Power Supply (Nominal & Testing)	5Vdc (from Type-C USB interface) 3.7Vdc (from battery)
Cable supplied / Device ports	0.4m shielded USB cable without core
Test Software (Name/Version)	Blue Test/3.3.17.1792

Unless otherwise stated the results shown in this test report refer only to the sample(s) tested and such sample(s) are retained for 90 days only.

除非另有說明，此報告結果僅對測試之樣品負責，同時此樣品僅保留90天。本報告未經本公司書面許可，不可部份複製。

This document is issued by the Company subject to its General Conditions of Service printed overleaf, available on request or accessible at <http://www.sgs.com.tw/Terms-and-Conditions> and for electronic format documents, subject to Terms and Conditions for Electronic Documents at <http://www.sgs.com.tw/Terms-and-Conditions>. Attention is drawn to the limitation of liability, indemnification and jurisdiction issues defined therein. Any holder of this document is advised that information contained hereon reflects the Company's findings at the time of its intervention only and within the limits of Client's instructions, if any. The Company's sole responsibility is to its Client and this document does not exonerate parties to a transaction from exercising all their rights and obligations under the transaction documents. This document cannot be reproduced except in full, without prior written approval of the Company. Any unauthorized alteration, forgery or falsification of the content or appearance of this document is unlawful and offenders may be prosecuted to the fullest extent of the law.

## 1.2 RF Specification

Technology	Bluetooth
Operating Frequency	2402 - 2480MHz (for Frequency Band: 2400-2483.5MHz)
Channel Number	79 channels
Channel Spacing	1 MHz
Channel Bandwidth	79 MHz
Data Transfer Rate	BDR: 1Mbps, EDR: 2Mbps/3Mbps
Modulation Type	GFSK, $\pi/4$ DQPSK, 8DPSK
Transmission Technology	FHSS
Maximum Transmit Power	10.31 dBm
Dwell Time	$\leq 0.4s$
Operating Temperature Range	0°C – +40°C

## 1.3 Antenna Designation

Antenna Type	Freq. (MHz)	Right / Left earbud	Peak Antenna Gain (dBi)
Monopole	2402~2480	Right	-1.3
		Left	0.4

### Note:

1. Pre-scanned was done on the above antennas, measurements were demonstrated by using the antenna with the highest gain as the worst case scenarios.
2. Antenna information is provided by the applicant.

Unless otherwise stated the results shown in this test report refer only to the sample(s) tested and such sample(s) are retained for 90 days only.  
除非另有說明，此報告結果僅對測試之樣品負責，同時此樣品僅保留90天。本報告未經本公司書面許可，不可部份複製。

This document is issued by the Company subject to its General Conditions of Service printed overleaf, available on request or accessible at <http://www.sgs.com.tw/Terms-and-Conditions> and for electronic format documents, subject to Terms and Conditions for Electronic Documents at <http://www.sgs.com.tw/Terms-and-Conditions>. Attention is drawn to the limitation of liability, indemnification and jurisdiction issues defined therein. Any holder of this document is advised that information contained hereon reflects the Company's findings at the time of its intervention only and within the limits of Client's instructions, if any. The Company's sole responsibility is to its Client and this document does not exonerate parties to a transaction from exercising all their rights and obligations under the transaction documents. This document cannot be reproduced except in full, without prior written approval of the Company. Any unauthorized alteration, forgery or falsification of the content or appearance of this document is unlawful and offenders may be prosecuted to the fullest extent of the law.

**1.4 Test Methodology of Applied Standards**

FCC Part 15, Subpart C §15.247  
 FCC KDB 558074 D01 15.247 Meas. Guidance v05r02  
 ANSI C63.10:2013

**1.5 Test Facility**

Laboratory	Test Site Address	Test Site Name	FCC Designation number	IC CAB identifier
SGS Taiwan Ltd. Central RF Lab. (TAF code 3702)	No.134, Wu Kung Road, New Taipei Industrial Park, Wuku District, New Taipei City, Taiwan.	SAC 1	TW0027	TW3702
		SAC 2		
		SAC 3		
		Conduction 1		
		Conducted 1		
		Conducted 2		
		Conducted 3		
		Conducted 4		
		Conducted 5		
	Conducted 6			
	No.2, Keji 1st Rd., Guishan District, Taoyuan City, Taiwan 333	Conduction C	TW0028	
		SAC C		
		SAC D		
		SAC G		
		Conducted A		
		Conducted B		
		Conducted C		
		Conducted D		
		Conducted E		
Conducted F				
Conducted G				

**Note:** Test site name is remarked on the equipment list in each section of this report as an indication where measurements occurred in specific test site and address.

**1.6 Special Accessories**

There is no special accessory used while test was conducted.

**1.7 Equipment Modifications**

There was no modification incorporated into the EUT.

Unless otherwise stated the results shown in this test report refer only to the sample(s) tested and such sample(s) are retained for 90 days only.  
 除非另有說明，此報告結果僅對測試之樣品負責，同時此樣品僅保留90天。本報告未經本公司書面許可，不可部份複製。

This document is issued by the Company subject to its General Conditions of Service printed overleaf, available on request or accessible at <http://www.sgs.com.tw/Terms-and-Conditions>, and for electronic format documents, subject to Terms and Conditions for Electronic Documents at <http://www.sgs.com.tw/Terms-and-Conditions>. Attention is drawn to the limitation of liability, indemnification and jurisdiction issues defined therein. Any holder of this document is advised that information contained hereon reflects the Company's findings at the time of its intervention only and within the limits of Client's instructions, if any. The Company's sole responsibility is to its Client and this document does not exonerate parties to a transaction from exercising all their rights and obligations under the transaction documents. This document cannot be reproduced except in full, without prior written approval of the Company. Any unauthorized alteration, forgery or falsification of the content or appearance of this document is unlawful and offenders may be prosecuted to the fullest extent of the law.

## 2 SYSTEM TEST CONFIGURATION

### 2.1 EUT Configuration

The EUT configuration for testing is installed on RF field strength measurement to meet the Commissions requirement and operating in a manner which intends to maximize its emission characteristics in a continuous normal application.

### 2.2 EUT Exercise

An engineering test mode (software/firmware) that applicant provided was utilized to manipulate the EUT into transmit, selection of the test channel, and modulation scheme.

### 2.3 Test Procedure

#### 2.3.1 Conducted Emissions

The EUT is placed on a table which is 0.8 m above ground plane. Conducted emissions from the EUT measured in the frequency range between 0.15 MHz and 30MHz. The CISPR Quasi-Peak and Average detector mode is employed. The two LISNs provide 50uH/50 ohm of coupling impedance for the measuring instrument. Both lines of the power mains connected to the EUT were checked for maximum conducted interference.

#### 2.3.2 Conducted Test (RF)

The active antenna port of the unlicensed wireless device is connected to the spectrum analyzer with attenuator to protect the instrumentation. If a second antenna port is available, it is tested at one operating frequency, with other port(s) appropriately terminated, to verify it has similar output characteristics as the fully tested port.

#### 2.3.3 Radiated Emissions

The EUT is placed on a turn table. For emissions testing at or below 1 GHz, the table height shall be 0.8 m above the reference ground plane. For emission measurements above 1 GHz, the table height shall be 1.5 m. The turn table shall rotate 360 degrees to determine the position of maximum emission level. EUT is set 3m away from the receiving antenna which varied from 1m to 4m to find out the highest emission. And also, each emission was to be maximized by changing the polarization of receiving antenna both horizontal and vertical. In order to find out the max. emission, the relative positions of this transmitter (EUT) was rotated through three orthogonal axes and measurement procedures for electric field radiated emissions above 1 GHz the EUT measurement is to be made "while keeping the antenna in the 'cone of radiation' from that area and pointed at the area both in azimuth and elevation, with polarization oriented for maximum response." is still within the 3dB illumination BW of the measurement antenna.

Unless otherwise stated the results shown in this test report refer only to the sample(s) tested and such sample(s) are retained for 90 days only.

除非另有說明，此報告結果僅對測試之樣品負責，同時此樣品僅保留90天。本報告未經本公司書面許可，不可部份複製。

This document is issued by the Company subject to its General Conditions of Service printed overleaf, available on request or accessible at <http://www.sgs.com.tw/Terms-and-Conditions> and for electronic format documents, subject to Terms and Conditions for Electronic Documents at <http://www.sgs.com.tw/Terms-and-Conditions>. Attention is drawn to the limitation of liability, indemnification and jurisdiction issues defined therein. Any holder of this document is advised that information contained hereon reflects the Company's findings at the time of its intervention only and within the limits of Client's instructions, if any. The Company's sole responsibility is to its Client and this document does not exonerate parties to a transaction from exercising all their rights and obligations under the transaction documents. This document cannot be reproduced except in full, without prior written approval of the Company. Any unauthorized alteration, forgery or falsification of the content or appearance of this document is unlawful and offenders may be prosecuted to the fullest extent of the law.

## 2.4 Measurement Results Explanation Example

### 2.4.1 Radiated Emission Test Sites For Measurements From 9 kHz To 30 MHz

Radiated emission below 30MHz is measured in a 9m\*6m\*6m semi-anechoic chamber, the measurements correspond to those obtained at an open-field test site.

There is a comparison data of both open-field test site and semi-Anechoic chamber, and the result came out very similar.

### 2.4.2 For all conducted test items:

The offset level is set in the spectrum analyzer to compensate the RF cable loss and attenuation factor between EUT conducted port and spectrum analyzer. With the offset compensation, the spectrum analyzer reading level is exactly EUT RF output level.

Unless otherwise stated the results shown in this test report refer only to the sample(s) tested and such sample(s) are retained for 90 days only.  
除非另有說明，此報告結果僅對測試之樣品負責，同時此樣品僅保留90天。本報告未經本公司書面許可，不可部份複製。

This document is issued by the Company subject to its General Conditions of Service printed overleaf, available on request or accessible at <http://www.sgs.com.tw/Terms-and-Conditions> and for electronic format documents, subject to Terms and Conditions for Electronic Documents at <http://www.sgs.com.tw/Terms-and-Conditions>. Attention is drawn to the limitation of liability, indemnification and jurisdiction issues defined therein. Any holder of this document is advised that information contained hereon reflects the Company's findings at the time of its intervention only and within the limits of Client's instructions, if any. The Company's sole responsibility is to its Client and this document does not exonerate parties to a transaction from exercising all their rights and obligations under the transaction documents. This document cannot be reproduced except in full, without prior written approval of the Company. Any unauthorized alteration, forgery or falsification of the content or appearance of this document is unlawful and offenders may be prosecuted to the fullest extent of the law.



## 2.5 Test Configuration

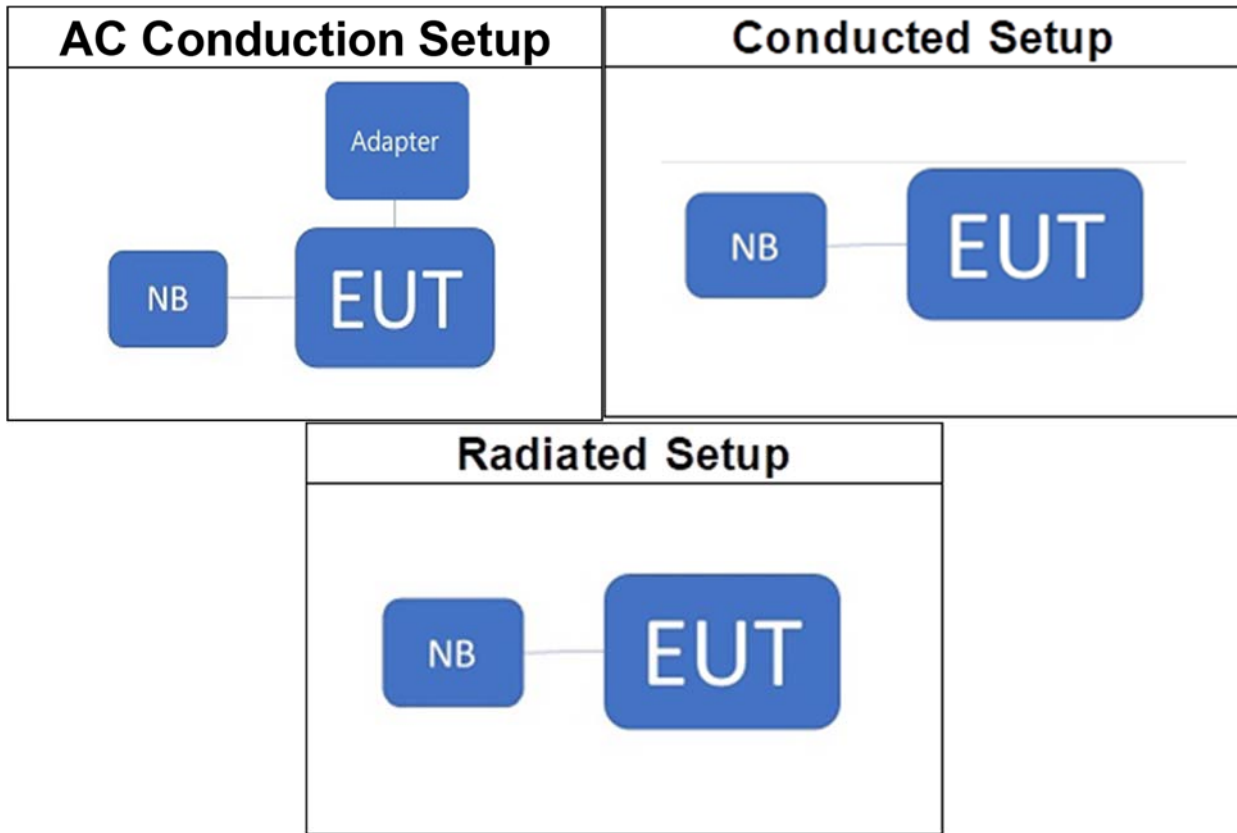

## 2.6 Control Unit(s) lab provided:

AC Power-Line Conducted Emission Test Site: Conduction 1					
EQUIPMENT TYPE	MFR	MODEL NUMBER	SERIAL NUMBER	LAST CAL.	CAL DUE.
Adapter	Apple	A1385	N/A	N/A	N/A
Notebook	HP	HSN-Q35C-4	5CD2428X45	N/A	N/A
Conducted Emission Test Site: Conducted 1					
EQUIPMENT TYPE	MFR	MODEL NUMBER	SERIAL NUMBER	LAST CAL.	CAL DUE.
Notebook	HP	HSN-Q35C-4	5CD238GDV7	N/A	N/A
Radiated Emission Test Site: SAC 1					
EQUIPMENT TYPE	MFR	MODEL NUMBER	SERIAL NUMBER	LAST CAL.	CAL DUE.
Notebook	HP	HSN-Q35C-4	5CD2428X45	N/A	N/A

Unless otherwise stated the results shown in this test report refer only to the sample(s) tested and such sample(s) are retained for 90 days only.

除非另有說明，此報告結果僅對測試之樣品負責，同時此樣品僅保留90天。本報告未經本公司書面許可，不可部份複製。  
 This document is issued by the Company subject to its General Conditions of Service printed overleaf, available on request or accessible at <http://www.sgs.com.tw/Terms-and-Conditions> and for electronic format documents, subject to Terms and Conditions for Electronic Documents at <http://www.sgs.com.tw/Terms-and-Conditions>. Attention is drawn to the limitation of liability, indemnification and jurisdiction issues defined therein. Any holder of this document is advised that information contained herein reflects the Company's findings at the time of its intervention only and within the limits of Client's instructions, if any. The Company's sole responsibility is to its Client and this document does not exonerate parties to a transaction from exercising all their rights and obligations under the transaction documents. This document cannot be reproduced except in full, without prior written approval of the Company. Any unauthorized alteration, forgery or falsification of the content or appearance of this document is unlawful and offenders may be prosecuted to the fullest extent of the law.

### 3 SUMMARY OF TEST RESULTS

FCC Rules	Description Of Test	Result
§15.207(a)	AC Power Line Conducted Emission	Compliant
§15.247(b)(1)	Peak Output Power	Compliant
§15.247(a)(1)	Emission Bandwidth	Compliant
§15.205 §15.209 §15.247(d)	Conducted & Radiated Band Edge and Spurious Emission	Compliant
§15.247(a)(1)	Frequency Separation	Compliant
§15.247(a)(1)(iii)	Number of hopping frequency Time of Occupancy	Compliant
§15.203	Antenna Requirement	Compliant

Unless otherwise stated the results shown in this test report refer only to the sample(s) tested and such sample(s) are retained for 90 days only.

除非另有說明，此報告結果僅對測試之樣品負責，同時此樣品僅保留90天。本報告未經本公司書面許可，不可部份複製。

This document is issued by the Company subject to its General Conditions of Service printed overleaf, available on request or accessible at <http://www.sgs.com.tw/Terms-and-Conditions> and for electronic format documents, subject to Terms and Conditions for Electronic Documents at <http://www.sgs.com.tw/Terms-and-Conditions>. Attention is drawn to the limitation of liability, indemnification and jurisdiction issues defined therein. Any holder of this document is advised that information contained hereon reflects the Company's findings at the time of its intervention only and within the limits of Client's instructions, if any. The Company's sole responsibility is to its Client and this document does not exonerate parties to a transaction from exercising all their rights and obligations under the transaction documents. This document cannot be reproduced except in full, without prior written approval of the Company. Any unauthorized alteration, forgery or falsification of the content or appearance of this document is unlawful and offenders may be prosecuted to the fullest extent of the law.

## 4 DESCRIPTION OF TEST MODES

### 4.1 Operated in 2400 ~ 2483.5MHz Band

2400~2483.5 MHz							
CH	Freq. (MHz)	CH	Freq. (MHz)	CH	Freq. (MHz)	CH	Freq. (MHz)
0	2402	20	2422	40	2442	60	2462
1	2403	21	2423	41	2443	61	2463
2	2404	22	2424	42	2444	62	2464
3	2405	23	2425	43	2445	63	2465
4	2406	24	2426	44	2446	64	2466
5	2407	25	2427	45	2447	65	2467
6	2408	26	2428	46	2448	66	2468
7	2409	27	2429	47	2449	67	2469
8	2410	28	2430	48	2450	68	2470
9	2411	29	2431	49	2451	69	2471
10	2412	30	2432	50	2452	70	2472
11	2413	31	2433	51	2453	71	2473
12	2414	32	2434	52	2454	72	2474
13	2415	33	2435	53	2455	73	2475
14	2416	34	2436	54	2456	74	2476
15	2417	35	2437	55	2457	75	2477
16	2418	36	2438	56	2458	76	2478
17	2419	37	2439	57	2459	77	2479
18	2420	38	2440	58	2460	78	2480
19	2421	39	2441	59	2461		

Unless otherwise stated the results shown in this test report refer only to the sample(s) tested and such sample(s) are retained for 90 days only.

除非另有說明，此報告結果僅對測試之樣品負責，同時此樣品僅保留90天。本報告未經本公司書面許可，不可部份複製。

This document is issued by the Company subject to its General Conditions of Service printed overleaf, available on request or accessible at <http://www.sgs.com.tw/Terms-and-Conditions> and for electronic format documents, subject to Terms and Conditions for Electronic Documents at <http://www.sgs.com.tw/Terms-and-Conditions>. Attention is drawn to the limitation of liability, indemnification and jurisdiction issues defined therein. Any holder of this document is advised that information contained hereon reflects the Company's findings at the time of its intervention only and within the limits of Client's instructions, if any. The Company's sole responsibility is to its Client and this document does not exonerate parties to a transaction from exercising all their rights and obligations under the transaction documents. This document cannot be reproduced except in full, without prior written approval of the Company. Any unauthorized alteration, forgery or falsification of the content or appearance of this document is unlawful and offenders may be prosecuted to the fullest extent of the law.

#### 4.2 The Worst Test Modes and Channel Details

- 1 The EUT has been tested under operating condition.
- 2 Test program used to control the EUT for staying in continuous transmitting and receiving mode is programmed.
- 3 The field strength of radiated emission was measured as the EUT positioned in different orthogonal planes (E1/E2/H) based on actual usage of the EUT to pre-scan the emissions for determining the worst case scenario.
- 4 Investigation has been done on all the possible configurations for searching the worst case.

AC Power Line Conducted Emission				
MODE	AVAILABLE CHANNEL	TESTED CHANNEL	MODULATION	PACKET TYPE
Bluetooth	0 to 78	0	8-DPSK	3DH5 (3M EDR)

ANTNNA PORT CONDUCTED TEST				
MODE	AVAILABLE CHANNEL	TESTED CHANNEL	MODULATION	PACKET TYPE
<b>Peak Output Power, 20dB Band Width, Spurious Emission</b>				
Bluetooth	0 to 78	0,39,78	GFSK	DH5 (BR)
	0 to 78	0,39,78	$\pi/4$ -DQPSK	2DH5 (2M EDR)
	0 to 78	0,39,78	8-DPSK	3DH5 (3M EDR)
<b>Band Edge</b>				
Bluetooth	0 to 78	0,78	GFSK/8-DPSK	DH5 (BR) / 3DH5 (3M EDR)
<b>Frequency Separation</b>				
Bluetooth	0 to 78	0,1,2,38,39,40,76,77,78	GFSK	DH5 (BR)
			$\pi/4$ -DQPSK	2DH5 (2M EDR)
			8-DPSK	3DH5 (3M EDR)
<b>Number of Hopping Frequency, Hopping Band edge</b>				
Bluetooth	0 to 78	0 to 78	GFSK/8-DPSK	DH5 (BR) / 3DH5 (3M EDR)
<b>Time of Occupancy(Dwell time)</b>				
Bluetooth	0 to 78	39	GFSK	DH1 (BR) / DH3 (BR) / DH5 (BR)
			$\pi/4$ -DQPSK	2DH1 (2M EDR) / 2DH3 (2M EDR) / 2DH5 (2M EDR)
			8-DPSK	3DH1 (3M EDR) / 3DH3 (3M EDR) / 3DH5 (3M EDR)

Unless otherwise stated the results shown in this test report refer only to the sample(s) tested and such sample(s) are retained for 90 days only.

除非另有說明，此報告結果僅對測試之樣品負責，同時此樣品僅保留90天。本報告未經本公司書面許可，不可部份複製。

This document is issued by the Company subject to its General Conditions of Service printed overleaf, available on request or accessible at <http://www.sgs.com.tw/Terms-and-Conditions>, and for electronic format documents, subject to Terms and Conditions for Electronic Documents at <http://www.sgs.com.tw/Terms-and-Conditions>. Attention is drawn to the limitation of liability, indemnification and jurisdiction issues defined therein. Any holder of this document is advised that information contained hereon reflects the Company's findings at the time of its intervention only and within the limits of Client's instructions, if any. The Company's sole responsibility is to its Client and this document does not exonerate parties to a transaction from exercising all their rights and obligations under the transaction documents. This document cannot be reproduced except in full, without prior written approval of the Company. Any unauthorized alteration, forgery or falsification of the content or appearance of this document is unlawful and offenders may be prosecuted to the fullest extent of the law.

MODE	AVAILABLE CHANNEL	TESTED CHANNEL	MODULATION	PACKET TYPE
<b>TRANSMIT RADIATED EMISSION TEST (BELOW 1 GHz)</b>				
Bluetooth	0 to 78	39	8-DPSK	3DH5 (3M EDR)
<b>TRANSMIT RADIATED EMISSION TEST (ABOVE 1 GHz)</b>				
Bluetooth	0 to 78	0,39,78	GFSK/8-DPSK	DH5 (BR) / 3DH5 (3M EDR)
<p><b>Note:</b> The field strength of radiation emission was measured as EUT stand-up position (H mode) and lie down position (E1, E2 mode) for channel Low, Mid and High, the worst case position(E2) was reported.</p>				

MODE	AVAILABLE CHANNEL	TESTED CHANNEL	MODULATION	PACKET TYPE
<b>RECEIVE RADIATED EMISSION TEST (BELOW 1 GHz)</b>				
Bluetooth	0 to 78	39	8-DPSK	3DH5 (3M EDR)
<b>RECEIVE RADIATED EMISSION TEST (ABOVE 1 GHz)</b>				
Bluetooth	0 to 78	39	8-DPSK	3DH5 (3M EDR)
<p><b>Note:</b> The field strength of radiation emission was measured as EUT stand-up position (H mode) and lie down position (E1, E2 mode) for channel Low, Mid and High, the worst case position(E2) was reported.</p>				

Unless otherwise stated the results shown in this test report refer only to the sample(s) tested and such sample(s) are retained for 90 days only.

除非另有說明，此報告結果僅對測試之樣品負責，同時此樣品僅保留90天。本報告未經本公司書面許可，不可部份複製。

This document is issued by the Company subject to its General Conditions of Service printed overleaf, available on request or accessible at <http://www.sgs.com.tw/Terms-and-Conditions> and for electronic format documents, subject to Terms and Conditions for Electronic Documents at <http://www.sgs.com.tw/Terms-and-Conditions>. Attention is drawn to the limitation of liability, indemnification and jurisdiction issues defined therein. Any holder of this document is advised that information contained hereon reflects the Company's findings at the time of its intervention only and within the limits of Client's instructions, if any. The Company's sole responsibility is to its Client and this document does not exonerate parties to a transaction from exercising all their rights and obligations under the transaction documents. This document cannot be reproduced except in full, without prior written approval of the Company. Any unauthorized alteration, forgery or falsification of the content or appearance of this document is unlawful and offenders may be prosecuted to the fullest extent of the law.

## 5 MEASUREMENT UNCERTAINTY

Test Items	Uncertainty
AC Power Line Conducted Emission	+/- 2.32 dB
Output Power measurement	+/- 1 dB
Emission Bandwidth	+/- 1.53 Hz
Undesignable radiated emission measurement	+/- 1.68 dB
Frequency Separation	+/- 1.53 Hz
Number of hopping frequency	+/- 1.53 Hz
Time of Occupancy	+/- 1.53 Hz
Temperature	+/- 0.7 °C
Humidity	+/- 3 %
DC / AC Power Source	+/- 1 %

Radiated Spurious Emission Measurement Uncertainty		
<b>Polarization: Vertical</b>	+/- 2.8 dB	9kHz~30MHz
	+/- 4.82 dB	30MHz - 1000MHz
	+/- 4.37 dB	1GHz - 18GHz
	+/- 4.21 dB	18GHz - 40GHz
<b>Polarization: Horizontal</b>	+/- 2.8 dB	9kHz~30MHz
	+/- 4.54 dB	30MHz - 1000MHz
	+/- 4.37 dB	1GHz - 18GHz
	+/- 4.21 dB	18GHz - 40GHz

### Note:

1. This uncertainty represents an expanded uncertainty expressed at approximately the 95% confidence level using a coverage factor of k=2.
2. The conformity assessment statement in this report is based solely on the test results, measurement uncertainty is excluded.

Unless otherwise stated the results shown in this test report refer only to the sample(s) tested and such sample(s) are retained for 90 days only.

除非另有說明，此報告結果僅對測試之樣品負責，同時此樣品僅保留90天。本報告未經本公司書面許可，不可部份複製。

This document is issued by the Company subject to its General Conditions of Service printed overleaf, available on request or accessible at <http://www.sgs.com.tw/Terms-and-Conditions> and for electronic format documents, subject to Terms and Conditions for Electronic Documents at <http://www.sgs.com.tw/Terms-and-Conditions>. Attention is drawn to the limitation of liability, indemnification and jurisdiction issues defined therein. Any holder of this document is advised that information contained hereon reflects the Company's findings at the time of its intervention only and within the limits of Client's instructions, if any. The Company's sole responsibility is to its Client and this document does not exonerate parties to a transaction from exercising all their rights and obligations under the transaction documents. This document cannot be reproduced except in full, without prior written approval of the Company. Any unauthorized alteration, forgery or falsification of the content or appearance of this document is unlawful and offenders may be prosecuted to the fullest extent of the law.

## 6 MEASUREMENT EQUIPMENT USED

### 6.1 Emission from AC power line

AC Power-Line Conducted Emission Test Site: Conduction 1					
EQUIPMENT TYPE	MFR	MODEL NUMBER	SERIAL NUMBER	LAST CAL.	CAL DUE.
Test Software	Audix	e3	Ver. 9.210616	N.C.R	N.C.R
LISN	SCHWARZBECK	NSLK 8127	1040	09/06/2023	09/05/2024
Coaxial Cables	EMC Instruments Corp.	EMCCFD300-BM-BM-3000	161207	06/22/2023	06/21/2024
Pulse Limiter	SCHWARZBECK	VTSD 9561F-N	793	06/22/2023	06/21/2024
EMI Test Receiver	R&S	ESCI 7	100759	08/21/2023	08/20/2024

### 6.2 Conducted Measurement

Conducted Emission Test Site: Conducted 1					
EQUIPMENT TYPE	MFR	MODEL NUMBER	SERIAL NUMBER	LAST CAL.	CAL DUE.
EXA Spectrum Analyzer	KEYSIGHT	N9010B	MY59071571	06/07/2023	06/06/2024
Test Software	SGS	Radio Test Software	Ver. 21	N.C.R	N.C.R
Power Meter	Anritsu	ML2496A	1242004	10/26/2022	10/25/2023
Power Sensor	Anritsu	MA2411B	1207365	10/26/2022	10/25/2023
Power Sensor	Anritsu	MA2411B	1207368	10/26/2022	10/25/2023
DC Block	Mini-Circuits	BLK-18-S+	1	12/13/2022	12/12/2023

### 6.3 Radiated Measurement

Radiated Emission Test Site: SAC 1					
EQUIPMENT TYPE	MFR	MODEL NUMBER	SERIAL NUMBER	LAST CAL.	CAL DUE.
Loop Antenna	ETS.LINDGREN	6502	148045	10/05/2022	10/04/2023
Horn Antenna	RF SPIN	DRH0844	LE2D05A0844	07/03/2023	07/02/2024
Horn Antenna	SCHWARZBECK	BBHA9120D	D803	12/30/2022	12/29/2023
Bi-log Antenna	TESEO	CBL 6112D	35242 & AT-N0555	12/27/2022	12/26/2023
Spectrum Analyzer	Agilent	E4446A	MY51100003	10/28/2022	10/27/2023
Test Software	Audix	e3	Ver. 9.210616	N.C.R	N.C.R
EMI Test Receiver	R&S	ESCI 7	100759	08/21/2023	08/20/2024
Site Cal	SGS	SAC 1	N/A	08/31/2023	08/30/2024
Pre-Amplifier	EMCI	EMC184045B	980135	08/31/2023	08/30/2024
Pre-Amplifier	HP	8447D	2944A09469	08/31/2023	08/30/2024
Pre-Amplifier	EMCI	EMC118A45SEE	980933	07/31/2023	07/30/2024
Bandreject Filter 2400-2483.5	EWT	EWT-14-0166	M1	12/13/2022	12/12/2023
4GHz High Pass Filter	WI	WHKX4.0/18G-10SS	22	12/13/2022	12/12/2023
Coaxial Cables	Huber Suhner	SUCOFLEX 102	RX Cable 18G-40G MY2630/2+805062/2	08/31/2023	08/30/2024
Coaxial Cable	EMCI	EMC104-SM-SM-8000+EMC106-SM-SM-7600	RX Cable 9K-18G(160125+150817)	09/12/2023	09/11/2024

**NOTE:** N.C.R refers to Not Calibrated Required.

Unless otherwise stated the results shown in this test report refer only to the sample(s) tested and such sample(s) are retained for 90 days only.

除非另有說明，此報告結果僅對測試之樣品負責，同時此樣品僅保留90天。本報告未經本公司書面許可，不可部份複製。

This document is issued by the Company subject to its General Conditions of Service printed overleaf, available on request or accessible at <http://www.sgs.com.tw/Terms-and-Conditions> and for electronic format documents, subject to Terms and Conditions for Electronic Documents at <http://www.sgs.com.tw/Terms-and-Conditions>. Attention is drawn to the limitation of liability, indemnification and jurisdiction issues defined therein. Any holder of this document is advised that information contained hereon reflects the Company's findings at the time of its intervention only and within the limits of Client's instructions, if any. The Company's sole responsibility is to its Client and this document does not exonerate parties to a transaction from exercising all their rights and obligations under the transaction documents. This document cannot be reproduced except in full, without prior written approval of the Company. Any unauthorized alteration, forgery or falsification of the content or appearance of this document is unlawful and offenders may be prosecuted to the fullest extent of the law.

## 7 CONDUCTED EMISSION TEST

### 7.1 Standard Applicable

Frequency within 150 kHz to 30MHz shall not exceed the limit table as below.

Frequency range MHz	Limits dB(uV)	
	Quasi-peak	Average
0.15 to 0.50	66 to 56	56 to 46
0.50 to 5	56	46
5 to 30	60	50

Note

- 1.The lower limit shall apply at the transition frequencies
- 2.The limit decreases linearly with the logarithm of the frequency in the range 0.15 MHz to 0.50 MHz.

### 7.2 EUT Setup:

1. The conducted emission tests were performed in the test site, using the setup in accordance with the ANSI C63.10:2013.
2. The AC/DC Power adaptor of EUT was plug-in LISN. The EUT was placed flushed with the rear of the table.
3. The LISN was connected with 120Vac/60Hz power source.

### 7.3 Test Setup

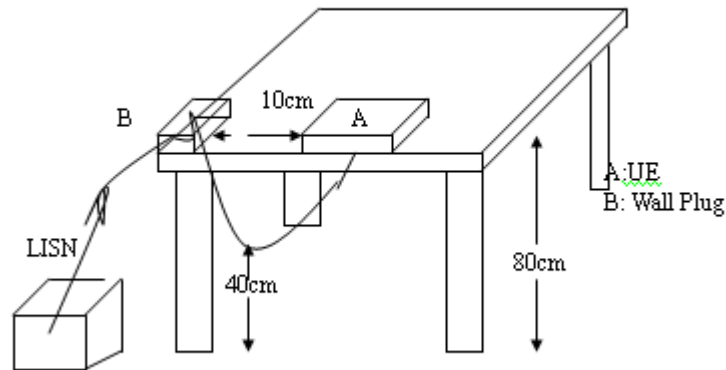

### 7.4 Measurement Procedure

1. The EUT was placed on a table which is 0.8m above ground plane.
2. Maximum procedure was performed on the six highest emissions to ensure EUT compliance.
3. Repeat above procedures until all frequency measured were complete.

Unless otherwise stated the results shown in this test report refer only to the sample(s) tested and such sample(s) are retained for 90 days only.

除非另有說明，此報告結果僅對測試之樣品負責，同時此樣品僅保留90天。本報告未經本公司書面許可，不可部份複製。

This document is issued by the Company subject to its General Conditions of Service printed overleaf, available on request or accessible at <http://www.sgs.com.tw/Terms-and-Conditions> and for electronic format documents, subject to Terms and Conditions for Electronic Documents at <http://www.sgs.com.tw/Terms-and-Conditions>. Attention is drawn to the limitation of liability, indemnification and jurisdiction issues defined therein. Any holder of this document is advised that information contained herein reflects the Company's findings at the time of its intervention only and within the limits of Client's instructions, if any. The Company's sole responsibility is to its Client and this document does not exonerate parties to a transaction from exercising all their rights and obligations under the transaction documents. This document cannot be reproduced except in full, without prior written approval of the Company. Any unauthorized alteration, forgery or falsification of the content or appearance of this document is unlawful and offenders may be prosecuted to the fullest extent of the law.





## 7.5 Measurement Result

Note: Refer to next page for measurement data and plots.

Note2: The \* reveals the worst-case results that closest to the limit.

Unless otherwise stated the results shown in this test report refer only to the sample(s) tested and such sample(s) are retained for 90 days only.  
除非另有說明，此報告結果僅對測試之樣品負責，同時此樣品僅保留90天。本報告未經本公司書面許可，不可部份複製。

This document is issued by the Company subject to its General Conditions of Service printed overleaf, available on request or accessible at <http://www.sgs.com.tw/Terms-and-Conditions> and for electronic format documents, subject to Terms and Conditions for Electronic Documents at <http://www.sgs.com.tw/Terms-and-Conditions>. Attention is drawn to the limitation of liability, indemnification and jurisdiction issues defined therein. Any holder of this document is advised that information contained hereon reflects the Company's findings at the time of its intervention only and within the limits of Client's instructions, if any. The Company's sole responsibility is to its Client and this document does not exonerate parties to a transaction from exercising all their rights and obligations under the transaction documents. This document cannot be reproduced except in full, without prior written approval of the Company. Any unauthorized alteration, forgery or falsification of the content or appearance of this document is unlawful and offenders may be prosecuted to the fullest extent of the law.

### AC POWER LINE CONDUCTED EMISSION TEST DATA

1<sup>st</sup>

Report Number :TERF2309002194ER  
 Operation Mode :BT  
 Power :120V/60Hz  
 Probe :L

Test Site :Conduction 1  
 Test Date :2023-09-19  
 Temp./Humi. :24.8°C/62%  
 Engineer :WJ Lin

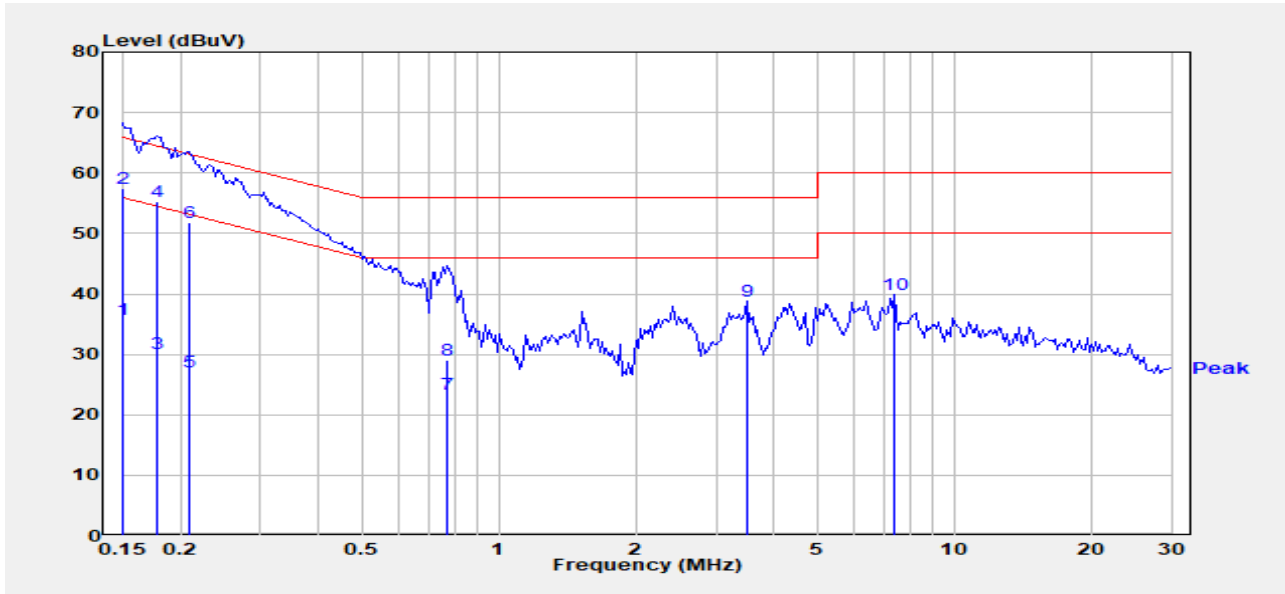

Freq. MHz	Detector Mode PK/QP/AV	Spectrum Reading Level dB $\mu$ V	Factor dB	Actual FS dB $\mu$ V	Limit dB $\mu$ V	Margin dB
0.150	Average	25.60	10.25	35.85	56.00	-20.15
0.150	QP	47.12	10.25	57.37	66.00	-8.63
0.178	Average	19.99	10.25	30.24	54.59	-24.35
0.178	QP	45.01	10.25	55.26	64.59	-9.33
0.208	Average	16.76	10.25	27.01	53.27	-26.26
0.208	QP	41.51	10.25	51.76	63.27	-11.51
0.767	Average	13.11	10.32	23.43	46.00	-22.57
0.767	QP	18.84	10.32	29.16	56.00	-26.84
3.528	Peak	28.10	10.73	38.83	56.00	-17.17
7.407	Peak	29.24	10.60	39.84	60.00	-20.16

Unless otherwise stated the results shown in this test report refer only to the sample(s) tested and such sample(s) are retained for 90 days only.

除非另有說明，此報告結果僅對測試之樣品負責，同時此樣品僅保留90天。本報告未經本公司書面許可，不可部份複製。  
 This document is issued by the Company subject to its General Conditions of Service printed overleaf, available on request or accessible at <http://www.sgs.com.tw/Terms-and-Conditions> and for electronic format documents, subject to Terms and Conditions for Electronic Documents at <http://www.sgs.com.tw/Terms-and-Conditions>. Attention is drawn to the limitation of liability, indemnification and jurisdiction issues defined therein. Any holder of this document is advised that information contained hereon reflects the Company's findings at the time of its intervention only and within the limits of Client's instructions, if any. The Company's sole responsibility is to its Client and this document does not exonerate parties to a transaction from exercising all their rights and obligations under the transaction documents. This document cannot be reproduced except in full, without prior written approval of the Company. Any unauthorized alteration, forgery or falsification of the content or appearance of this document is unlawful and offenders may be prosecuted to the fullest extent of the law.

Report Number :TERF2309002194ER  
 Operation Mode :BT  
 Power :120V/60Hz  
 Probe :N

Test Site :Conduction 1  
 Test Date :2023-09-19  
 Temp./Humi. :24.8°C/62%  
 Engineer :WJ Lin

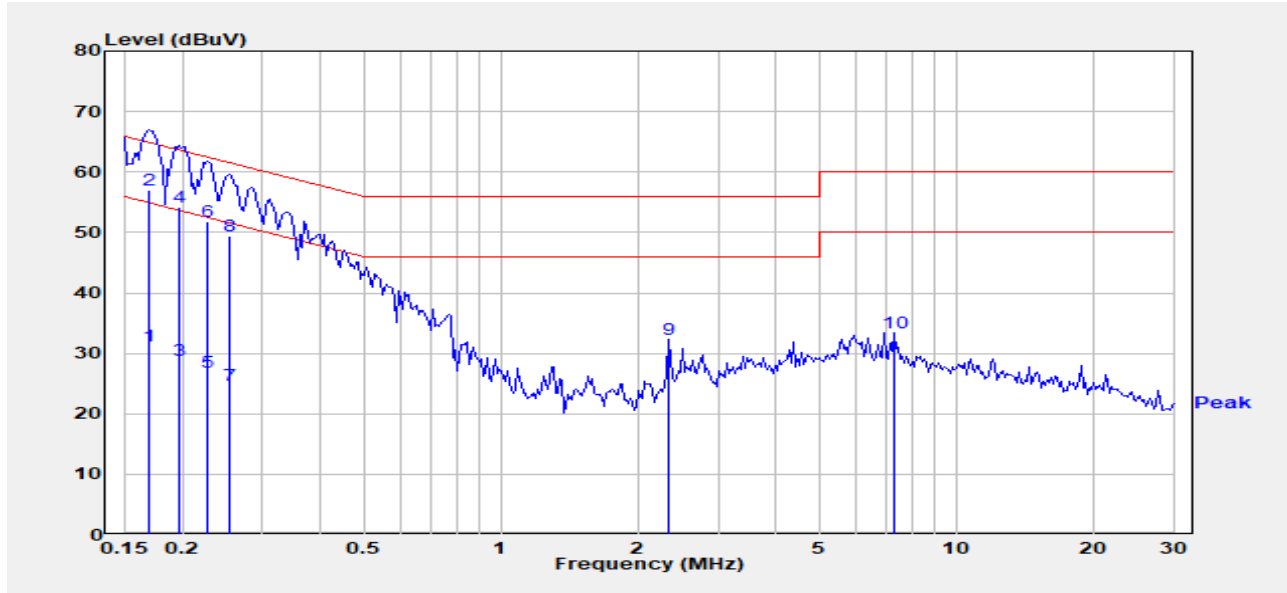

Freq. MHz	Detector Mode PK/QP/AV	Spectrum Reading Level dB $\mu$ V	Factor dB	Actual FS dB $\mu$ V	Limit dB $\mu$ V	Margin dB
0.169	Average	21.11	10.12	31.23	55.03	-23.80
0.169	QP	46.86	10.12	56.98	65.03	-8.05
0.198	Average	18.63	10.12	28.75	53.71	-24.96
0.198	QP	44.07	10.12	54.19	63.71	-9.52
0.227	Average	16.84	10.13	26.97	52.57	-25.60
0.227	QP	41.66	10.13	51.79	62.57	-10.78
0.255	Average	14.65	10.13	24.78	51.60	-26.82
0.255	QP	39.33	10.13	49.46	61.60	-12.14
2.334	Peak	22.09	10.22	32.30	56.00	-23.70
7.329	Peak	23.07	10.38	33.45	60.00	-26.55

Unless otherwise stated the results shown in this test report refer only to the sample(s) tested and such sample(s) are retained for 90 days only.

除非另有說明，此報告結果僅對測試之樣品負責，同時此樣品僅保留90天。本報告未經本公司書面許可，不可部份複製。

This document is issued by the Company subject to its General Conditions of Service printed overleaf, available on request or accessible at <http://www.sgs.com.tw/Terms-and-Conditions> and for electronic format documents, subject to Terms and Conditions for Electronic Documents at <http://www.sgs.com.tw/Terms-and-Conditions>. Attention is drawn to the limitation of liability, indemnification and jurisdiction issues defined therein. Any holder of this document is advised that information contained hereon reflects the Company's findings at the time of its intervention only and within the limits of Client's instructions, if any. The Company's sole responsibility is to its Client and this document does not exonerate parties to a transaction from exercising all their rights and obligations under the transaction documents. This document cannot be reproduced except in full, without prior written approval of the Company. Any unauthorized alteration, forgery or falsification of the content or appearance of this document is unlawful and offenders may be prosecuted to the fullest extent of the law.

Report Number :TERF2309002194ER  
 Operation Mode :BT  
 Power :120V/60Hz  
 Probe :L

Test Site :Conduction 1  
 Test Date :2023-09-28  
 Temp./Humi. :25.1°C/61%  
 Engineer :WJ Lin

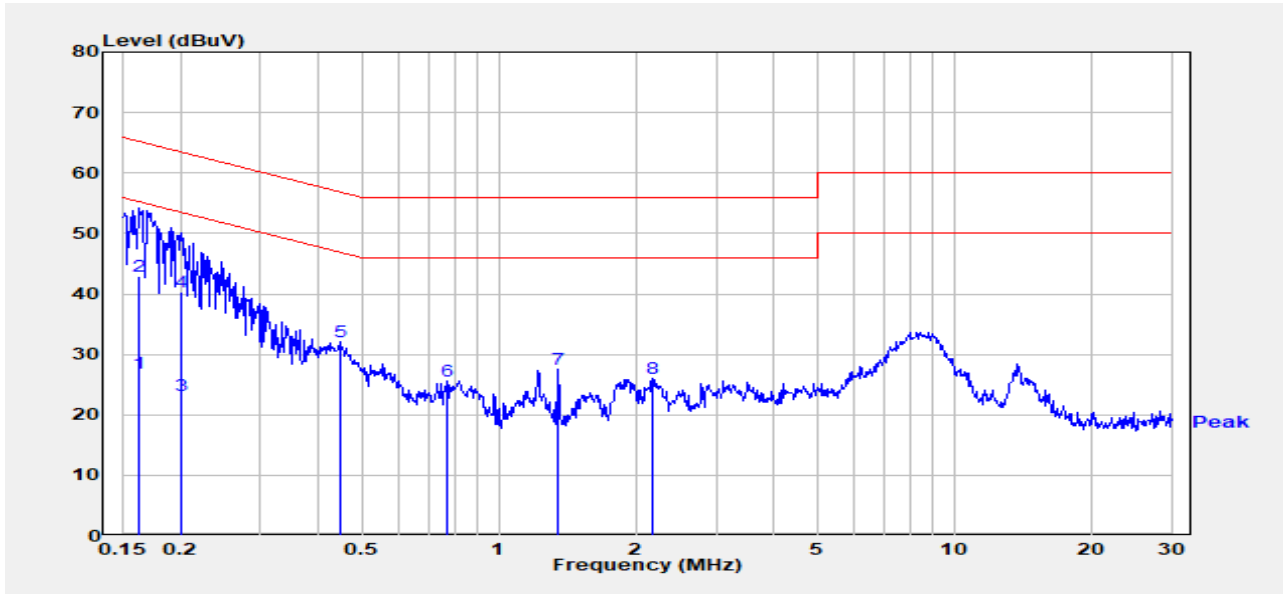

Freq. MHz	Detector Mode PK/QP/AV	Spectrum Reading Level dB $\mu$ V	Factor dB	Actual FS dB $\mu$ V	Limit dB $\mu$ V	Margin dB
0.162	Average	16.80	10.13	26.93	55.38	-28.45
0.162	QP	32.90	10.13	43.03	65.38	-22.35
0.201	Average	13.00	10.13	23.13	53.58	-30.45
0.201	QP	30.10	10.13	40.23	63.58	-23.35
0.447	Peak	22.03	10.16	32.18	56.93	-24.75
0.767	Peak	15.49	10.19	25.67	56.00	-30.33
1.352	Peak	17.44	10.20	27.63	56.00	-28.37
2.178	Peak	15.76	10.20	25.96	56.00	-30.04

Unless otherwise stated the results shown in this test report refer only to the sample(s) tested and such sample(s) are retained for 90 days only.

除非另有說明，此報告結果僅對測試之樣品負責，同時此樣品僅保留90天。本報告未經本公司書面許可，不可部份複製。

This document is issued by the Company subject to its General Conditions of Service printed overleaf, available on request or accessible at <http://www.sgs.com.tw/Terms-and-Conditions> and for electronic format documents, subject to Terms and Conditions for Electronic Documents at <http://www.sgs.com.tw/Terms-and-Conditions>. Attention is drawn to the limitation of liability, indemnification and jurisdiction issues defined therein. Any holder of this document is advised that information contained hereon reflects the Company's findings at the time of its intervention only and within the limits of Client's instructions, if any. The Company's sole responsibility is to its Client and this document does not exonerate parties to a transaction from exercising all their rights and obligations under the transaction documents. This document cannot be reproduced except in full, without prior written approval of the Company. Any unauthorized alteration, forgery or falsification of the content or appearance of this document is unlawful and offenders may be prosecuted to the fullest extent of the law.

Report Number :TERF2309002194ER  
 Operation Mode :BT  
 Power :120V/60Hz  
 Probe :N

Test Site :Conduction 1  
 Test Date :2023-09-28  
 Temp./Humi. :25.1°C/61%  
 Engineer :WJ Lin

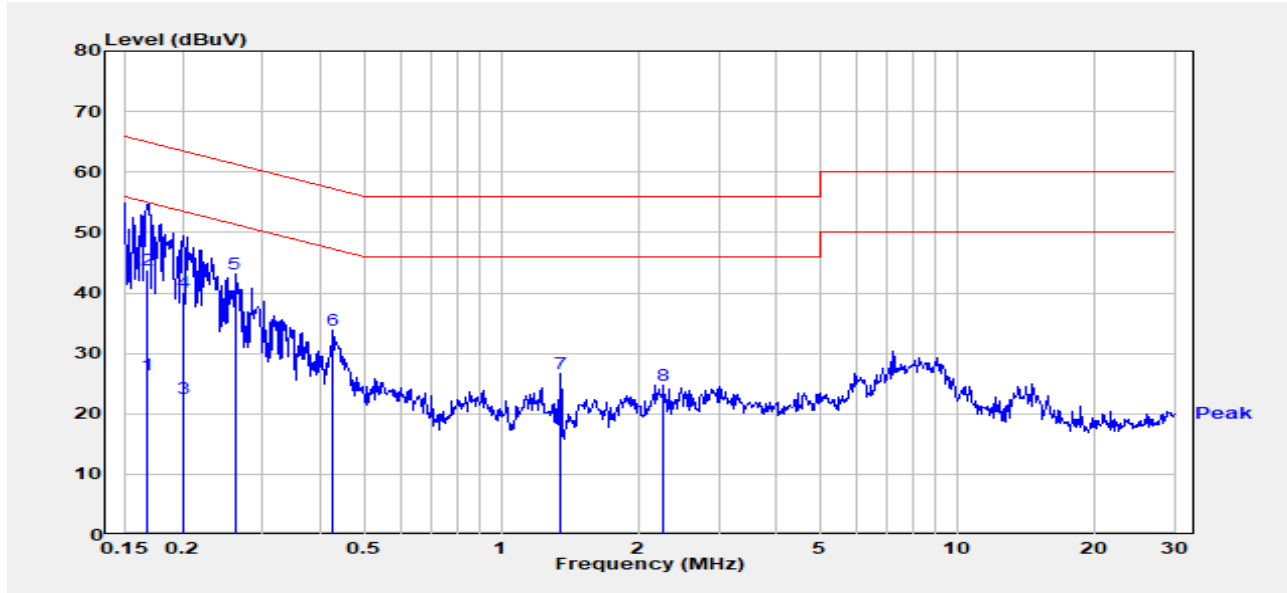

Freq. MHz	Detector Mode PK/QP/AV	Spectrum Reading Level dB $\mu$ V	Factor dB	Actual FS dB $\mu$ V	Limit dB $\mu$ V	Margin dB
0.168	Average	16.30	10.12	26.42	55.08	-28.66
0.168	QP	33.60	10.12	43.72	65.08	-21.36
0.201	Average	12.50	10.12	22.62	53.58	-30.96
0.201	QP	30.00	10.12	40.12	63.58	-23.46
0.260	Peak	32.97	10.13	43.10	61.42	-18.32
0.428	Peak	23.63	10.15	33.79	57.29	-23.50
1.345	Peak	16.41	10.19	26.60	56.00	-29.40
2.273	Peak	14.47	10.21	24.68	56.00	-31.32

Unless otherwise stated the results shown in this test report refer only to the sample(s) tested and such sample(s) are retained for 90 days only.

除非另有說明，此報告結果僅對測試之樣品負責，同時此樣品僅保留90天。本報告未經本公司書面許可，不可部份複製。

This document is issued by the Company subject to its General Conditions of Service printed overleaf, available on request or accessible at <http://www.sgs.com.tw/Terms-and-Conditions> and for electronic format documents, subject to Terms and Conditions for Electronic Documents at <http://www.sgs.com.tw/Terms-and-Conditions>. Attention is drawn to the limitation of liability, indemnification and jurisdiction issues defined therein. Any holder of this document is advised that information contained hereon reflects the Company's findings at the time of its intervention only and within the limits of Client's instructions, if any. The Company's sole responsibility is to its Client and this document does not exonerate parties to a transaction from exercising all their rights and obligations under the transaction documents. This document cannot be reproduced except in full, without prior written approval of the Company. Any unauthorized alteration, forgery or falsification of the content or appearance of this document is unlawful and offenders may be prosecuted to the fullest extent of the law.

## 8 PEAK OUTPUT POWER MEASUREMENT

### 8.1 Standard Applicable

For frequency hopping systems operating in the 2400-2483.5 MHz band employing at least 75 hopping channels, The Limit: 1Watt. For all other frequency hopping systems in the 2400 – 2483.5MHz band: The Limit: 0.125 Watts. The power limit for 1Mbps is 1watt, and 2Mbps, 3Mbps and AFH mode are 0.125 watts.

### 8.2 Test Setup

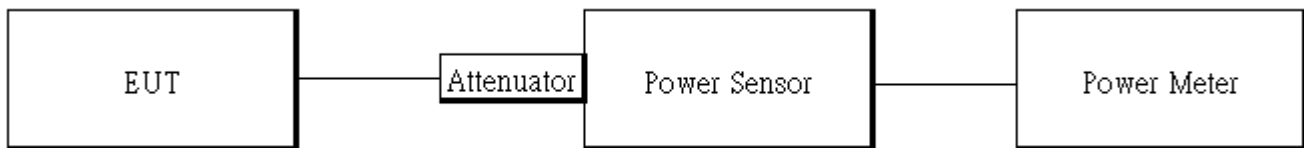

### 8.3 Measurement Procedure:

1. Place the EUT on the table and set it in transmitting mode.
2. The testing follows ANSI C63.10 Measurement Guidelines.
3. Duty cycle of test signal is < 98 %, duty factor shall be considered.
4. Remove the antenna from the EUT and then connect a low loss RF cable from the antenna port to the power meter or spectrum. (Max Hold, Detector = Peak, RBW >=20dB bandwidth)
5. Record the max. reading.
6. Repeat above procedures until all default test channel is completed.

Unless otherwise stated the results shown in this test report refer only to the sample(s) tested and such sample(s) are retained for 90 days only.  
 除非另有說明，此報告結果僅對測試之樣品負責，同時此樣品僅保留90天。本報告未經本公司書面許可，不可部份複製。

This document is issued by the Company subject to its General Conditions of Service printed overleaf, available on request or accessible at <http://www.sgs.com.tw/Terms-and-Conditions> and for electronic format documents, subject to Terms and Conditions for Electronic Documents at <http://www.sgs.com.tw/Terms-and-Conditions>. Attention is drawn to the limitation of liability, indemnification and jurisdiction issues defined therein. Any holder of this document is advised that information contained hereon reflects the Company's findings at the time of its intervention only and within the limits of Client's instructions, if any. The Company's sole responsibility is to its Client and this document does not exonerate parties to a transaction from exercising all their rights and obligations under the transaction documents. This document cannot be reproduced except in full, without prior written approval of the Company. Any unauthorized alteration, forgery or falsification of the content or appearance of this document is unlawful and offenders may be prosecuted to the fullest extent of the law.

### 8.4 Peak & Average Power Measurement Result

1M BR mode (Peak):

CH	Freq. (MHz)	Power set	Peak Output Power (dBm)	Output Power (mW)	Limit (mW)
Low	2402	6	<b>7.14</b>	5.176	1000
Mid	2441	6	7.10	5.129	1000
High	2480	6	7.04	5.058	1000

1M BR mode (Average):

CH	Freq. (MHz)	Power set	Avg. Output Power (dBm)	Output Power (mW)	Limit (mW)
Low	2402	6	7.00	5.016	1000
Mid	2441	6	6.95	4.959	1000
High	2480	6	6.94	4.947	1000

2M EDR mode (Peak):

CH	Freq. (MHz)	Power set	Peak Output Power (dBm)	Output Power (mW)	Limit (mW)
Low	2402	6	<b>9.78</b>	9.506	125
Mid	2441	6	9.76	9.462	125
High	2480	6	9.75	9.441	125

2M EDR mode (Average):

CH	Freq. (MHz)	Power set	Avg. Output Power (dBm)	Output Power (mW)	Limit (mW)
Low	2402	6	7.02	5.039	125
Mid	2441	6	7.01	5.028	125
High	2480	6	6.94	4.947	125

3M EDR mode (Peak):

CH	Freq. (MHz)	Power set	Peak Output Power (dBm)	Output Power (mW)	Limit (mW)
Low	2402	6	<b>10.31</b>	10.740	125
Mid	2441	6	10.30	10.715	125
High	2480	6	10.28	10.666	125

3M EDR mode (Average):

CH	Freq. (MHz)	Power set	Avg. Output Power (dBm)	Output Power (mW)	Limit (mW)
Low	2402	6	7.07	5.089	125
Mid	2441	6	7.03	5.042	125
High	2480	6	7.01	5.019	125

\*Note: Max. Output include tune up tolerance Power measured by using average detector.

Unless otherwise stated the results shown in this test report refer only to the sample(s) tested and such sample(s) are retained for 90 days only.

除非另有說明，此報告結果僅對測試之樣品負責，同時此樣品僅保留90天。本報告未經本公司書面許可，不可部份複製。

This document is issued by the Company subject to its General Conditions of Service printed overleaf, available on request or accessible at <http://www.sgs.com.tw/Terms-and-Conditions>, and for electronic format documents, subject to Terms and Conditions for Electronic Documents at <http://www.sgs.com.tw/Terms-and-Conditions>. Attention is drawn to the limitation of liability, indemnification and jurisdiction issues defined therein. Any holder of this document is advised that information contained hereon reflects the Company's findings at the time of its intervention only and within the limits of Client's instructions, if any. The Company's sole responsibility is to its Client and this document does not exonerate parties to a transaction from exercising all their rights and obligations under the transaction documents. This document cannot be reproduced except in full, without prior written approval of the Company. Any unauthorized alteration, forgery or falsification of the content or appearance of this document is unlawful and offenders may be prosecuted to the fullest extent of the law.

## 9 EMISSION BANDWIDTH MEASUREMENT

### 9.1 Standard Applicable

For frequency hopping systems operating in the 2400 MHz-2483.5 MHz no limit for 20dB bandwidth.

### 9.2 Test Setup

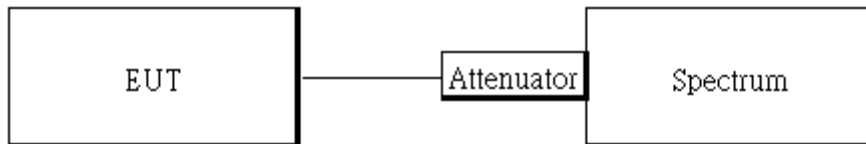

### 9.3 Measurement Procedure

1. Place the EUT on the table and set it in transmitting mode.
2. The testing follows ANSI C63.10:2013.
3. Remove the antenna from the EUT and then connect a low loss RF cable from the antenna port to the spectrum analyzer.
4. Set the spectrum analyzer as  
 RBW= 1 % to 5% of OBW ,  
 VBW = 3 X RBW,  
 Span= 2 to 5 times of the OBW,  
 Sweep=auto,  
 Detector = Peak, and Max hold for 20dB Bandwidth test.
5. Mark the peak frequency and -20dB (upper and lower) frequency
6. Repeat above procedures until all test default channel is completed

Unless otherwise stated the results shown in this test report refer only to the sample(s) tested and such sample(s) are retained for 90 days only.  
 除非另有說明，此報告結果僅對測試之樣品負責，同時此樣品僅保留90天。本報告未經本公司書面許可，不可部份複製。

This document is issued by the Company subject to its General Conditions of Service printed overleaf, available on request or accessible at <http://www.sgs.com.tw/Terms-and-Conditions> and for electronic format documents, subject to Terms and Conditions for Electronic Documents at <http://www.sgs.com.tw/Terms-and-Conditions>. Attention is drawn to the limitation of liability, indemnification and jurisdiction issues defined therein. Any holder of this document is advised that information contained hereon reflects the Company's findings at the time of its intervention only and within the limits of Client's instructions, if any. The Company's sole responsibility is to its Client and this document does not exonerate parties to a transaction from exercising all their rights and obligations under the transaction documents. This document cannot be reproduced except in full, without prior written approval of the Company. Any unauthorized alteration, forgery or falsification of the content or appearance of this document is unlawful and offenders may be prosecuted to the fullest extent of the law.



## 9.4 20dB Bandwidth

**GFSK**

CH	20 dB BW (MHz)	2/3 BW (MHz)
Low	0.9651	0.64
Mid	0.9639	0.64
High	0.9618	0.64

 **$\pi/4$ -DQPSK**

CH	20 dB BW (MHz)	2/3 BW (MHz)
Low	1.334	0.89
Mid	1.335	0.89
High	1.337	0.89

**8-DPSK**

CH	20 dB BW (MHz)	2/3 BW (MHz)
Low	1.314	0.88
Mid	1.316	0.88
High	1.313	0.88

Unless otherwise stated the results shown in this test report refer only to the sample(s) tested and such sample(s) are retained for 90 days only.  
 除非另有說明，此報告結果僅對測試之樣品負責，同時此樣品僅保留90天。本報告未經本公司書面許可，不可部份複製。

This document is issued by the Company subject to its General Conditions of Service printed overleaf, available on request or accessible at <http://www.sgs.com.tw/Terms-and-Conditions> and for electronic format documents, subject to Terms and Conditions for Electronic Documents at <http://www.sgs.com.tw/Terms-and-Conditions>. Attention is drawn to the limitation of liability, indemnification and jurisdiction issues defined therein. Any holder of this document is advised that information contained hereon reflects the Company's findings at the time of its intervention only and within the limits of Client's instructions, if any. The Company's sole responsibility is to its Client and this document does not exonerate parties to a transaction from exercising all their rights and obligations under the transaction documents. This document cannot be reproduced except in full, without prior written approval of the Company. Any unauthorized alteration, forgery or falsification of the content or appearance of this document is unlawful and offenders may be prosecuted to the fullest extent of the law.

OBW 20dB\_GFSK\_1M\_DH5\_2402MHz

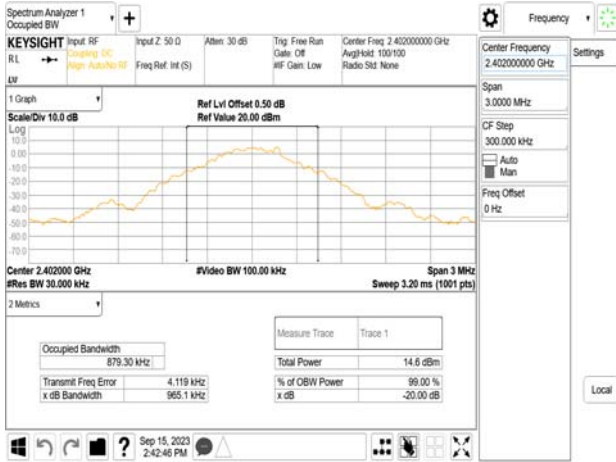

OBW 20dB\_π/4DQPSK\_2M\_DH5\_2402MHz



OBW 20dB\_GFSK\_1M\_DH5\_2441MHz

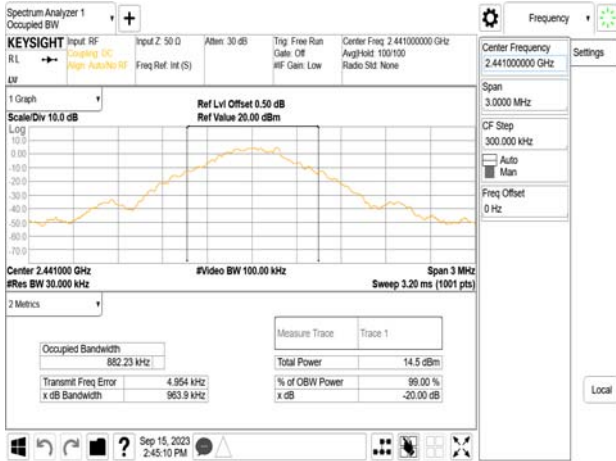

OBW 20dB\_π/4DQPSK\_2M\_DH5\_2441MHz

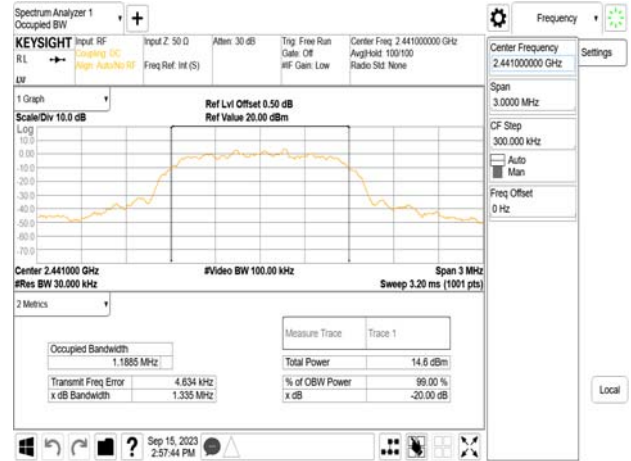

OBW 20dB\_GFSK\_1M\_DH5\_2480MHz

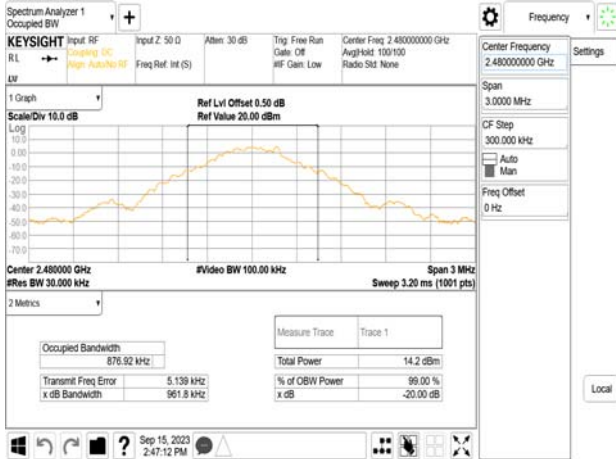

OBW 20dB\_π/4DQPSK\_2M\_DH5\_2480MHz



Unless otherwise stated the results shown in this test report refer only to the sample(s) tested and such sample(s) are retained for 90 days only.

除非另有說明，此報告結果僅對測試之樣品負責，同時此樣品僅保留90天。本報告未經本公司書面許可，不可部份複製。

This document is issued by the Company subject to its General Conditions of Service printed overleaf, available on request or accessible at <http://www.sgs.com.tw/Terms-and-Conditions> and for electronic format documents, subject to Terms and Conditions for Electronic Documents at <http://www.sgs.com.tw/Terms-and-Conditions>. Attention is drawn to the limitation of liability, indemnification and jurisdiction issues defined therein. Any holder of this document is advised that information contained hereon reflects the Company's findings at the time of its intervention only and within the limits of Client's instructions, if any. The Company's sole responsibility is to its Client and this document does not exonerate parties to a transaction from exercising all their rights and obligations under the transaction documents. This document cannot be reproduced except in full, without prior written approval of the Company. Any unauthorized alteration, forgery or falsification of the content or appearance of this document is unlawful and offenders may be prosecuted to the fullest extent of the law.

OBW 20dB\_8DPSK\_3M\_DH5\_2402MHz



OBW 20dB\_8DPSK\_3M\_DH5\_2441MHz

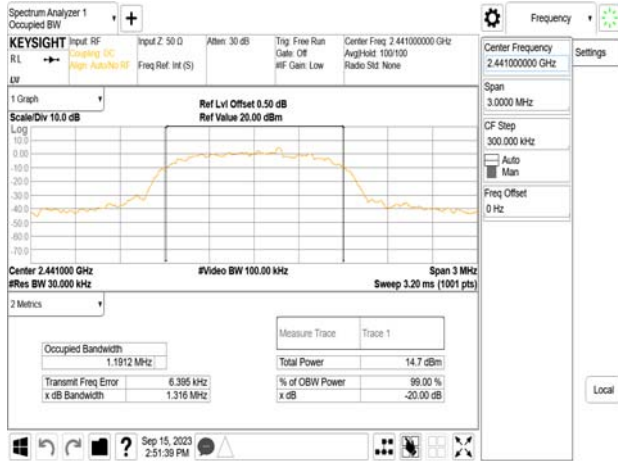

OBW 20dB\_8DPSK\_3M\_DH5\_2480MHz



Unless otherwise stated the results shown in this test report refer only to the sample(s) tested and such sample(s) are retained for 90 days only.

除非另有說明，此報告結果僅對測試之樣品負責，同時此樣品僅保留90天。本報告未經本公司書面許可，不可部份複製。

This document is issued by the Company subject to its General Conditions of Service printed overleaf, available on request or accessible at <http://www.sgs.com.tw/Terms-and-Conditions>, and for electronic format documents, subject to Terms and Conditions for Electronic Documents at <http://www.sgs.com.tw/Terms-and-Conditions>. Attention is drawn to the limitation of liability, indemnification and jurisdiction issues defined therein. Any holder of this document is advised that information contained hereon reflects the Company's findings at the time of its intervention only and within the limits of Client's instructions, if any. The Company's sole responsibility is to its Client and this document does not exonerate parties to a transaction from exercising all their rights and obligations under the transaction documents. This document cannot be reproduced except in full, without prior written approval of the Company. Any unauthorized alteration, forgery or falsification of the content or appearance of this document is unlawful and offenders may be prosecuted to the fullest extent of the law.

## 10 CONDUCTED BAND EDGES AND SPURIOUS EMISSION MEASUREMENT

### 10.1 Standard Applicable

In any 100 kHz bandwidth outside the frequency band in which the spread spectrum or digitally modulated intentional radiator is operating, the radio frequency power that is produced by the intentional radiator shall be at least 20 dB below that in the 100 kHz bandwidth within the band that contains the highest level of the desired power, based on either an RF conducted or a radiated measurement, provided the transmitter demonstrates compliance with the peak conducted power limits. In addition, radiated emissions which fall in the restricted bands, as defined in §15.205(a), must also comply with the radiated emission limits specified in §15.209(a).

### 10.2 Test Setup

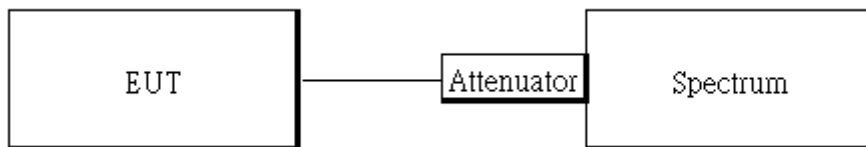

### 10.3 Measurement Procedure

#### 10.3.1 Conducted Band Edge:

1. Place the EUT on the table and set it in transmitting mode.
2. The testing follows ANSI C63.10:2013.
3. Remove the antenna from the EUT and then connect a low loss RF cable from the antenna port to the spectrum analyzer.
4. Set center frequency of spectrum analyzer = operating frequency.
5. Set the spectrum analyzer as RBW=100 kHz, VBW=300 kHz, Sweep = auto
6. Mark Peak, below 2.4GHz and above 2.4835GHz and record the max. level.
7. Repeat above procedures until all frequency measured were complete.

#### 10.3.2 Conducted Spurious Emission:

1. To connect Antenna Port of EUT to Spectrum.
2. The testing follows ANSI C63.10:2013.
3. Set RBW = 100 kHz & VBW = 300 kHz, Detector =Peak, Sweep = Auto
4. Allow trace to fully stabilize.
5. Use the peak marker function to determine the maximum power level in any 100 kHz band segment within the fundamental EBW.
6. Repeat above procedures until all default test channel measured were complete.

### 10.4 Measurement Result

See next page for test plots.

Unless otherwise stated the results shown in this test report refer only to the sample(s) tested and such sample(s) are retained for 90 days only.

除非另有說明，此報告結果僅對測試之樣品負責，同時此樣品僅保留90天。本報告未經本公司書面許可，不可部份複製。

This document is issued by the Company subject to its General Conditions of Service printed overleaf, available on request or accessible at <http://www.sgs.com.tw/Terms-and-Conditions>, and for electronic format documents, subject to Terms and Conditions for Electronic Documents at <http://www.sgs.com.tw/Terms-and-Conditions>. Attention is drawn to the limitation of liability, indemnification and jurisdiction issues defined therein. Any holder of this document is advised that information contained hereon reflects the Company's findings at the time of its intervention only and within the limits of Client's instructions, if any. The Company's sole responsibility is to its Client and this document does not exonerate parties to a transaction from exercising all their rights and obligations under the transaction documents. This document cannot be reproduced except in full, without prior written approval of the Company. Any unauthorized alteration, forgery or falsification of the content or appearance of this document is unlawful and offenders may be prosecuted to the fullest extent of the law.

Band Edge\_GFSK\_1M\_DH5\_2402MHz

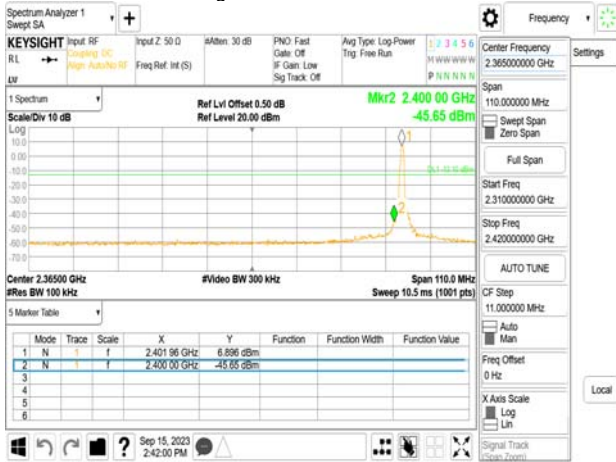

Band Edge\_8DPSK\_3M\_DH5\_2480MHz

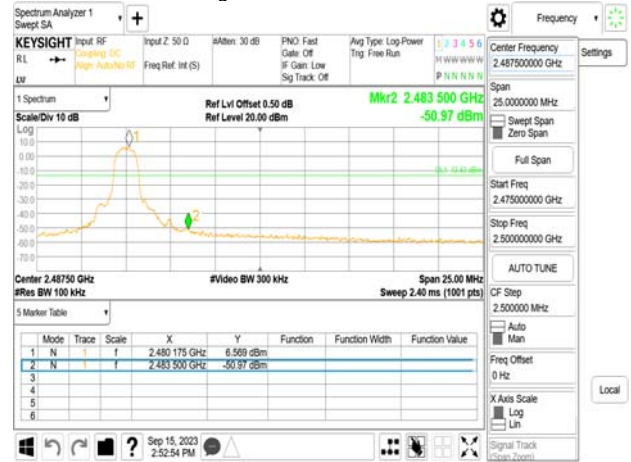

Band Edge\_GFSK\_1M\_DH5\_2480MHz

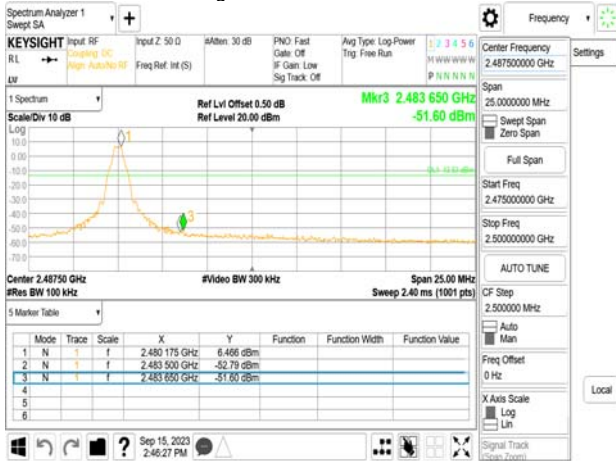

Hopping Band Edge\_GFSK\_1M\_DH5\_2402MHz



Band Edge\_8DPSK\_3M\_DH5\_2402MHz

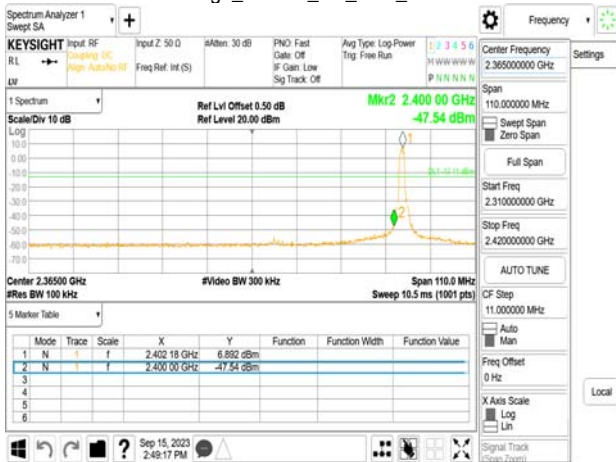

Hopping Band Edge\_GFSK\_1M\_DH5\_2480MHz

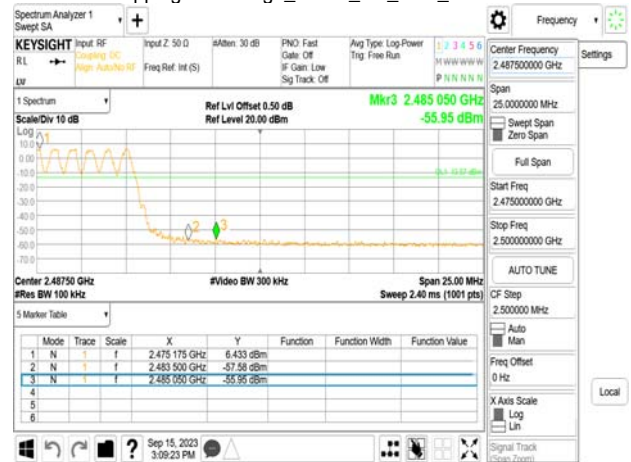

Unless otherwise stated the results shown in this test report refer only to the sample(s) tested and such sample(s) are retained for 90 days only.

除非另有說明，此報告結果僅對測試之樣品負責，同時此樣品僅保留90天。本報告未經本公司書面許可，不可部份複製。

This document is issued by the Company subject to its General Conditions of Service printed overleaf, available on request or accessible at <http://www.sgs.com.tw/Terms-and-Conditions> and for electronic format documents, subject to Terms and Conditions for Electronic Documents at <http://www.sgs.com.tw/Terms-and-Conditions>. Attention is drawn to the limitation of liability, indemnification and jurisdiction issues defined therein. Any holder of this document is advised that information contained hereon reflects the Company's findings at the time of its intervention only and within the limits of Client's instructions, if any. The Company's sole responsibility is to its Client and this document does not exonerate parties to a transaction from exercising all their rights and obligations under the transaction documents. This document cannot be reproduced except in full, without prior written approval of the Company. Any unauthorized alteration, forgery or falsification of the content or appearance of this document is unlawful and offenders may be prosecuted to the fullest extent of the law.

Hopping Band Edge\_8DPSK\_3M\_DH5\_2402MHz



Spurious Emission\_GFSK\_1M\_DH5\_2441MHz



Hopping Band Edge\_8DPSK\_3M\_DH5\_2480MHz

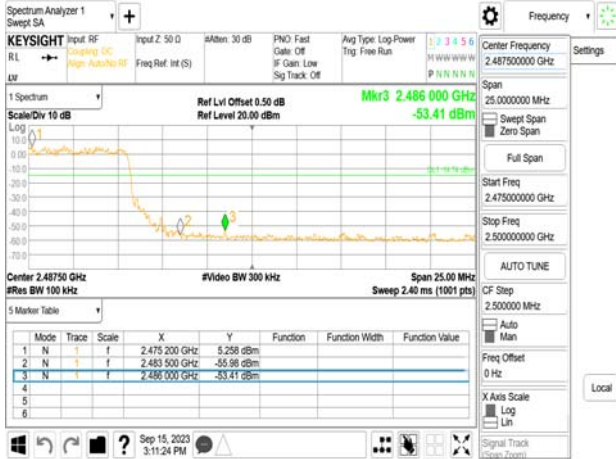

Spurious Emission\_GFSK\_1M\_DH5\_2480MHz



Spurious Emission\_GFSK\_1M\_DH5\_2402MHz



Spurious Emission\_π/4DQPSK\_2M\_DH5\_2402MHz



Unless otherwise stated the results shown in this test report refer only to the sample(s) tested and such sample(s) are retained for 90 days only.

除非另有說明，此報告結果僅對測試之樣品負責，同時此樣品僅保留90天。本報告未經本公司書面許可，不可部份複製。

This document is issued by the Company subject to its General Conditions of Service printed overleaf, available on request or accessible at <http://www.sgs.com.tw/Terms-and-Conditions> and for electronic format documents, subject to Terms and Conditions for Electronic Documents at <http://www.sgs.com.tw/Terms-and-Conditions>. Attention is drawn to the limitation of liability, indemnification and jurisdiction issues defined therein. Any holder of this document is advised that information contained hereon reflects the Company's findings at the time of its intervention only and within the limits of Client's instructions, if any. The Company's sole responsibility is to its Client and this document does not exonerate parties to a transaction from exercising all their rights and obligations under the transaction documents. This document cannot be reproduced except in full, without prior written approval of the Company. Any unauthorized alteration, forgery or falsification of the content or appearance of this document is unlawful and offenders may be prosecuted to the fullest extent of the law.

Spurious Emission\_π/4DQPSK\_2M\_DH5\_2441MHz



Spurious Emission\_8DPSK\_3M\_DH5\_2441MHz



Spurious Emission\_π/4DQPSK\_2M\_DH5\_2480MHz



Spurious Emission\_8DPSK\_3M\_DH5\_2480MHz



Spurious Emission\_8DPSK\_3M\_DH5\_2402MHz



Unless otherwise stated the results shown in this test report refer only to the sample(s) tested and such sample(s) are retained for 90 days only.

除非另有說明，此報告結果僅對測試之樣品負責，同時此樣品僅保留90天。本報告未經本公司書面許可，不可部份複製。

This document is issued by the Company subject to its General Conditions of Service printed overleaf, available on request or accessible at <http://www.sgs.com.tw/Terms-and-Conditions>, and for electronic format documents, subject to Terms and Conditions for Electronic Documents at <http://www.sgs.com.tw/Terms-and-Conditions>. Attention is drawn to the limitation of liability, indemnification and jurisdiction issues defined therein. Any holder of this document is advised that information contained hereon reflects the Company's findings at the time of its intervention only and within the limits of Client's instructions, if any. The Company's sole responsibility is to its Client and this document does not exonerate parties to a transaction from exercising all their rights and obligations under the transaction documents. This document cannot be reproduced except in full, without prior written approval of the Company. Any unauthorized alteration, forgery or falsification of the content or appearance of this document is unlawful and offenders may be prosecuted to the fullest extent of the law.

## 11 RADIATED BANDEDGE AND SPURIOUS EMISSION MEASUREMENT

### 11.1 Standard Applicable

#### 11.1.1 Duty Cycle Correction Factor

According to 15.35(c), the measurement field strength shall be determined by averaging over one complete pulse train, including blanking intervals, as long as the pulse train does not exceed 0.1 seconds. As an alternative (provided the transmitter operates for longer than 0.1 seconds) or in cases where the pulse train exceeds 0.1 seconds, the measured field strength shall be determined from the average absolute voltage during a 0.1 second interval during which the field strength is at its maximum value. The exact method of calculating the average field strength shall be submitted with any application for certification.

#### 11.1.2 Spurious Emission

In any 100 kHz bandwidth outside the frequency band in which the spread spectrum or digitally modulated intentional radiator is operating, the radio frequency power that is produced by the intentional radiator shall be at least 20 dB below that in the 100 kHz bandwidth within the band that contains the highest level of the desired power, based on either an RF conducted or a radiated measurement, provided the transmitter demonstrates compliance with the peak conducted power limits. In addition, radiated emissions which fall in the restricted bands must also comply with the §15.209 limit as below.

And according to §15.33(a) (1), for an intentional radiator operates below 10GHz, the frequency range of measurements: to the tenth harmonic of the highest fundamental frequency or to 40GHz, whichever is lower.

Frequency (MHz)	Field strength (microvolts/meter)	Distance (meters)
0.009-0.490	2400/F(kHz)	300
0.490-1.705	24000/F(kHz)	30
1.705-30	30	30
30-88	100	3
88-216	150	3
216-960	200	3
Above 960	500	3

**Note:**

1. The lower limit shall apply at the transition frequencies.

Unless otherwise stated the results shown in this test report refer only to the sample(s) tested and such sample(s) are retained for 90 days only.

除非另有說明，此報告結果僅對測試之樣品負責，同時此樣品僅保留90天。本報告未經本公司書面許可，不可部份複製。

This document is issued by the Company subject to its General Conditions of Service printed overleaf, available on request or accessible at <http://www.sgs.com.tw/Terms-and-Conditions>, and for electronic format documents, subject to Terms and Conditions for Electronic Documents at <http://www.sgs.com.tw/Terms-and-Conditions>. Attention is drawn to the limitation of liability, indemnification and jurisdiction issues defined therein. Any holder of this document is advised that information contained hereon reflects the Company's findings at the time of its intervention only and within the limits of Client's instructions, if any. The Company's sole responsibility is to its Client and this document does not exonerate parties to a transaction from exercising all their rights and obligations under the transaction documents. This document cannot be reproduced except in full, without prior written approval of the Company. Any unauthorized alteration, forgery or falsification of the content or appearance of this document is unlawful and offenders may be prosecuted to the fullest extent of the law.



## 11.2 Test Setup

### 11.2.1 Duty Cycle Correction Factor

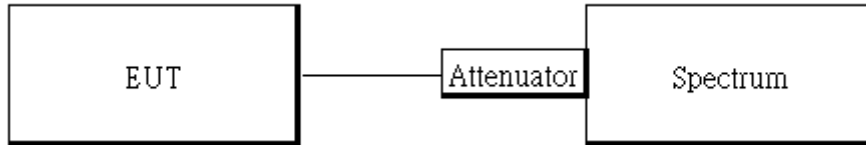

### 11.2.2 Radiated Emission

#### (A) Radiated Emission Test Set-Up, Frequency Below 30MHz.

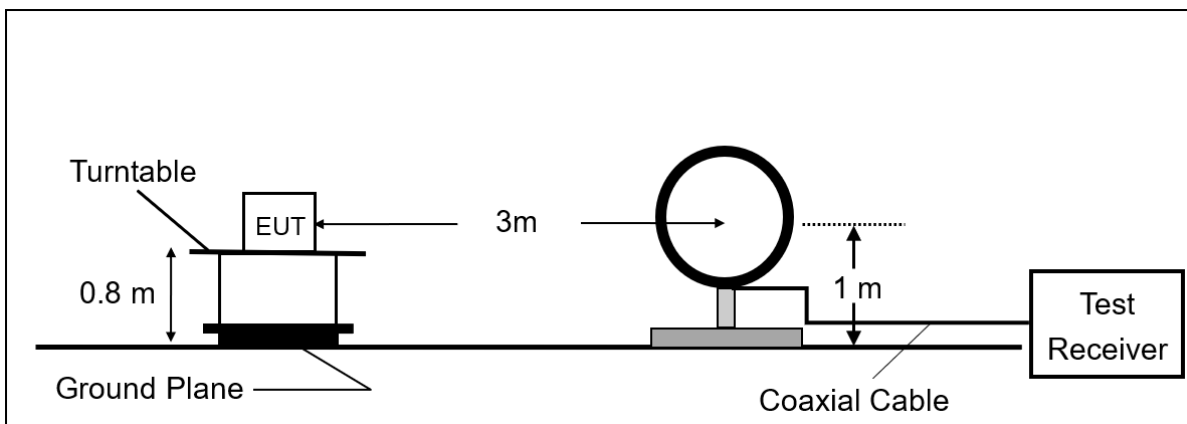

#### (B) Radiated Emission Test Set-Up, Frequency From 30MHz to 1000MHz.

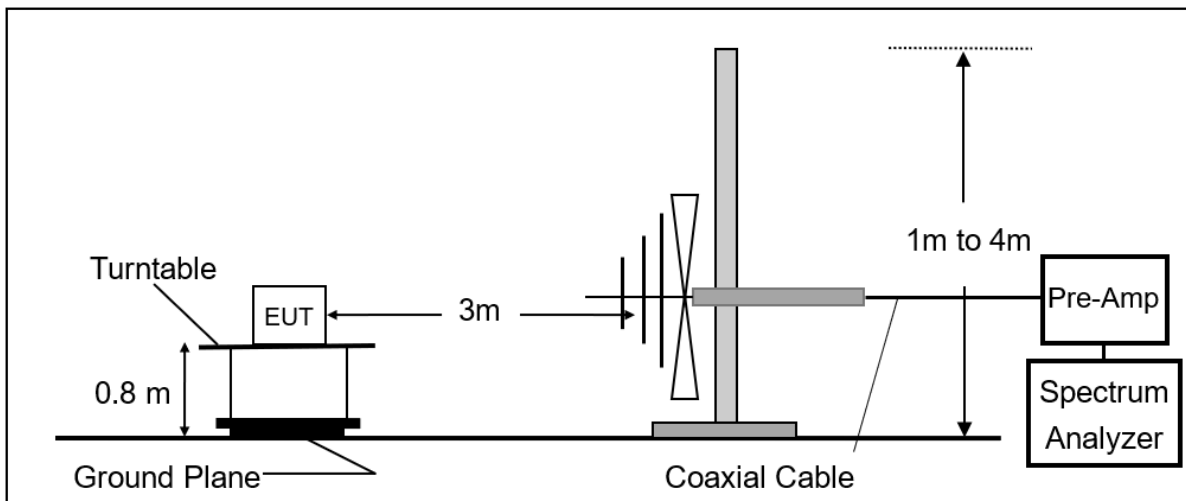

Unless otherwise stated the results shown in this test report refer only to the sample(s) tested and such sample(s) are retained for 90 days only.

除非另有說明，此報告結果僅對測試之樣品負責，同時此樣品僅保留90天。本報告未經本公司書面許可，不可部份複製。

This document is issued by the Company subject to its General Conditions of Service printed overleaf, available on request or accessible at <http://www.sgs.com.tw/Terms-and-Conditions> and for electronic format documents, subject to Terms and Conditions for Electronic Documents at <http://www.sgs.com.tw/Terms-and-Conditions>. Attention is drawn to the limitation of liability, indemnification and jurisdiction issues defined therein. Any holder of this document is advised that information contained hereon reflects the Company's findings at the time of its intervention only and within the limits of Client's instructions, if any. The Company's sole responsibility is to its Client and this document does not exonerate parties to a transaction from exercising all their rights and obligations under the transaction documents. This document cannot be reproduced except in full, without prior written approval of the Company. Any unauthorized alteration, forgery or falsification of the content or appearance of this document is unlawful and offenders may be prosecuted to the fullest extent of the law.

(C) Radiated Emission Test Set-Up, Frequency Above 1 GHz.

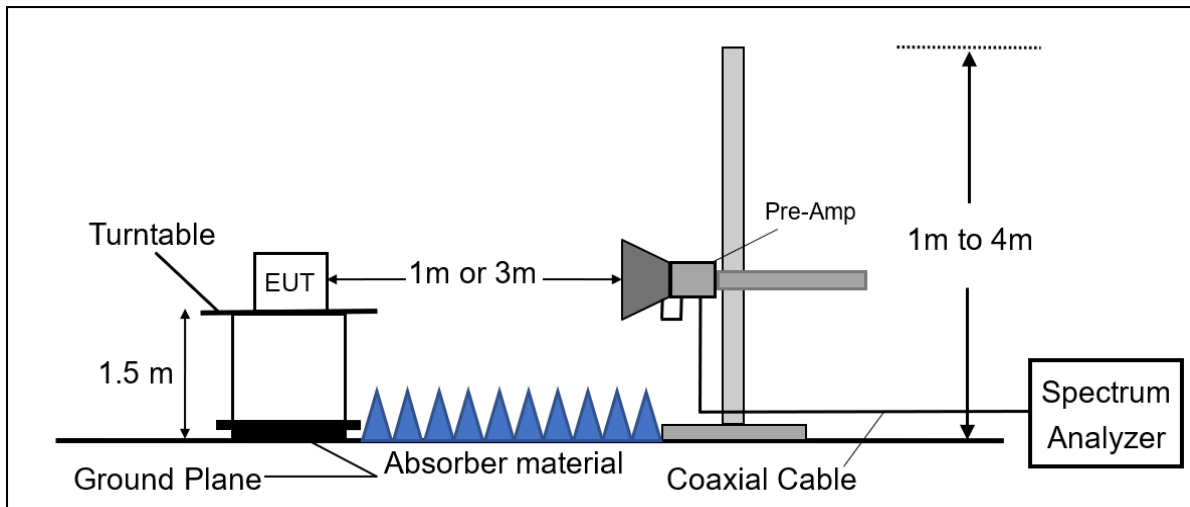

### 11.3 Measurement Procedure

#### 11.3.1 Duty Cycle Correction Factor

1. Adjust and configure any EUT switches, controls, or input data streams to ensure that the EUT is transmitting or encoded to obtain the “worst-case” pulse ON time.
2. The testing follows ANSI C63.10:2013.
3. Remove the antenna from the EUT and then connect a low loss RF cable from the antenna port to the spectrum analyzer.
4. Set center frequency of spectrum analyzer = operating frequency.
5. Set the spectrum analyzer as RBW, VBW=1MHz, 3MHz, Span = 0Hz , Detector = Peak, Adjust Sweep=100ms.
6. Repeat above procedures until all frequency of the interest measured were complete.

#### 11.3.2 Radiated Emission

1. The testing follows the Measurement Procedure of ANSI C63.10:2013.
2. The EUT was placed on a turn table with 0.8m for frequency < 1GHz and 1.5m for frequency > 1GHz above ground plane.
3. The turn table shall rotate 360 degrees to determine the position of maximum emission level.
4. EUT is set 3m away from the receiving antenna which varied from 1m to 4m to find out the highest emissions.
5. Set the spectrum analyzer as RBW=100 kHz and VBW=300 kHz for Peak Detector (PK) at frequency between 30MHz and 1 GHz.
6. Use receiver mode as RBW=120 kHz for Quasi-peak (QP) at frequency between 30MHz and 1 GHz.

Unless otherwise stated the results shown in this test report refer only to the sample(s) tested and such sample(s) are retained for 90 days only.  
 除非另有說明，此報告結果僅對測試之樣品負責，同時此樣品僅保留90天。本報告未經本公司書面許可，不可部份複製。

This document is issued by the Company subject to its General Conditions of Service printed overleaf, available on request or accessible at <http://www.sgs.com.tw/Terms-and-Conditions> and for electronic format documents, subject to Terms and Conditions for Electronic Documents at <http://www.sgs.com.tw/Terms-and-Conditions>. Attention is drawn to the limitation of liability, indemnification and jurisdiction issues defined therein. Any holder of this document is advised that information contained herein reflects the Company's findings at the time of its intervention only and within the limits of Client's instructions, if any. The Company's sole responsibility is to its Client and this document does not exonerate parties to a transaction from exercising all their rights and obligations under the transaction documents. This document cannot be reproduced except in full, without prior written approval of the Company. Any unauthorized alteration, forgery or falsification of the content or appearance of this document is unlawful and offenders may be prosecuted to the fullest extent of the law.

7. Set the spectrum analyzer as RBW=1 MHz, VBW=3 MHz for Maximum Emission Measurements at frequency above 1 GHz.
8. According to C63.10:2013 Section 7.5 Procedure for determining the average value of pulsed emissions with duty cycle correction factor  $20 \log (T_{on}/100ms)$ .
9. When measurement procedures for electric field radiated emissions above 1 GHz the EUT measurement is to be made "while keeping the antenna in the 'cone of radiation' from that area and pointed at the area both in azimuth and elevation, with polarization oriented for maximum response." is still within the 3dB illumination BW of the measurement antenna.
10. Maximum procedure was performed on the six highest emissions to ensure EUT compliance.
11. And also, each emission was to be maximized by changing the polarization of receiving antenna both horizontal and vertical.
12. Repeat above procedures until all default test channel measured were complete.

#### 11.4 Field Strength Calculation

The field strength is calculated by adding the Antenna Factor and Cable Factor and subtracting the Amplifier Gain and Duty Cycle Correction Factor (if any) from the measured reading. The basic equation with a sample calculation is as follows:

$$FS = RA + AF + CL - AG$$

**Where** *FS = Field Strength*

*CL = Cable Attenuation Factor (Cable Loss)*

*RA = Reading Amplitude*

*AG = Amplifier Gain*

*AF = Antenna Factor*

*The limit of the emission level is expressed in dBuV/m, which converts  $20 \cdot \log(uV/m)$*

Actual FS(dBμV/m) = SPA. Reading level(dBμV) + Factor(dB)

Factor(dB) = Antenna Factor(dBμV/m) + Cable Loss(dB) – Pre\_Amplifier Gain(dB)

Average value(dBμV/m)=Peak Actual FS(dBμV/m)+ Duty Cycle Correction Factor(dB)

Duty Cycle Correction Factor(dB) =  $20 \log (T_{on}/100 \text{ ms})$

#### 11.5 Test Results of Radiated Spurious Emissions form 9 kHz to 30 MHz

The low frequency, which started from 9 kHz to 30MHz, was pre-scanned and the result which was 20dB lower than the limit per 15.31(o) was not reported.

Unless otherwise stated the results shown in this test report refer only to the sample(s) tested and such sample(s) are retained for 90 days only.

除非另有說明，此報告結果僅對測試之樣品負責，同時此樣品僅保留90天。本報告未經本公司書面許可，不可部份複製。

This document is issued by the Company subject to its General Conditions of Service printed overleaf, available on request or accessible at <http://www.sgs.com.tw/Terms-and-Conditions> and for electronic format documents, subject to Terms and Conditions for Electronic Documents at <http://www.sgs.com.tw/Terms-and-Conditions>. Attention is drawn to the limitation of liability, indemnification and jurisdiction issues defined therein. Any holder of this document is advised that information contained hereon reflects the Company's findings at the time of its intervention only and within the limits of Client's instructions, if any. The Company's sole responsibility is to its Client and this document does not exonerate parties to a transaction from exercising all their rights and obligations under the transaction documents. This document cannot be reproduced except in full, without prior written approval of the Company. Any unauthorized alteration, forgery or falsification of the content or appearance of this document is unlawful and offenders may be prosecuted to the fullest extent of the law.

## 11.6 Measurement Result:

### 11.6.1 Duty Cycle Correction Factor

1<sup>st</sup>

Bluetooth 1M			
Time ON of 100ms:	5.666	ms	
Duty Cycle=5.666ms / 100ms	0.05666	%	
Duty Cycle correction factor=20 LOG 0.05666	-24.93	dB	
Bluetooth 3M			
Time ON of 100ms:	5.334	ms	
Duty Cycle=5.334ms / 100ms	0.05334	%	
Duty Cycle correction factor=20 LOG 0.05334	-25.46	dB	

2<sup>nd</sup>

Bluetooth 1M			
Time ON of 100ms:	5.800	ms	
Duty Cycle=5.8ms / 100ms	0.058	%	
Duty Cycle correction factor=20 LOG 0.058	-24.73	dB	
Bluetooth 3M			
Time ON of 100ms:	5.600	ms	
Duty Cycle=5.6ms / 100ms	0.056	%	
Duty Cycle correction factor=20 LOG 0.056	-25.04	dB	

Unless otherwise stated the results shown in this test report refer only to the sample(s) tested and such sample(s) are retained for 90 days only.  
 除非另有說明，此報告結果僅對測試之樣品負責，同時此樣品僅保留90天。本報告未經本公司書面許可，不可部份複製。

This document is issued by the Company subject to its General Conditions of Service printed overleaf, available on request or accessible at <http://www.sgs.com.tw/Terms-and-Conditions> and for electronic format documents, subject to Terms and Conditions for Electronic Documents at <http://www.sgs.com.tw/Terms-and-Conditions>. Attention is drawn to the limitation of liability, indemnification and jurisdiction issues defined therein. Any holder of this document is advised that information contained herein reflects the Company's findings at the time of its intervention only and within the limits of Client's instructions, if any. The Company's sole responsibility is to its Client and this document does not exonerate parties to a transaction from exercising all their rights and obligations under the transaction documents. This document cannot be reproduced except in full, without prior written approval of the Company. Any unauthorized alteration, forgery or falsification of the content or appearance of this document is unlawful and offenders may be prosecuted to the fullest extent of the law.

### 11.6.2 Duty Cycle test plot

1st

BR

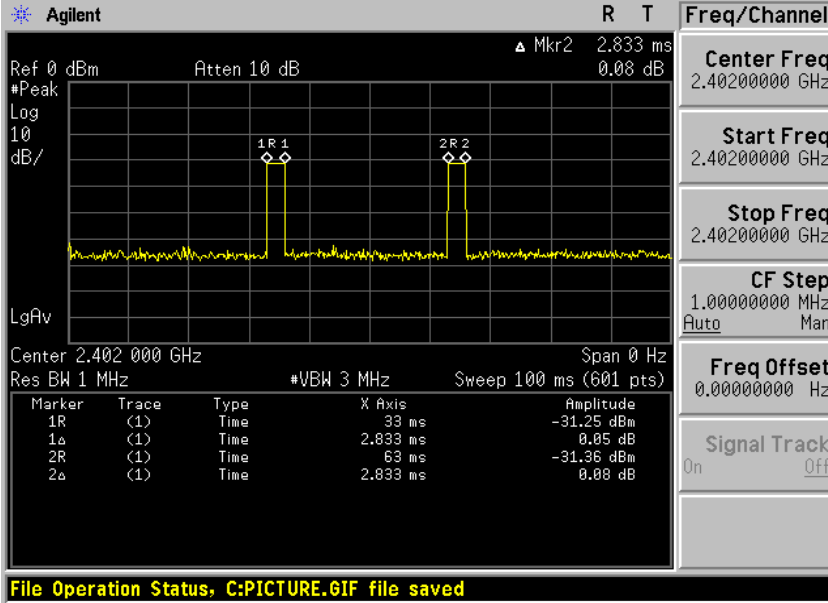

EDR

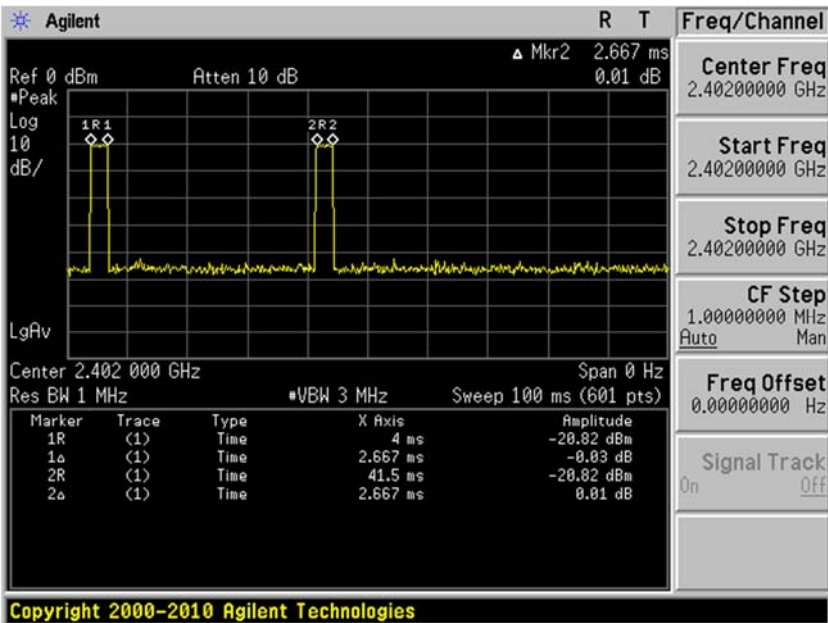

Unless otherwise stated the results shown in this test report refer only to the sample(s) tested and such sample(s) are retained for 90 days only.

除非另有說明，此報告結果僅對測試之樣品負責，同時此樣品僅保留90天。本報告未經本公司書面許可，不可部份複製。

This document is issued by the Company subject to its General Conditions of Service printed overleaf, available on request or accessible at <http://www.sgs.com.tw/Terms-and-Conditions> and for electronic format documents, subject to Terms and Conditions for Electronic Documents at <http://www.sgs.com.tw/Terms-and-Conditions>. Attention is drawn to the limitation of liability, indemnification and jurisdiction issues defined therein. Any holder of this document is advised that information contained hereon reflects the Company's findings at the time of its intervention only and within the limits of Client's instructions, if any. The Company's sole responsibility is to its Client and this document does not exonerate parties to a transaction from exercising all their rights and obligations under the transaction documents. This document cannot be reproduced except in full, without prior written approval of the Company. Any unauthorized alteration, forgery or falsification of the content or appearance of this document is unlawful and offenders may be prosecuted to the fullest extent of the law.

2<sup>nd</sup>

BR



EDR



Unless otherwise stated the results shown in this test report refer only to the sample(s) tested and such sample(s) are retained for 90 days only.

除非另有說明，此報告結果僅對測試之樣品負責，同時此樣品僅保留90天。本報告未經本公司書面許可，不可部份複製。

This document is issued by the Company subject to its General Conditions of Service printed overleaf, available on request or accessible at <http://www.sgs.com.tw/Terms-and-Conditions>, and for electronic format documents, subject to Terms and Conditions for Electronic Documents at <http://www.sgs.com.tw/Terms-and-Conditions>. Attention is drawn to the limitation of liability, indemnification and jurisdiction issues defined therein. Any holder of this document is advised that information contained hereon reflects the Company's findings at the time of its intervention only and within the limits of Client's instructions, if any. The Company's sole responsibility is to its Client and this document does not exonerate parties to a transaction from exercising all their rights and obligations under the transaction documents. This document cannot be reproduced except in full, without prior written approval of the Company. Any unauthorized alteration, forgery or falsification of the content or appearance of this document is unlawful and offenders may be prosecuted to the fullest extent of the law.

### 11.6.3 Bandedge Result

Report Number	:TERF2309002194ER	Test Site	:SAC 1
Operation Mode	:BR	Test Date	:2023-09-19
Test Frequency	:2402 MHz	Temp./Humi.	:24.0°C/62%
Test Mode	:Bandedge	Antenna Pol.	:Vertical
EUT Pol	:E2 Plane	Engineer	:Cooper Hsu

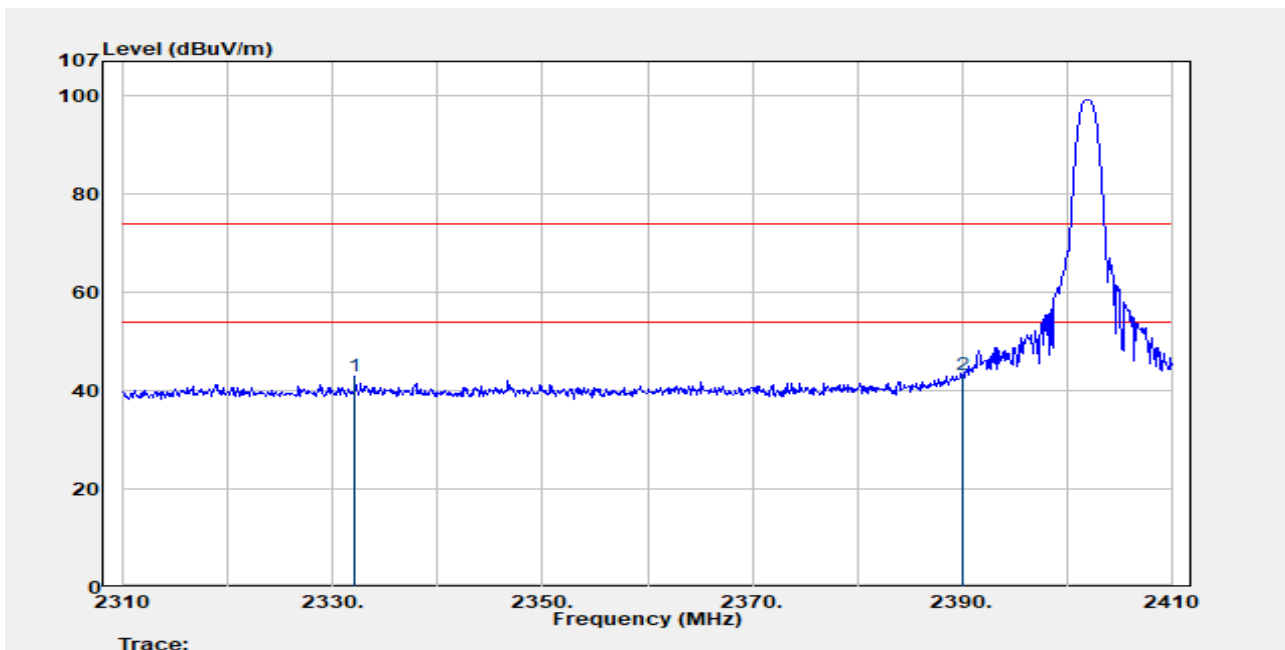

Freq. MHz	Detector Mode PK/QP/AV	Spectrum Reading Level dBμV	Factor dB	Actual FS dBμV/m	Limit @3m dBμV/m	Margin dB
2332.10	Peak	46.02	-3.18	42.83	74.00	-31.17
2390.00	Peak	46.71	-3.42	43.29	74.00	-30.71

Freq. MHz	Detector Mode AV	Peak Actual FS (dBμV/m)	Duty Cycle Factor (dB)	Average Value (dBuV/m)	Average Limit@3m (dBuV/m)	Margin (dB)
2332.100	Average	42.83	-24.93	17.90	54.00	-36.10
2390.000	Average	43.29	-24.93	18.36	54.00	-35.64

Unless otherwise stated the results shown in this test report refer only to the sample(s) tested and such sample(s) are retained for 90 days only.

除非另有說明，此報告結果僅對測試之樣品負責，同時此樣品僅保留90天。本報告未經本公司書面許可，不可部份複製。

This document is issued by the Company subject to its General Conditions of Service printed overleaf, available on request or accessible at <http://www.sgs.com.tw/Terms-and-Conditions> and for electronic format documents, subject to Terms and Conditions for Electronic Documents at <http://www.sgs.com.tw/Terms-and-Conditions>. Attention is drawn to the limitation of liability, indemnification and jurisdiction issues defined therein. Any holder of this document is advised that information contained hereon reflects the Company's findings at the time of its intervention only and within the limits of Client's instructions, if any. The Company's sole responsibility is to its Client and this document does not exonerate parties to a transaction from exercising all their rights and obligations under the transaction documents. This document cannot be reproduced except in full, without prior written approval of the Company. Any unauthorized alteration, forgery or falsification of the content or appearance of this document is unlawful and offenders may be prosecuted to the fullest extent of the law.

Report Number :TERF2309002194ER  
 Operation Mode :BR  
 Test Frequency :2402 MHz  
 Test Mode :Bandedge  
 EUT Pol :E2 Plane

Test Site :SAC 1  
 Test Date :2023-09-19  
 Temp./Humi. :24.0°C/62%  
 Antenna Pol. :Horizontal  
 Engineer :Cooper Hsu

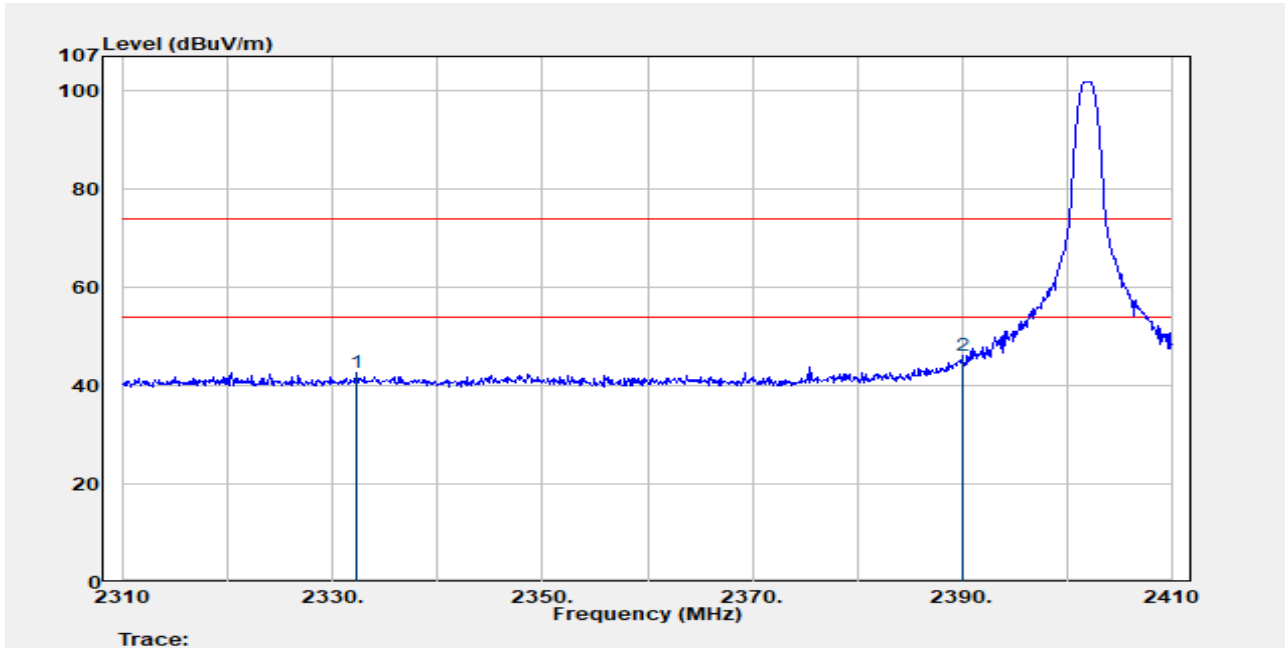

Freq. MHz	Detector Mode PK/QP/AV	Spectrum Reading Level d $\mu$ V	Factor dB	Actual FS d $\mu$ V/m	Limit @3m d $\mu$ V/m	Margin dB
2332.20	Peak	45.74	-3.18	42.56	74.00	-31.44
2390.00	Peak	49.53	-3.42	46.11	74.00	-27.89

Freq. MHz	Detector Mode AV	Peak Actual FS (d $\mu$ V/m)	Duty Cycle Factor (dB)	Average Value (d $\mu$ V/m)	Average Limit@3m (d $\mu$ V/m)	Margin (dB)
2332.200	Average	42.56	-24.93	17.63	54.00	-36.37
2390.000	Average	46.11	-24.93	21.18	54.00	-32.82

Unless otherwise stated the results shown in this test report refer only to the sample(s) tested and such sample(s) are retained for 90 days only.

除非另有說明，此報告結果僅對測試之樣品負責，同時此樣品僅保留90天。本報告未經本公司書面許可，不可部份複製。

This document is issued by the Company subject to its General Conditions of Service printed overleaf, available on request or accessible at <http://www.sgs.com.tw/Terms-and-Conditions> and for electronic format documents, subject to Terms and Conditions for Electronic Documents at <http://www.sgs.com.tw/Terms-and-Conditions>. Attention is drawn to the limitation of liability, indemnification and jurisdiction issues defined therein. Any holder of this document is advised that information contained hereon reflects the Company's findings at the time of its intervention only and within the limits of Client's instructions, if any. The Company's sole responsibility is to its Client and this document does not exonerate parties to a transaction from exercising all their rights and obligations under the transaction documents. This document cannot be reproduced except in full, without prior written approval of the Company. Any unauthorized alteration, forgery or falsification of the content or appearance of this document is unlawful and offenders may be prosecuted to the fullest extent of the law.



Report Number :TERF2309002194ER  
 Operation Mode :BR  
 Test Frequency :2480 MHz  
 Test Mode :Bandedge  
 EUT Pol :E2 Plane

Test Site :SAC 1  
 Test Date :2023-09-19  
 Temp./Humi. :24.0°C/62%  
 Antenna Pol. :Vertical  
 Engineer :Cooper Hsu

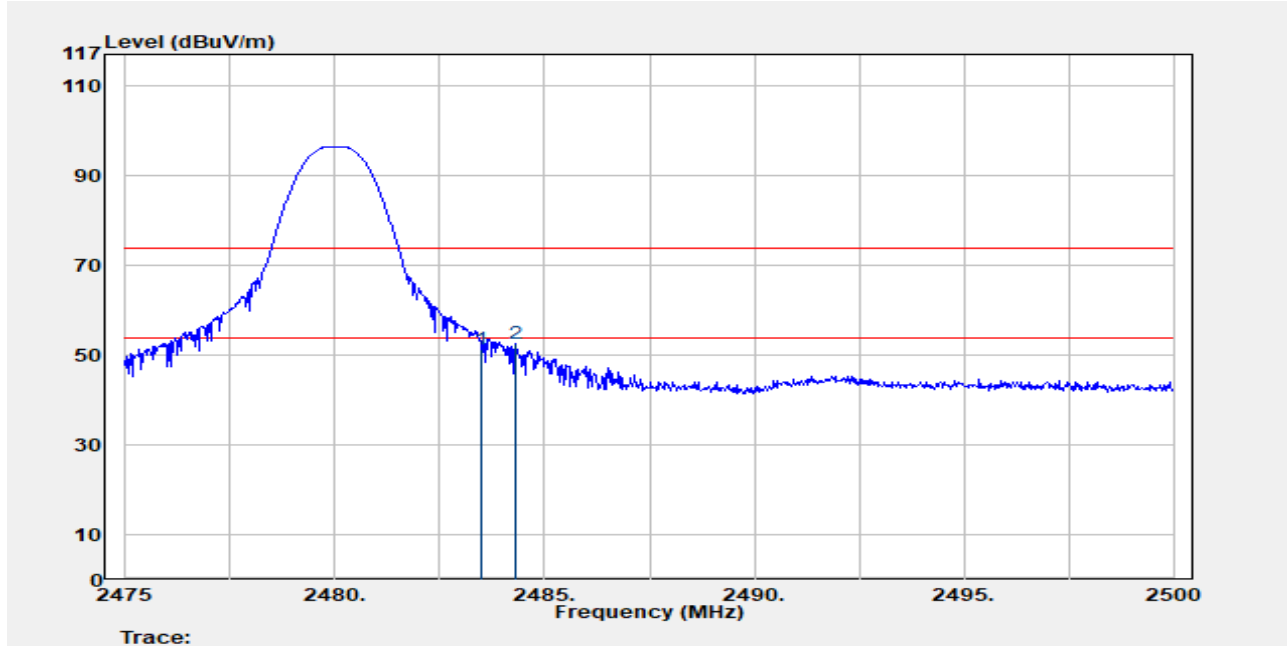

Freq. MHz	Detector Mode PK/QP/AV	Spectrum Reading Level dBUV	Factor dB	Actual FS dBUV/m	Limit @3m dBUV/m	Margin dB
2483.50	Peak	54.88	-3.45	51.44	74.00	-22.56
2484.33	Peak	55.94	-3.44	52.49	74.00	-21.51

Freq. MHz	Detector Mode AV	Peak Actual FS (dBUV/m)	Duty Cycle Factor (dB)	Average Value (dBUV/m)	Average Limit@3m (dBUV/m)	Margin (dB)
2483.500	Average	51.44	-24.93	26.51	54.00	-27.49
2484.330	Average	52.49	-24.93	27.56	54.00	-26.44

Unless otherwise stated the results shown in this test report refer only to the sample(s) tested and such sample(s) are retained for 90 days only.

除非另有說明，此報告結果僅對測試之樣品負責，同時此樣品僅保留90天。本報告未經本公司書面許可，不可部份複製。

This document is issued by the Company subject to its General Conditions of Service printed overleaf, available on request or accessible at <http://www.sgs.com.tw/Terms-and-Conditions>, and for electronic format documents, subject to Terms and Conditions for Electronic Documents at <http://www.sgs.com.tw/Terms-and-Conditions>. Attention is drawn to the limitation of liability, indemnification and jurisdiction issues defined therein. Any holder of this document is advised that information contained herein reflects the Company's findings at the time of its intervention only and within the limits of Client's instructions, if any. The Company's sole responsibility is to its Client and this document does not exonerate parties to a transaction from exercising all their rights and obligations under the transaction documents. This document cannot be reproduced except in full, without prior written approval of the Company. Any unauthorized alteration, forgery or falsification of the content or appearance of this document is unlawful and offenders may be prosecuted to the fullest extent of the law.

Report Number :TERF2309002194ER  
 Operation Mode :BR  
 Test Frequency :2480 MHz  
 Test Mode :Bandedge  
 EUT Pol :E2 Plane

Test Site :SAC 1  
 Test Date :2023-09-19  
 Temp./Humi. :24.0°C/62%  
 Antenna Pol. :Horizontal  
 Engineer :Cooper Hsu

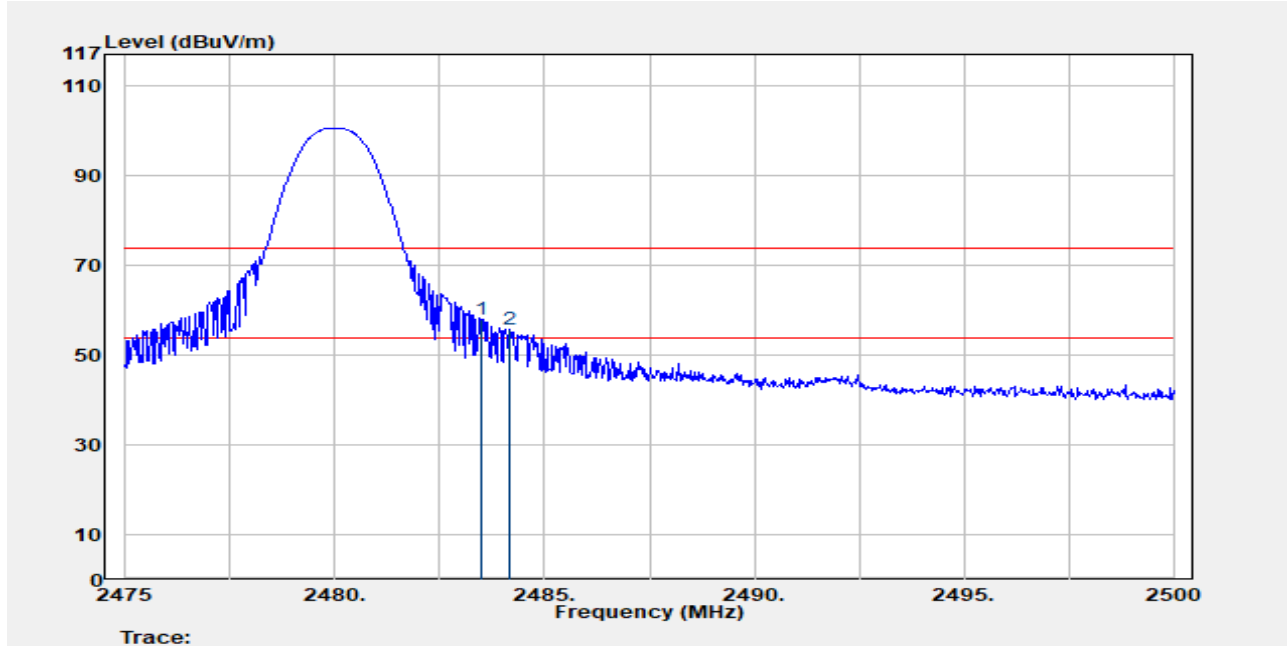

Freq. MHz	Detector Mode PK/QP/AV	Spectrum Reading Level dB $\mu$ V	Factor dB	Actual FS dB $\mu$ V/m	Limit @3m dB $\mu$ V/m	Margin dB
2483.50	Peak	61.61	-3.45	58.17	74.00	-15.83
2484.15	Peak	59.38	-3.44	55.94	74.00	-18.06

Freq. MHz	Detector Mode AV	Peak Actual FS (dB $\mu$ V/m)	Duty Cycle Factor (dB)	Average Value (dB $\mu$ V/m)	Average Limit@3m (dB $\mu$ V/m)	Margin (dB)
2483.500	Average	58.17	-24.93	33.24	54.00	-20.76
2484.150	Average	55.94	-24.93	31.01	54.00	-22.99

Unless otherwise stated the results shown in this test report refer only to the sample(s) tested and such sample(s) are retained for 90 days only.

除非另有說明，此報告結果僅對測試之樣品負責，同時此樣品僅保留90天。本報告未經本公司書面許可，不可部份複製。

This document is issued by the Company subject to its General Conditions of Service printed overleaf, available on request or accessible at <http://www.sgs.com.tw/Terms-and-Conditions>, and for electronic format documents, subject to Terms and Conditions for Electronic Documents at <http://www.sgs.com.tw/Terms-and-Conditions>. Attention is drawn to the limitation of liability, indemnification and jurisdiction issues defined therein. Any holder of this document is advised that information contained herein reflects the Company's findings at the time of its intervention only and within the limits of Client's instructions, if any. The Company's sole responsibility is to its Client and this document does not exonerate parties to a transaction from exercising all their rights and obligations under the transaction documents. This document cannot be reproduced except in full, without prior written approval of the Company. Any unauthorized alteration, forgery or falsification of the content or appearance of this document is unlawful and offenders may be prosecuted to the fullest extent of the law.

Report Number :TERF2309002194ER  
 Operation Mode :EDR 3M  
 Test Frequency :2402 MHz  
 Test Mode :Bandedge  
 EUT Pol :E2 Plane

Test Site :SAC 1  
 Test Date :2023-09-19  
 Temp./Humi. :24.0°C/62%  
 Antenna Pol. :Vertical  
 Engineer :Cooper Hsu

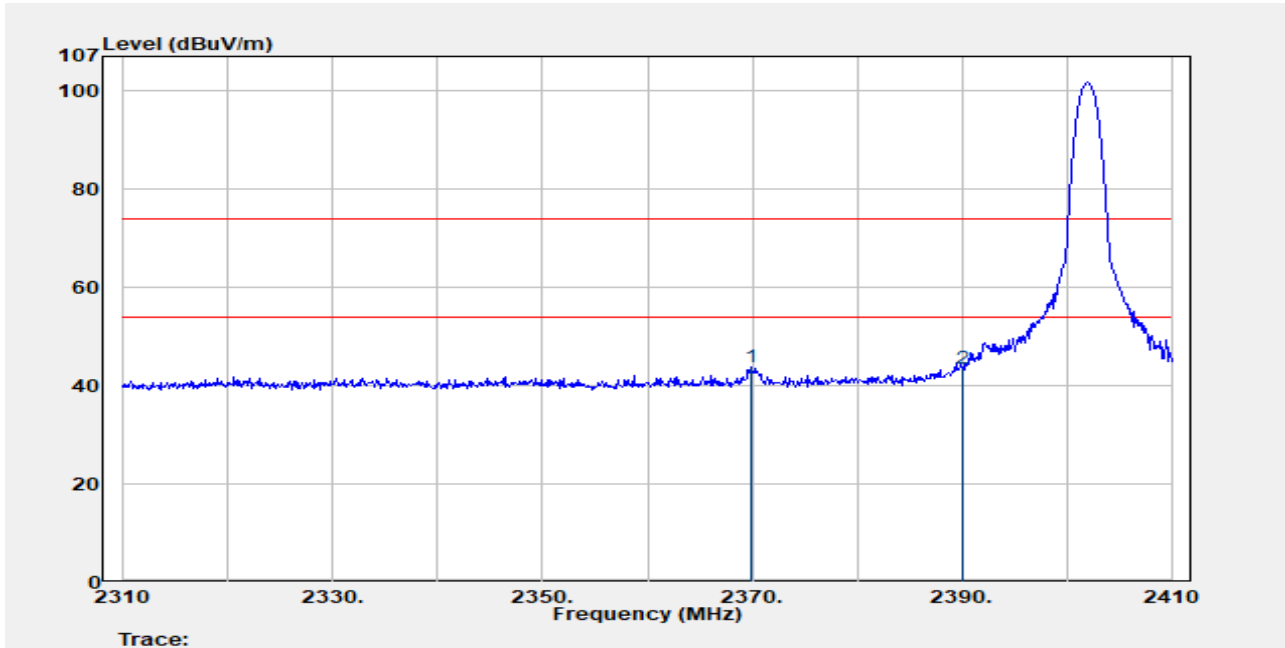

Freq. MHz	Detector Mode PK/QP/AV	Spectrum Reading Level d $\mu$ V	Factor dB	Actual FS d $\mu$ V/m	Limit @3m d $\mu$ V/m	Margin dB
2369.90	Peak	46.99	-3.31	43.67	74.00	-30.33
2390.00	Peak	46.79	-3.42	43.37	74.00	-30.63
Freq. MHz	Detector Mode AV	Peak Actual FS (d $\mu$ V/m)	Duty Cycle Factor (dB)	Average Value (d $\mu$ V/m)	Average Limit@3m (d $\mu$ V/m)	Margin (dB)
2369.900	Average	43.67	-25.46	18.21	54.00	-35.79
2390.000	Average	43.37	-25.46	17.91	54.00	-36.09

Unless otherwise stated the results shown in this test report refer only to the sample(s) tested and such sample(s) are retained for 90 days only.

除非另有說明，此報告結果僅對測試之樣品負責，同時此樣品僅保留90天。本報告未經本公司書面許可，不可部份複製。

This document is issued by the Company subject to its General Conditions of Service printed overleaf, available on request or accessible at <http://www.sgs.com.tw/Terms-and-Conditions> and for electronic format documents, subject to Terms and Conditions for Electronic Documents at <http://www.sgs.com.tw/Terms-and-Conditions>. Attention is drawn to the limitation of liability, indemnification and jurisdiction issues defined therein. Any holder of this document is advised that information contained herein reflects the Company's findings at the time of its intervention only and within the limits of Client's instructions, if any. The Company's sole responsibility is to its Client and this document does not exonerate parties to a transaction from exercising all their rights and obligations under the transaction documents. This document cannot be reproduced except in full, without prior written approval of the Company. Any unauthorized alteration, forgery or falsification of the content or appearance of this document is unlawful and offenders may be prosecuted to the fullest extent of the law.

Report Number :TERF2309002194ER  
 Operation Mode :EDR 3M  
 Test Frequency :2402 MHz  
 Test Mode :Bandedge  
 EUT Pol :E2 Plane

Test Site :SAC 1  
 Test Date :2023-09-19  
 Temp./Humi. :24.0°C/62%  
 Antenna Pol. :Horizontal  
 Engineer :Cooper Hsu

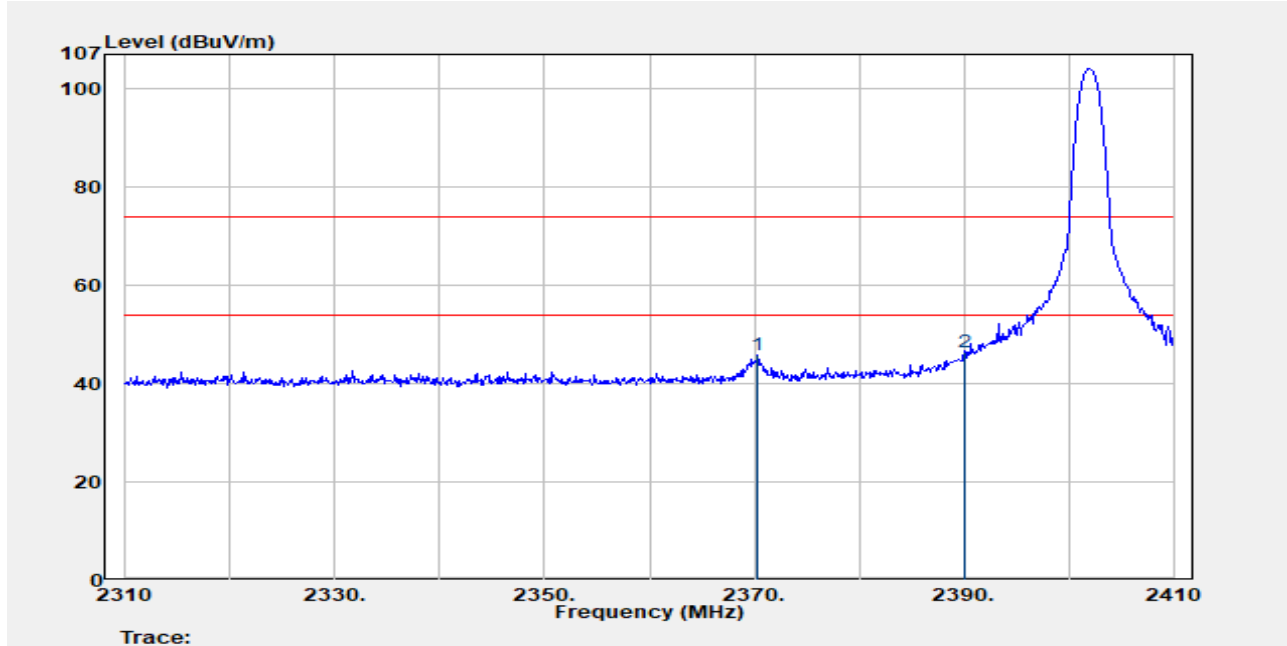

Freq. MHz	Detector Mode PK/QP/AV	Spectrum Reading Level d $\mu$ V	Factor dB	Actual FS d $\mu$ V/m	Limit @3m d $\mu$ V/m	Margin dB
2370.30	Peak	49.08	-3.32	45.76	74.00	-28.24
2390.00	Peak	49.91	-3.42	46.49	74.00	-27.51
Freq. MHz	Detector Mode AV	Peak Actual FS (d $\mu$ V/m)	Duty Cycle Factor (dB)	Average Value (d $\mu$ V/m)	Average Limit@3m (d $\mu$ V/m)	Margin (dB)
2370.300	Average	45.76	-25.46	20.30	54.00	-33.70
2390.000	Average	46.49	-25.46	21.03	54.00	-32.97

Unless otherwise stated the results shown in this test report refer only to the sample(s) tested and such sample(s) are retained for 90 days only.

除非另有說明，此報告結果僅對測試之樣品負責，同時此樣品僅保留90天。本報告未經本公司書面許可，不可部份複製。

This document is issued by the Company subject to its General Conditions of Service printed overleaf, available on request or accessible at <http://www.sgs.com.tw/Terms-and-Conditions> and for electronic format documents, subject to Terms and Conditions for Electronic Documents at <http://www.sgs.com.tw/Terms-and-Conditions>. Attention is drawn to the limitation of liability, indemnification and jurisdiction issues defined therein. Any holder of this document is advised that information contained herein reflects the Company's findings at the time of its intervention only and within the limits of Client's instructions, if any. The Company's sole responsibility is to its Client and this document does not exonerate parties to a transaction from exercising all their rights and obligations under the transaction documents. This document cannot be reproduced except in full, without prior written approval of the Company. Any unauthorized alteration, forgery or falsification of the content or appearance of this document is unlawful and offenders may be prosecuted to the fullest extent of the law.

Report Number :TERF2309002194ER  
 Operation Mode :EDR 3M  
 Test Frequency :2480 MHz  
 Test Mode :Bandedge  
 EUT Pol :E2 Plane

Test Site :SAC 1  
 Test Date :2023-09-19  
 Temp./Humi. :24.0°C/62%  
 Antenna Pol. :Vertical  
 Engineer :Cooper Hsu

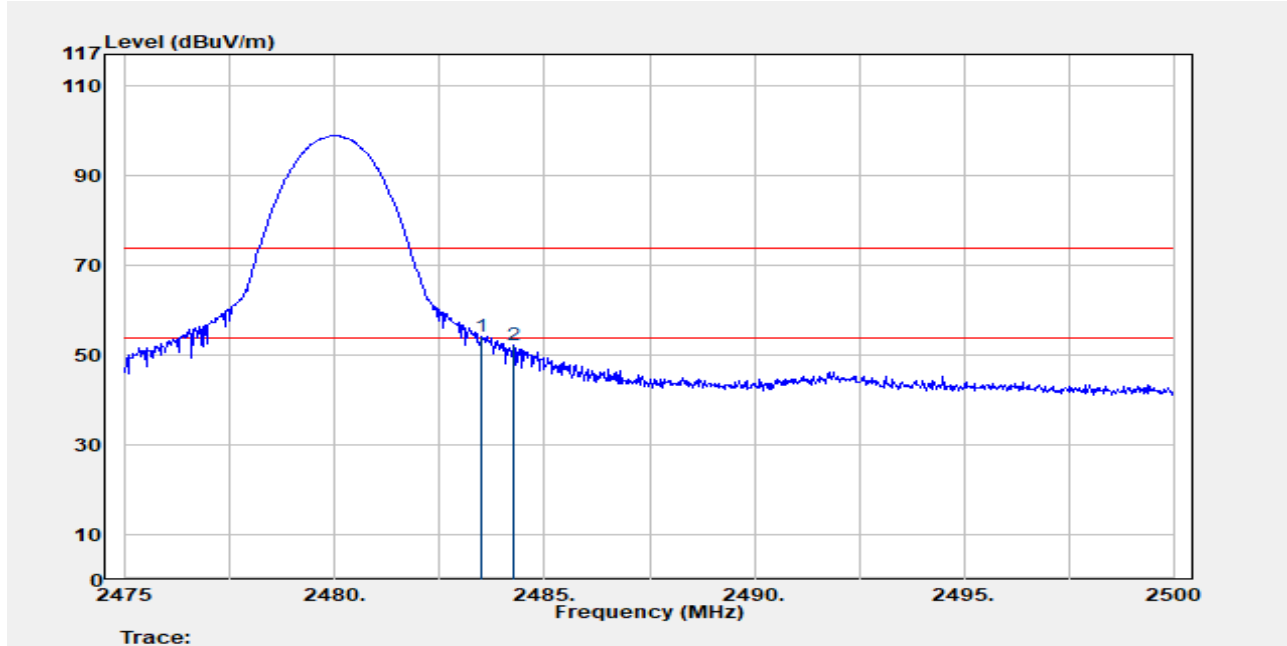

Freq. MHz	Detector Mode PK/QP/AV	Spectrum Reading Level dBμV	Factor dB	Actual FS dBμV/m	Limit @3m dBμV/m	Margin dB
2483.50	Peak	57.75	-3.45	54.30	74.00	-19.70
2484.25	Peak	55.66	-3.44	52.21	74.00	-21.79

Freq. MHz	Detector Mode AV	Peak Actual FS (dBμV/m)	Duty Cycle Factor (dB)	Average Value (dBuV/m)	Average Limit@3m (dBuV/m)	Margin (dB)
2483.500	Average	54.30	-25.46	28.84	54.00	-25.16
2484.250	Average	52.21	-25.46	26.75	54.00	-27.25

Unless otherwise stated the results shown in this test report refer only to the sample(s) tested and such sample(s) are retained for 90 days only.

除非另有說明，此報告結果僅對測試之樣品負責，同時此樣品僅保留90天。本報告未經本公司書面許可，不可部份複製。

This document is issued by the Company subject to its General Conditions of Service printed overleaf, available on request or accessible at <http://www.sgs.com.tw/Terms-and-Conditions> and for electronic format documents, subject to Terms and Conditions for Electronic Documents at <http://www.sgs.com.tw/Terms-and-Conditions>. Attention is drawn to the limitation of liability, indemnification and jurisdiction issues defined therein. Any holder of this document is advised that information contained herein reflects the Company's findings at the time of its intervention only and within the limits of Client's instructions, if any. The Company's sole responsibility is to its Client and this document does not exonerate parties to a transaction from exercising all their rights and obligations under the transaction documents. This document cannot be reproduced except in full, without prior written approval of the Company. Any unauthorized alteration, forgery or falsification of the content or appearance of this document is unlawful and offenders may be prosecuted to the fullest extent of the law.

Report Number :TERF2309002194ER  
 Operation Mode :EDR 3M  
 Test Frequency :2480 MHz  
 Test Mode :Bandedge  
 EUT Pol :E2 Plane

Test Site :SAC 1  
 Test Date :2023-09-19  
 Temp./Humi. :24.0°C/62%  
 Antenna Pol. :Horizontal  
 Engineer :Cooper Hsu

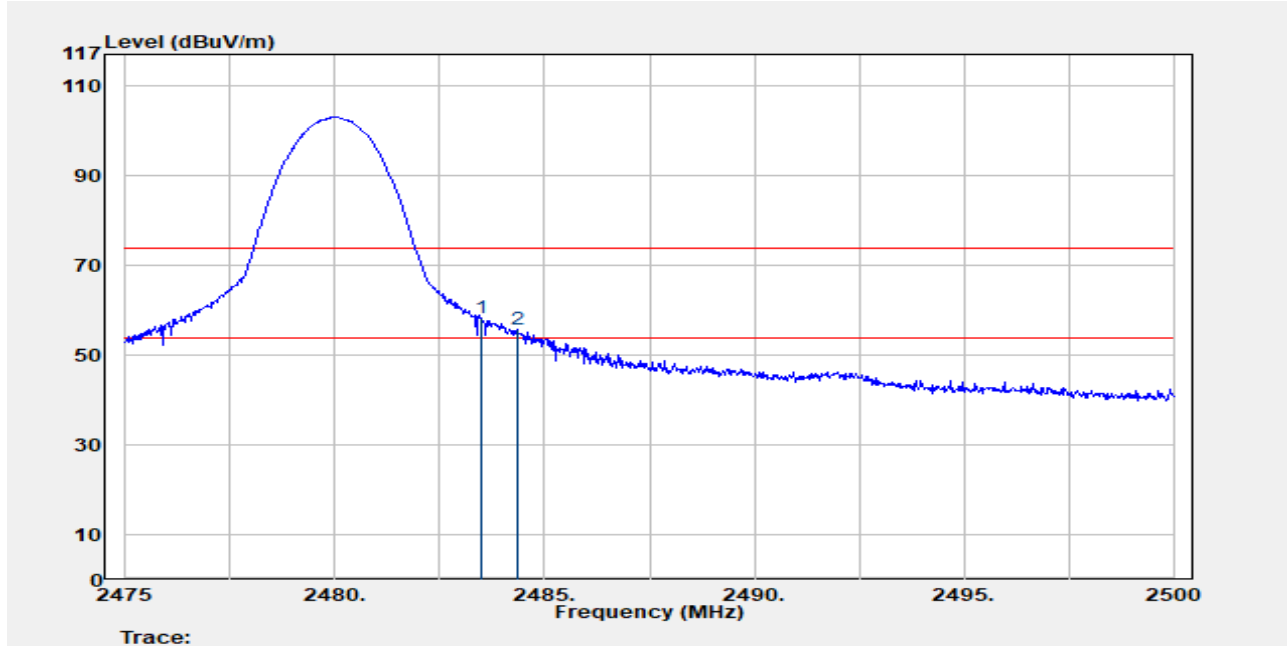

Freq. MHz	Detector Mode PK/QP/AV	Spectrum Reading Level dB $\mu$ V	Factor dB	Actual FS dB $\mu$ V/m	Limit @3m dB $\mu$ V/m	Margin dB
2483.50	Peak	61.67	-3.45	58.22	74.00	-15.78
2484.35	Peak	59.28	-3.44	55.84	74.00	-18.16

Freq. MHz	Detector Mode AV	Peak Actual FS (dB $\mu$ V/m)	Duty Cycle Factor (dB)	Average Value (dB $\mu$ V/m)	Average Limit@3m (dB $\mu$ V/m)	Margin (dB)
2483.500	Average	58.22	-25.46	32.76	54.00	-21.24
2484.350	Average	55.84	-25.46	30.38	54.00	-23.62

Unless otherwise stated the results shown in this test report refer only to the sample(s) tested and such sample(s) are retained for 90 days only.

除非另有說明，此報告結果僅對測試之樣品負責，同時此樣品僅保留90天。本報告未經本公司書面許可，不可部份複製。

This document is issued by the Company subject to its General Conditions of Service printed overleaf, available on request or accessible at <http://www.sgs.com.tw/Terms-and-Conditions> and for electronic format documents, subject to Terms and Conditions for Electronic Documents at <http://www.sgs.com.tw/Terms-and-Conditions>. Attention is drawn to the limitation of liability, indemnification and jurisdiction issues defined therein. Any holder of this document is advised that information contained herein reflects the Company's findings at the time of its intervention only and within the limits of Client's instructions, if any. The Company's sole responsibility is to its Client and this document does not exonerate parties to a transaction from exercising all their rights and obligations under the transaction documents. This document cannot be reproduced except in full, without prior written approval of the Company. Any unauthorized alteration, forgery or falsification of the content or appearance of this document is unlawful and offenders may be prosecuted to the fullest extent of the law.

Report Number :TERF2309002194ER  
 Operation Mode :BR Hopping  
 Test Frequency :2402 MHz  
 Test Mode :Bandedge  
 EUT Pol :E2 Plane

Test Site :SAC 1  
 Test Date :2023-09-19  
 Temp./Humi. :24.0°C/62%  
 Antenna Pol. :Vertical  
 Engineer :Cooper Hsu

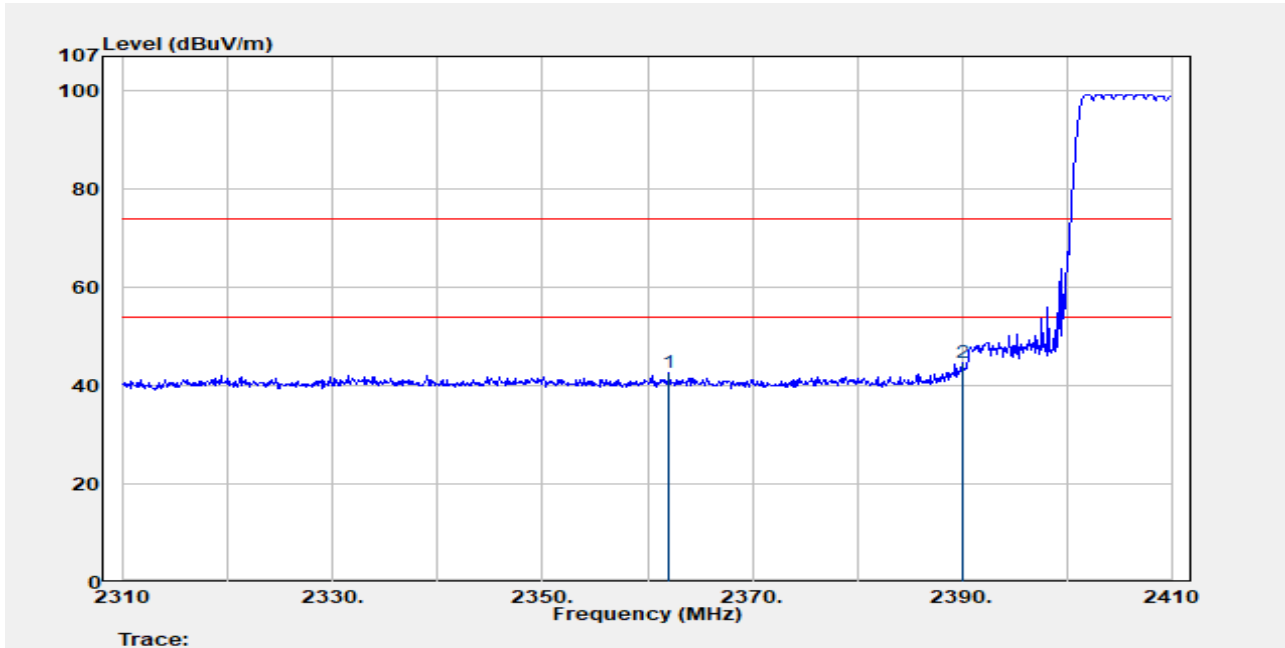

Freq. MHz	Detector Mode	Spectrum Reading Level d $\mu$ V	Factor dB	Actual FS d $\mu$ V/m	Limit @3m d $\mu$ V/m	Margin dB
2362.10	Peak	45.87	-3.27	42.60	74.00	-31.40
2390.00	Peak	47.95	-3.42	44.53	74.00	-29.47

Freq. MHz	Detector Mode	Peak Actual FS (d $\mu$ V/m)	Duty Cycle Factor (dB)	Average Value (d $\mu$ V/m)	Average Limit@3m (d $\mu$ V/m)	Margin (dB)
2362.100	Average	42.60	-24.93	17.67	54.00	-36.33
2390.000	Average	44.53	-24.93	19.60	54.00	-34.40

Unless otherwise stated the results shown in this test report refer only to the sample(s) tested and such sample(s) are retained for 90 days only.

除非另有說明，此報告結果僅對測試之樣品負責，同時此樣品僅保留90天。本報告未經本公司書面許可，不可部份複製。

This document is issued by the Company subject to its General Conditions of Service printed overleaf, available on request or accessible at <http://www.sgs.com.tw/Terms-and-Conditions> and for electronic format documents, subject to Terms and Conditions for Electronic Documents at <http://www.sgs.com.tw/Terms-and-Conditions>. Attention is drawn to the limitation of liability, indemnification and jurisdiction issues defined therein. Any holder of this document is advised that information contained hereon reflects the Company's findings at the time of its intervention only and within the limits of Client's instructions, if any. The Company's sole responsibility is to its Client and this document does not exonerate parties to a transaction from exercising all their rights and obligations under the transaction documents. This document cannot be reproduced except in full, without prior written approval of the Company. Any unauthorized alteration, forgery or falsification of the content or appearance of this document is unlawful and offenders may be prosecuted to the fullest extent of the law.

Report Number :TERF2309002194ER  
 Operation Mode :BR Hopping  
 Test Frequency :2402 MHz  
 Test Mode :Bandedge  
 EUT Pol :E2 Plane

Test Site :SAC 1  
 Test Date :2023-09-19  
 Temp./Humi. :24.0°C/62%  
 Antenna Pol. :Horizontal  
 Engineer :Cooper Hsu

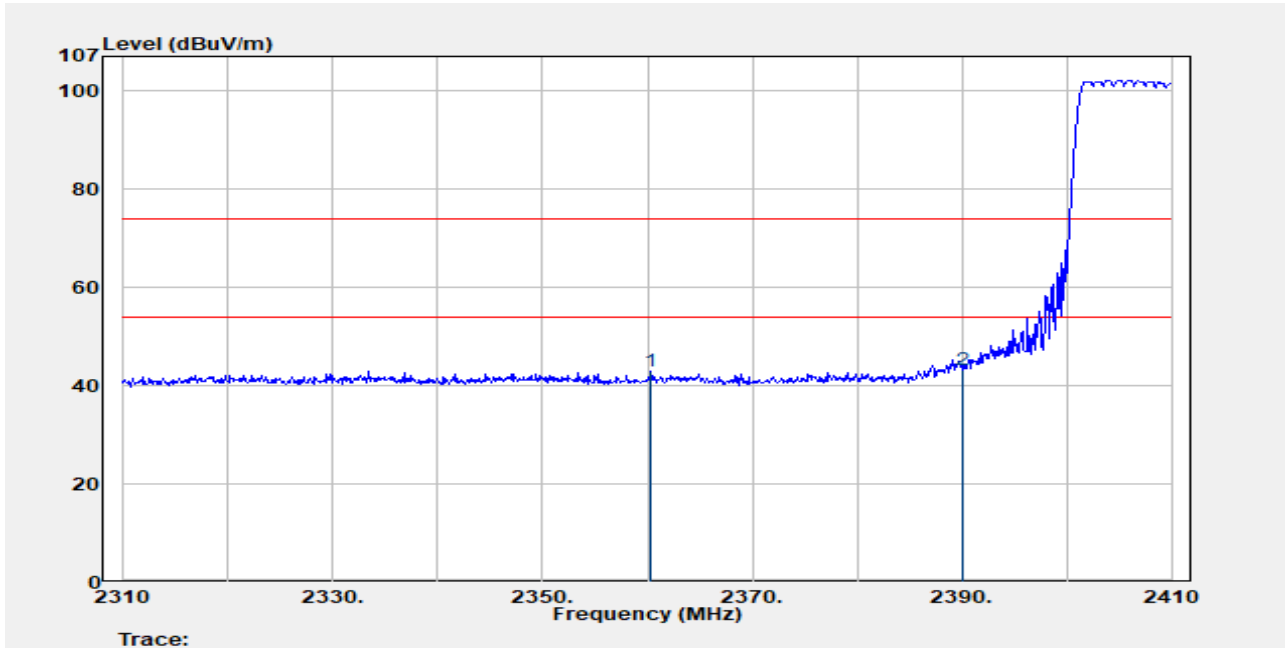

Freq. MHz	Detector Mode PK/QP/AV	Spectrum Reading Level d $\mu$ V	Factor dB	Actual FS d $\mu$ V/m	Limit @3m d $\mu$ V/m	Margin dB
2360.30	Peak	46.31	-3.26	43.05	74.00	-30.95
2390.00	Peak	46.69	-3.42	43.27	74.00	-30.73

Freq. MHz	Detector Mode AV	Peak Actual FS (d $\mu$ V/m)	Duty Cycle Factor (dB)	Average Value (d $\mu$ V/m)	Average Limit@3m (d $\mu$ V/m)	Margin (dB)
2360.300	Average	43.05	-24.93	18.12	54.00	-35.88
2390.000	Average	43.27	-24.93	18.34	54.00	-35.66

Unless otherwise stated the results shown in this test report refer only to the sample(s) tested and such sample(s) are retained for 90 days only.

除非另有說明，此報告結果僅對測試之樣品負責，同時此樣品僅保留90天。本報告未經本公司書面許可，不可部份複製。

This document is issued by the Company subject to its General Conditions of Service printed overleaf, available on request or accessible at <http://www.sgs.com.tw/Terms-and-Conditions> and for electronic format documents, subject to Terms and Conditions for Electronic Documents at <http://www.sgs.com.tw/Terms-and-Conditions>. Attention is drawn to the limitation of liability, indemnification and jurisdiction issues defined therein. Any holder of this document is advised that information contained hereon reflects the Company's findings at the time of its intervention only and within the limits of Client's instructions, if any. The Company's sole responsibility is to its Client and this document does not exonerate parties to a transaction from exercising all their rights and obligations under the transaction documents. This document cannot be reproduced except in full, without prior written approval of the Company. Any unauthorized alteration, forgery or falsification of the content or appearance of this document is unlawful and offenders may be prosecuted to the fullest extent of the law.



Report Number :TERF2309002194ER  
 Operation Mode :BR Hopping  
 Test Frequency :2480 MHz  
 Test Mode :Bandedge  
 EUT Pol :E2 Plane

Test Site :SAC 1  
 Test Date :2023-09-19  
 Temp./Humi. :24.0°C/62%  
 Antenna Pol. :Vertical  
 Engineer :Cooper Hsu

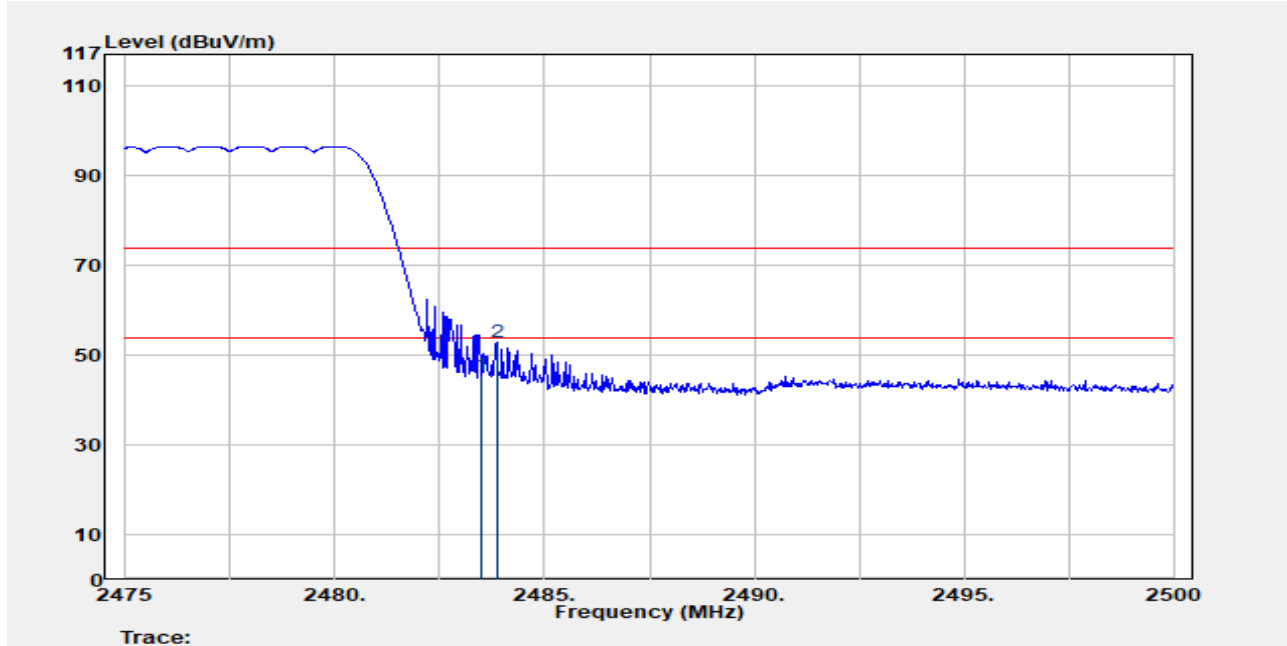

Freq. MHz	Detector Mode PK/QP/AV	Spectrum Reading Level d $\mu$ V	Factor dB	Actual FS d $\mu$ V/m	Limit @3m d $\mu$ V/m	Margin dB
2483.50	Peak	49.12	-3.45	45.67	74.00	-28.33
2483.85	Peak	56.29	-3.44	52.84	74.00	-21.16

Freq. MHz	Detector Mode AV	Peak Actual FS (d $\mu$ V/m)	Duty Cycle Factor (dB)	Average Value (d $\mu$ V/m)	Average Limit@3m (d $\mu$ V/m)	Margin (dB)
2483.500	Average	45.67	-24.93	20.74	54.00	-33.26
2483.850	Average	52.84	-24.93	27.91	54.00	-26.09

Unless otherwise stated the results shown in this test report refer only to the sample(s) tested and such sample(s) are retained for 90 days only.

除非另有說明，此報告結果僅對測試之樣品負責，同時此樣品僅保留90天。本報告未經本公司書面許可，不可部份複製。

This document is issued by the Company subject to its General Conditions of Service printed overleaf, available on request or accessible at <http://www.sgs.com.tw/Terms-and-Conditions>, and for electronic format documents, subject to Terms and Conditions for Electronic Documents at <http://www.sgs.com.tw/Terms-and-Conditions>. Attention is drawn to the limitation of liability, indemnification and jurisdiction issues defined therein. Any holder of this document is advised that information contained hereon reflects the Company's findings at the time of its intervention only and within the limits of Client's instructions, if any. The Company's sole responsibility is to its Client and this document does not exonerate parties to a transaction from exercising all their rights and obligations under the transaction documents. This document cannot be reproduced except in full, without prior written approval of the Company. Any unauthorized alteration, forgery or falsification of the content or appearance of this document is unlawful and offenders may be prosecuted to the fullest extent of the law.

Report Number :TERF2309002194ER  
 Operation Mode :BR Hopping  
 Test Frequency :2480 MHz  
 Test Mode :Bandedge  
 EUT Pol :E2 Plane

Test Site :SAC 1  
 Test Date :2023-09-19  
 Temp./Humi. :24.0°C/62%  
 Antenna Pol. :Horizontal  
 Engineer :Cooper Hsu

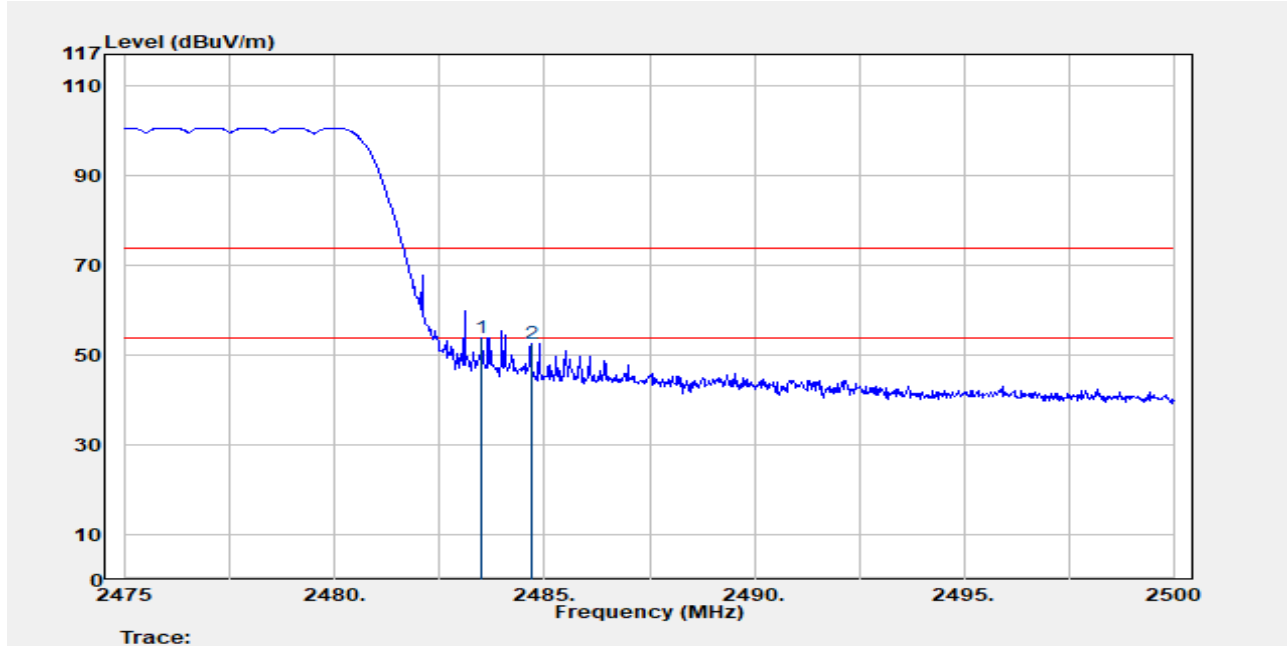

Freq. MHz	Detector Mode PK/QP/AV	Spectrum Reading Level d $\mu$ V	Factor dB	Actual FS d $\mu$ V/m	Limit @3m d $\mu$ V/m	Margin dB
2483.50	Peak	57.24	-3.45	53.79	74.00	-20.21
2484.68	Peak	56.22	-3.44	52.78	74.00	-21.22

Freq. MHz	Detector Mode AV	Peak Actual FS (d $\mu$ V/m)	Duty Cycle Factor (dB)	Average Value (d $\mu$ V/m)	Average Limit@3m (d $\mu$ V/m)	Margin (dB)
2483.500	Average	53.79	-24.93	28.86	54.00	-25.14
2484.680	Average	52.78	-24.93	27.85	54.00	-26.15

Unless otherwise stated the results shown in this test report refer only to the sample(s) tested and such sample(s) are retained for 90 days only.

除非另有說明，此報告結果僅對測試之樣品負責，同時此樣品僅保留90天。本報告未經本公司書面許可，不可部份複製。

This document is issued by the Company subject to its General Conditions of Service printed overleaf, available on request or accessible at <http://www.sgs.com.tw/Terms-and-Conditions> and for electronic format documents, subject to Terms and Conditions for Electronic Documents at <http://www.sgs.com.tw/Terms-and-Conditions>. Attention is drawn to the limitation of liability, indemnification and jurisdiction issues defined therein. Any holder of this document is advised that information contained hereon reflects the Company's findings at the time of its intervention only and within the limits of Client's instructions, if any. The Company's sole responsibility is to its Client and this document does not exonerate parties to a transaction from exercising all their rights and obligations under the transaction documents. This document cannot be reproduced except in full, without prior written approval of the Company. Any unauthorized alteration, forgery or falsification of the content or appearance of this document is unlawful and offenders may be prosecuted to the fullest extent of the law.

Report Number :TERF2309002194ER  
 Operation Mode :EDR 3M Hopping  
 Test Frequency :2402 MHz  
 Test Mode :Bandedge  
 EUT Pol :E2 Plane

Test Site :SAC 1  
 Test Date :2023-09-19  
 Temp./Humi. :24.0°C/62%  
 Antenna Pol. :Vertical  
 Engineer :Cooper Hsu

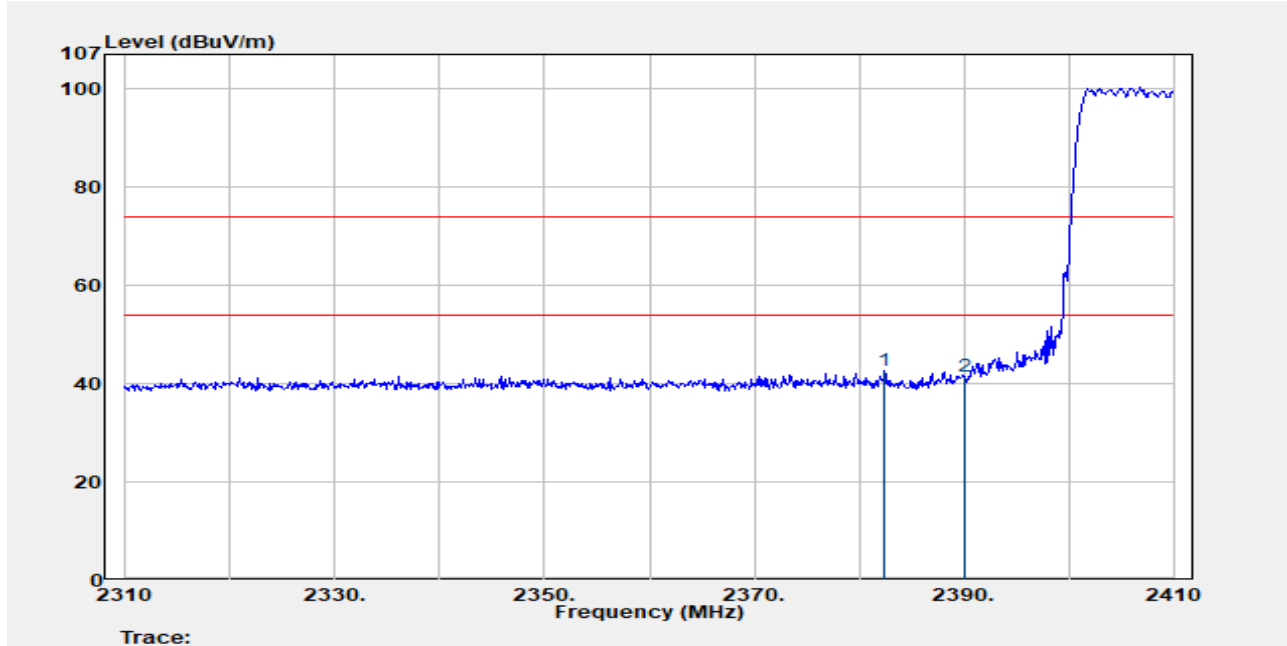

Freq. MHz	Detector Mode PK/QP/AV	Spectrum Reading Level d $\mu$ V	Factor dB	Actual FS d $\mu$ V/m	Limit @3m d $\mu$ V/m	Margin dB
2382.40	Peak	45.86	-3.38	42.49	74.00	-31.51
2390.00	Peak	44.83	-3.42	41.41	74.00	-32.59
Freq. MHz	Detector Mode AV	Peak Actual FS (d $\mu$ V/m)	Duty Cycle Factor (dB)	Average Value (d $\mu$ V/m)	Average Limit@3m (d $\mu$ V/m)	Margin (dB)
2382.400	Average	42.49	-25.46	17.03	54.00	-36.97
2390.000	Average	41.41	-25.46	15.95	54.00	-38.05

Unless otherwise stated the results shown in this test report refer only to the sample(s) tested and such sample(s) are retained for 90 days only.

除非另有說明，此報告結果僅對測試之樣品負責，同時此樣品僅保留90天。本報告未經本公司書面許可，不可部份複製。

This document is issued by the Company subject to its General Conditions of Service printed overleaf, available on request or accessible at <http://www.sgs.com.tw/Terms-and-Conditions> and for electronic format documents, subject to Terms and Conditions for Electronic Documents at <http://www.sgs.com.tw/Terms-and-Conditions>. Attention is drawn to the limitation of liability, indemnification and jurisdiction issues defined therein. Any holder of this document is advised that information contained hereon reflects the Company's findings at the time of its intervention only and within the limits of Client's instructions, if any. The Company's sole responsibility is to its Client and this document does not exonerate parties to a transaction from exercising all their rights and obligations under the transaction documents. This document cannot be reproduced except in full, without prior written approval of the Company. Any unauthorized alteration, forgery or falsification of the content or appearance of this document is unlawful and offenders may be prosecuted to the fullest extent of the law.

Report Number :TERF2309002194ER  
 Operation Mode :EDR 3M Hopping  
 Test Frequency :2402 MHz  
 Test Mode :Bandedge  
 EUT Pol :E2 Plane

Test Site :SAC 1  
 Test Date :2023-09-19  
 Temp./Humi. :24.0°C/62%  
 Antenna Pol. :Horizontal  
 Engineer :Cooper Hsu

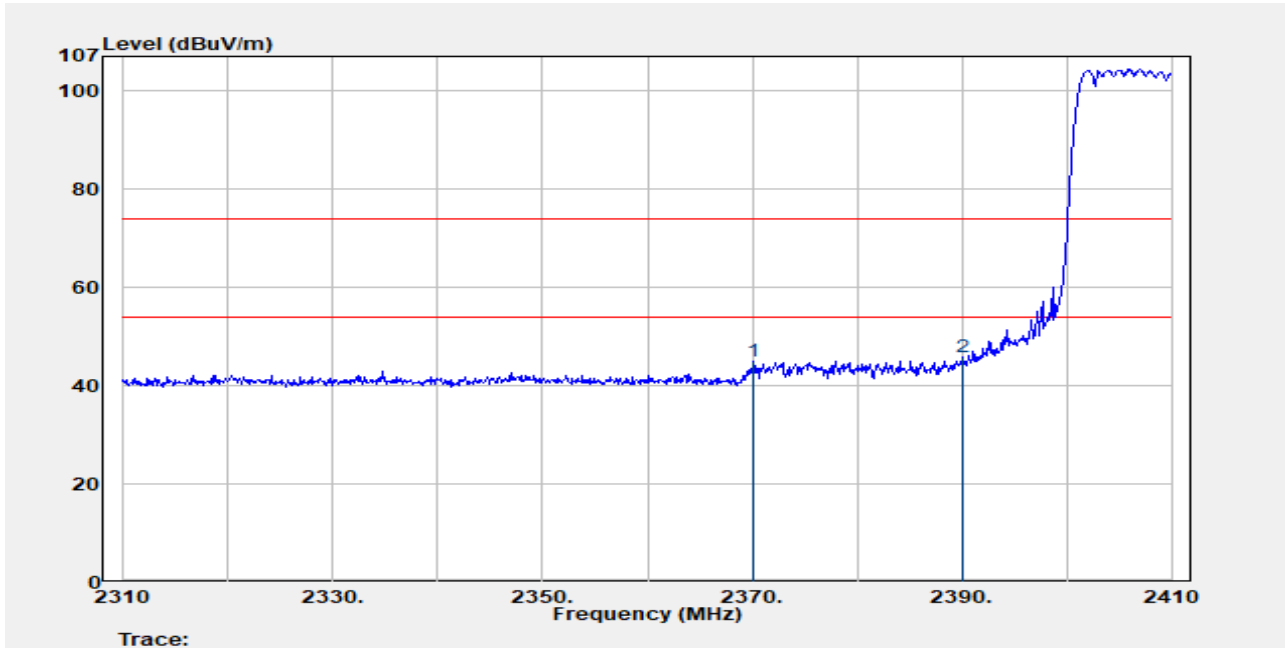

Freq. MHz	Detector Mode PK/QP/AV	Spectrum Reading Level d $\mu$ V	Factor dB	Actual FS d $\mu$ V/m	Limit @3m d $\mu$ V/m	Margin dB
2370.10	Peak	48.15	-3.31	44.83	74.00	-29.17
2390.00	Peak	49.11	-3.42	45.69	74.00	-28.31
Freq. MHz	Detector Mode AV	Peak Actual FS (d $\mu$ V/m)	Duty Cycle Factor (dB)	Average Value (d $\mu$ V/m)	Average Limit@3m (d $\mu$ V/m)	Margin (dB)
2370.100	Average	44.83	-25.46	19.37	54.00	-34.63
2390.000	Average	45.69	-25.46	20.23	54.00	-33.77

Unless otherwise stated the results shown in this test report refer only to the sample(s) tested and such sample(s) are retained for 90 days only.

除非另有說明，此報告結果僅對測試之樣品負責，同時此樣品僅保留90天。本報告未經本公司書面許可，不可部份複製。

This document is issued by the Company subject to its General Conditions of Service printed overleaf, available on request or accessible at <http://www.sgs.com.tw/Terms-and-Conditions> and for electronic format documents, subject to Terms and Conditions for Electronic Documents at <http://www.sgs.com.tw/Terms-and-Conditions>. Attention is drawn to the limitation of liability, indemnification and jurisdiction issues defined therein. Any holder of this document is advised that information contained herein reflects the Company's findings at the time of its intervention only and within the limits of Client's instructions, if any. The Company's sole responsibility is to its Client and this document does not exonerate parties to a transaction from exercising all their rights and obligations under the transaction documents. This document cannot be reproduced except in full, without prior written approval of the Company. Any unauthorized alteration, forgery or falsification of the content or appearance of this document is unlawful and offenders may be prosecuted to the fullest extent of the law.

Report Number :TERF2309002194ER  
 Operation Mode :EDR 3M Hopping  
 Test Frequency :2480 MHz  
 Test Mode :Bandedge  
 EUT Pol :E2 Plane

Test Site :SAC 1  
 Test Date :2023-09-19  
 Temp./Humi. :24.0°C/62%  
 Antenna Pol. :Vertical  
 Engineer :Cooper Hsu

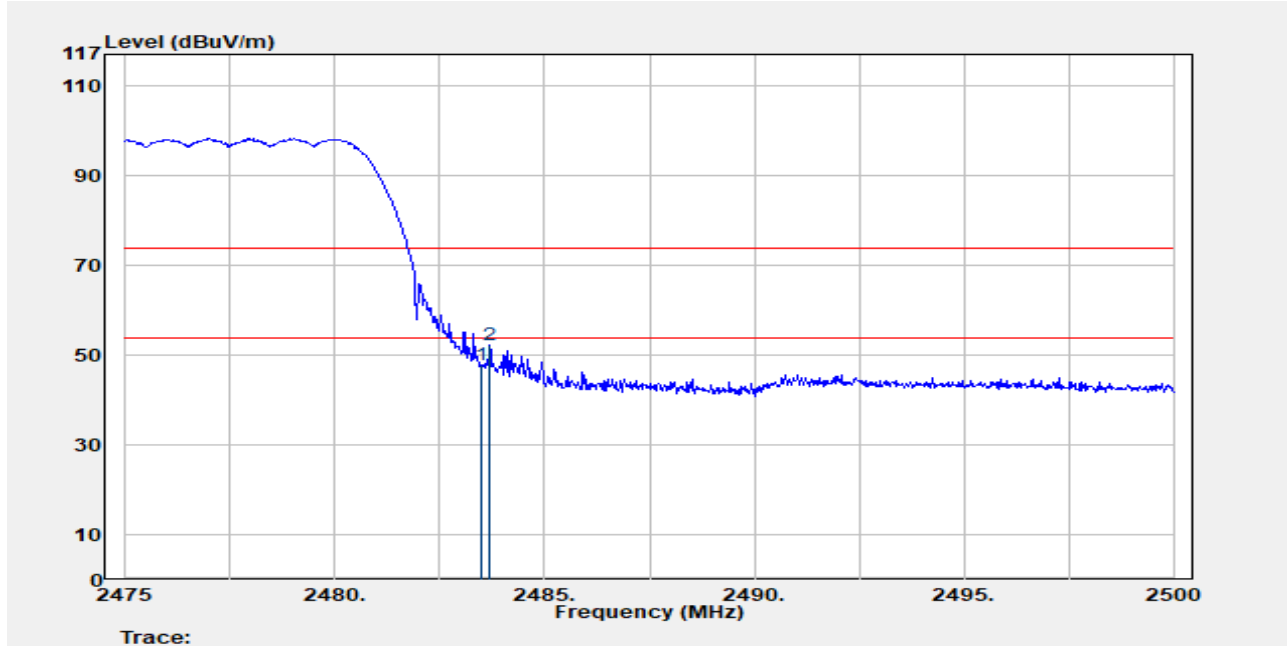

Freq. MHz	Detector Mode PK/QP/AV	Spectrum Reading Level d $\mu$ V	Factor dB	Actual FS d $\mu$ V/m	Limit @3m d $\mu$ V/m	Margin dB
2483.50	Peak	51.46	-3.45	48.01	74.00	-25.99
2483.70	Peak	55.72	-3.45	52.27	74.00	-21.73

Freq. MHz	Detector Mode AV	Peak Actual FS (d $\mu$ V/m)	Duty Cycle Factor (dB)	Average Value (d $\mu$ V/m)	Average Limit@3m (d $\mu$ V/m)	Margin (dB)
2483.500	Average	48.01	-25.46	22.55	54.00	-31.45
2483.700	Average	52.27	-25.46	26.81	54.00	-27.19

Unless otherwise stated the results shown in this test report refer only to the sample(s) tested and such sample(s) are retained for 90 days only.

除非另有說明，此報告結果僅對測試之樣品負責，同時此樣品僅保留90天。本報告未經本公司書面許可，不可部份複製。

This document is issued by the Company subject to its General Conditions of Service printed overleaf, available on request or accessible at <http://www.sgs.com.tw/Terms-and-Conditions> and for electronic format documents, subject to Terms and Conditions for Electronic Documents at <http://www.sgs.com.tw/Terms-and-Conditions>. Attention is drawn to the limitation of liability, indemnification and jurisdiction issues defined therein. Any holder of this document is advised that information contained herein reflects the Company's findings at the time of its intervention only and within the limits of Client's instructions, if any. The Company's sole responsibility is to its Client and this document does not exonerate parties to a transaction from exercising all their rights and obligations under the transaction documents. This document cannot be reproduced except in full, without prior written approval of the Company. Any unauthorized alteration, forgery or falsification of the content or appearance of this document is unlawful and offenders may be prosecuted to the fullest extent of the law.

Report Number :TERF2309002194ER  
 Operation Mode :EDR 3M Hopping  
 Test Frequency :2480 MHz  
 Test Mode :Bandedge  
 EUT Pol :E2 Plane

Test Site :SAC 1  
 Test Date :2023-09-19  
 Temp./Humi. :24.0°C/62%  
 Antenna Pol. :Horizontal  
 Engineer :Cooper Hsu

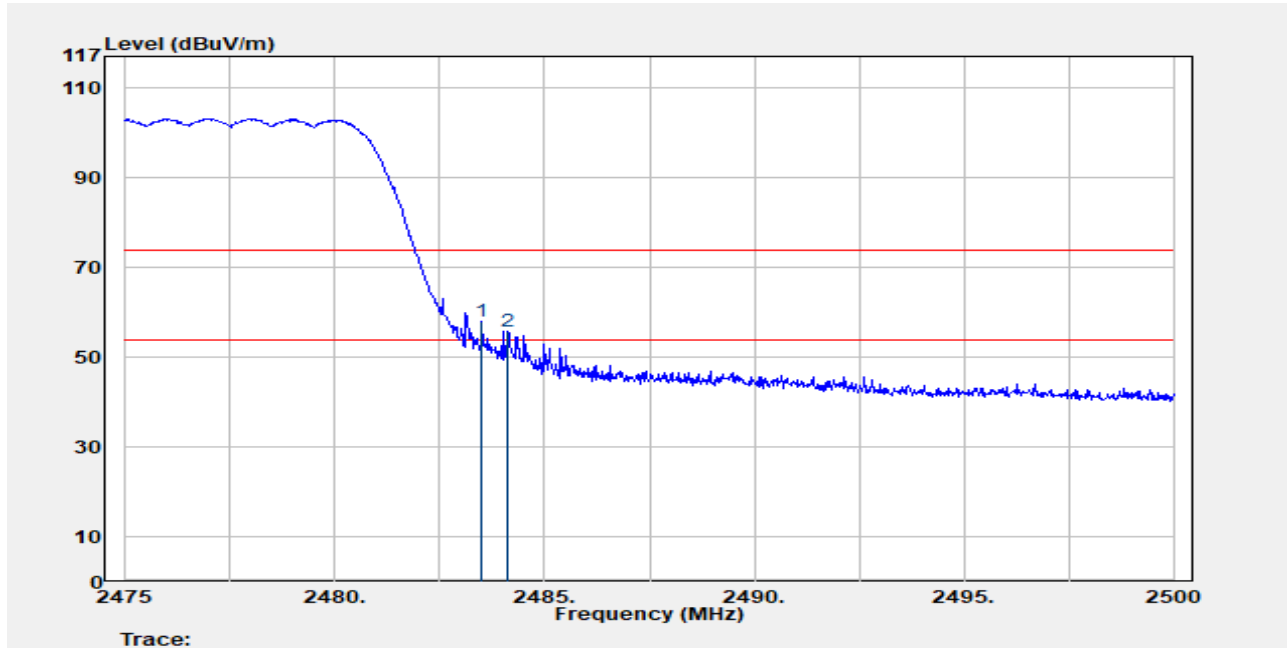

Freq. MHz	Detector Mode PK/QP/AV	Spectrum Reading Level d $\mu$ V	Factor dB	Actual FS d $\mu$ V/m	Limit @3m d $\mu$ V/m	Margin dB
2483.50	Peak	61.37	-3.45	57.92	74.00	-16.08
2484.13	Peak	59.23	-3.44	55.79	74.00	-18.21

Freq. MHz	Detector Mode AV	Peak Actual FS (d $\mu$ V/m)	Duty Cycle Factor (dB)	Average Value (d $\mu$ V/m)	Average Limit@3m (d $\mu$ V/m)	Margin (dB)
2483.500	Average	57.92	-25.46	32.46	54.00	-21.54
2484.130	Average	55.79	-25.46	30.33	54.00	-23.67

Unless otherwise stated the results shown in this test report refer only to the sample(s) tested and such sample(s) are retained for 90 days only.

除非另有說明，此報告結果僅對測試之樣品負責，同時此樣品僅保留90天。本報告未經本公司書面許可，不可部份複製。

This document is issued by the Company subject to its General Conditions of Service printed overleaf, available on request or accessible at <http://www.sgs.com.tw/Terms-and-Conditions> and for electronic format documents, subject to Terms and Conditions for Electronic Documents at <http://www.sgs.com.tw/Terms-and-Conditions>. Attention is drawn to the limitation of liability, indemnification and jurisdiction issues defined therein. Any holder of this document is advised that information contained hereon reflects the Company's findings at the time of its intervention only and within the limits of Client's instructions, if any. The Company's sole responsibility is to its Client and this document does not exonerate parties to a transaction from exercising all their rights and obligations under the transaction documents. This document cannot be reproduced except in full, without prior written approval of the Company. Any unauthorized alteration, forgery or falsification of the content or appearance of this document is unlawful and offenders may be prosecuted to the fullest extent of the law.

### 11.6.4 Radiated Spurious Emission

1<sup>st</sup>

Report Number :TERF2309002194ER  
 Operation Mode :EDR 3M  
 Test Frequency :2441 MHz  
 Test Mode :Tx  
 EUT Pol :E2 Plane

Test Site :SAC 1  
 Test Date :2023-09-19  
 Temp./Humi. :24.0°C/62%  
 Antenna Pol. :Vertical  
 Engineer :Cooper Hsu

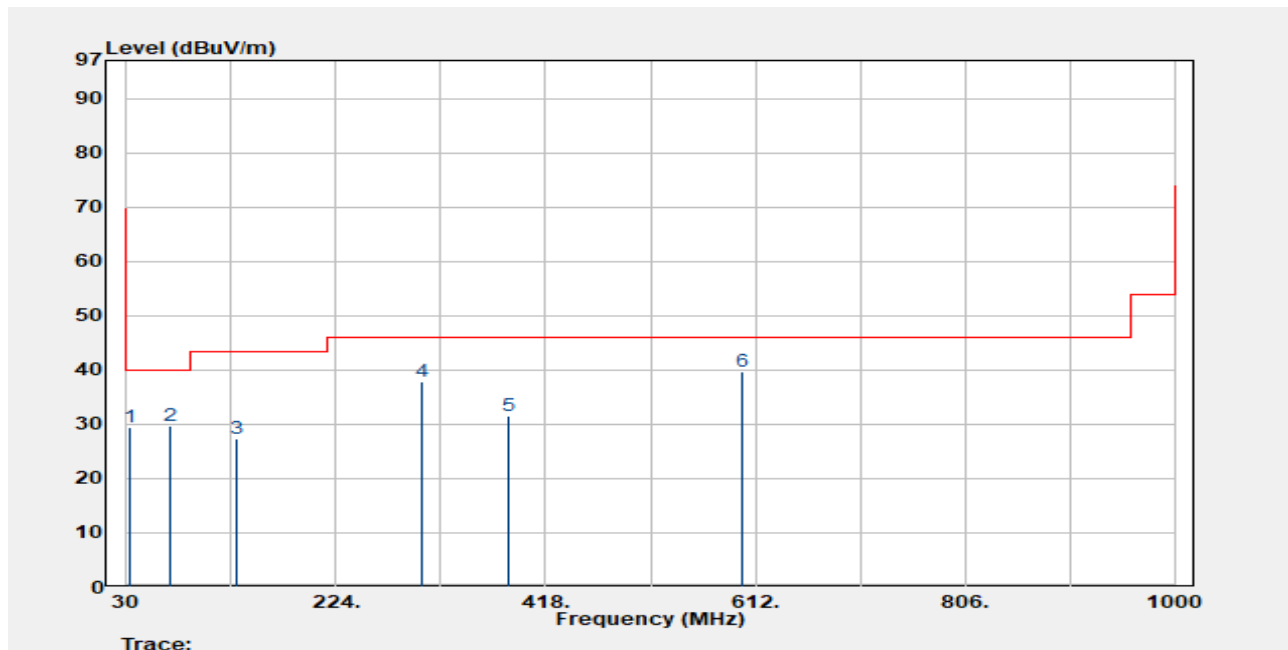

Freq. MHz	Detector Mode PK/QP/AV	Spectrum Reading Level dBUV	Factor dB	Actual FS dBUV/m	Limit @3m dBUV/m	Margin dB
32.91	Peak	36.38	-6.82	29.56	40.00	-10.44
69.77	Peak	47.69	-18.05	29.64	40.00	-10.36
131.85	Peak	39.42	-12.16	27.27	43.50	-16.23
303.54	Peak	47.23	-9.25	37.97	46.00	-8.03
384.05	Peak	39.34	-7.69	31.65	46.00	-14.35
600.36	Peak	43.52	-3.88	39.63	46.00	-6.37

Unless otherwise stated the results shown in this test report refer only to the sample(s) tested and such sample(s) are retained for 90 days only.

除非另有說明，此報告結果僅對測試之樣品負責，同時此樣品僅保留90天。本報告未經本公司書面許可，不可部份複製。

This document is issued by the Company subject to its General Conditions of Service printed overleaf, available on request or accessible at <http://www.sgs.com.tw/Terms-and-Conditions> and for electronic format documents, subject to Terms and Conditions for Electronic Documents at <http://www.sgs.com.tw/Terms-and-Conditions>. Attention is drawn to the limitation of liability, indemnification and jurisdiction issues defined therein. Any holder of this document is advised that information contained hereon reflects the Company's findings at the time of its intervention only and within the limits of Client's instructions, if any. The Company's sole responsibility is to its Client and this document does not exonerate parties to a transaction from exercising all their rights and obligations under the transaction documents. This document cannot be reproduced except in full, without prior written approval of the Company. Any unauthorized alteration, forgery or falsification of the content or appearance of this document is unlawful and offenders may be prosecuted to the fullest extent of the law.

Report Number :TERF2309002194ER  
 Operation Mode :EDR 3M  
 Test Frequency :2441 MHz  
 Test Mode :Tx  
 EUT Pol :E2 Plane

Test Site :SAC 1  
 Test Date :2023-09-19  
 Temp./Humi. :24.0°C/62%  
 Antenna Pol. :Horizontal  
 Engineer :Cooper Hsu

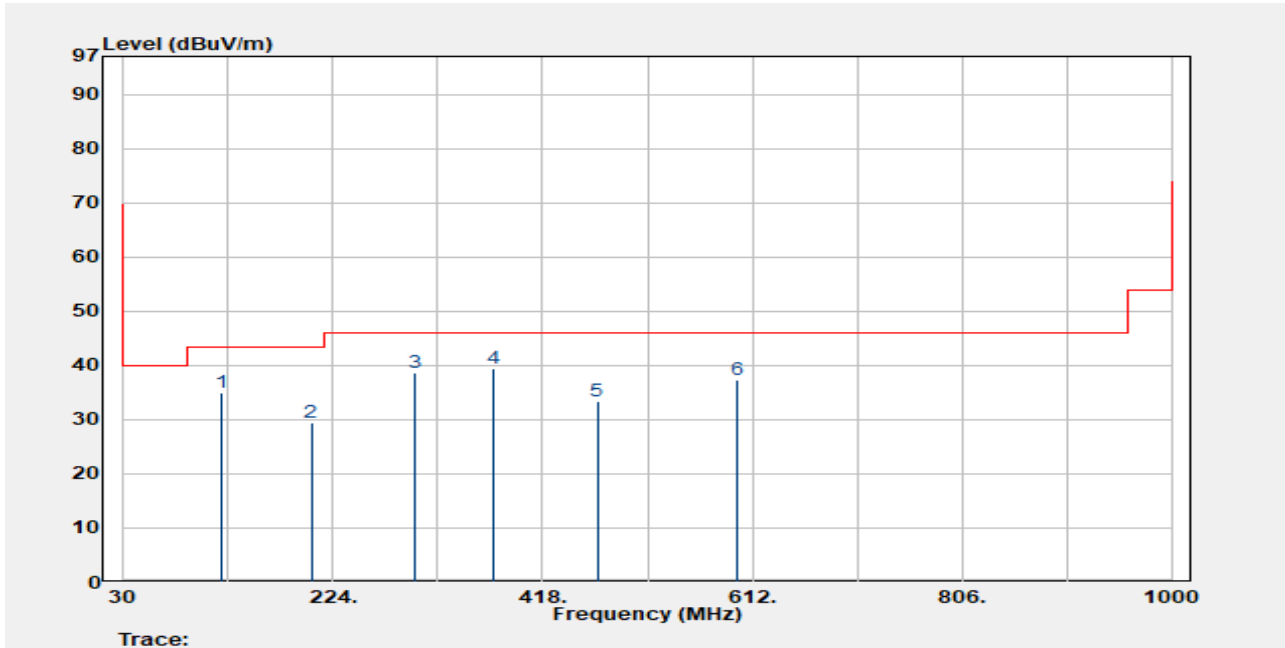

Freq. MHz	Detector Mode PK/QP/AV	Spectrum Reading Level dB $\mu$ V	Factor dB	Actual FS dB $\mu$ V/m	Limit @3m dB $\mu$ V/m	Margin dB
120.21	Peak	46.78	-11.89	34.89	43.50	-8.61
203.63	Peak	43.15	-13.62	29.53	43.50	-13.97
299.66	Peak	48.05	-9.33	38.72	46.00	-7.28
372.41	Peak	47.44	-7.91	39.53	46.00	-6.47
468.44	Peak	39.16	-5.90	33.25	46.00	-12.75
598.42	Peak	41.22	-3.87	37.34	46.00	-8.66

Unless otherwise stated the results shown in this test report refer only to the sample(s) tested and such sample(s) are retained for 90 days only.

除非另有說明，此報告結果僅對測試之樣品負責，同時此樣品僅保留90天。本報告未經本公司書面許可，不可部份複製。

This document is issued by the Company subject to its General Conditions of Service printed overleaf, available on request or accessible at <http://www.sgs.com.tw/Terms-and-Conditions> and for electronic format documents, subject to Terms and Conditions for Electronic Documents at <http://www.sgs.com.tw/Terms-and-Conditions>. Attention is drawn to the limitation of liability, indemnification and jurisdiction issues defined therein. Any holder of this document is advised that information contained hereon reflects the Company's findings at the time of its intervention only and within the limits of Client's instructions, if any. The Company's sole responsibility is to its Client and this document does not exonerate parties to a transaction from exercising all their rights and obligations under the transaction documents. This document cannot be reproduced except in full, without prior written approval of the Company. Any unauthorized alteration, forgery or falsification of the content or appearance of this document is unlawful and offenders may be prosecuted to the fullest extent of the law.



Report Number :TERF2309002194ER  
 Operation Mode :BR  
 Test Frequency :2402 MHz  
 Test Mode :Tx  
 EUT Pol :E2 Plane

Test Site :SAC 1  
 Test Date :2023-09-19  
 Temp./Humi. :24.0°C/62%  
 Antenna Pol. :Vertical  
 Engineer :Cooper Hsu

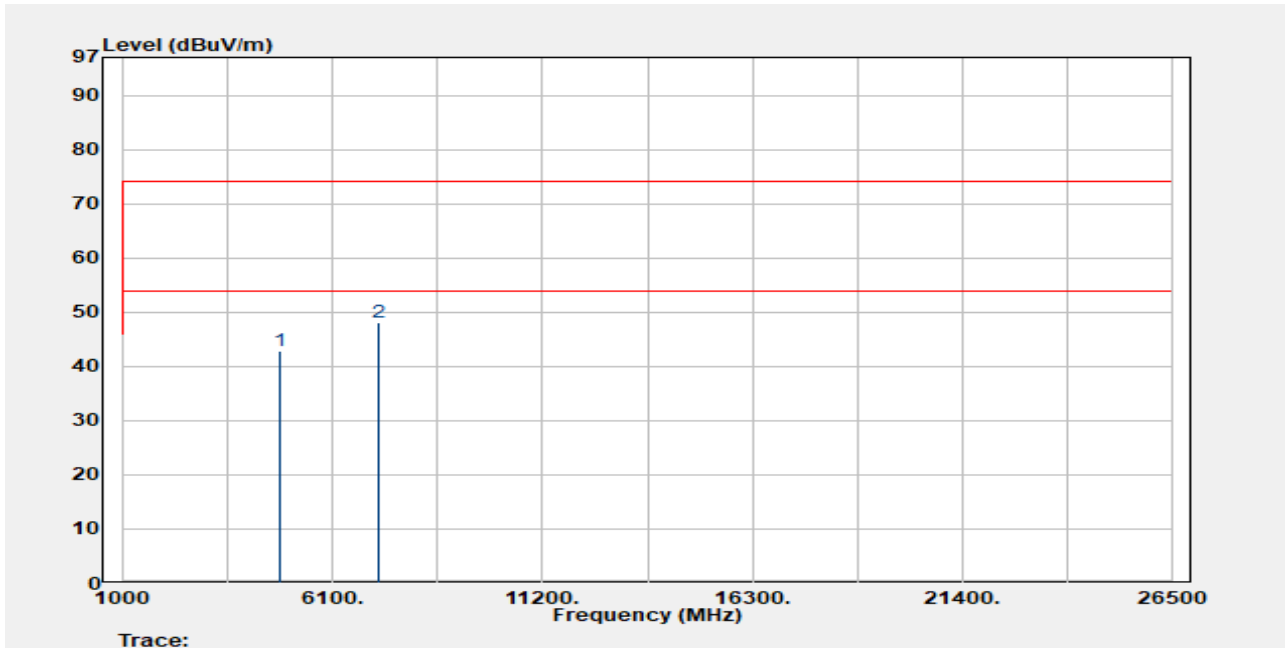

Freq. MHz	Detector Mode PK/QP/AV	Spectrum Reading Level dBuV	Factor dB	Actual FS dBuV/m	Limit @3m dBuV/m	Margin dB
4804.00	Peak	41.09	1.87	42.97	74.00	-31.03
7206.00	Peak	40.59	7.47	48.06	74.00	-25.94

Freq. MHz	Detector Mode AV	Peak Actual FS (dBuV/m)	Duty Cycle Factor (dB)	Average Value (dBuV/m)	Average Limit@3m (dBuV/m)	Margin (dB)
4804.000	Average	42.97	-24.93	18.04	54.00	-35.96
7206.000	Average	48.06	-24.93	23.13	54.00	-30.87

Unless otherwise stated the results shown in this test report refer only to the sample(s) tested and such sample(s) are retained for 90 days only.

除非另有說明，此報告結果僅對測試之樣品負責，同時此樣品僅保留90天。本報告未經本公司書面許可，不可部份複製。

This document is issued by the Company subject to its General Conditions of Service printed overleaf, available on request or accessible at <http://www.sgs.com.tw/Terms-and-Conditions> and for electronic format documents, subject to Terms and Conditions for Electronic Documents at <http://www.sgs.com.tw/Terms-and-Conditions>. Attention is drawn to the limitation of liability, indemnification and jurisdiction issues defined therein. Any holder of this document is advised that information contained hereon reflects the Company's findings at the time of its intervention only and within the limits of Client's instructions, if any. The Company's sole responsibility is to its Client and this document does not exonerate parties to a transaction from exercising all their rights and obligations under the transaction documents. This document cannot be reproduced except in full, without prior written approval of the Company. Any unauthorized alteration, forgery or falsification of the content or appearance of this document is unlawful and offenders may be prosecuted to the fullest extent of the law.

Report Number :TERF2309002194ER  
 Operation Mode :BR  
 Test Frequency :2402 MHz  
 Test Mode :Tx  
 EUT Pol :E2 Plane

Test Site :SAC 1  
 Test Date :2023-09-19  
 Temp./Humi. :24.0°C/62%  
 Antenna Pol. :Horizontal  
 Engineer :Cooper Hsu

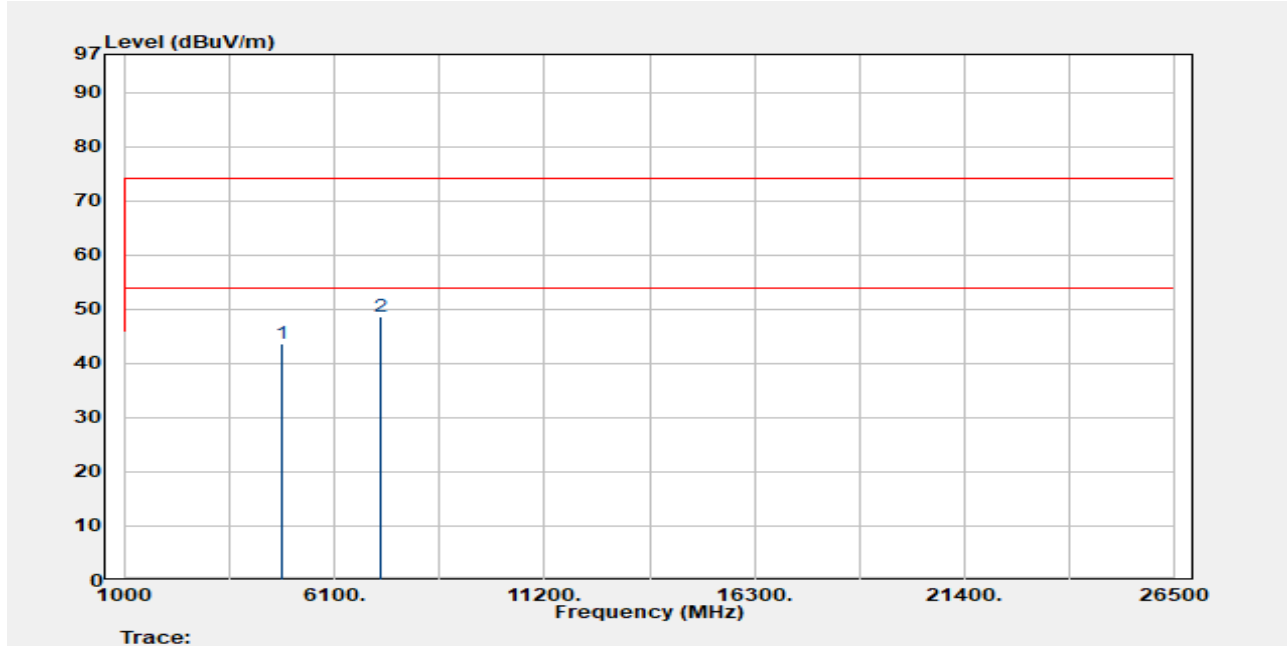

Freq. MHz	Detector Mode PK/QP/AV	Spectrum Reading Level dB $\mu$ V	Factor dB	Actual FS dB $\mu$ V/m	Limit @3m dB $\mu$ V/m	Margin dB
4804.00	Peak	41.73	1.87	43.60	74.00	-30.40
7206.00	Peak	41.27	7.47	48.74	74.00	-25.26

Freq. MHz	Detector Mode AV	Peak Actual FS (dB $\mu$ V/m)	Duty Cycle Factor (dB)	Average Value (dBuV/m)	Average Limit@3m (dBuV/m)	Margin (dB)
4804.000	Average	43.60	-24.93	18.67	54.00	-35.33
7206.000	Average	48.74	-24.93	23.81	54.00	-30.19

Unless otherwise stated the results shown in this test report refer only to the sample(s) tested and such sample(s) are retained for 90 days only.

除非另有說明，此報告結果僅對測試之樣品負責，同時此樣品僅保留90天。本報告未經本公司書面許可，不可部份複製。

This document is issued by the Company subject to its General Conditions of Service printed overleaf, available on request or accessible at <http://www.sgs.com.tw/Terms-and-Conditions> and for electronic format documents, subject to Terms and Conditions for Electronic Documents at <http://www.sgs.com.tw/Terms-and-Conditions>. Attention is drawn to the limitation of liability, indemnification and jurisdiction issues defined therein. Any holder of this document is advised that information contained hereon reflects the Company's findings at the time of its intervention only and within the limits of Client's instructions, if any. The Company's sole responsibility is to its Client and this document does not exonerate parties to a transaction from exercising all their rights and obligations under the transaction documents. This document cannot be reproduced except in full, without prior written approval of the Company. Any unauthorized alteration, forgery or falsification of the content or appearance of this document is unlawful and offenders may be prosecuted to the fullest extent of the law.

Report Number :TERF2309002194ER  
 Operation Mode :BR  
 Test Frequency :2441 MHz  
 Test Mode :Tx  
 EUT Pol :E2 Plane

Test Site :SAC 1  
 Test Date :2023-09-19  
 Temp./Humi. :24.0°C/62%  
 Antenna Pol. :Vertical  
 Engineer :Cooper Hsu

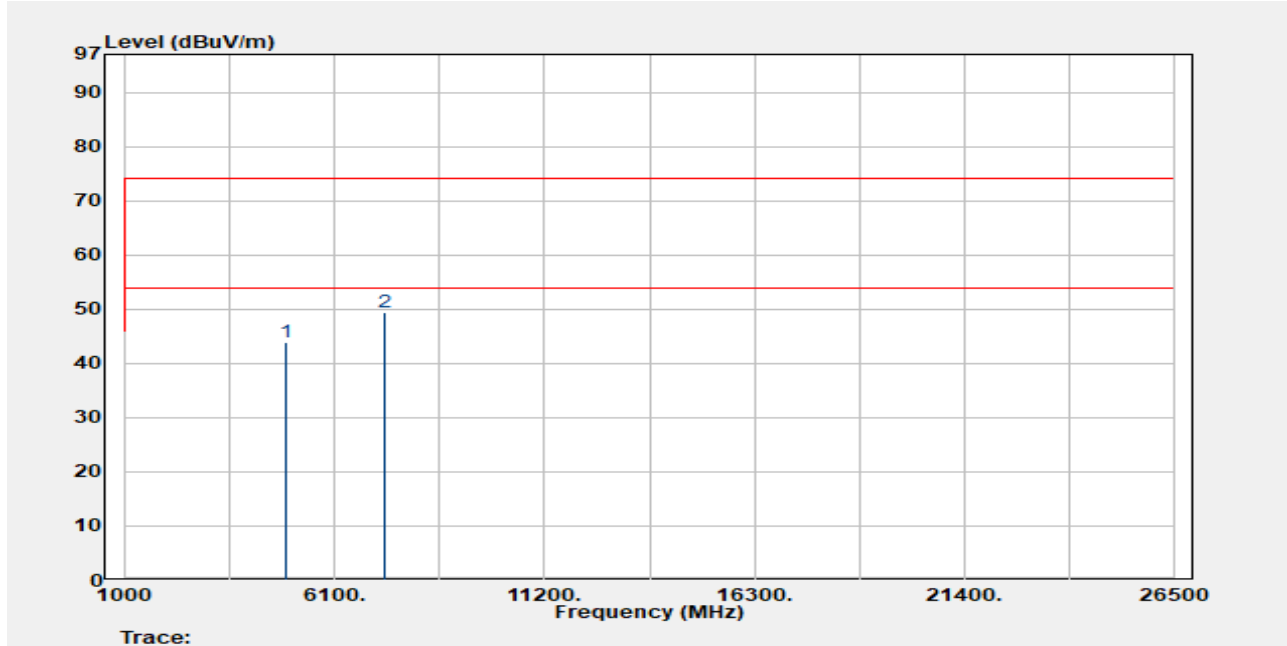

Freq. MHz	Detector Mode PK/QP/AV	Spectrum Reading Level d $\mu$ V	Factor dB	Actual FS d $\mu$ V/m	Limit @3m d $\mu$ V/m	Margin dB
4882.00	Peak	41.81	2.09	43.90	74.00	-30.10
7323.00	Peak	41.66	7.70	49.36	74.00	-24.64
Freq. MHz	Detector Mode AV	Peak Actual FS (d $\mu$ V/m)	Duty Cycle Factor (dB)	Average Value (d $\mu$ V/m)	Average Limit@3m (d $\mu$ V/m)	Margin (dB)

4882.000	Average	43.90	-24.93	18.97	54.00	-35.03
7323.000	Average	49.36	-24.93	24.43	54.00	-29.57

Unless otherwise stated the results shown in this test report refer only to the sample(s) tested and such sample(s) are retained for 90 days only.

除非另有說明，此報告結果僅對測試之樣品負責，同時此樣品僅保留90天。本報告未經本公司書面許可，不可部份複製。

This document is issued by the Company subject to its General Conditions of Service printed overleaf, available on request or accessible at <http://www.sgs.com.tw/Terms-and-Conditions> and for electronic format documents, subject to Terms and Conditions for Electronic Documents at <http://www.sgs.com.tw/Terms-and-Conditions>. Attention is drawn to the limitation of liability, indemnification and jurisdiction issues defined therein. Any holder of this document is advised that information contained hereon reflects the Company's findings at the time of its intervention only and within the limits of Client's instructions, if any. The Company's sole responsibility is to its Client and this document does not exonerate parties to a transaction from exercising all their rights and obligations under the transaction documents. This document cannot be reproduced except in full, without prior written approval of the Company. Any unauthorized alteration, forgery or falsification of the content or appearance of this document is unlawful and offenders may be prosecuted to the fullest extent of the law.

Report Number :TERF2309002194ER  
 Operation Mode :BR  
 Test Frequency :2441 MHz  
 Test Mode :Tx  
 EUT Pol :E2 Plane

Test Site :SAC 1  
 Test Date :2023-09-19  
 Temp./Humi. :24.0°C/62%  
 Antenna Pol. :Horizontal  
 Engineer :Cooper Hsu

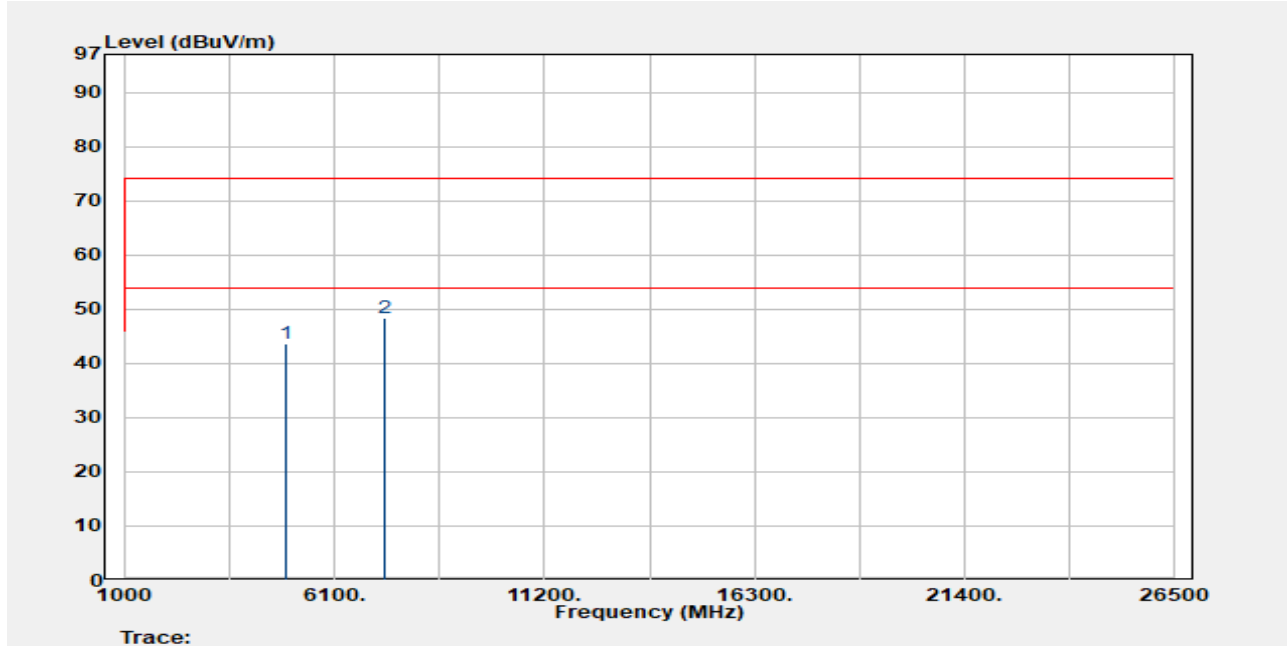

Freq. MHz	Detector Mode PK/QP/AV	Spectrum Reading Level dBµV	Factor dB	Actual FS dBµV/m	Limit @3m dBµV/m	Margin dB
4882.00	Peak	41.45	2.09	43.54	74.00	-30.46
7323.00	Peak	40.58	7.70	48.29	74.00	-25.71

Freq. MHz	Detector Mode AV	Peak Actual FS (dBµV/m)	Duty Cycle Factor (dB)	Average Value (dBuV/m)	Average Limit@3m (dBuV/m)	Margin (dB)
4882.000	Average	43.54	-24.93	18.61	54.00	-35.39
7323.000	Average	48.29	-24.93	23.36	54.00	-30.64

Unless otherwise stated the results shown in this test report refer only to the sample(s) tested and such sample(s) are retained for 90 days only.

除非另有說明，此報告結果僅對測試之樣品負責，同時此樣品僅保留90天。本報告未經本公司書面許可，不可部份複製。

This document is issued by the Company subject to its General Conditions of Service printed overleaf, available on request or accessible at <http://www.sgs.com.tw/Terms-and-Conditions> and for electronic format documents, subject to Terms and Conditions for Electronic Documents at <http://www.sgs.com.tw/Terms-and-Conditions>. Attention is drawn to the limitation of liability, indemnification and jurisdiction issues defined therein. Any holder of this document is advised that information contained hereon reflects the Company's findings at the time of its intervention only and within the limits of Client's instructions, if any. The Company's sole responsibility is to its Client and this document does not exonerate parties to a transaction from exercising all their rights and obligations under the transaction documents. This document cannot be reproduced except in full, without prior written approval of the Company. Any unauthorized alteration, forgery or falsification of the content or appearance of this document is unlawful and offenders may be prosecuted to the fullest extent of the law.

Report Number :TERF2309002194ER  
 Operation Mode :BR  
 Test Frequency :2480 MHz  
 Test Mode :Tx  
 EUT Pol :E2 Plane

Test Site :SAC 1  
 Test Date :2023-09-19  
 Temp./Humi. :24.0°C/62%  
 Antenna Pol. :Vertical  
 Engineer :Cooper Hsu

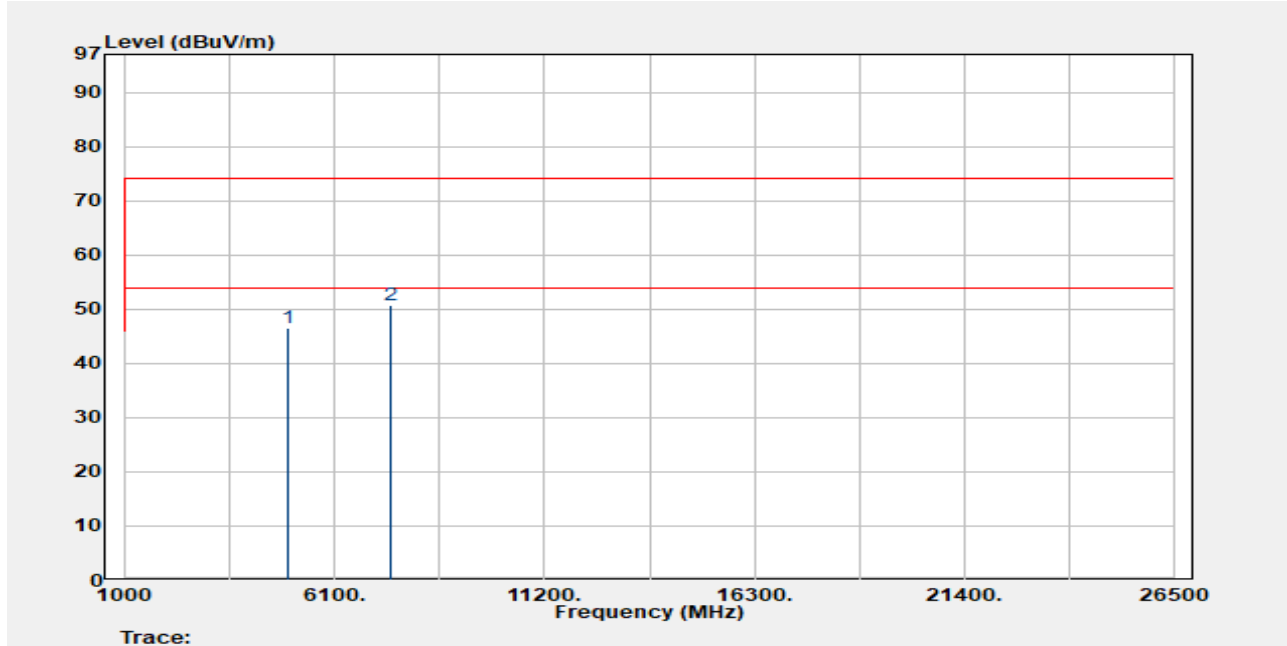

Freq. MHz	Detector Mode PK/QP/AV	Spectrum Reading Level dB $\mu$ V	Factor dB	Actual FS dB $\mu$ V/m	Limit @3m dB $\mu$ V/m	Margin dB
4960.00	Peak	44.32	2.33	46.65	74.00	-27.35
7440.00	Peak	43.00	7.79	50.79	74.00	-23.21
Freq. MHz	Detector Mode AV	Peak Actual FS (dB $\mu$ V/m)	Duty Cycle Factor (dB)	Average Value (dB $\mu$ V/m)	Average Limit@3m (dB $\mu$ V/m)	Margin (dB)
4960.000	Average	46.65	-24.93	21.72	54.00	-32.28
7440.000	Average	50.79	-24.93	25.86	54.00	-28.14

Unless otherwise stated the results shown in this test report refer only to the sample(s) tested and such sample(s) are retained for 90 days only.

除非另有說明，此報告結果僅對測試之樣品負責，同時此樣品僅保留90天。本報告未經本公司書面許可，不可部份複製。

This document is issued by the Company subject to its General Conditions of Service printed overleaf, available on request or accessible at <http://www.sgs.com.tw/Terms-and-Conditions> and for electronic format documents, subject to Terms and Conditions for Electronic Documents at <http://www.sgs.com.tw/Terms-and-Conditions>. Attention is drawn to the limitation of liability, indemnification and jurisdiction issues defined therein. Any holder of this document is advised that information contained hereon reflects the Company's findings at the time of its intervention only and within the limits of Client's instructions, if any. The Company's sole responsibility is to its Client and this document does not exonerate parties to a transaction from exercising all their rights and obligations under the transaction documents. This document cannot be reproduced except in full, without prior written approval of the Company. Any unauthorized alteration, forgery or falsification of the content or appearance of this document is unlawful and offenders may be prosecuted to the fullest extent of the law.

Report Number :TERF2309002194ER  
 Operation Mode :BR  
 Test Frequency :2480 MHz  
 Test Mode :Tx  
 EUT Pol :E2 Plane

Test Site :SAC 1  
 Test Date :2023-09-19  
 Temp./Humi. :24.0°C/62%  
 Antenna Pol. :Horizontal  
 Engineer :Cooper Hsu

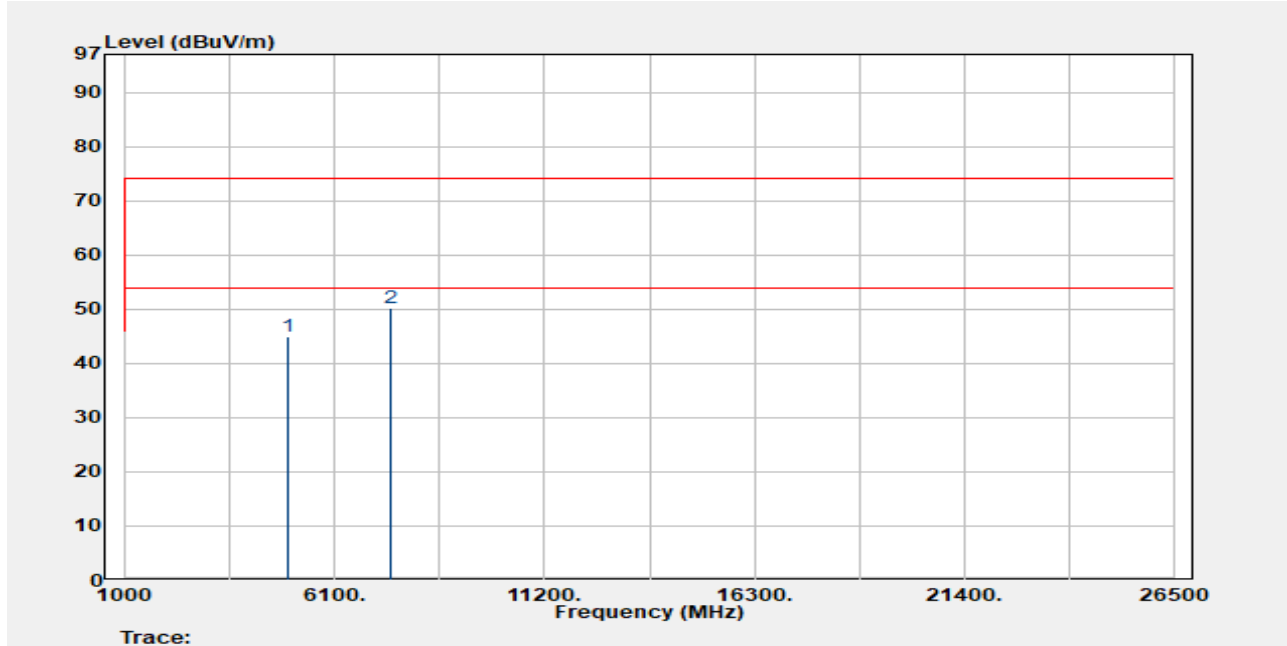

Freq. MHz	Detector Mode PK/QP/AV	Spectrum Reading Level d $\mu$ V	Factor dB	Actual FS d $\mu$ V/m	Limit @3m d $\mu$ V/m	Margin dB
4960.00	Peak	42.58	2.33	44.92	74.00	-29.08
7440.00	Peak	42.31	7.79	50.10	74.00	-23.90
Freq. MHz	Detector Mode AV	Peak Actual FS (d $\mu$ V/m)	Duty Cycle Factor (dB)	Average Value (d $\mu$ V/m)	Average Limit@3m (d $\mu$ V/m)	Margin (dB)
4960.000	Average	44.92	-24.93	19.99	54.00	-34.01
7440.000	Average	50.10	-24.93	25.17	54.00	-28.83

Unless otherwise stated the results shown in this test report refer only to the sample(s) tested and such sample(s) are retained for 90 days only.

除非另有說明，此報告結果僅對測試之樣品負責，同時此樣品僅保留90天。本報告未經本公司書面許可，不可部份複製。

This document is issued by the Company subject to its General Conditions of Service printed overleaf, available on request or accessible at <http://www.sgs.com.tw/Terms-and-Conditions> and for electronic format documents, subject to Terms and Conditions for Electronic Documents at <http://www.sgs.com.tw/Terms-and-Conditions>. Attention is drawn to the limitation of liability, indemnification and jurisdiction issues defined therein. Any holder of this document is advised that information contained hereon reflects the Company's findings at the time of its intervention only and within the limits of Client's instructions, if any. The Company's sole responsibility is to its Client and this document does not exonerate parties to a transaction from exercising all their rights and obligations under the transaction documents. This document cannot be reproduced except in full, without prior written approval of the Company. Any unauthorized alteration, forgery or falsification of the content or appearance of this document is unlawful and offenders may be prosecuted to the fullest extent of the law.

Report Number :TERF2309002194ER  
 Operation Mode :EDR 3M  
 Test Frequency :2402 MHz  
 Test Mode :Tx  
 EUT Pol :E2 Plane

Test Site :SAC 1  
 Test Date :2023-09-19  
 Temp./Humi. :24.0°C/62%  
 Antenna Pol. :Vertical  
 Engineer :Cooper Hsu

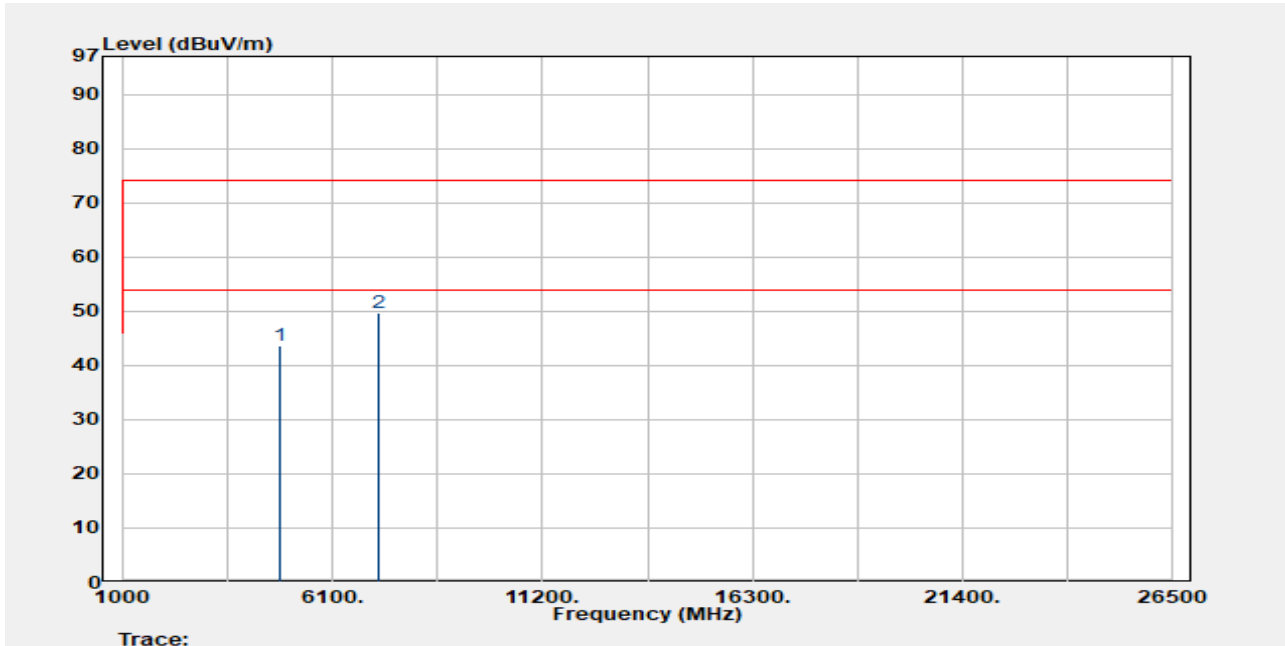

Freq. MHz	Detector Mode PK/QP/AV	Spectrum Reading Level dB $\mu$ V	Factor dB	Actual FS dB $\mu$ V/m	Limit @3m dB $\mu$ V/m	Margin dB
4804.00	Peak	41.79	1.87	43.67	74.00	-30.33
7206.00	Peak	42.18	7.47	49.65	74.00	-24.35

Freq. MHz	Detector Mode AV	Peak Actual FS (dB $\mu$ V/m)	Duty Cycle Factor (dB)	Average Value (dB $\mu$ V/m)	Average Limit@3m (dB $\mu$ V/m)	Margin (dB)
4804.000	Average	43.67	-25.46	18.21	54.00	-35.79
7206.000	Average	49.65	-25.46	24.19	54.00	-29.81

Unless otherwise stated the results shown in this test report refer only to the sample(s) tested and such sample(s) are retained for 90 days only.

除非另有說明，此報告結果僅對測試之樣品負責，同時此樣品僅保留90天。本報告未經本公司書面許可，不可部份複製。

This document is issued by the Company subject to its General Conditions of Service printed overleaf, available on request or accessible at <http://www.sgs.com.tw/Terms-and-Conditions> and for electronic format documents, subject to Terms and Conditions for Electronic Documents at <http://www.sgs.com.tw/Terms-and-Conditions>. Attention is drawn to the limitation of liability, indemnification and jurisdiction issues defined therein. Any holder of this document is advised that information contained hereon reflects the Company's findings at the time of its intervention only and within the limits of Client's instructions, if any. The Company's sole responsibility is to its Client and this document does not exonerate parties to a transaction from exercising all their rights and obligations under the transaction documents. This document cannot be reproduced except in full, without prior written approval of the Company. Any unauthorized alteration, forgery or falsification of the content or appearance of this document is unlawful and offenders may be prosecuted to the fullest extent of the law.

Report Number :TERF2309002194ER  
 Operation Mode :EDR 3M  
 Test Frequency :2402 MHz  
 Test Mode :Tx  
 EUT Pol :E2 Plane

Test Site :SAC 1  
 Test Date :2023-09-19  
 Temp./Humi. :24.0°C/62%  
 Antenna Pol. :Horizontal  
 Engineer :Cooper Hsu

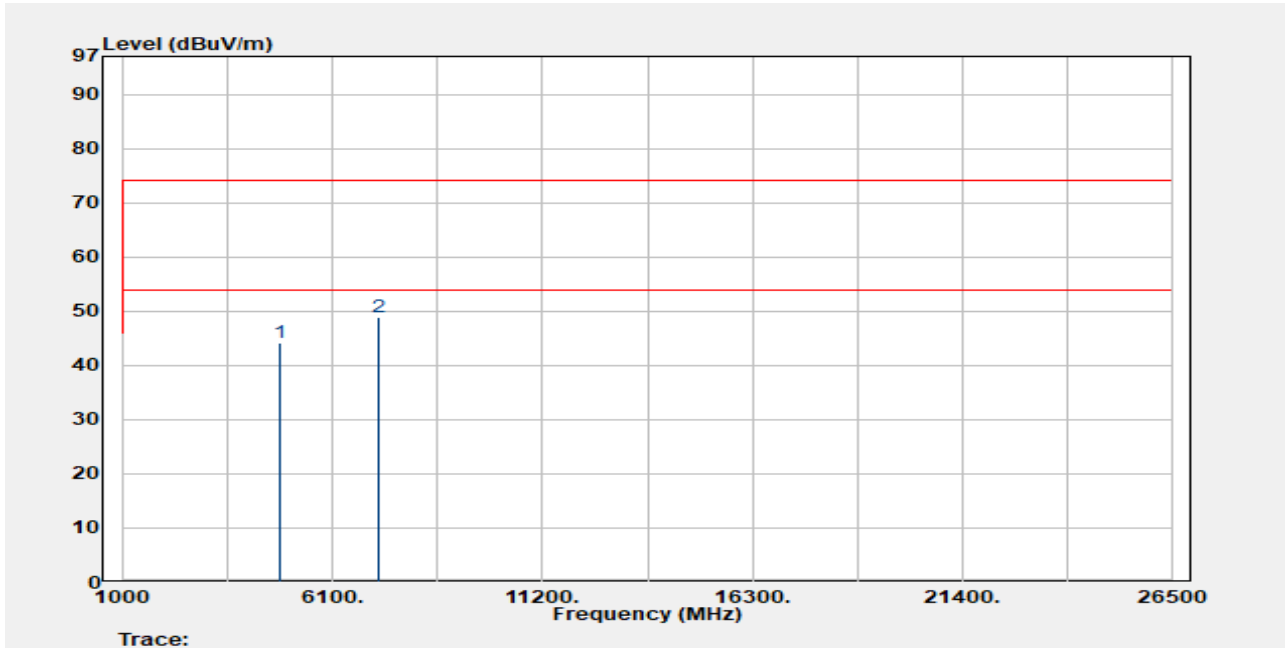

Freq. MHz	Detector Mode PK/QP/AV	Spectrum Reading Level dB $\mu$ V	Factor dB	Actual FS dB $\mu$ V/m	Limit @3m dB $\mu$ V/m	Margin dB
4804.00	Peak	42.40	1.87	44.27	74.00	-29.73
7206.00	Peak	41.55	7.47	49.02	74.00	-24.98

Freq. MHz	Detector Mode AV	Peak Actual FS (dB $\mu$ V/m)	Duty Cycle Factor (dB)	Average Value (dB $\mu$ V/m)	Average Limit@3m (dB $\mu$ V/m)	Margin (dB)
4804.000	Average	44.27	-25.46	18.81	54.00	-35.19
7206.000	Average	49.02	-25.46	23.56	54.00	-30.44

Unless otherwise stated the results shown in this test report refer only to the sample(s) tested and such sample(s) are retained for 90 days only.

除非另有說明，此報告結果僅對測試之樣品負責，同時此樣品僅保留90天。本報告未經本公司書面許可，不可部份複製。

This document is issued by the Company subject to its General Conditions of Service printed overleaf, available on request or accessible at <http://www.sgs.com.tw/Terms-and-Conditions> and for electronic format documents, subject to Terms and Conditions for Electronic Documents at <http://www.sgs.com.tw/Terms-and-Conditions>. Attention is drawn to the limitation of liability, indemnification and jurisdiction issues defined therein. Any holder of this document is advised that information contained hereon reflects the Company's findings at the time of its intervention only and within the limits of Client's instructions, if any. The Company's sole responsibility is to its Client and this document does not exonerate parties to a transaction from exercising all their rights and obligations under the transaction documents. This document cannot be reproduced except in full, without prior written approval of the Company. Any unauthorized alteration, forgery or falsification of the content or appearance of this document is unlawful and offenders may be prosecuted to the fullest extent of the law.



Report Number :TERF2309002194ER  
 Operation Mode :EDR 3M  
 Test Frequency :2441 MHz  
 Test Mode :Tx  
 EUT Pol :E2 Plane

Test Site :SAC 1  
 Test Date :2023-09-19  
 Temp./Humi. :24.0°C/62%  
 Antenna Pol. :Vertical  
 Engineer :Cooper Hsu

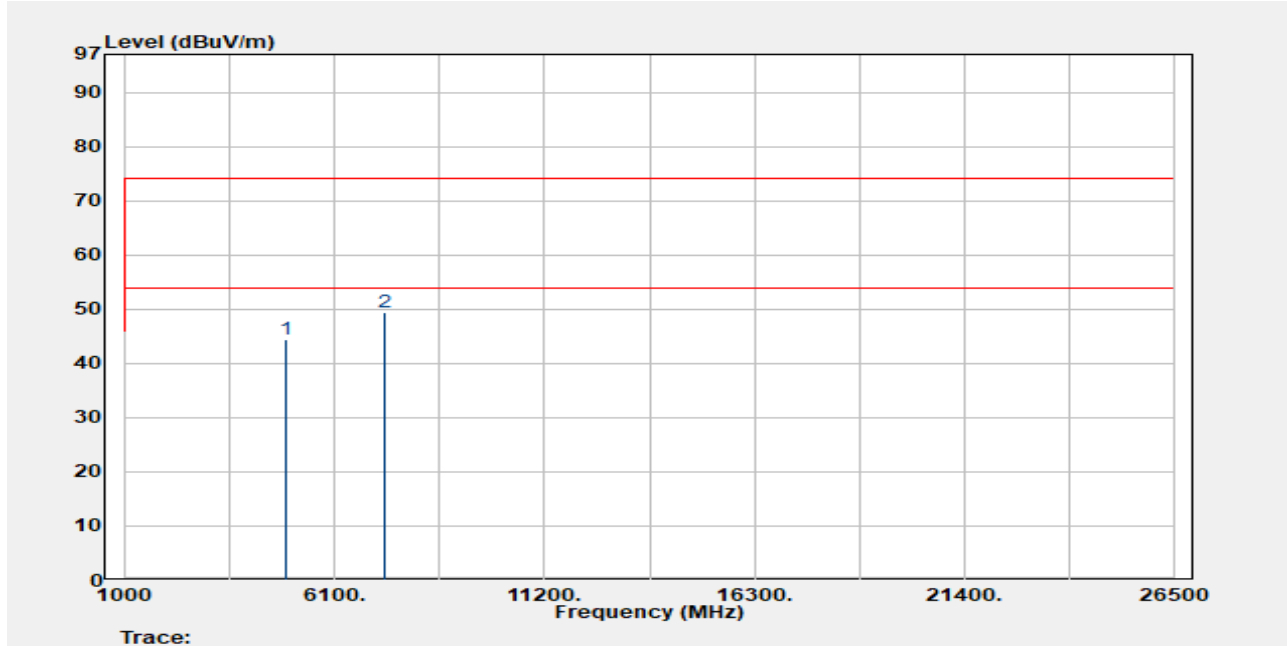

Freq. MHz	Detector Mode PK/QP/AV	Spectrum Reading Level d $\mu$ V	Factor dB	Actual FS d $\mu$ V/m	Limit @3m d $\mu$ V/m	Margin dB
4882.00	Peak	42.36	2.09	44.45	74.00	-29.55
7323.00	Peak	41.59	7.70	49.29	74.00	-24.71

Freq. MHz	Detector Mode AV	Peak Actual FS (d $\mu$ V/m)	Duty Cycle Factor (dB)	Average Value (d $\mu$ V/m)	Average Limit@3m (d $\mu$ V/m)	Margin (dB)
4882.000	Average	44.45	-25.46	18.99	54.00	-35.01
7323.000	Average	49.29	-25.46	23.83	54.00	-30.17

Unless otherwise stated the results shown in this test report refer only to the sample(s) tested and such sample(s) are retained for 90 days only.

除非另有說明，此報告結果僅對測試之樣品負責，同時此樣品僅保留90天。本報告未經本公司書面許可，不可部份複製。

This document is issued by the Company subject to its General Conditions of Service printed overleaf, available on request or accessible at <http://www.sgs.com.tw/Terms-and-Conditions> and for electronic format documents, subject to Terms and Conditions for Electronic Documents at <http://www.sgs.com.tw/Terms-and-Conditions>. Attention is drawn to the limitation of liability, indemnification and jurisdiction issues defined therein. Any holder of this document is advised that information contained hereon reflects the Company's findings at the time of its intervention only and within the limits of Client's instructions, if any. The Company's sole responsibility is to its Client and this document does not exonerate parties to a transaction from exercising all their rights and obligations under the transaction documents. This document cannot be reproduced except in full, without prior written approval of the Company. Any unauthorized alteration, forgery or falsification of the content or appearance of this document is unlawful and offenders may be prosecuted to the fullest extent of the law.

Report Number :TERF2309002194ER  
 Operation Mode :EDR 3M  
 Test Frequency :2441 MHz  
 Test Mode :Tx  
 EUT Pol :E2 Plane

Test Site :SAC 1  
 Test Date :2023-09-19  
 Temp./Humi. :24.0°C/62%  
 Antenna Pol. :Horizontal  
 Engineer :Cooper Hsu

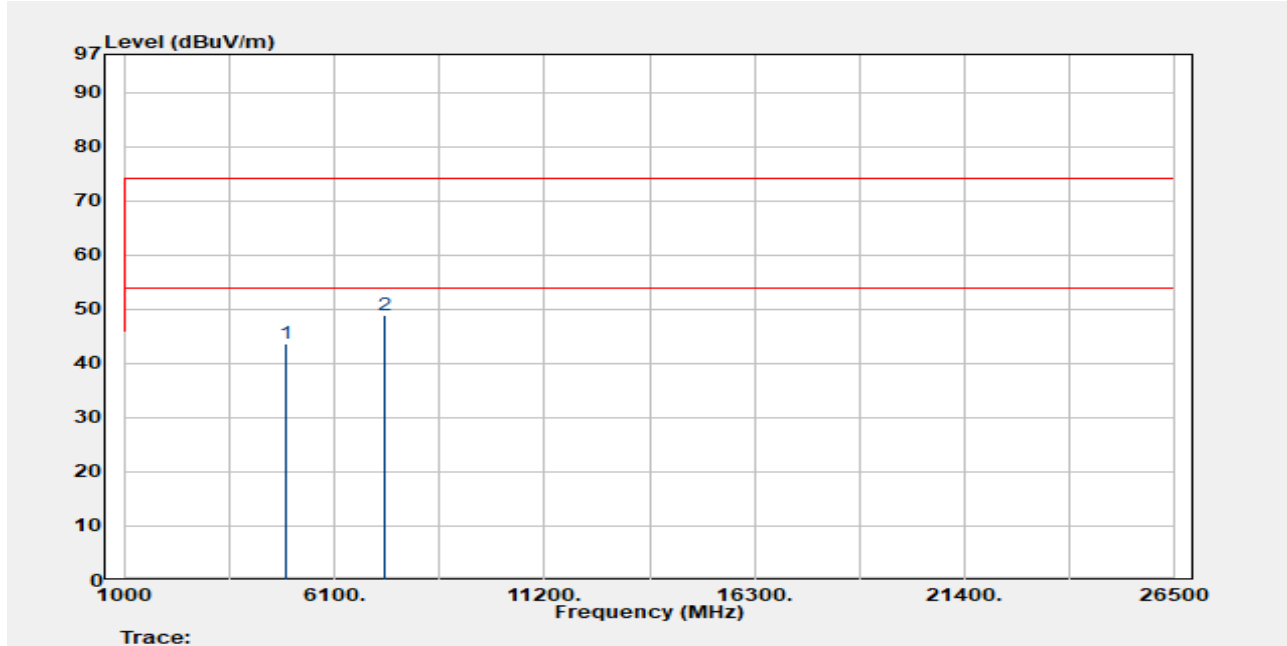

Freq. MHz	Detector Mode PK/QP/AV	Spectrum Reading Level dB $\mu$ V	Factor dB	Actual FS dB $\mu$ V/m	Limit @3m dB $\mu$ V/m	Margin dB
4882.00	Peak	41.52	2.09	43.61	74.00	-30.39
7323.00	Peak	41.07	7.70	48.77	74.00	-25.23

Freq. MHz	Detector Mode AV	Peak Actual FS (dB $\mu$ V/m)	Duty Cycle Factor (dB)	Average Value (dB $\mu$ V/m)	Average Limit@3m (dB $\mu$ V/m)	Margin (dB)
4882.000	Average	43.61	-25.46	18.15	54.00	-35.85
7323.000	Average	48.77	-25.46	23.31	54.00	-30.69

Unless otherwise stated the results shown in this test report refer only to the sample(s) tested and such sample(s) are retained for 90 days only.

除非另有說明，此報告結果僅對測試之樣品負責，同時此樣品僅保留90天。本報告未經本公司書面許可，不可部份複製。

This document is issued by the Company subject to its General Conditions of Service printed overleaf, available on request or accessible at <http://www.sgs.com.tw/Terms-and-Conditions> and for electronic format documents, subject to Terms and Conditions for Electronic Documents at <http://www.sgs.com.tw/Terms-and-Conditions>. Attention is drawn to the limitation of liability, indemnification and jurisdiction issues defined therein. Any holder of this document is advised that information contained hereon reflects the Company's findings at the time of its intervention only and within the limits of Client's instructions, if any. The Company's sole responsibility is to its Client and this document does not exonerate parties to a transaction from exercising all their rights and obligations under the transaction documents. This document cannot be reproduced except in full, without prior written approval of the Company. Any unauthorized alteration, forgery or falsification of the content or appearance of this document is unlawful and offenders may be prosecuted to the fullest extent of the law.

Report Number :TERF2309002194ER  
 Operation Mode :EDR 3M  
 Test Frequency :2480 MHz  
 Test Mode :Tx  
 EUT Pol :E2 Plane

Test Site :SAC 1  
 Test Date :2023-09-19  
 Temp./Humi. :24.0°C/62%  
 Antenna Pol. :Vertical  
 Engineer :Cooper Hsu

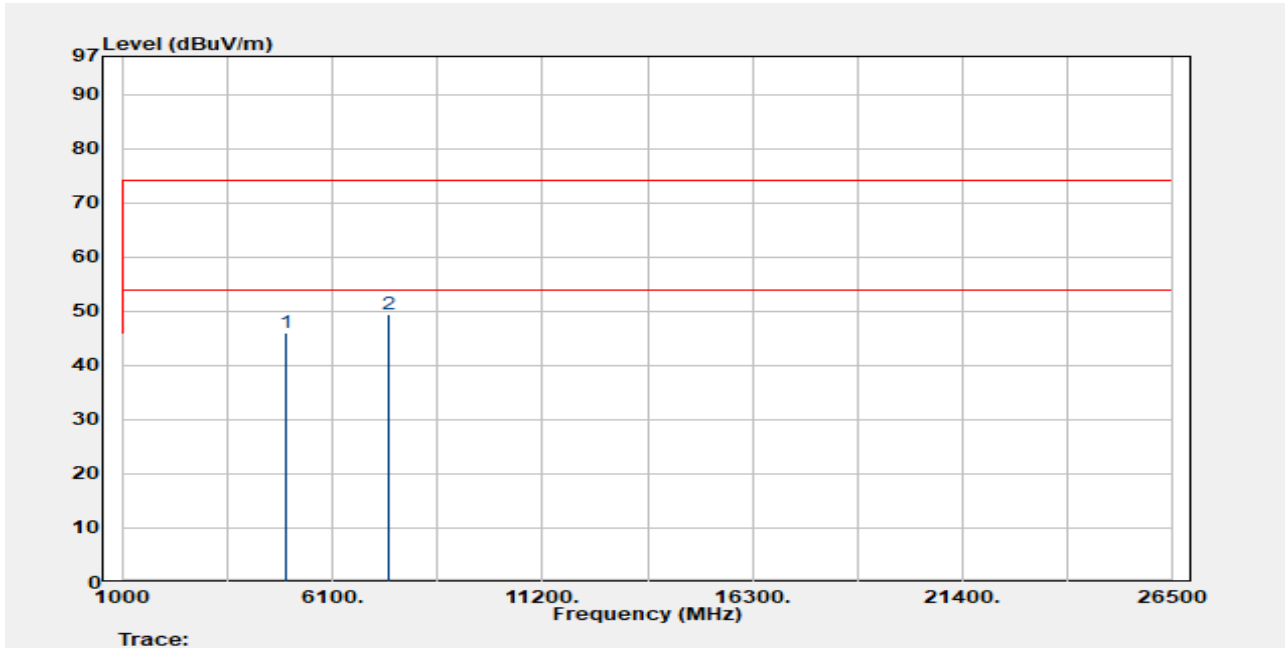

Freq. MHz	Detector Mode PK/QP/AV	Spectrum Reading Level dB $\mu$ V	Factor dB	Actual FS dB $\mu$ V/m	Limit @3m dB $\mu$ V/m	Margin dB
4960.00	Peak	43.64	2.33	45.97	74.00	-28.03
7440.00	Peak	41.59	7.79	49.38	74.00	-24.62

Freq. MHz	Detector Mode AV	Peak Actual FS (dB $\mu$ V/m)	Duty Cycle Factor (dB)	Average Value (dB $\mu$ V/m)	Average Limit@3m (dB $\mu$ V/m)	Margin (dB)
4960.000	Average	45.97	-25.46	20.51	54.00	-33.49
7440.000	Average	49.38	-25.46	23.92	54.00	-30.08

Unless otherwise stated the results shown in this test report refer only to the sample(s) tested and such sample(s) are retained for 90 days only.

除非另有說明，此報告結果僅對測試之樣品負責，同時此樣品僅保留90天。本報告未經本公司書面許可，不可部份複製。

This document is issued by the Company subject to its General Conditions of Service printed overleaf, available on request or accessible at <http://www.sgs.com.tw/Terms-and-Conditions> and for electronic format documents, subject to Terms and Conditions for Electronic Documents at <http://www.sgs.com.tw/Terms-and-Conditions>. Attention is drawn to the limitation of liability, indemnification and jurisdiction issues defined therein. Any holder of this document is advised that information contained hereon reflects the Company's findings at the time of its intervention only and within the limits of Client's instructions, if any. The Company's sole responsibility is to its Client and this document does not exonerate parties to a transaction from exercising all their rights and obligations under the transaction documents. This document cannot be reproduced except in full, without prior written approval of the Company. Any unauthorized alteration, forgery or falsification of the content or appearance of this document is unlawful and offenders may be prosecuted to the fullest extent of the law.

Report Number :TERF2309002194ER  
 Operation Mode :EDR 3M  
 Test Frequency :2480 MHz  
 Test Mode :Tx  
 EUT Pol :E2 Plane

Test Site :SAC 1  
 Test Date :2023-09-19  
 Temp./Humi. :24.0°C/62%  
 Antenna Pol. :Horizontal  
 Engineer :Cooper Hsu

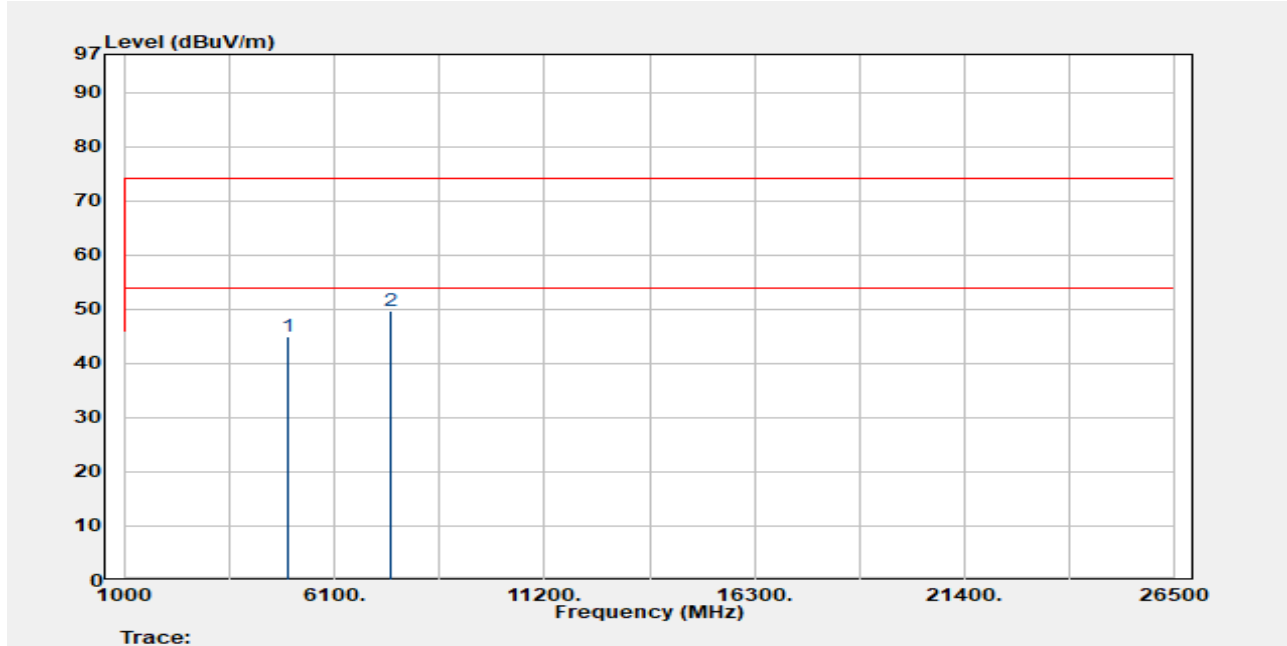

Freq. MHz	Detector Mode PK/QP/AV	Spectrum Reading Level dB $\mu$ V	Factor dB	Actual FS dB $\mu$ V/m	Limit @3m dB $\mu$ V/m	Margin dB
4960.00	Peak	42.69	2.33	45.02	74.00	-28.98
7440.00	Peak	41.93	7.79	49.72	74.00	-24.28

Freq. MHz	Detector Mode AV	Peak Actual FS (dB $\mu$ V/m)	Duty Cycle Factor (dB)	Average Value (dB $\mu$ V/m)	Average Limit@3m (dB $\mu$ V/m)	Margin (dB)
4960.000	Average	45.02	-25.46	19.56	54.00	-34.44
7440.000	Average	49.72	-25.46	24.26	54.00	-29.74

Unless otherwise stated the results shown in this test report refer only to the sample(s) tested and such sample(s) are retained for 90 days only.

除非另有說明，此報告結果僅對測試之樣品負責，同時此樣品僅保留90天。本報告未經本公司書面許可，不可部份複製。

This document is issued by the Company subject to its General Conditions of Service printed overleaf, available on request or accessible at <http://www.sgs.com.tw/Terms-and-Conditions> and for electronic format documents, subject to Terms and Conditions for Electronic Documents at <http://www.sgs.com.tw/Terms-and-Conditions>. Attention is drawn to the limitation of liability, indemnification and jurisdiction issues defined therein. Any holder of this document is advised that information contained hereon reflects the Company's findings at the time of its intervention only and within the limits of Client's instructions, if any. The Company's sole responsibility is to its Client and this document does not exonerate parties to a transaction from exercising all their rights and obligations under the transaction documents. This document cannot be reproduced except in full, without prior written approval of the Company. Any unauthorized alteration, forgery or falsification of the content or appearance of this document is unlawful and offenders may be prosecuted to the fullest extent of the law.

2<sup>nd</sup>

Report Number	:TERF2309002194ER	Test Site	:SAC 1
Operation Mode	:EDR 3M	Test Date	:2023-09-19
Test Frequency	:2441 MHz	Temp./Humi.	:24.0°C/62%
Test Mode	:Tx	Antenna Pol.	:Vertical
EUT Pol	:E2 Plane	Engineer	:Cooper Hsu

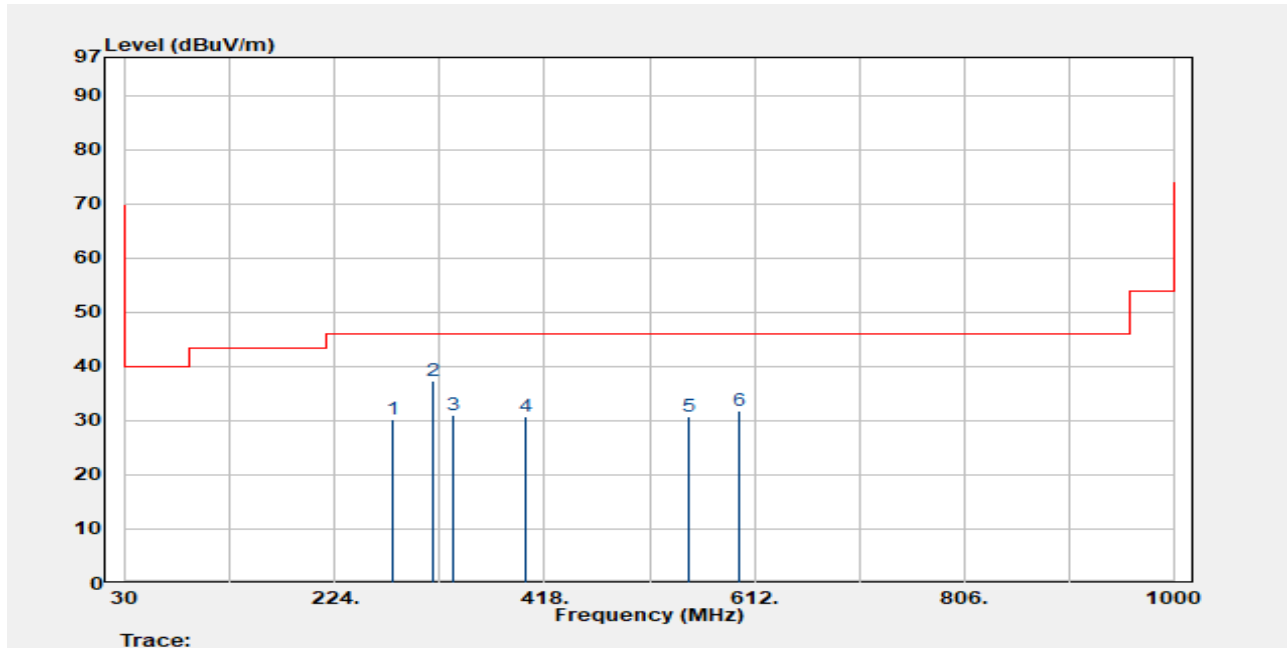

Freq. MHz	Detector Mode PK/QP/AV	Spectrum Reading Level dB $\mu$ V	Factor dB	Actual FS dB $\mu$ V/m	Limit @3m dB $\mu$ V/m	Margin dB
277.35	Peak	39.96	-9.65	30.32	46.00	-15.68
314.21	Peak	46.23	-9.03	37.20	46.00	-8.80
333.61	QP	39.61	-8.61	31.00	46.00	-15.00
399.57	Peak	37.69	-7.00	30.69	46.00	-15.31
551.86	Peak	34.99	-4.27	30.72	46.00	-15.28
598.42	QP	35.55	-3.87	31.68	46.00	-14.32

Unless otherwise stated the results shown in this test report refer only to the sample(s) tested and such sample(s) are retained for 90 days only.  
 除非另有說明，此報告結果僅對測試之樣品負責，同時此樣品僅保留90天。本報告未經本公司書面許可，不可部份複製。  
 This document is issued by the Company subject to its General Conditions of Service printed overleaf, available on request or accessible at <http://www.sgs.com.tw/Terms-and-Conditions> and for electronic format documents, subject to Terms and Conditions for Electronic Documents at <http://www.sgs.com.tw/Terms-and-Conditions>. Attention is drawn to the limitation of liability, indemnification and jurisdiction issues defined therein. Any holder of this document is advised that information contained hereon reflects the Company's findings at the time of its intervention only and within the limits of Client's instructions, if any. The Company's sole responsibility is to its Client and this document does not exonerate parties to a transaction from exercising all their rights and obligations under the transaction documents. This document cannot be reproduced except in full, without prior written approval of the Company. Any unauthorized alteration, forgery or falsification of the content or appearance of this document is unlawful and offenders may be prosecuted to the fullest extent of the law.

Report Number :TERF2309002194ER  
 Operation Mode :EDR 3M  
 Test Frequency :2441 MHz  
 Test Mode :Tx  
 EUT Pol :E2 Plane

Test Site :SAC 1  
 Test Date :2023-09-19  
 Temp./Humi. :24.0°C/62%  
 Antenna Pol. :Horizontal  
 Engineer :Cooper Hsu

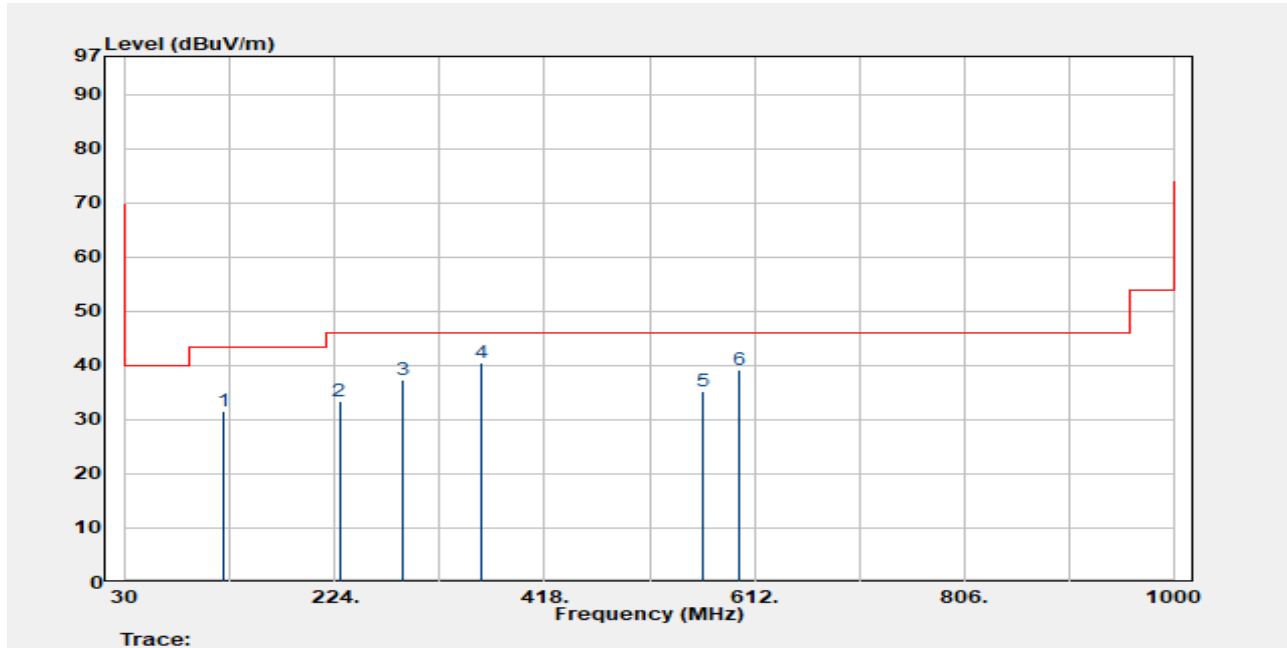

Freq. MHz	Detector Mode PK/QP/AV	Spectrum Reading Level dB $\mu$ V	Factor dB	Actual FS dB $\mu$ V/m	Limit @3m dB $\mu$ V/m	Margin dB
120.21	Peak	43.50	-11.89	31.61	43.50	-11.89
227.88	Peak	46.08	-12.81	33.26	46.00	-12.74
287.05	Peak	46.86	-9.56	37.30	46.00	-8.70
359.80	QP	48.12	-7.69	40.43	46.00	-5.57
564.47	Peak	39.50	-4.16	35.33	46.00	-10.67
598.42	Peak	42.94	-3.87	39.07	46.00	-6.93

Unless otherwise stated the results shown in this test report refer only to the sample(s) tested and such sample(s) are retained for 90 days only.

除非另有說明，此報告結果僅對測試之樣品負責，同時此樣品僅保留90天。本報告未經本公司書面許可，不可部份複製。

This document is issued by the Company subject to its General Conditions of Service printed overleaf, available on request or accessible at <http://www.sgs.com.tw/Terms-and-Conditions> and for electronic format documents, subject to Terms and Conditions for Electronic Documents at <http://www.sgs.com.tw/Terms-and-Conditions>. Attention is drawn to the limitation of liability, indemnification and jurisdiction issues defined therein. Any holder of this document is advised that information contained hereon reflects the Company's findings at the time of its intervention only and within the limits of Client's instructions, if any. The Company's sole responsibility is to its Client and this document does not exonerate parties to a transaction from exercising all their rights and obligations under the transaction documents. This document cannot be reproduced except in full, without prior written approval of the Company. Any unauthorized alteration, forgery or falsification of the content or appearance of this document is unlawful and offenders may be prosecuted to the fullest extent of the law.

Report Number :TERF2309002194ER  
 Operation Mode :BR  
 Test Frequency :2480 MHz  
 Test Mode :Tx  
 EUT Pol :E2 Plane

Test Site :SAC 1  
 Test Date :2023-09-19  
 Temp./Humi. :24.0°C/62%  
 Antenna Pol. :Vertical  
 Engineer :Cooper Hsu

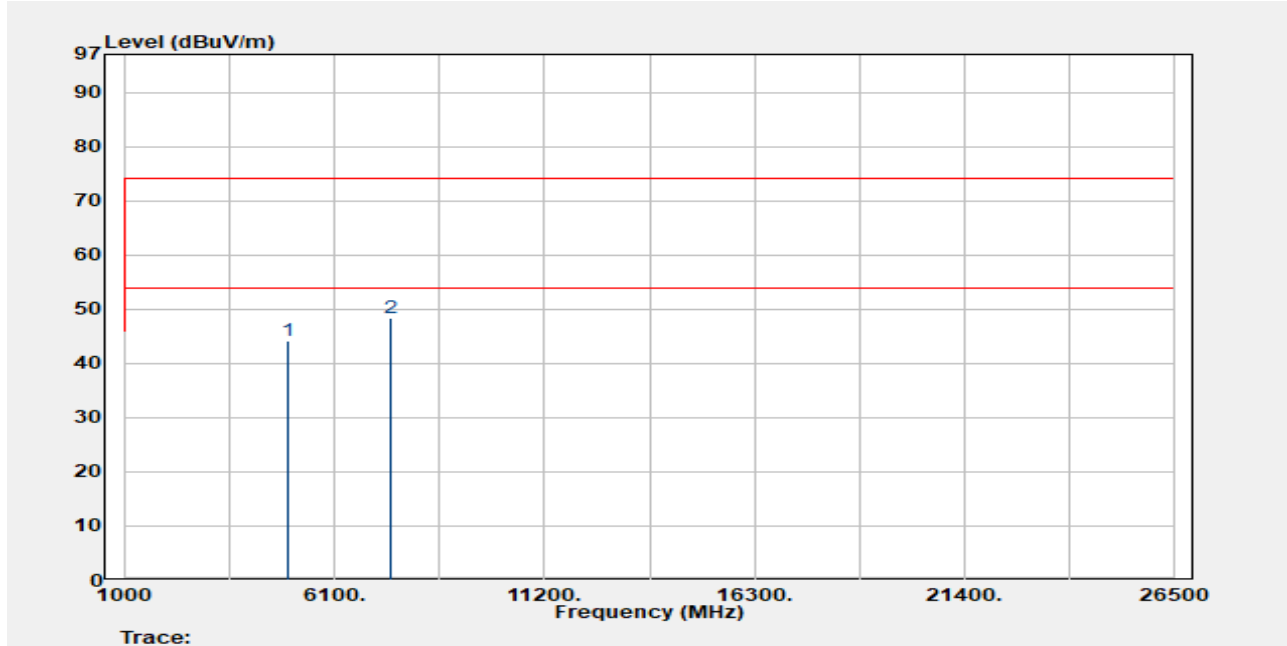

Freq. MHz	Detector Mode PK/QP/AV	Spectrum Reading Level dBµV	Factor dB	Actual FS dBµV/m	Limit @3m dBµV/m	Margin dB
4960.00	Peak	41.95	2.33	44.29	74.00	-29.71
7440.00	Peak	40.70	7.79	48.50	74.00	-25.50

Freq. MHz	Detector Mode AV	Peak Actual FS (dBµV/m)	Duty Cycle Factor (dB)	Average Value (dBuV/m)	Average Limit@3m (dBuV/m)	Margin (dB)
4960.000	Average	44.29	-24.73	19.56	54.00	-34.44
7440.000	Average	48.50	-24.73	23.77	54.00	-30.23

Unless otherwise stated the results shown in this test report refer only to the sample(s) tested and such sample(s) are retained for 90 days only.

除非另有說明，此報告結果僅對測試之樣品負責，同時此樣品僅保留90天。本報告未經本公司書面許可，不可部份複製。

This document is issued by the Company subject to its General Conditions of Service printed overleaf, available on request or accessible at <http://www.sgs.com.tw/Terms-and-Conditions> and for electronic format documents, subject to Terms and Conditions for Electronic Documents at <http://www.sgs.com.tw/Terms-and-Conditions>. Attention is drawn to the limitation of liability, indemnification and jurisdiction issues defined therein. Any holder of this document is advised that information contained hereon reflects the Company's findings at the time of its intervention only and within the limits of Client's instructions, if any. The Company's sole responsibility is to its Client and this document does not exonerate parties to a transaction from exercising all their rights and obligations under the transaction documents. This document cannot be reproduced except in full, without prior written approval of the Company. Any unauthorized alteration, forgery or falsification of the content or appearance of this document is unlawful and offenders may be prosecuted to the fullest extent of the law.

Report Number :TERF2309002194ER  
 Operation Mode :BR  
 Test Frequency :2480 MHz  
 Test Mode :Tx  
 EUT Pol :E2 Plane

Test Site :SAC 1  
 Test Date :2023-09-19  
 Temp./Humi. :24.0°C/62%  
 Antenna Pol. :Horizontal  
 Engineer :Cooper Hsu

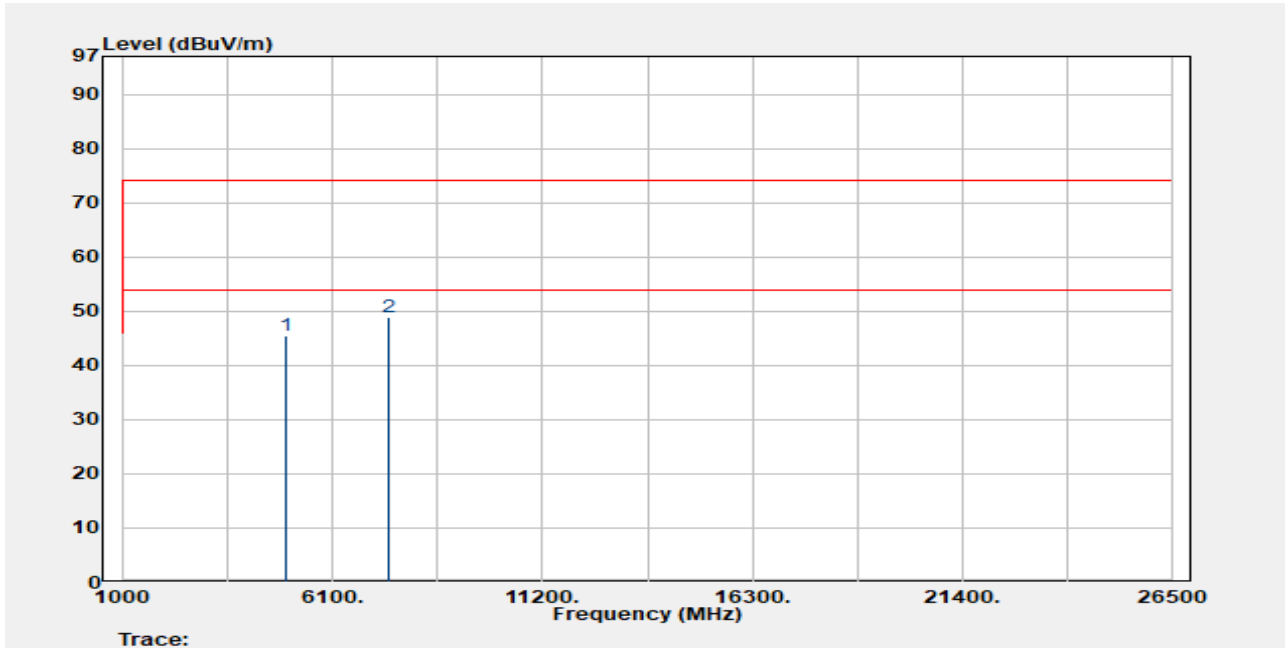

Freq. MHz	Detector Mode PK/QP/AV	Spectrum Reading Level d $\mu$ V	Factor dB	Actual FS d $\mu$ V/m	Limit @3m d $\mu$ V/m	Margin dB
4960.00	Peak	43.05	2.33	45.39	74.00	-28.61
7440.00	Peak	41.17	7.79	48.96	74.00	-25.04
Freq. MHz	Detector Mode AV	Peak Actual FS (d $\mu$ V/m)	Duty Cycle Factor (dB)	Average Value (d $\mu$ V/m)	Average Limit@3m (d $\mu$ V/m)	Margin (dB)
4960.000	Average	45.39	-24.73	20.66	54.00	-33.34
7440.000	Average	48.96	-24.73	24.23	54.00	-29.77

Unless otherwise stated the results shown in this test report refer only to the sample(s) tested and such sample(s) are retained for 90 days only.

除非另有說明，此報告結果僅對測試之樣品負責，同時此樣品僅保留90天。本報告未經本公司書面許可，不可部份複製。

This document is issued by the Company subject to its General Conditions of Service printed overleaf, available on request or accessible at <http://www.sgs.com.tw/Terms-and-Conditions> and for electronic format documents, subject to Terms and Conditions for Electronic Documents at <http://www.sgs.com.tw/Terms-and-Conditions>. Attention is drawn to the limitation of liability, indemnification and jurisdiction issues defined therein. Any holder of this document is advised that information contained hereon reflects the Company's findings at the time of its intervention only and within the limits of Client's instructions, if any. The Company's sole responsibility is to its Client and this document does not exonerate parties to a transaction from exercising all their rights and obligations under the transaction documents. This document cannot be reproduced except in full, without prior written approval of the Company. Any unauthorized alteration, forgery or falsification of the content or appearance of this document is unlawful and offenders may be prosecuted to the fullest extent of the law.



Report Number :TERF2309002194ER  
 Operation Mode :EDR 3M  
 Test Frequency :2480 MHz  
 Test Mode :Tx  
 EUT Pol :E2 Plane

Test Site :SAC 1  
 Test Date :2023-09-19  
 Temp./Humi. :24.0°C/62%  
 Antenna Pol. :Vertical  
 Engineer :Cooper Hsu

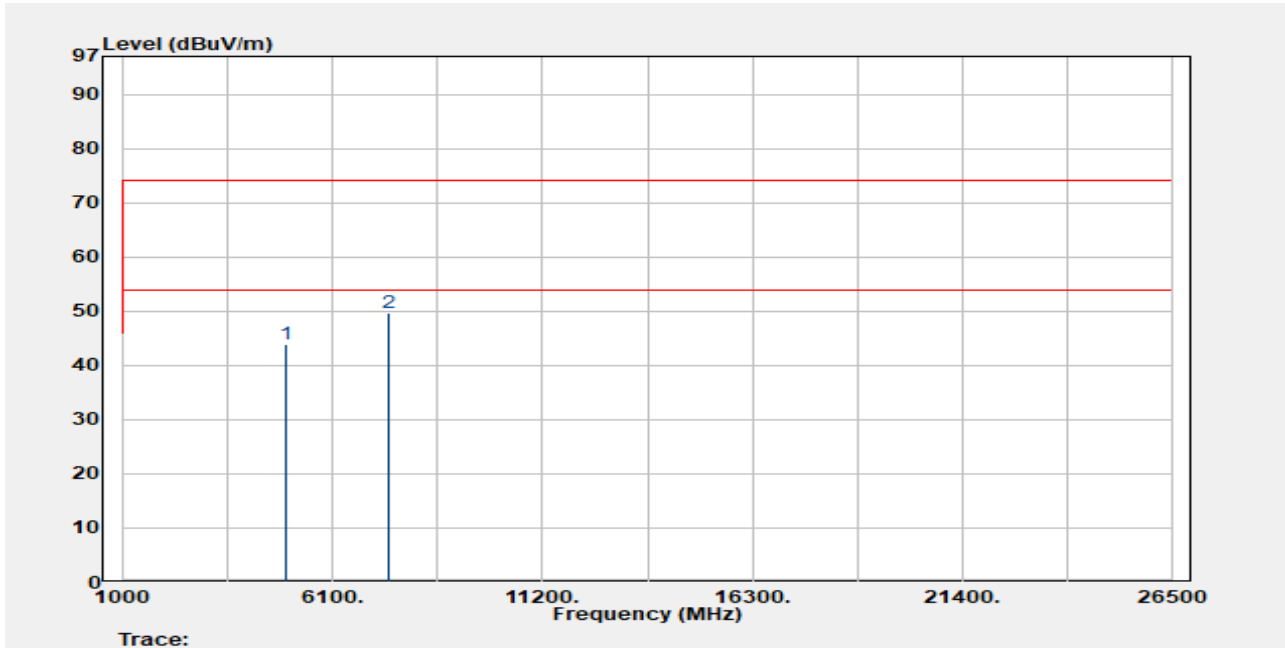

Freq. MHz	Detector Mode PK/QP/AV	Spectrum Reading Level dB $\mu$ V	Factor dB	Actual FS dB $\mu$ V/m	Limit @3m dB $\mu$ V/m	Margin dB
4960.00	Peak	41.65	2.33	43.99	74.00	-30.01
7440.00	Peak	41.90	7.79	49.69	74.00	-24.31
Freq. MHz	Detector Mode AV	Peak Actual FS (dB $\mu$ V/m)	Duty Cycle Factor (dB)	Average Value (dBuV/m)	Average Limit@3m (dBuV/m)	Margin (dB)
4960.000	Average	43.99	-25.04	18.95	54.00	-35.05
7440.000	Average	49.69	-25.04	24.65	54.00	-29.35

Unless otherwise stated the results shown in this test report refer only to the sample(s) tested and such sample(s) are retained for 90 days only.

除非另有說明，此報告結果僅對測試之樣品負責，同時此樣品僅保留90天。本報告未經本公司書面許可，不可部份複製。

This document is issued by the Company subject to its General Conditions of Service printed overleaf, available on request or accessible at <http://www.sgs.com.tw/Terms-and-Conditions> and for electronic format documents, subject to Terms and Conditions for Electronic Documents at <http://www.sgs.com.tw/Terms-and-Conditions>. Attention is drawn to the limitation of liability, indemnification and jurisdiction issues defined therein. Any holder of this document is advised that information contained hereon reflects the Company's findings at the time of its intervention only and within the limits of Client's instructions, if any. The Company's sole responsibility is to its Client and this document does not exonerate parties to a transaction from exercising all their rights and obligations under the transaction documents. This document cannot be reproduced except in full, without prior written approval of the Company. Any unauthorized alteration, forgery or falsification of the content or appearance of this document is unlawful and offenders may be prosecuted to the fullest extent of the law.

Report Number :TERF2309002194ER  
 Operation Mode :EDR 3M  
 Test Frequency :2480 MHz  
 Test Mode :Tx  
 EUT Pol :E2 Plane

Test Site :SAC 1  
 Test Date :2023-09-19  
 Temp./Humi. :24.0°C/62%  
 Antenna Pol. :Horizontal  
 Engineer :Cooper Hsu

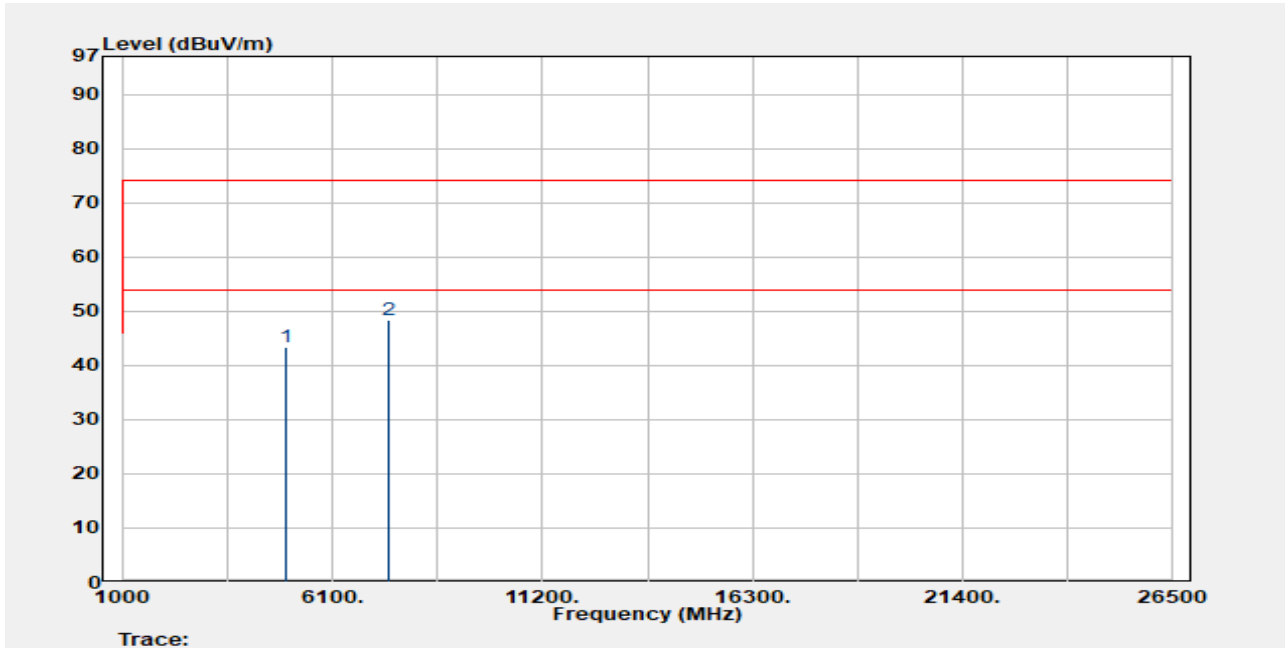

Freq. MHz	Detector Mode PK/QP/AV	Spectrum Reading Level dB $\mu$ V	Factor dB	Actual FS dB $\mu$ V/m	Limit @3m dB $\mu$ V/m	Margin dB
4960.00	Peak	41.16	2.33	43.50	74.00	-30.50
7440.00	Peak	40.53	7.79	48.32	74.00	-25.68
Freq. MHz	Detector Mode AV	Peak Actual FS (dB $\mu$ V/m)	Duty Cycle Factor (dB)	Average Value (dBuV/m)	Average Limit@3m (dBuV/m)	Margin (dB)
4960.000	Average	43.50	-25.04	18.46	54.00	-35.54
7440.000	Average	48.32	-25.04	23.28	54.00	-30.72

Unless otherwise stated the results shown in this test report refer only to the sample(s) tested and such sample(s) are retained for 90 days only.

除非另有說明，此報告結果僅對測試之樣品負責，同時此樣品僅保留90天。本報告未經本公司書面許可，不可部份複製。

This document is issued by the Company subject to its General Conditions of Service printed overleaf, available on request or accessible at <http://www.sgs.com.tw/Terms-and-Conditions> and for electronic format documents, subject to Terms and Conditions for Electronic Documents at <http://www.sgs.com.tw/Terms-and-Conditions>. Attention is drawn to the limitation of liability, indemnification and jurisdiction issues defined therein. Any holder of this document is advised that information contained hereon reflects the Company's findings at the time of its intervention only and within the limits of Client's instructions, if any. The Company's sole responsibility is to its Client and this document does not exonerate parties to a transaction from exercising all their rights and obligations under the transaction documents. This document cannot be reproduced except in full, without prior written approval of the Company. Any unauthorized alteration, forgery or falsification of the content or appearance of this document is unlawful and offenders may be prosecuted to the fullest extent of the law.

## 12 FREQUENCY SEPARATION

### 12.1 Standard Applicable

Frequency hopping systems shall have hopping channel carrier frequencies separated by minimum of 25 kHz or the  $\frac{2}{3} \times 20\text{dB}$  bandwidth of the hopping channel, whichever is greater.

### 12.2 Test Setup

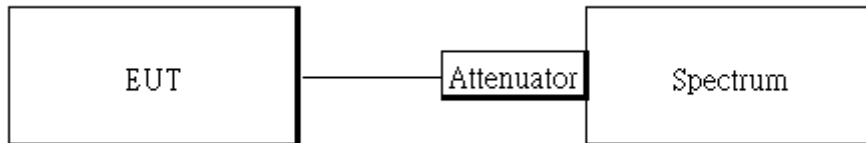

### 12.3 Measurement Procedure

1. Place the EUT on the table and set it in transmitting mode.
2. The testing follows ANSI C63.10:2013.
3. Remove the antenna from the EUT and then connect a low loss RF cable from the antenna port to the spectrum analyzer.
4. Set center frequency of spectrum analyzer = middle of hopping channel.
5. Set the RBW approximately 30% of the channel spacing,  $\text{VBW} \geq \text{RBW}$ .
6. Adjust Span to Wide enough to capture the peaks of two adjacent channels.
7. Sweep = auto.
8. Max hold. Mark 3 Peaks of hopping channel and record the 3 peaks frequency.

### 12.4 Measurement Result

Channel separation (MHz)	Limit	Result
1	$\geq 25 \text{ kHz}$ or $\frac{2}{3}$ times 20dB bandwidth	PASS

Unless otherwise stated the results shown in this test report refer only to the sample(s) tested and such sample(s) are retained for 90 days only.

除非另有說明，此報告結果僅對測試之樣品負責，同時此樣品僅保留90天。本報告未經本公司書面許可，不可部份複製。

This document is issued by the Company subject to its General Conditions of Service printed overleaf, available on request or accessible at <http://www.sgs.com.tw/Terms-and-Conditions> and for electronic format documents, subject to Terms and Conditions for Electronic Documents at <http://www.sgs.com.tw/Terms-and-Conditions>. Attention is drawn to the limitation of liability, indemnification and jurisdiction issues defined therein. Any holder of this document is advised that information contained hereon reflects the Company's findings at the time of its intervention only and within the limits of Client's instructions, if any. The Company's sole responsibility is to its Client and this document does not exonerate parties to a transaction from exercising all their rights and obligations under the transaction documents. This document cannot be reproduced except in full, without prior written approval of the Company. Any unauthorized alteration, forgery or falsification of the content or appearance of this document is unlawful and offenders may be prosecuted to the fullest extent of the law.

GFSK\_1M\_DH5\_CH0CH1CH2



π/4DQPSK\_2M\_DH5\_CH0CH1CH2



GFSK\_1M\_DH5\_CH38CH39CH40

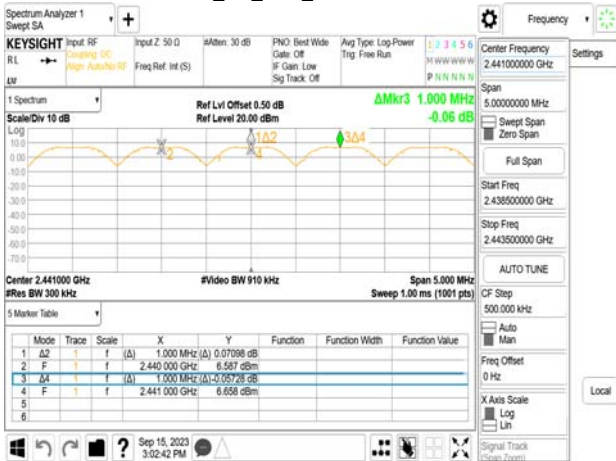

π/4DQPSK\_2M\_DH5\_CH38CH39CH40

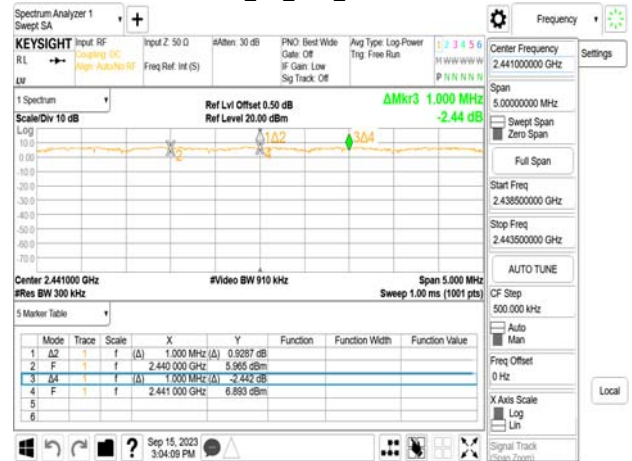

GFSK\_1M\_DH5\_CH76CH77CH78



π/4DQPSK\_2M\_DH5\_CH76CH77CH78



Unless otherwise stated the results shown in this test report refer only to the sample(s) tested and such sample(s) are retained for 90 days only.

除非另有說明，此報告結果僅對測試之樣品負責，同時此樣品僅保留90天。本報告未經本公司書面許可，不可部份複製。

This document is issued by the Company subject to its General Conditions of Service printed overleaf, available on request or accessible at <http://www.sgs.com.tw/Terms-and-Conditions> and for electronic format documents, subject to Terms and Conditions for Electronic Documents at <http://www.sgs.com.tw/Terms-and-Conditions>. Attention is drawn to the limitation of liability, indemnification and jurisdiction issues defined therein. Any holder of this document is advised that information contained hereon reflects the Company's findings at the time of its intervention only and within the limits of Client's instructions, if any. The Company's sole responsibility is to its Client and this document does not exonerate parties to a transaction from exercising all their rights and obligations under the transaction documents. This document cannot be reproduced except in full, without prior written approval of the Company. Any unauthorized alteration, forgery or falsification of the content or appearance of this document is unlawful and offenders may be prosecuted to the fullest extent of the law.

### 8DPSK\_3M\_DH5\_CH0CH1CH2



### 8DPSK\_3M\_DH5\_CH38CH39CH40



### 8DPSK\_3M\_DH5\_CH76CH77CH78



Unless otherwise stated the results shown in this test report refer only to the sample(s) tested and such sample(s) are retained for 90 days only.

除非另有說明，此報告結果僅對測試之樣品負責，同時此樣品僅保留90天。本報告未經本公司書面許可，不可部份複製。

This document is issued by the Company subject to its General Conditions of Service printed overleaf, available on request or accessible at <http://www.sgs.com.tw/Terms-and-Conditions>, and for electronic format documents, subject to Terms and Conditions for Electronic Documents at <http://www.sgs.com.tw/Terms-and-Conditions>. Attention is drawn to the limitation of liability, indemnification and jurisdiction issues defined therein. Any holder of this document is advised that information contained hereon reflects the Company's findings at the time of its intervention only and within the limits of Client's instructions, if any. The Company's sole responsibility is to its Client and this document does not exonerate parties to a transaction from exercising all their rights and obligations under the transaction documents. This document cannot be reproduced except in full, without prior written approval of the Company. Any unauthorized alteration, forgery or falsification of the content or appearance of this document is unlawful and offenders may be prosecuted to the fullest extent of the law.

## 13 NUMBER OF HOPPING FREQUENCY

### 13.1 Standard Applicable

Frequency hopping systems operating in the 2400MHz-2483.5 MHz bands shall use at least 15 hopping frequencies.

### 13.2 Test Setup

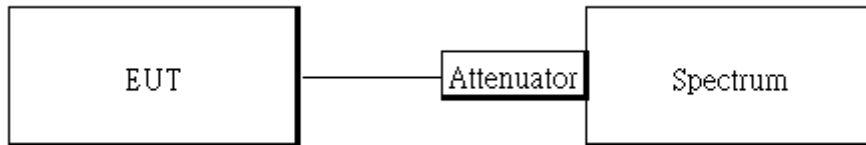

### 13.3 Measurement Procedure

1. Place the EUT on the table and set it in transmitting mode.
2. The testing follows ANSI C63.10:2013.
3. Remove the antenna from the EUT and then connect a low loss RF cable from the antenna port to the spectrum analyzer.
4. Set spectrum analyzer Start=2400MHz, Stop = 2483.5MHz, Sweep = auto.
5. Set the spectrum analyzer as RBW = 30% of the channel spacing, VBW ≥ RBW., Detector = Peak
6. Max hold, view and count how many channel in the band.

### 13.4 Measurement Result

#### Tabular Data of Total Channel Number

	<i>Channel Number</i>	<i>Limit</i>
<b>2.4 GHz – 2.441 GHz</b>	<b>40</b>	<b>&gt;15</b>
<b>2.441 GHz – 2.4835 GHz</b>	<b>39</b>	
<b>2.4 GHz ~2.4835 GHz</b>	<b>(40+39) = 79</b>	

Unless otherwise stated the results shown in this test report refer only to the sample(s) tested and such sample(s) are retained for 90 days only.

除非另有說明，此報告結果僅對測試之樣品負責，同時此樣品僅保留90天。本報告未經本公司書面許可，不可部份複製。  
 This document is issued by the Company subject to its General Conditions of Service printed overleaf, available on request or accessible at <http://www.sgs.com.tw/Terms-and-Conditions> and for electronic format documents, subject to Terms and Conditions for Electronic Documents at <http://www.sgs.com.tw/Terms-and-Conditions>. Attention is drawn to the limitation of liability, indemnification and jurisdiction issues defined therein. Any holder of this document is advised that information contained hereon reflects the Company's findings at the time of its intervention only and within the limits of Client's instructions, if any. The Company's sole responsibility is to its Client and this document does not exonerate parties to a transaction from exercising all their rights and obligations under the transaction documents. This document cannot be reproduced except in full, without prior written approval of the Company. Any unauthorized alteration, forgery or falsification of the content or appearance of this document is unlawful and offenders may be prosecuted to the fullest extent of the law.

GFSK\_1M\_DH5\_2400-2441

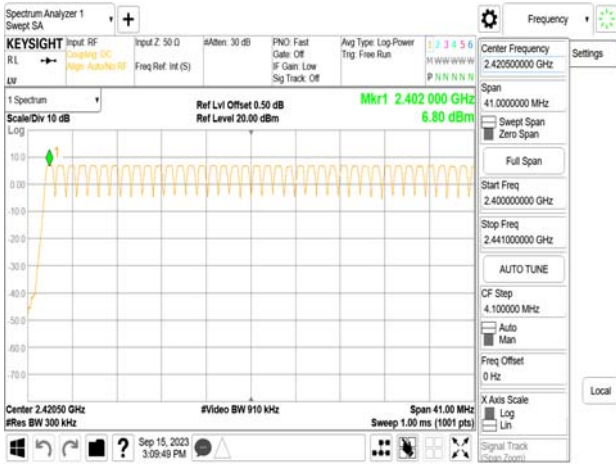

8DPSK\_3M\_DH5\_2400-2441

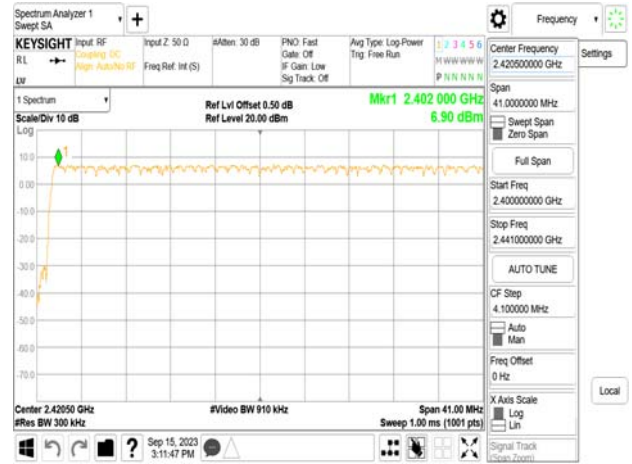

GFSK\_1M\_DH5\_2441-2480

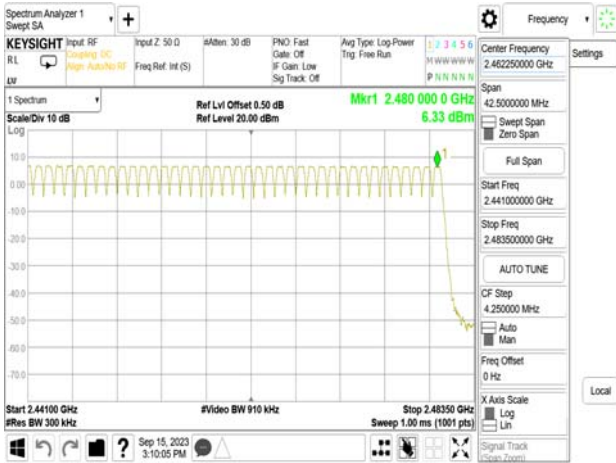

8DPSK\_3M\_DH5\_2441-2480

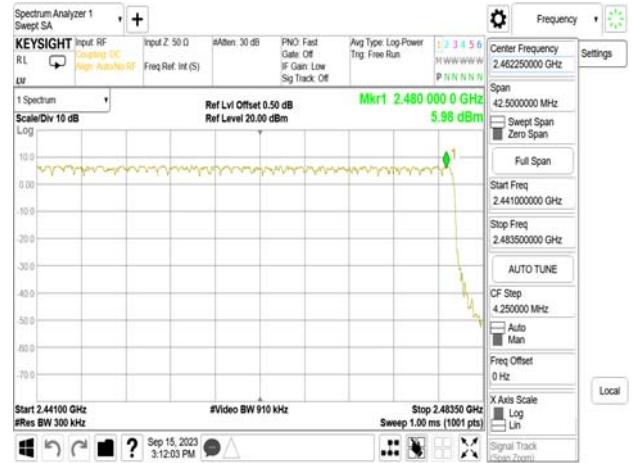

Unless otherwise stated the results shown in this test report refer only to the sample(s) tested and such sample(s) are retained for 90 days only.

除非另有說明，此報告結果僅對測試之樣品負責，同時此樣品僅保留90天。本報告未經本公司書面許可，不可部份複製。

This document is issued by the Company subject to its General Conditions of Service printed overleaf, available on request or accessible at <http://www.sgs.com.tw/Terms-and-Conditions>, and for electronic format documents, subject to Terms and Conditions for Electronic Documents at <http://www.sgs.com.tw/Terms-and-Conditions>. Attention is drawn to the limitation of liability, indemnification and jurisdiction issues defined therein. Any holder of this document is advised that information contained hereon reflects the Company's findings at the time of its intervention only and within the limits of Client's instructions, if any. The Company's sole responsibility is to its Client and this document does not exonerate parties to a transaction from exercising all their rights and obligations under the transaction documents. This document cannot be reproduced except in full, without prior written approval of the Company. Any unauthorized alteration, forgery or falsification of the content or appearance of this document is unlawful and offenders may be prosecuted to the fullest extent of the law.

## 14 TIME OF OCCUPANCY (DWELL TIME)

### 14.1 Standard Applicable

Frequency hopping systems operating in the 2400MHz-2483.5MHz. The average time of occupancy on any frequency shall not greater than 0.4 s within period of 0.4 seconds multiplied by the number of hopping channel employed.

### 14.2 Test Setup

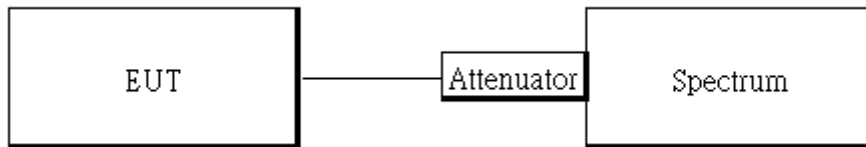

### 14.3 Measurement Procedure

1. Place the EUT on the table and set it in transmitting mode.
2. The testing follows ANSI C63.10:2013.
3. Remove the antenna from the EUT and then connect a low loss RF cable from the antenna port to the spectrum analyzer.
4. Set center frequency of spectrum analyzer = operating frequency.
5. Set the spectrum analyzer as RBW, VBW=1MHz, 3MHz, Span = 0Hz , Detector = Peak, Adjust Sweep = 2~8ms.
6. Repeat above procedures until all frequency of the interest measured were complete.

Formula Deduced: time occupancy of one time slot X Hopping rate / total slot in one channel / total channel that hops X period of working channels.

Where, standard hopping rate is 1600 hops/s, slot in one channel for DH1, DH3, and DH5 is 2, 4, and 6, respectively.

DH1 consists of single time slot of the uplink, and one slot of the downlink Total Slot: 2

DH3 consists of three time slot of the uplink, and one slot of the downlink. Total Slot: 4

DH5 consists of five time slot of the uplink, and one slot of the downlink. Total Slot: 6

Note: the result of the complete test default channel at 1Mbps is recorded on the test report, 2Mbps, and 3Mbps only records the measurement result at middle channel that reveals no much deviation.

Unless otherwise stated the results shown in this test report refer only to the sample(s) tested and such sample(s) are retained for 90 days only.

除非另有說明，此報告結果僅對測試之樣品負責，同時此樣品僅保留90天。本報告未經本公司書面許可，不可部份複製。

This document is issued by the Company subject to its General Conditions of Service printed overleaf, available on request or accessible at <http://www.sgs.com.tw/Terms-and-Conditions>, and for electronic format documents, subject to Terms and Conditions for Electronic Documents at <http://www.sgs.com.tw/Terms-and-Conditions>. Attention is drawn to the limitation of liability, indemnification and jurisdiction issues defined therein. Any holder of this document is advised that information contained hereon reflects the Company's findings at the time of its intervention only and within the limits of Client's instructions, if any. The Company's sole responsibility is to its Client and this document does not exonerate parties to a transaction from exercising all their rights and obligations under the transaction documents. This document cannot be reproduced except in full, without prior written approval of the Company. Any unauthorized alteration, forgery or falsification of the content or appearance of this document is unlawful and offenders may be prosecuted to the fullest extent of the law.



#### 14.4 Measurement Result

##### GFSK (1Mbps)

Channel	PACKET TYPE	Measurement Result (ms)	Limit (ms)
Mid	DH1	123.20	400
	DH3	262.40	400
	DH5	308.80	400

##### $\pi/4$ DQPSK (2Mbps)

Channel	PACKET TYPE	Measurement Result (ms)	Limit (ms)
Mid	2DH1	124.80	400
	2DH3	262.40	400
	2DH5	308.80	400

##### 8-DPSK (3Mbps)

Channel	PACKET TYPE	Measurement Result (ms)	Limit (ms)
Mid	3DH1	124.80	400
	3DH3	262.40	400
	3DH5	307.20	400

Unless otherwise stated the results shown in this test report refer only to the sample(s) tested and such sample(s) are retained for 90 days only.

除非另有說明，此報告結果僅對測試之樣品負責，同時此樣品僅保留90天。本報告未經本公司書面許可，不可部份複製。

This document is issued by the Company subject to its General Conditions of Service printed overleaf, available on request or accessible at <http://www.sgs.com.tw/Terms-and-Conditions> and for electronic format documents, subject to Terms and Conditions for Electronic Documents at <http://www.sgs.com.tw/Terms-and-Conditions>. Attention is drawn to the limitation of liability, indemnification and jurisdiction issues defined therein. Any holder of this document is advised that information contained hereon reflects the Company's findings at the time of its intervention only and within the limits of Client's instructions, if any. The Company's sole responsibility is to its Client and this document does not exonerate parties to a transaction from exercising all their rights and obligations under the transaction documents. This document cannot be reproduced except in full, without prior written approval of the Company. Any unauthorized alteration, forgery or falsification of the content or appearance of this document is unlawful and offenders may be prosecuted to the fullest extent of the law.

**GFSK (1Mbps):**

CH Mid	DH1 time slot	=	0.385	*	(1600/2/79)	*	31.6	=	123.20	(ms)
	DH3 time slot	=	1.640	*	(1600/4/79)	*	31.6	=	262.40	(ms)
	DH5 time slot	=	2.895	*	(1600/6/79)	*	31.6	=	308.80	(ms)

**$\pi/4$  -DQPSK (2Mbps):**

CH Mid	2DH1 time slot	=	0.390	*	(1600/2/79)	*	31.6	=	124.80	(ms)
	2DH3 time slot	=	1.640	*	(1600/4/79)	*	31.6	=	262.40	(ms)
	2DH5 time slot	=	2.895	*	(1600/6/79)	*	31.6	=	308.80	(ms)

**8-DPSK (3Mbps):**

CH Mid	3DH1 time slot	=	0.390	*	(1600/2/79)	*	31.6	=	124.80	(ms)
	3DH3 time slot	=	1.640	*	(1600/4/79)	*	31.6	=	262.40	(ms)
	3DH5 time slot	=	2.880	*	(1600/6/79)	*	31.6	=	307.20	(ms)

A period time = 0.4 (s) \* 79 = 31.6 (s)

Unless otherwise stated the results shown in this test report refer only to the sample(s) tested and such sample(s) are retained for 90 days only.

除非另有說明，此報告結果僅對測試之樣品負責，同時此樣品僅保留90天。本報告未經本公司書面許可，不可部份複製。

This document is issued by the Company subject to its General Conditions of Service printed overleaf, available on request or accessible at <http://www.sgs.com.tw/Terms-and-Conditions> and for electronic format documents, subject to Terms and Conditions for Electronic Documents at <http://www.sgs.com.tw/Terms-and-Conditions>. Attention is drawn to the limitation of liability, indemnification and jurisdiction issues defined therein. Any holder of this document is advised that information contained hereon reflects the Company's findings at the time of its intervention only and within the limits of Client's instructions, if any. The Company's sole responsibility is to its Client and this document does not exonerate parties to a transaction from exercising all their rights and obligations under the transaction documents. This document cannot be reproduced except in full, without prior written approval of the Company. Any unauthorized alteration, forgery or falsification of the content or appearance of this document is unlawful and offenders may be prosecuted to the fullest extent of the law.

Dwell Time\_GFSK\_1M\_DH1\_2441MHz

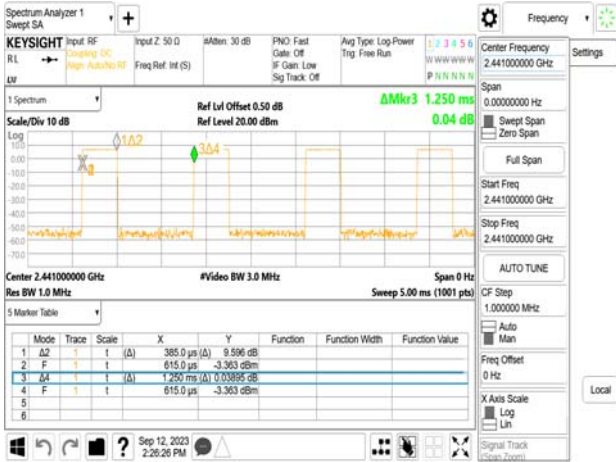

Dwell Time\_π/4DQPSK\_2M\_DH1\_2441MHz



Dwell Time\_GFSK\_1M\_DH3\_2441MHz

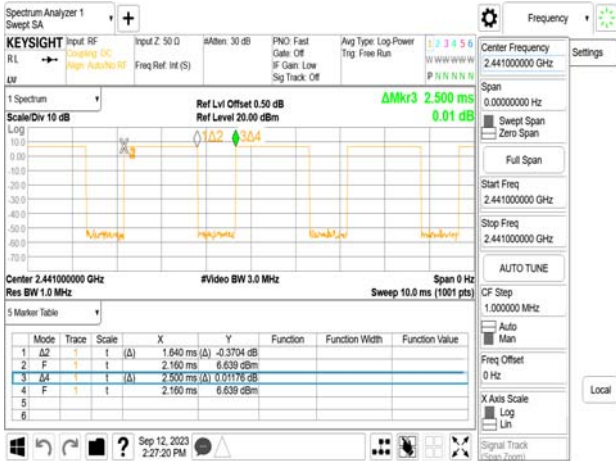

Dwell Time\_π/4DQPSK\_2M\_DH3\_2441MHz



Dwell Time\_GFSK\_1M\_DH5\_2441MHz

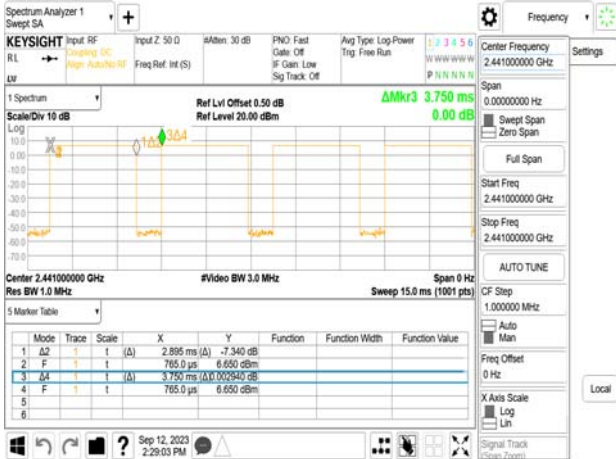

Dwell Time\_π/4DQPSK\_2M\_DH5\_2441MHz



Unless otherwise stated the results shown in this test report refer only to the sample(s) tested and such sample(s) are retained for 90 days only.

除非另有說明，此報告結果僅對測試之樣品負責，同時此樣品僅保留90天。本報告未經本公司書面許可，不可部份複製。

This document is issued by the Company subject to its General Conditions of Service printed overleaf, available on request or accessible at <http://www.sgs.com.tw/Terms-and-Conditions> and for electronic format documents, subject to Terms and Conditions for Electronic Documents at <http://www.sgs.com.tw/Terms-and-Conditions>. Attention is drawn to the limitation of liability, indemnification and jurisdiction issues defined therein. Any holder of this document is advised that information contained hereon reflects the Company's findings at the time of its intervention only and within the limits of Client's instructions, if any. The Company's sole responsibility is to its Client and this document does not exonerate parties to a transaction from exercising all their rights and obligations under the transaction documents. This document cannot be reproduced except in full, without prior written approval of the Company. Any unauthorized alteration, forgery or falsification of the content or appearance of this document is unlawful and offenders may be prosecuted to the fullest extent of the law.

Dwell Time\_8DPSK\_3M\_DH1\_2441MHz

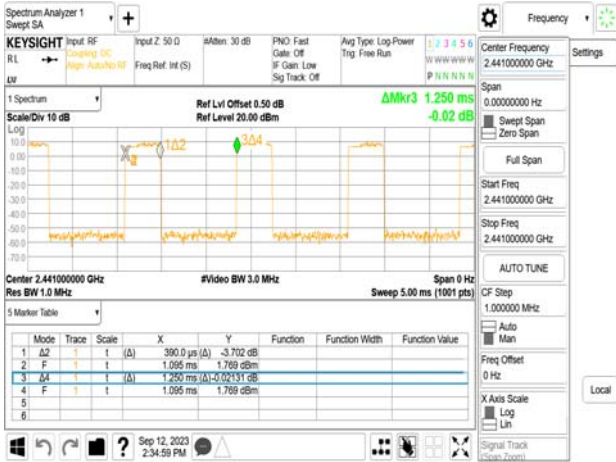

Dwell Time\_8DPSK\_3M\_DH3\_2441MHz



Dwell Time\_8DPSK\_3M\_DH5\_2441MHz



Unless otherwise stated the results shown in this test report refer only to the sample(s) tested and such sample(s) are retained for 90 days only.

除非另有說明，此報告結果僅對測試之樣品負責，同時此樣品僅保留90天。本報告未經本公司書面許可，不可部份複製。

This document is issued by the Company subject to its General Conditions of Service printed overleaf, available on request or accessible at <http://www.sgs.com.tw/Terms-and-Conditions>, and for electronic format documents, subject to Terms and Conditions for Electronic Documents at <http://www.sgs.com.tw/Terms-and-Conditions>. Attention is drawn to the limitation of liability, indemnification and jurisdiction issues defined therein. Any holder of this document is advised that information contained hereon reflects the Company's findings at the time of its intervention only and within the limits of Client's instructions, if any. The Company's sole responsibility is to its Client and this document does not exonerate parties to a transaction from exercising all their rights and obligations under the transaction documents. This document cannot be reproduced except in full, without prior written approval of the Company. Any unauthorized alteration, forgery or falsification of the content or appearance of this document is unlawful and offenders may be prosecuted to the fullest extent of the law.

## 15 ANTENNA REQUIREMENT

### 15.1 Standard Applicable

An intentional radiator shall be designed to ensure that no antenna other than that furnished by the responsible party shall be used with the device. The use of a permanently attached antenna or of an antenna that uses a unique coupling to the intentional radiator shall be considered sufficient to comply with the provisions of this section. The manufacturer may design the unit so that a broken antenna can be replaced by the user, but the use of a standard antenna jack or electrical connector is prohibited. This requirement does not apply to carrier current devices or to devices operated under the provisions of §§ 15.211, 15.213, 15.217, 15.219, 15.221, or § 15.236. Further, this requirement does not apply to intentional radiators that must be professionally installed, such as perimeter protection systems and some field disturbance sensors, or to other intentional radiators which, in accordance with § 15.31(d), must be measured at the installation site. However, the installer shall be responsible for ensuring that the proper antenna is employed so that the limits in this part are not exceeded.

### 15.2 Antenna Connected Construction:

The antenna complies with this requirement and no consideration of replacement. Please see EUT photo for details.

*~ End of Report ~*

Unless otherwise stated the results shown in this test report refer only to the sample(s) tested and such sample(s) are retained for 90 days only.  
除非另有說明，此報告結果僅對測試之樣品負責，同時此樣品僅保留90天。本報告未經本公司書面許可，不可部份複製。

This document is issued by the Company subject to its General Conditions of Service printed overleaf, available on request or accessible at <http://www.sgs.com.tw/Terms-and-Conditions>, and for electronic format documents, subject to Terms and Conditions for Electronic Documents at <http://www.sgs.com.tw/Terms-and-Conditions>. Attention is drawn to the limitation of liability, indemnification and jurisdiction issues defined therein. Any holder of this document is advised that information contained hereon reflects the Company's findings at the time of its intervention only and within the limits of Client's instructions, if any. The Company's sole responsibility is to its Client and this document does not exonerate parties to a transaction from exercising all their rights and obligations under the transaction documents. This document cannot be reproduced except in full, without prior written approval of the Company. Any unauthorized alteration, forgery or falsification of the content or appearance of this document is unlawful and offenders may be prosecuted to the fullest extent of the law.