

KOWO®

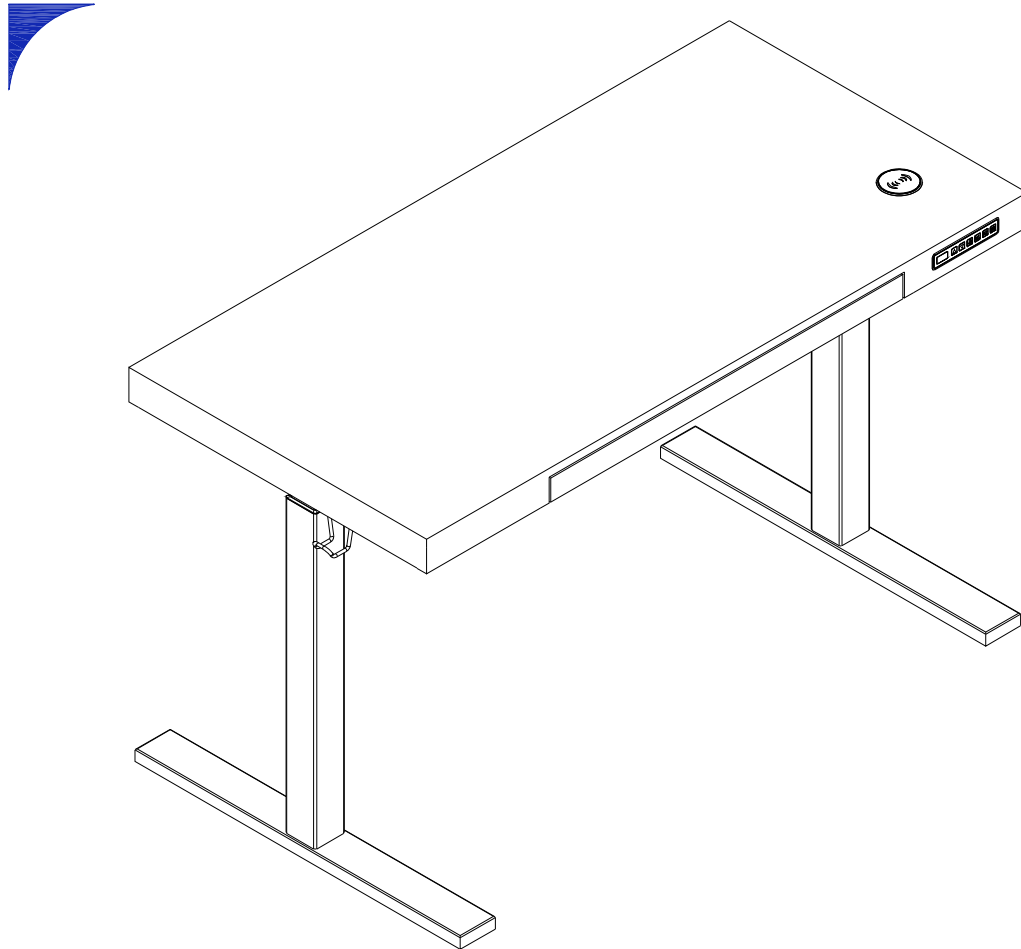

Standing Desk

K305-11-12

K305-21-12

K305-31-12

Any questions or issues please contact us

www.kowohome.com

Tel : 888-672-0882

Email: service@kowohome.com

10:00 AM - 7:00 PM EST Monday - Saturday

Specifications

Max. Weight Capacity	110 lbs (50kg)
Speed	25mm/s
Input Voltage	120 V
Min. Height	28.9" (735mm)
Max. Height	47.2" (1200mm)
Duty Cycle	10% (Working 2 minutes then stop 18 minutes)
Certification	FCC

Accessory Package

PLEASE NOTE: Check that you have received all components and hardware before assembling. If you are missing any parts, please contact us for replacement parts.

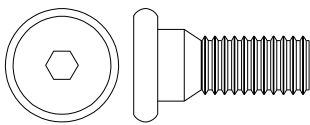

A. 3/4" Medium Machine Screw - 8

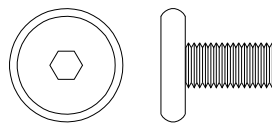

B. 1/2" Small Machine Screw - 8

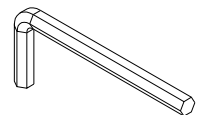

C. Wrench - 1

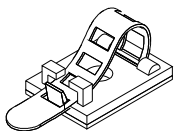

D. Self-adhesive Cable Strap - 3

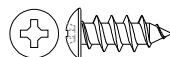

E. 1/2" Wood Screw - 7

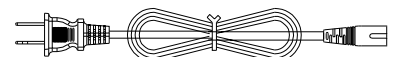

F. Power Cord - 1

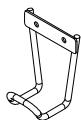

G. Hooks - 2

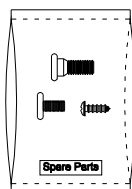

H. Spare Parts - 1

Diagram of Components

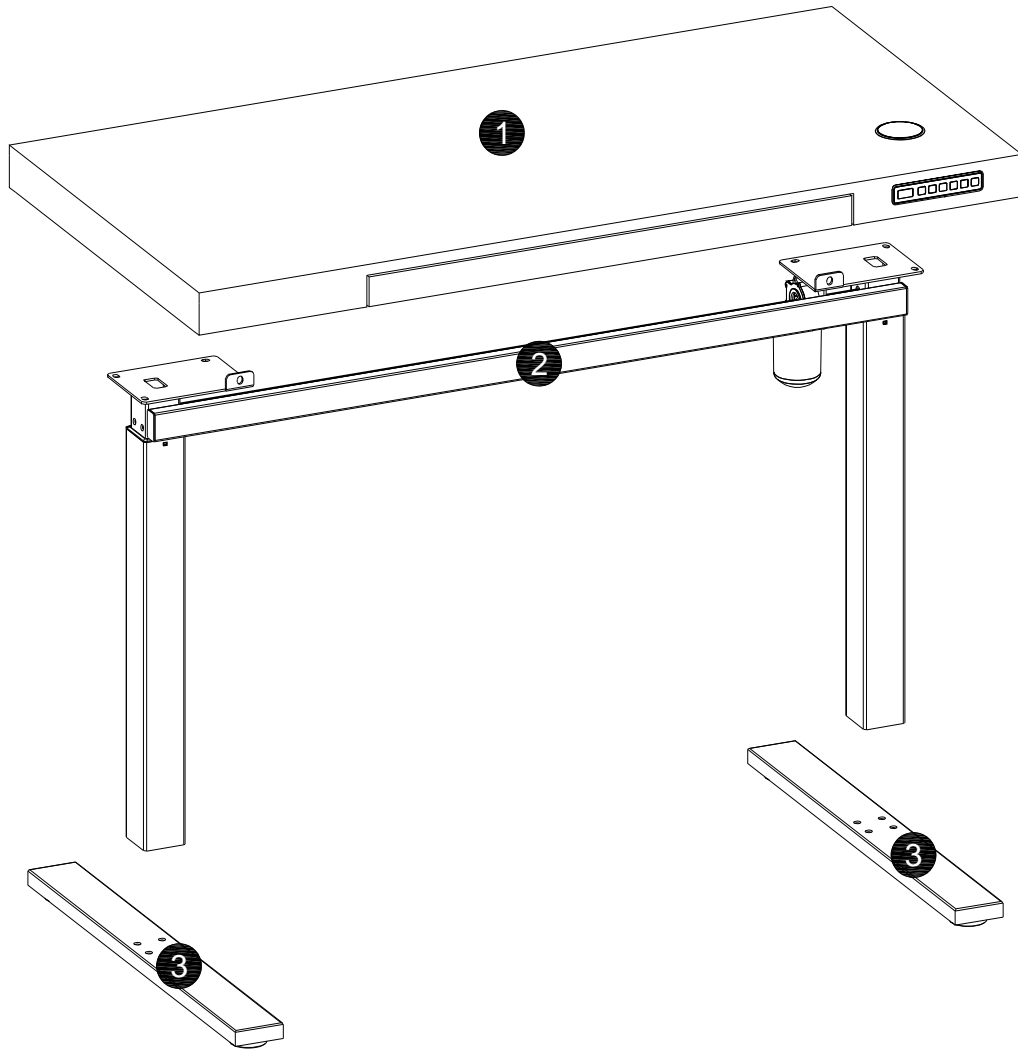

Parts Included

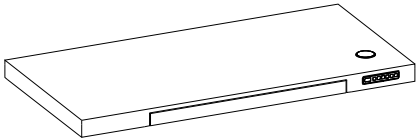
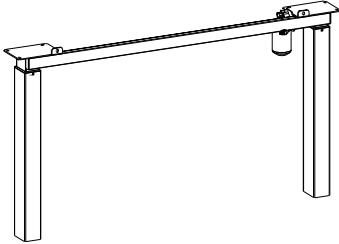
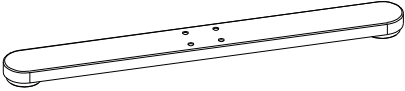
NO.	Parts	Qty	NO.	Parts	Qty
1	 Tabletop	1	2	 Supporting Leg Frame	1
3	 Foot Bar	2			

STEP 1

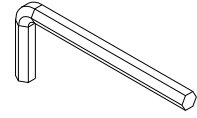
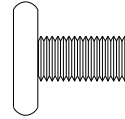
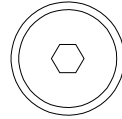
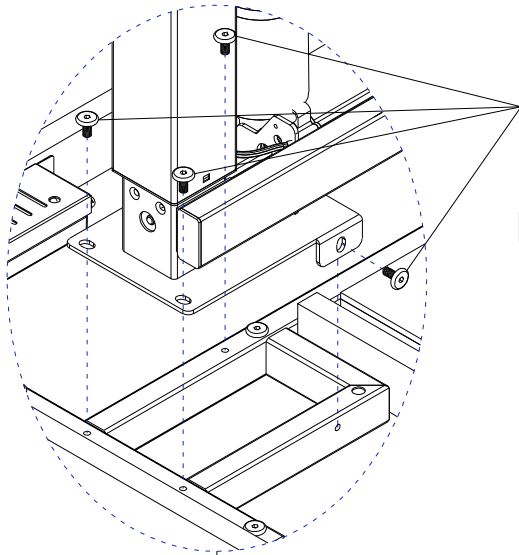

B. 1/2" Small Machine Screw - 8

C. Wrench - 1

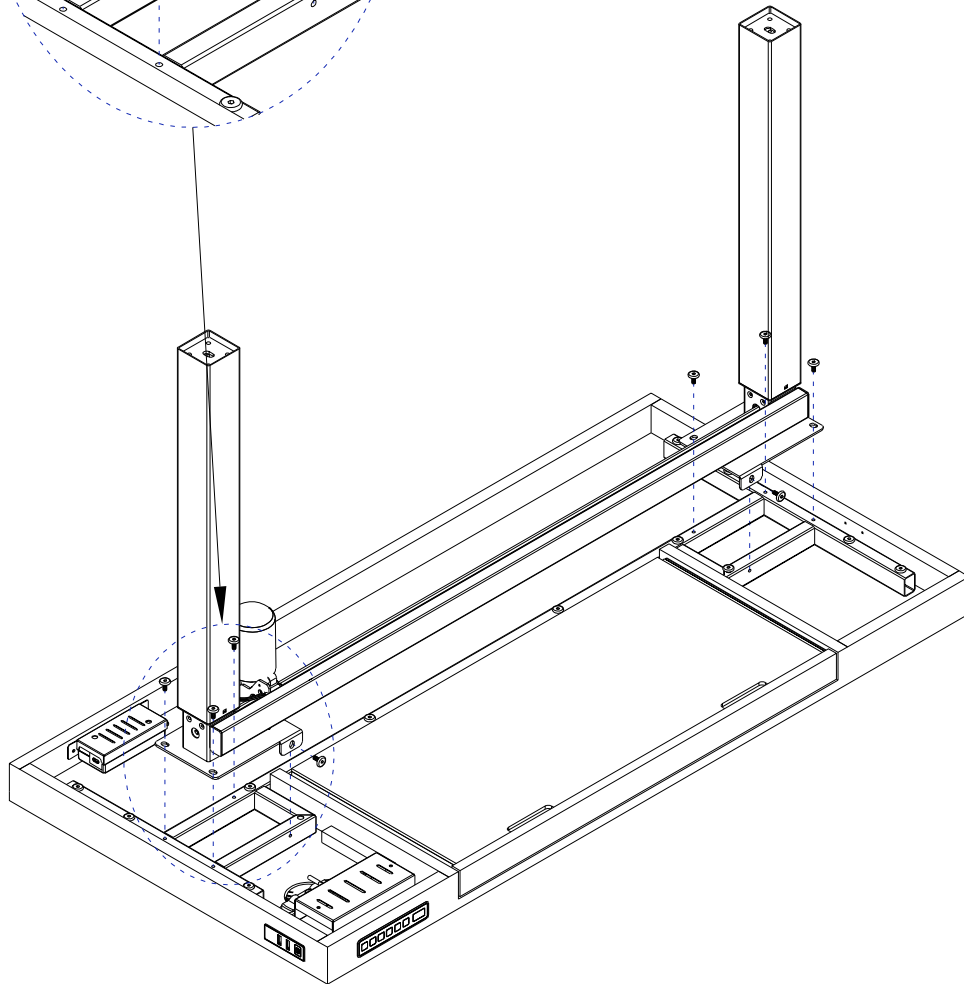

STEP 2

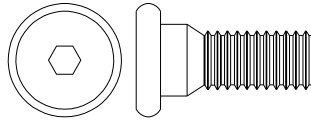
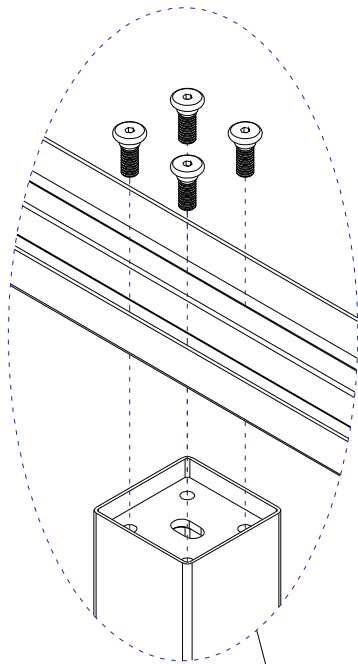

A. 3/4" Medium Machine Screw - 8

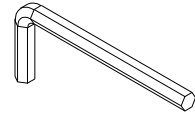

C. Wrench - 1

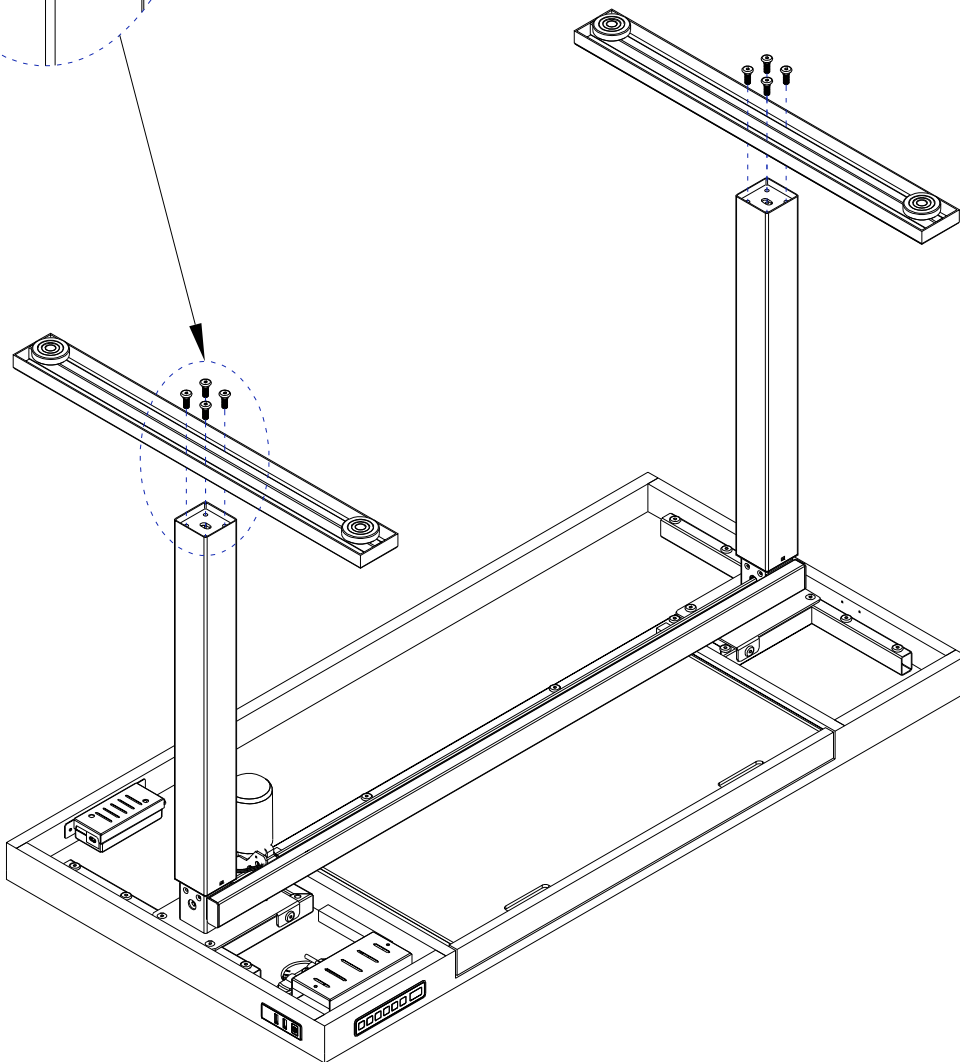

STEP 3

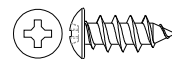
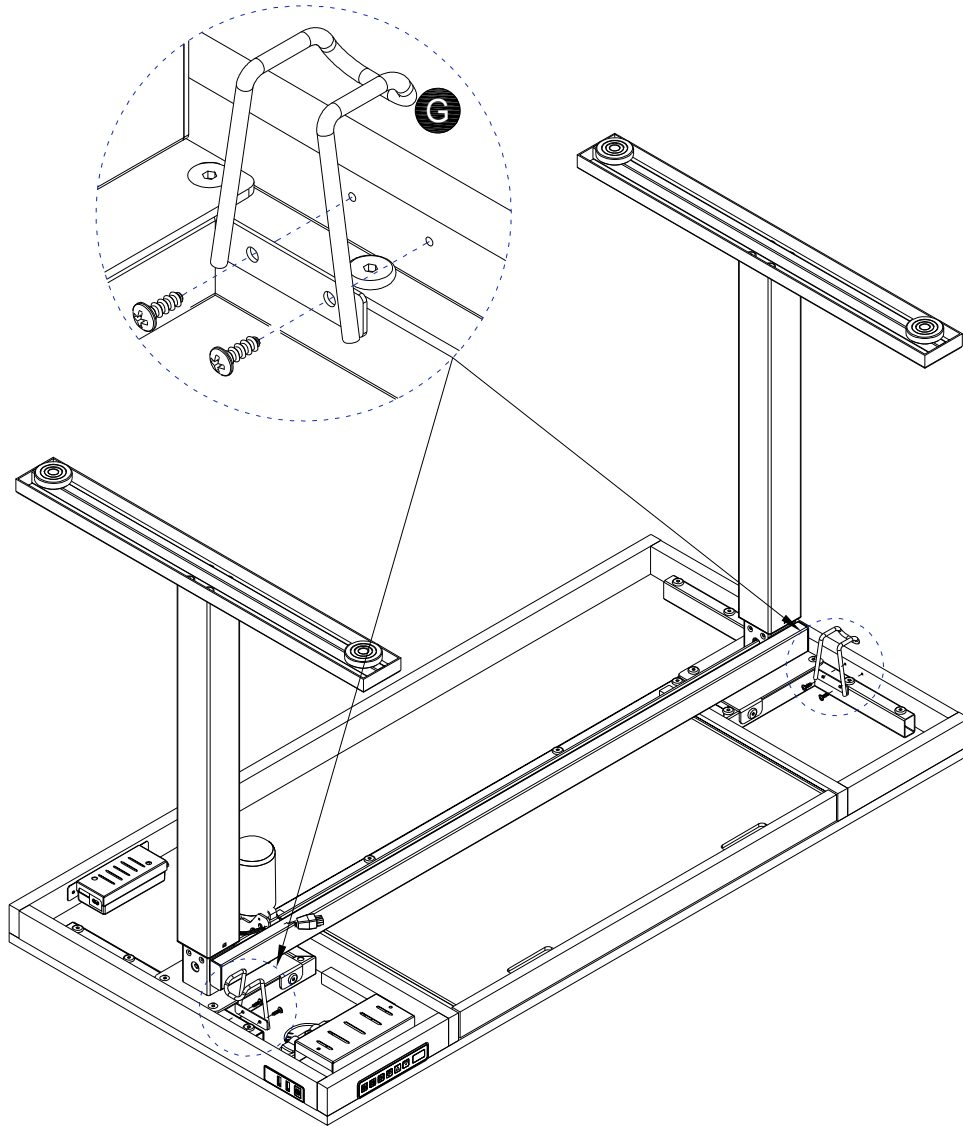

E. 1/2" Wood Screw - 4

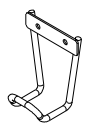

G. Hooks - 2

STEP 4

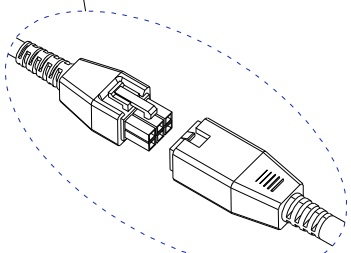
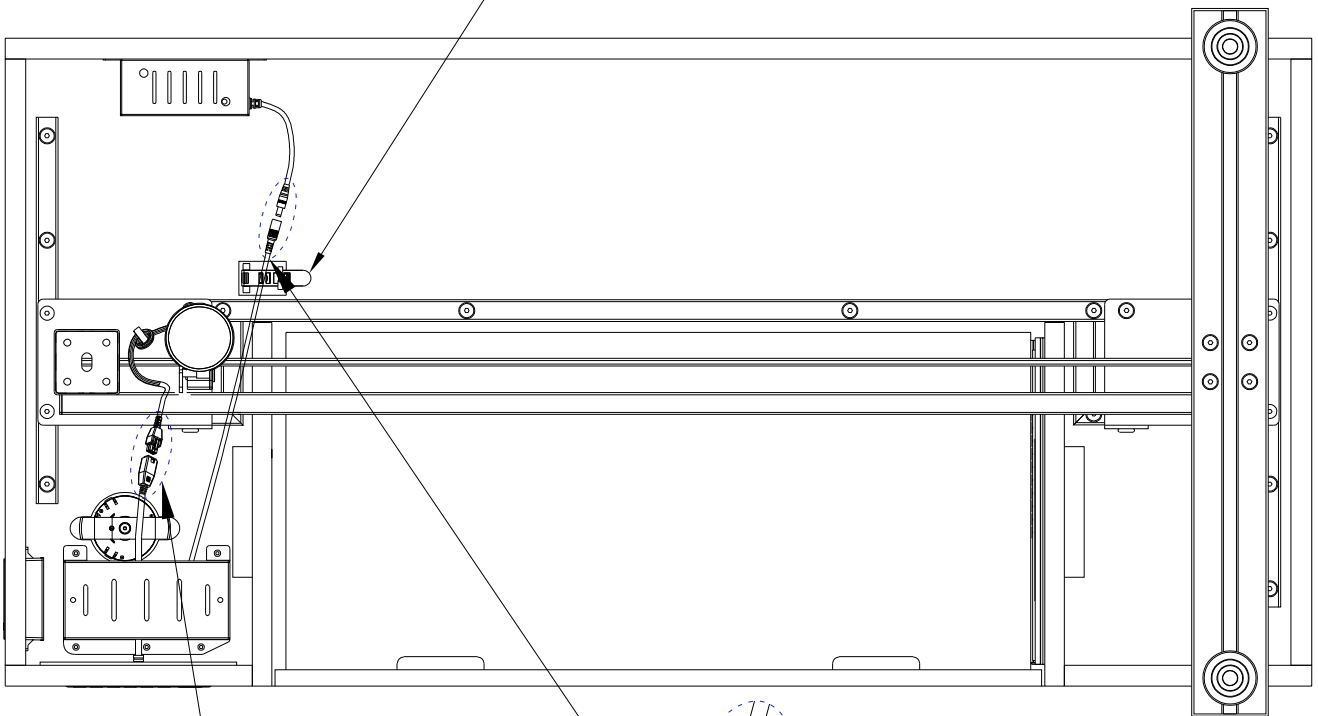
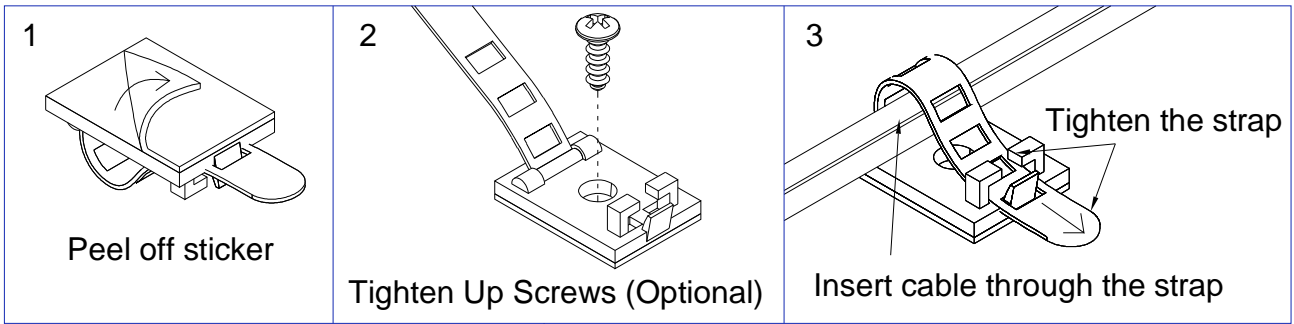

Interface for motor cable

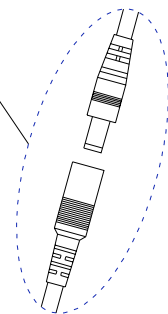

Power Cord

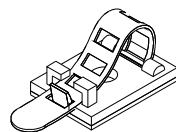

D. Self-adhesive Cable Strap - 3



E. 1/2" Wood Screw - 3

STEP 5

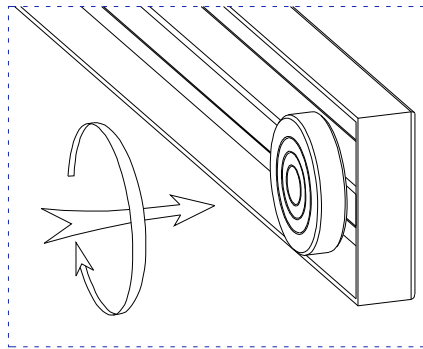
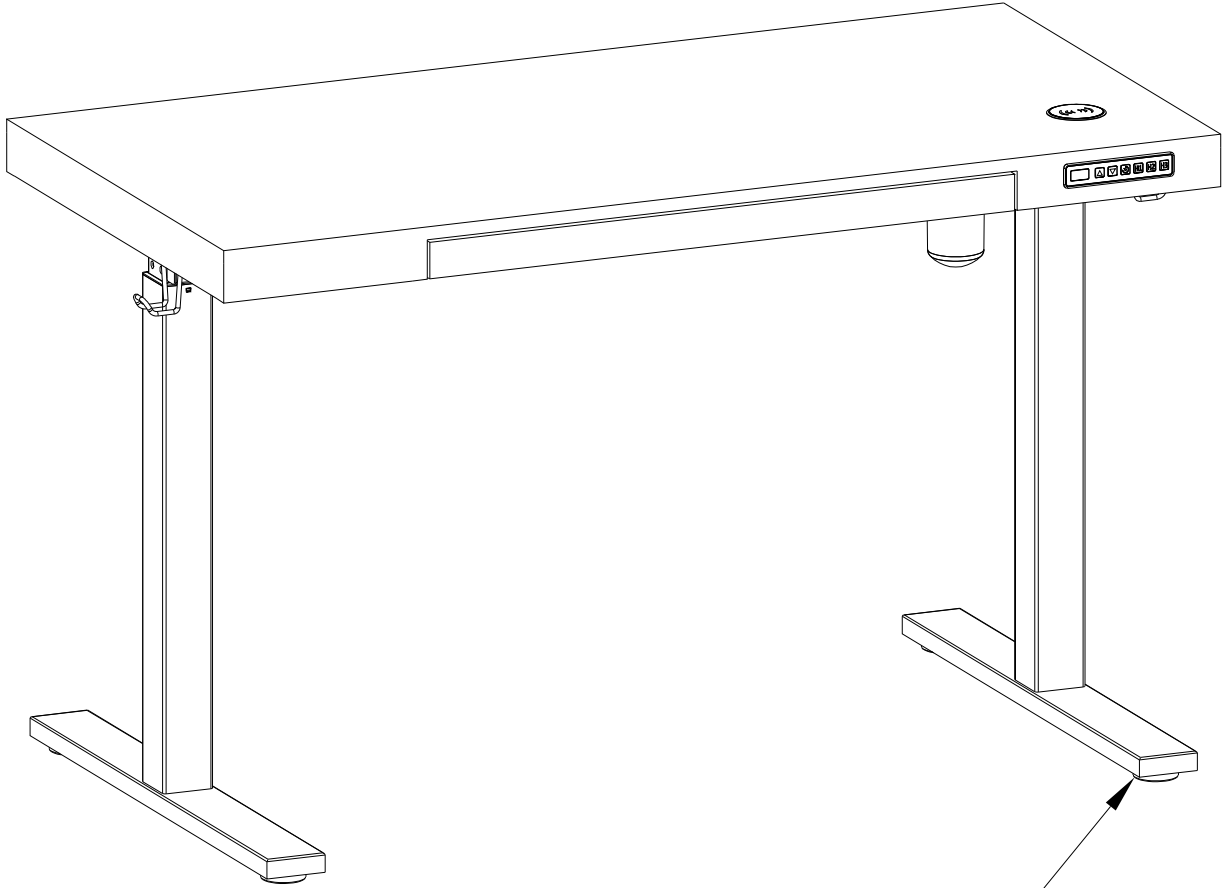

Leveling foot adjustment

STEP 6

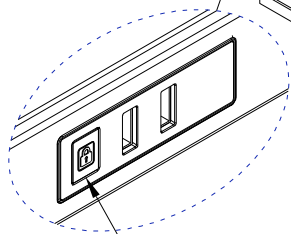
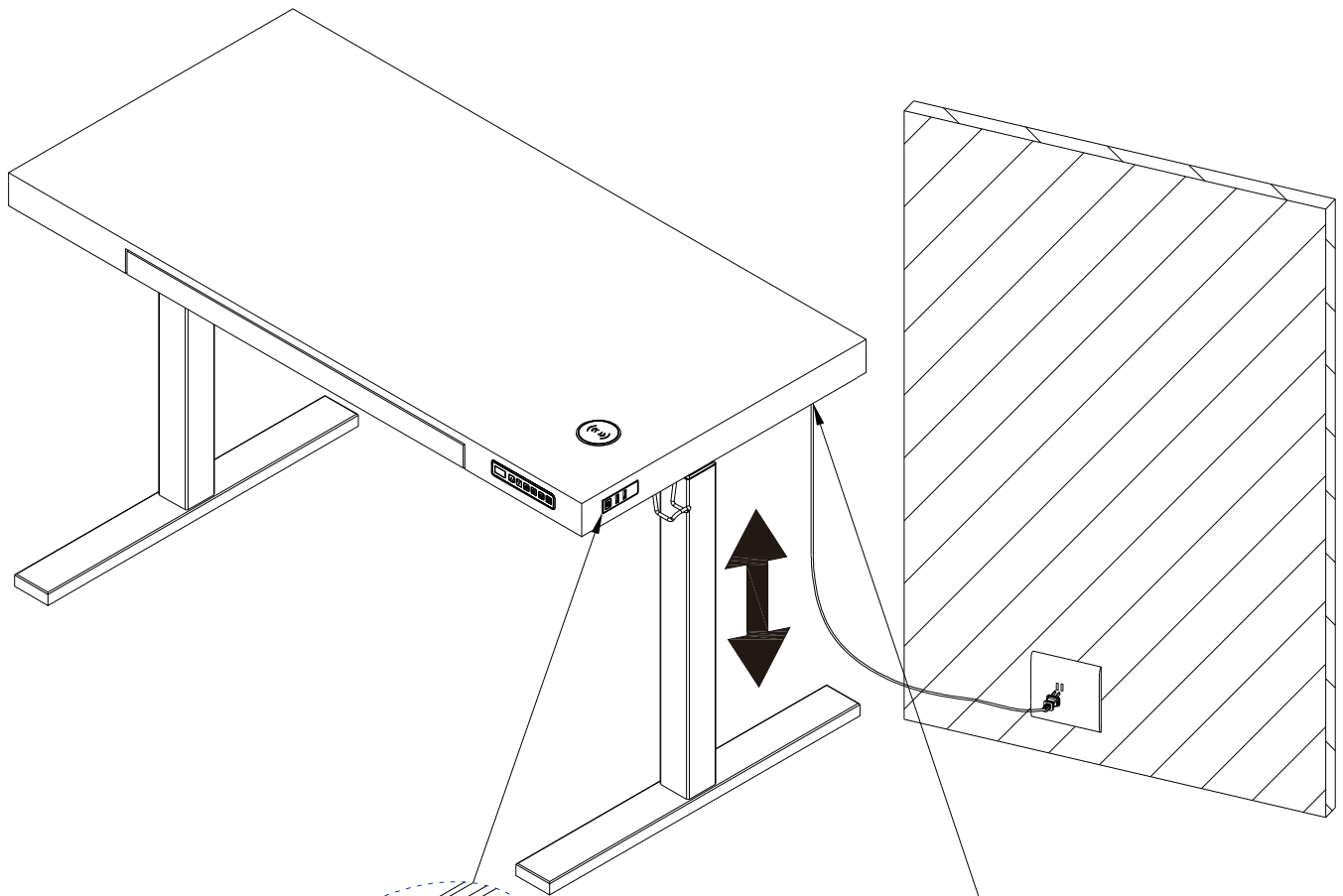

The 'Child Lock' button is for height position lock and factory reset purpose. Factory reset is required for first time initialization

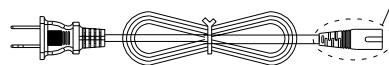
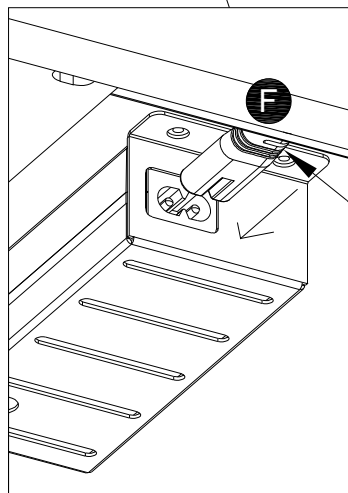

F.Power Cord- 1

STEP 7

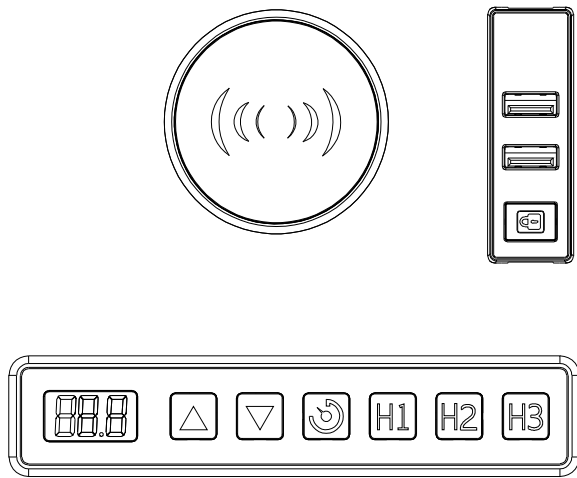

Handset Instruction	
Button	Functionality
	REMINDER button, to activate the " Long-Time Sitting Reminder " function
	UP Button, to lift the desk surface
	DOWN Button, to lower the desk surface
	LED Display
H1	Position 1, User saves the 1st Height Position
H2	Position 2, User saves the 2nd Height Position
H3	Position 3, User saves the 3rd Height Position
	Child Lock , to Lock/Unlock height position, and factory reset purpose.
	USB
	Wireless Charger

Operation Guide

Reset Process

- Factory reset is required for first time initialization or when power cut off due to electrical problems.
- Make sure all cables are connected properly before initialization.
- Press and hold the button. (Please do not release the button until connects to power)
- Connect outlet to the power supply.
- LED display shows "AES" then release the button, desktop goes down automatically until it reaches its lowest height then rebound to factory reset height.
- LED display shows "60.2", the initialization is completed.
 - After the reset process, press the **UP** or **DOWN** button to lift or lower the height of desktop. The LED display shows the real time numerical value. The range of numerical value: 28.5"-47.2".

Memory setting for height position

- Press the **UP** or **DOWN** button to lift or lower height of desktop.
- You can adjust the height to 35" then press button "H1" for 5 seconds, LED display starts flashing and you saved the 1st height position to 35".
- Repeat the same process to save 2nd and 3rd height position accordingly.
- Press button "H1", "H2" and "H3" to reach the saved height position.

Long-Time Sitting Reminder

- Press REMINDER button to activate the function. The LED display start flashing and shows "00"
- Press **UP** or **DOWN** button to adjust countdown time setting. Re-press the button to confirm and LED display stops flashing, countdown timing is set.
- When the countdown finished, the buzzer will activate automatically with sound.
- To de-activate the countdown, press button and set timing to "00" by using the **UP** or **DOWN** button, then press button to confirm.
- The button is to lock height position from preventing further adjustment. To unlock it, simply press it again.

Troubleshooting

This list is used for checking and solving common faults and errors. The LED displays an error code with warning sound when problem occurs. In most cases, problem should be resolved by reconnecting cables and run a factory reset mode. If problem you encounter is not on the list below, please contact the manufacturer for assistance.

Error Code	Faults	Solution
E1	Excessive overtime operation	Automatic recovery after stop using for 18 minutes
E2	Overloading	Reduce weight of loading
E3	Connection cable failure	Check all cables (Power cord, handset cable, motor cable) and power plug are connected properly
E4	Power voltage unmatched	Check voltage of power supply or contact manufacture
RES	Factory reset mode request	Run a factory reset process (Page 10)
E11	Handset fault	Reconnect handset cable, or contact manufacture if problem does not solve
E12	Control box fault	Run a factory reset process, contact manufacture if problem does not solve

Attention

- Power supply: AC120V \pm 10%, frequency 60HZ;
- Working environment: 32° - 104° F ;
- Before cleaning, you have to unplug the power supply cable. Clean with a slightly damp cloth to wipe away the surface dust. Keep all electrical components away from liquids. Do not damage the connection line and keep the plug in a safe position.
- Inside the control box, there are electronic components, metal parts, plastic parts, wires and so on. They should be disposed in accordance with the local laws and regulations. They cannot be disposed as household waste.
- Before using the product, please make sure the product has been installed correctly.
- Before starting use of the product, please read the instructions to fully understand all the product's functions and settings.
- Keep children away from electric height-adjustable desks, control units and handsets. Manufacturer is not responsible of any damages that result from children's unpredictable behaviour.
- Slight noise caused by the multi wedge belt or brake system will not impact the use of this product.
- Do not use corrosive or abrasive materials to clean this product and please dispose of cleaning solutions in an environmentally friendly manner.
- Understand the risks associated with using this product. Children or those with cognitive impairment should not use this product without supervision.
- If the power supply cord is damaged or broken, it must be replaced by the manufacturer or a relevant specialist to avoid any injuries.
- Please operate in a clean and safe environment. For example, do not left around your tools. And always be careful to deal with packaging materials, in order to avoid any kinds of possible danger. Potential choking risk exists when children play with plastic bags!
- If necessary, retain the original package for future transportation.

Recycling and Disposal



This product cannot be disposed of as household waste. To prevent damage to the environment, this product should be recycled. Please use the relevant recycling systems available to you or contact the distributor or manufacturer for recycling assistance.

FCC STATEMENT :

This device complies with Part 15 of the FCC Rules. Operation is subject to the following two conditions:

This device may not cause harmful interference, and

This device must accept any interference received, including interference that may cause undesired operation. Warning: Changes or modifications not expressly approved by the party responsible for compliance could void the user's authority to operate the equipment.

NOTE: This equipment has been tested and found to comply with the limits for a Class B digital device, pursuant to Part 15 of the FCC Rules. These limits are designed to provide reasonable protection against harmful interference in a residential installation. This equipment generates uses and can radiate radio frequency energy and, if not installed and used in accordance with the instructions, may cause harmful interference to radio communications. However, there is no guarantee that interference will not occur in a particular installation. If this equipment does cause harmful interference to radio or television reception, which can be determined by turning the equipment off and on, the user is encouraged to try to correct the interference by one or more of the following measures:

Reorient or relocate the receiving antenna.

Increase the separation between the equipment and receiver.

Connect the equipment into an outlet on a circuit different from that to which the receiver is connected. Consult the dealer or an experienced radio/TV technician for help.

FCC Radiation Exposure Statement:

This equipment complies with FCC radiation exposure limits set forth for an uncontrolled environment. This equipment should be installed and operated with minimum distance 20cm between the radiator & your body.