名称/TYPE MP-A2/15W/12T

产品型号

Model NO ni=10uH ±10%

Enginrer NO

日期/Date 2022-4-23

编制/Prepared 审核/Checked 认可/Approved

万纪美 刘成昭 江忠情

一、 线圈工艺/Winding Procese:

NO	绕组 Winding	线规 Wire gauge	匝数 Number of turns	绕线方向 Winding direction	备注 Remark
1	N1	2UEW-B-0.08*105P	12TS	CCW	
2					

二. 电气性能/FEATURES:

1.测试条件 (Test conditions) : 25°C,65%RH@100KHz/1V

1.1 电感量 (Inductance)

1.11 L0A(线圈+磁片 Coil + magnetic piece)=10uH-5%

1.2 Q 值=90MIN

1.3 直流电阻 (DCR) : 85mΩ MAX

1.4 工作温度(Operating Temperature): -25°C~85°C

2.测试仪器(Test instrument): L:创达 1068+1310;DCR:502BC;SIZE:Callipers

3.材料清单 Material list

NO	项目	材料 Material
1	WIRE	φ 0.08*105p 2UEW-1.1mm
2	FERRITE	50*5.3*1.0 Double slot with holes ferrite hard magnet
3	GLUE	白胶 white glue
4	SOLDER	XCD-907B
5	Adhesive	双面背胶 Double sided adhesive tape
6	High temperature adhesive	8MM heat resistant tape
7		
8		

三. 电路图/CIRCUIT DIAGRAM

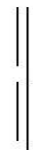
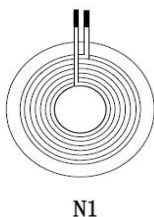

单位: MM

四. 外形图/OUTSIDE DIAGRA

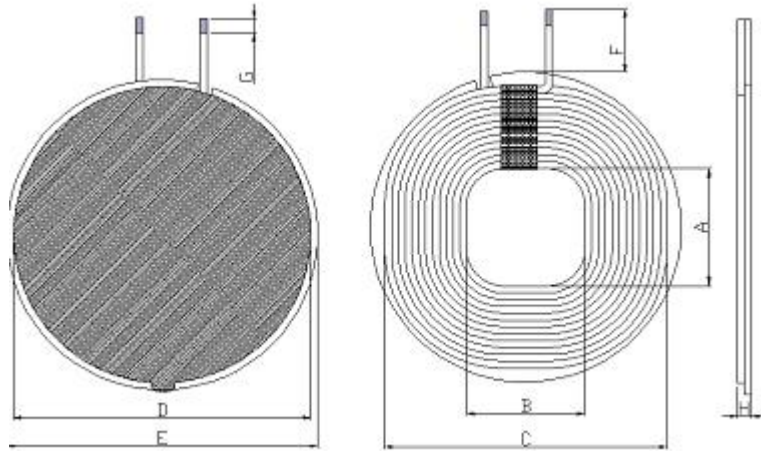

注：线圈出线位置缠绕 8MM (ref) 高温胶纸，线圈贴在黑色 PE 膜上

Note: The coil outlet position is wrapped with 8MM (ref) high-temperature tape, and the coil is attached to the black PE film

标准 standard	A	B	C	D	E	F	H	
STD	18.5±0.5	18.5±0.5	49±0.5	48.5±0.2	50±0.5	4±1	2.3Max	

单位： MM

五. 包装/PACKAGE

5.1 包装图片 Packing pictures:

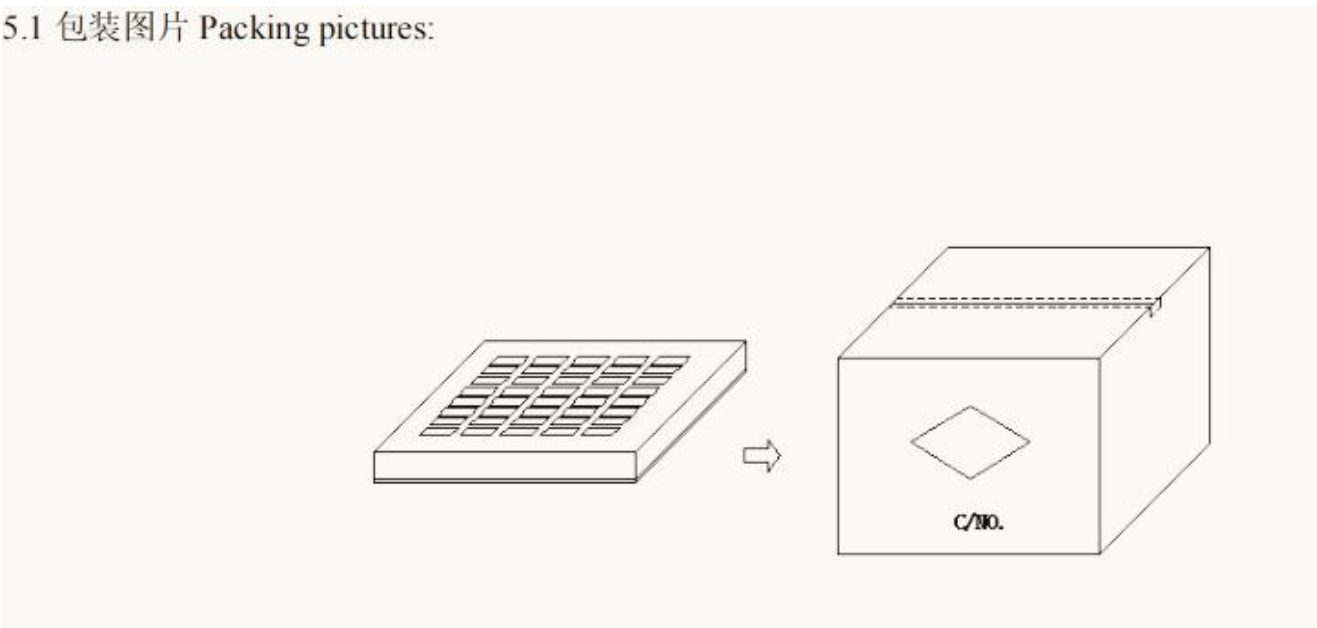

5.2 包装数量及规格 Packing Quantity:

项目 Item	数量 Quantity	材料规格 Material
盒 Box	350 Pcs	345*330*50 mm
箱 Big Carton	1750 Pcs	360*340*280 mm

5.3 包装以现有包装盘为参照标准，以实际出货包装为准，如有特需要求可以定制。

The packaging shall be based on the existing packing plate and the actual delivery package shall prevail .If there is any requirement,we can customize it.

Sample Test Data

客户		客户编号		日期	2019-7-3		文件编号			
产品编号		产品规格	5.0*5.3*1.0		版本	0A		页码		
测试项目	特性测试				尺寸测量					
	<i>Ls</i>	<i>Q</i>	<i>DCR</i>	<i>A</i>	<i>B</i>	<i>C</i>	<i>D</i>	<i>E</i>	<i>F</i>	<i>H</i>
规格标准	10	≥90	≤85	50±0.5	48±1	19±0.5	30±2	10±1	3±1	4.0Max
单位	<i>uH</i>		<i>mΩ</i>	<i>MM</i>						
测试条件	<i>LCR (测试仪 1 KHZ / 1.0 V)</i>				<i>Digital Caliper</i>					
TEST DATA										
<i>No1.</i>	<i>9.60</i>	<i>119.9</i>	<i>66.18</i>	<i>49.84</i>	<i>47.71</i>	<i>19.43</i>	<i>30.98</i>	<i>10.77</i>	<i>3.37</i>	<i>3.55</i>
<i>No2.</i>	<i>9.68</i>	<i>111.7</i>	<i>65.86</i>	<i>49.86</i>	<i>47.77</i>	<i>19.43</i>	<i>30.19</i>	<i>10.94</i>	<i>3.58</i>	<i>3.57</i>
<i>No3.</i>	<i>9.67</i>	<i>13.6</i>	<i>65.99</i>	<i>49.96</i>	<i>47.64</i>	<i>19.46</i>	<i>30.91</i>	<i>10.92</i>	<i>3.39</i>	<i>3.52</i>
<i>No4.</i>	<i>9.61</i>	<i>121.3</i>	<i>66.08</i>	<i>49.88</i>	<i>47.71</i>	<i>19.42</i>	<i>30.11</i>	<i>10.97</i>	<i>3.47</i>	<i>3.54</i>
<i>No5.</i>	<i>9.20</i>	<i>116.5</i>	<i>65.79</i>	<i>49.90</i>	<i>47.47</i>	<i>19.34</i>	<i>30.84</i>	<i>10.94</i>	<i>3.58</i>	<i>3.43</i>
<i>No6.</i>										
<i>No7.</i>										
判定结果	<i>OK</i>	<i>OK</i>	<i>OK</i>	<i>OK</i>	<i>OK</i>	<i>OK</i>	<i>OK</i>	<i>OK</i>	<i>OK</i>	<i>OK</i>
备注:						<i>Approval</i>				
						<i>Drawn</i>	<i>Checked</i>	<i>Approved</i>	Customer Approval	
						<i>万纪美</i>	<i>刘成昭</i>	<i>江忠情</i>		