

# RETG<sup>V</sup>IS

## INSTRUCTION MANUAL

- Weather Channel Receive, Vibration Draining Function
- IPX7 Waterproof (1 meter depth for 30 minutes)
- Built-in GPS, Built-in DSC, MOB Function

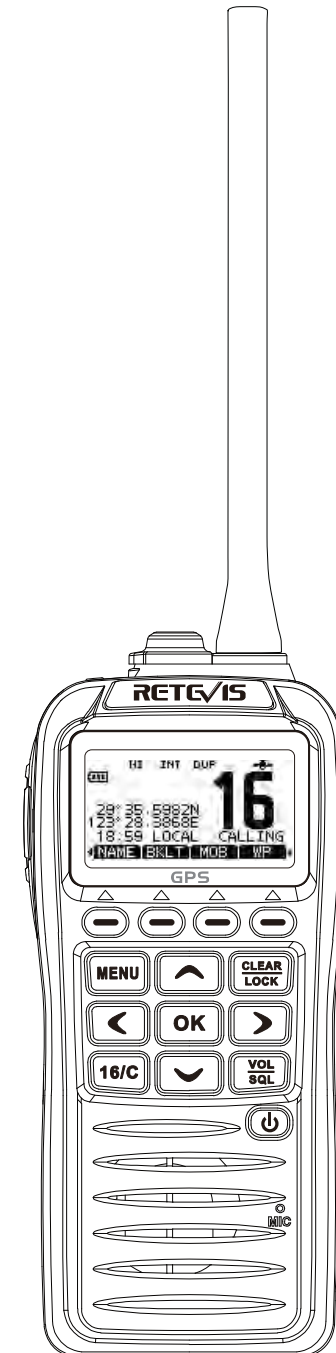

## Foreword

Thank you for purchasing this VHF marine radio. You will find the professional and humanized design of the radio during using. Please read all instructions carefully and completely before using.

It is a multifunctional and well-designed VHF marine radio which meets the IMO (International Maritime Organization) regulation.

This radio has built-in GPS, can indicate ship latitude and longitude, time and other information. It has navigation and MOB functions.

The built-in digital selective call DSC function can achieve all kinds of DCS call including distress call.

As adopting advance waterproof technology, the radio is with good waterproof performance, can float and flash alarm when drops into the water.

EU Importer: Germany Retevis Technology GmbH  
Address: Uetzenacker 29,38176 wendeburg

## CAUTION

- The power supply of this radio is DC 7.4V. Please use the li-ion battery as configured.
- The radio should be charged by the configured adaptor.
- Do not expose the radio to direct sunlight for a long time. Do not place it in environment or near any heating devices below  $-20^{\circ}\text{C}$  or above  $+55^{\circ}\text{C}$ .
- Stop using and contact the local dealer if the radio emits strange odor or smoke.
- Do not transmit without antenna installed, or the devices will be damaged.
- Please power off in flammable and explosive environment.
- Keep the radio at least 1 meter away from your vessel's magnetic navigation compass.
- The radio meets IPX7 waterproof requirement. However, once the radio has been dropped, waterproof protection cannot be guaranteed because of possible damage to the radio's sealed structure.
- Make sure the radio antenna, earphone jack cover and battery cover are dry before attachment. Or the radio inner components will be damaged.
- Do not put the battery into the water individually. Do not short-circuit the battery.

## ■ Suggestion

Clean the radio thoroughly with fresh water after exposure to salt water. Dry it before operating. Otherwise the radio keys and control components may be unusable due to salt crystallization.

DO NOT submerge the radio in water. The waterproof protection may not be effective if the rubber ring of battery cover or earphone jack cover is damaged in unexpected accident. Please contact with local dealer if they are damaged.

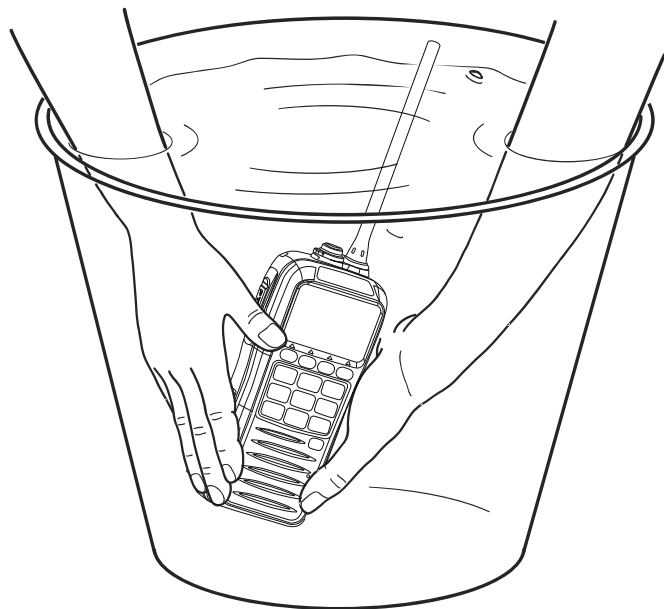

## ■ FEATURES

### ◆ Water-resistant Production

The radio water-resistant protection meets IPX7 requirements. Can be 1 meter depth in water for 30 minutes. Use the battery, earphone jack cover and antenna as configured. Make sure install well and tight.

### ◆ Float

The radio will float, make "Di Di..." alarm sound and send out flash alarm when drops into the water. The display indicates "WATER IS DETECTED".

The radio can float in fresh or salt water with the standard accessories - battery, belt clip and antenna.

When a third-party battery, belt clip and antenna etc. are used, the radio may sink and leak.

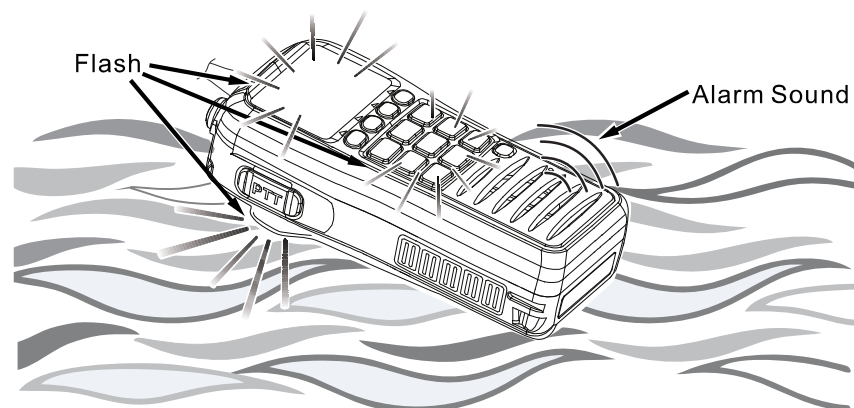

# CONTENTS

## PREPARATION

Supplied Accessories .....	1
Preparation .....	1
Charge the Battery Pack .....	1
Install/Remove Battery Pack .....	2
Install/Remove Antenna .....	3
Install Belt Clip .....	3
Install Earphone/Programming Cable .....	3

## GET ACQUAINTED

Appearance .....	4
Display Screen .....	5
Softkey .....	6
Select Softkey .....	6
Softkey Function .....	6

## BASIC OPERATION

Power ON/OFF .....	7
Adjust the Volume Level .....	7
Adjust the Squelch Level .....	7
Transmit and Receive .....	7
Select Channel Group .....	8
Select Channel.....	8
Channel 16 .....	8
CALL Channel.....	8
Weather Channel .....	8
Edit CALL Channel.....	9

Edit Channel Name .....	9
Monitor Function .....	10
Automatic Backlight .....	10
Key Lock .....	10
Vibration Water Draining Function .....	10

## SCAN OPERATION

Scan Types .....	11
Set TAG Channels .....	11
Set/Cancel Single TAG Channels .....	11
Set/Cancel All TAG Channels .....	11
Scan Operation .....	11

## DUAL WATCH/TRI-WATCH

Description .....	12
Operation .....	12

## DSC OPERATION

Set MMSI Code .....	13
DSC Setting .....	13
Program Position and Time .....	14
Program Individual ID .....	14
Program Group ID .....	14
Delete Individual/Group ID .....	15
Automatic Acknowledgement .....	15
Channel 16 Switch Function .....	16
Alarm .....	16

Channel 70 Squelch Level .....	16
DSC Loop Test .....	17
Channel 70 Watch Function .....	17
Distress Call .....	17
Simple Call .....	17
Regular Call .....	18
Cancel Distress Call .....	19
Receive Distress Call .....	20
Receive Distress Acknowledgement .....	20
Receive Distress Reply Call .....	21
Receive Distress Reply Acknowledgement .....	21
Individual Call .....	22
Transmit Individual Call .....	22
Receive Individual Call .....	23
Transmit Individual Acknowledgement .....	24
Group Call .....	25
Transmit Group Call .....	25
Receive Group Call .....	26
All Ships Call .....	26
Transmit All Ships Call .....	26
Receive All Ships Call .....	27
Geographical Area Call .....	28
Receive Geographical Area Call .....	28
Position Request Call .....	28
Transmit Position Request Call .....	28
Receive Position Request Call .....	29
Transmit Position Reply Call .....	30
Position Report Call .....	31

Transmit Position Report Call .....	31
Receive Position Report Call .....	32
Transmit Position Report Reply Call .....	33
Polling Request Call .....	34
Transmit Polling Request Call .....	34
Receive Polling Request Call .....	35
Transmit Polling Reply Call .....	35
Test Call .....	37
Transmit Test Call .....	37
Receive Test Call .....	38
Transmit Test Acknowledgement Call .....	38
Receive Test Acknowledgement Call .....	39
Received Call Log .....	40
Distress Message .....	40
Other Messages .....	40
Transmitted Call Log .....	41

## OTHER FUNCTIONS

MOB (Man OverBoard) .....	42
Store a MOB Point .....	42
Check the Stored MOB Point .....	42
Start Navigation to MOB Point .....	42
Edit MOB Point .....	43
Delete MOB Point .....	43
Waypoint .....	43
Store Position .....	43
Store Received Position .....	43
Check the Stored Waypoint .....	44
Sort the Waypoint .....	44

Navigation to Waypoint .....	44
Add Waypoint .....	44
Edit Waypoint .....	45
Delete Waypoint .....	45
Navigation .....	46
Navigation to MOB Point .....	46
Navigation to Waypoint .....	46
Navigation Interface Description .....	46
Compass Interface .....	47
GPS Status Interface .....	47
Sky View .....	47
Satellite Image .....	47
Satellite Signal Strength Interface Description .....	47

## MENU INTERFACE OPERATION

Menu Interface Operation .....	48
Enter Menu Interface Operation .....	48
Menu Items .....	48
Set Items .....	49
Scan Type .....	50
Scan Timer .....	50
Dual/Tri-Watch .....	50
Channel Group .....	50
Weather Alert .....	50
Configuration Items .....	50
Backlight .....	51
Display Contrast .....	51
Key Beep.....	51
Key Assignment .....	51

UTC Offset .....	51
Noise Cancel .....	51
Inactivity Timer .....	51
Float & Flash .....	51
Monitor .....	51
Unit .....	51

VHF MARINE CHANNEL LIST .....	52
SPECIFICATIONS .....	53
TROUBLESHOOTING.....	54

# PREPARATION

## ■ Supplied Accessories

Carefully unpack the radio. We recommend that you identify items listed in the following table before discarding the packing materials. If any item is missing or has been damaged, please contact the dealer immediately.

Items	Quantity
Antenna	1
Li-ion Battery	1
Desktop Charger (With Screws, Battery Bracket and Rubber Band)	1
AC Adaptor	1
Cigarette Lighter Cable	1
Belt Clip	1
Hand Strap	1
Instruction Manual	1

## ■ Preparation

### ◆ Charge the Battery Pack

#### Charge the radio with battery pack

1. Connect the adaptor output cable with desktop charger; then connect the adaptor with AC power.
2. Insert the radio with battery into desktop charger to charge. Confirm well connected.

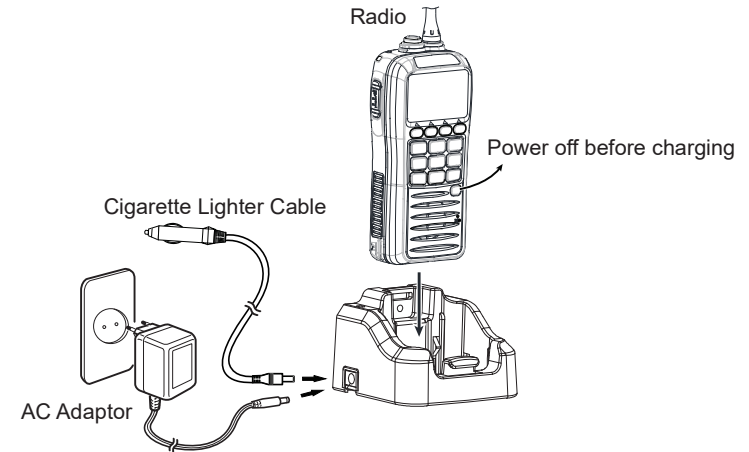

### Charge the battery pack individually

1. Connect the adaptor with desktop charger; then connect the adaptor with AC power.
2. Install the battery bracket into charging groove of desktop charger.
3. Insert single battery pack into desktop charger to charge.

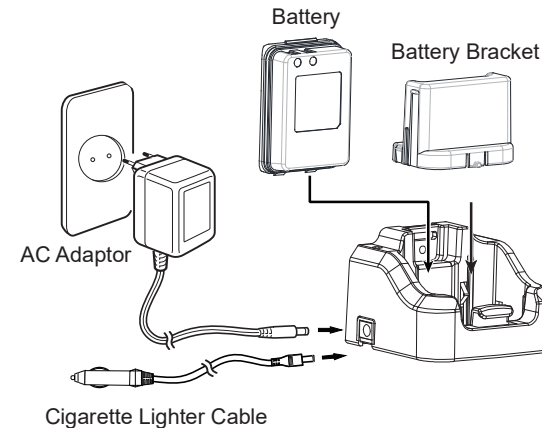

※ NOTE:

- The desktop charger can be fixed on table or wall by configured self-tapping screws. If select fix the desktop charger on wall, please fix the self-tapping screw 1 on wall first, then aim the hole of the charger back to the screw 1 and insert. Make sure the desktop charger insert tight and then lock screw 2.
- Power off before charging.
- The charging indicator light turns red while charging.
- The charging indicator light turns green while full charged.
- Please use the supplied cigarette lighter cable to charge.

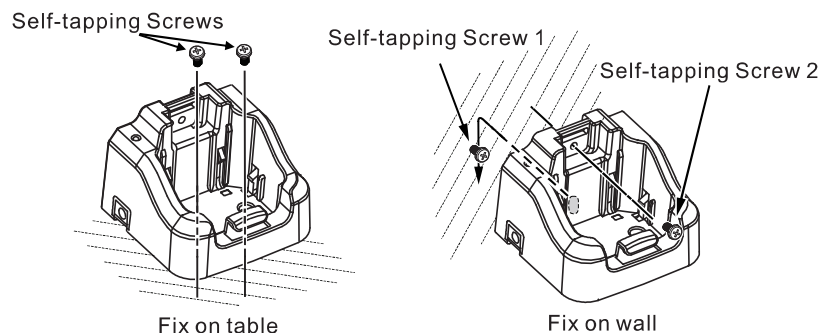

### Fix by rubber band

If the charging environment is shaky, use the rubber band to fix the radio or battery pack. Charging will be more reliable.

1. Use the rubber band cross through the whiffletree of desktop charger.
2. Insert the radio or single battery pack into desktop charger.
3. Use the rubber band cross through radio or battery and twine in the hanger.

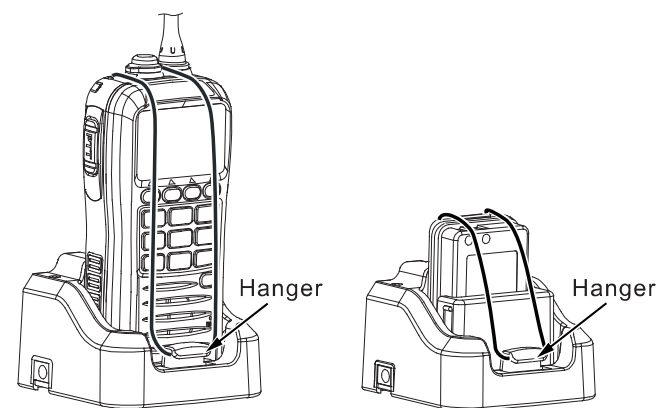
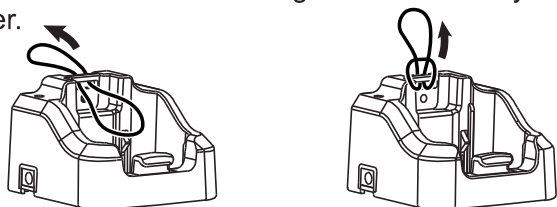

### ◆ Install/Remove Battery Pack

#### Install battery pack

1. Aim the battery terminal at radio power contact. Push the battery into groove.
  2. Press downward the battery. Make sure the battery clip into groove.
- It may cause water ingress if not well install the battery pack.

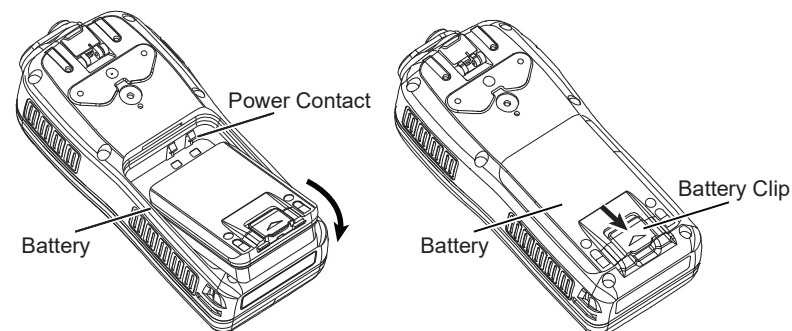

#### Remove battery pack

1. Push the battery clip upward.
2. Lift upward the battery bottom to remove battery pack.



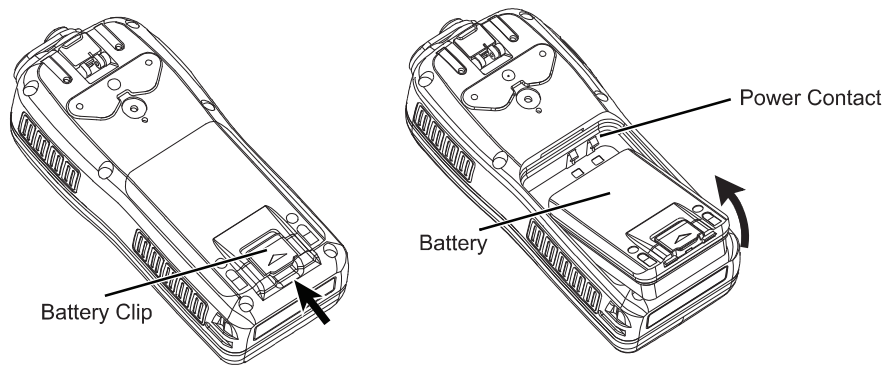

※ NOTE:

- Do not short-circuit the battery terminal or throw it into fire.
- Do not take apart the battery shell by yourself.

◆ Install/Remove Antenna

1. Connect the supplied fixable antenna to the antenna connector; rotate it clockwise until it is tight.
2. To remove it, rotate it counter clockwise.

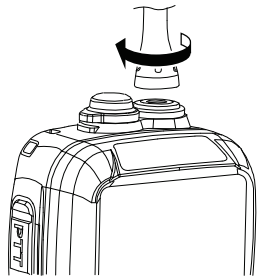

◆ Install Belt Clip

1. Attach the belt clip to radio rear cover. Ensure the screw holes are aligned.
2. Screw tightly using Phillips screwdriver.

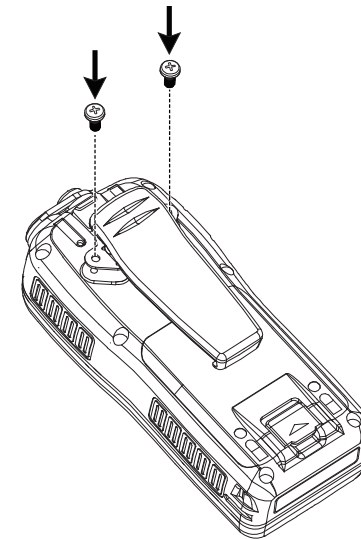

◆ Install Earphone/Programming Cable

1. Open the earphone/programming cable jack cover.
2. Aim the earphone/programming cable at jack. Rotate it tight.
3. Close the jack cover after using to protect the jack.

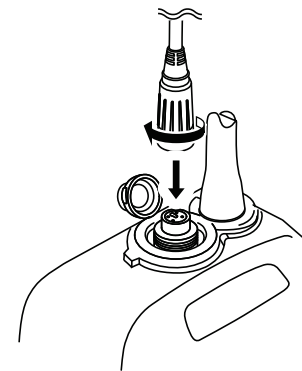

## GET ACQUAINTED

### ■ Appearance

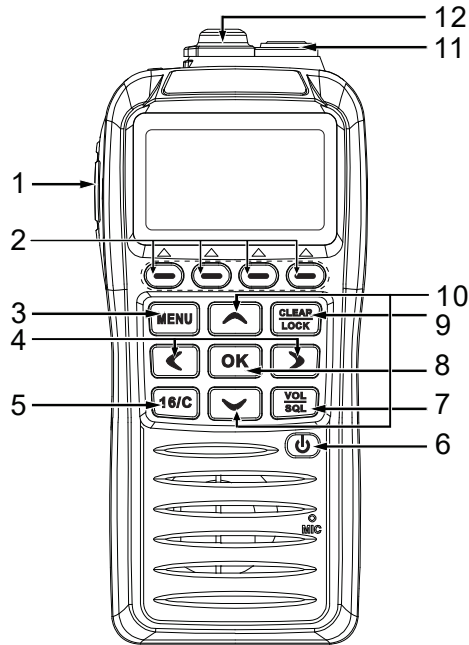

#### 1. [PTT]

- Hold down [PTT] to transmit. Speak with normal tone.
- Release [PTT] to receive.

#### 2. Softkey [—]

Press [◀]/[▶] to slide the menu in display screen bottom.  
Press these four keys [—] to select. See the Softkey on the next page for more details.

#### 3. [MENU]

Press [MENU] to enter or exit menu interface.

#### 4. [◀]/[▶]

Press [◀]/[▶] to switch softkey [—] corresponding menu functions.

#### 5. [16]/[C]

- Press this key to select CH 16.
- Hold on 1 second to select CALL Channel.
- The factory default for Call Channel is Channel 9.
- When the Call Channel is selected, hold for 3 seconds to enter the Call Channel programming mode.

#### 6. Power Key [⏻]

Hold down this key for 1.5 seconds to power on/off the radio.

#### 7. [VOL/SQL]

- In standby mode, press to enter the volume adjustment mode.
- When in volume adjustment mode, press again to enter the squelch adjustment mode.
- Hold for 1 second to active the Monitor Function.

#### 8. [OK]

Press to enter options and set inputting datas.

#### 9. [CLEAR/LOCK]

- Press to return to last interface or cancel the input data.
- Hold for 1 second to turn on or off lock function.

#### 10. [▲]/[▼]

- In standby mode, press to select operation channel.
- In menu mode to select menu and menu setting.
- While in channel scan, press to change the scan direction.

#### 11. Antenna Connector

Connect with 50Ω supplied antenna.

#### 12. [SP MIC]

To connect with optional earphone.

※ NOTE: Ensure the cover for the earphone jack is affixed tightly to avoid water ingress

## ■ Display Screen

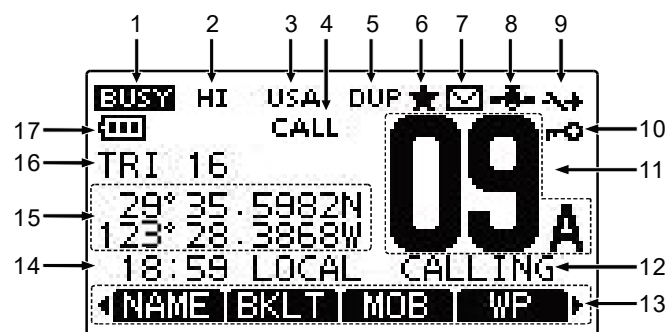

No.	Item	Description
1	Signal Status	<ul style="list-style-type: none"> <li>● BUSY appears while channel is busy.</li> <li>● TX appears while transmitting.</li> <li>● MONI appears while monitor signal is activated.</li> </ul>
2	Power	<ul style="list-style-type: none"> <li>● HI appears while transmitting in high power.</li> <li>● LOW appears while transmitting in low power.</li> </ul>
3	Channel Group	<ul style="list-style-type: none"> <li>● USA appears while USA Channel is selected.</li> <li>● INT appears while International Channel is selected.</li> <li>● CAN appears while Canadian Channel is selected.</li> <li>● WX appears while weather channel is selected.</li> </ul>
4	CALL Channel	<ul style="list-style-type: none"> <li>● CALL appears while CALL channel is selected.</li> </ul>
5	Duplex Channel	<ul style="list-style-type: none"> <li>● DUP appears while duplex channel is selected as operation channel.</li> </ul>
6	TAG channel	<ul style="list-style-type: none"> <li>● ★ appears when TAG channel is selected as operation channel.</li> </ul>
7	Message	<ul style="list-style-type: none"> <li>● ✉ flashes while there is unread messages.</li> </ul>
8	GPS	<ul style="list-style-type: none"> <li>● GPS appears while GPS data and valid position information is received.</li> <li>● GPS flashes while invalid position information is received.</li> </ul>

No.	Item	Description										
9	Power	<ul style="list-style-type: none"> <li>● Appears when "CH 16 SWITCH" is OFF in DSC menu.</li> </ul>										
10	Key Lock	<ul style="list-style-type: none"> <li>● Appears when key lock.</li> </ul>										
11	Channel Number	<ul style="list-style-type: none"> <li>● Indicates operation channel number.</li> <li>● "A" appears when the TX and RX frequencies in selected channel is the same.</li> </ul>										
12	Channel Name	<ul style="list-style-type: none"> <li>● Indicates channel name.</li> <li>● "DSC CHECK" flashes while receiving signals in CH70.</li> </ul>										
13	Softkey	<ul style="list-style-type: none"> <li>● Indicates the programmed function of the softkeys on the front panel.</li> </ul>										
14	Time Zone Indicator	<ul style="list-style-type: none"> <li>● Indicates the current time when GPS data is received or the manually programmed time.</li> <li>● "??" flashes while invalid GPS data is received over 30 seconds.</li> <li>● "??" flashes while manually input GPS data is invalid after 4 hours, and "NO TIME" appears after 23.5 hours.</li> <li>● "LOCAL" appears while the offset time is set.</li> <li>● "NO TIME" appears while no GPS data is received and no time data is manually input.</li> <li>● "MNL" appears while time is manually programmed.</li> </ul>										
15	Position Indicator	<ul style="list-style-type: none"> <li>● Indicates the current position while valid GPS data is received or the position is manually input.</li> <li>● " ?? " flashes while invalid GPS data is received over 30 seconds.</li> <li>● " ?? " flashes while manually input GPS data is invalid after 4 hours, and "NO TIME" appears after 23.5 hours.</li> <li>● "NO POSITION" appears while no GPS data is received after power on.</li> <li>● "NO POSITION" appears when no GPS data is received or no position is manually input.</li> </ul>										
16	Scan Indicator	<ul style="list-style-type: none"> <li>● "SCAN 16" appears during priority scan. "SCAN" appears during normal scan.</li> <li>● "DUAL 16" appears during dual watch. "TRI 16" appears during tri-watch.</li> </ul>										
17	Battery Indicator	<ul style="list-style-type: none"> <li>● Indicate the battery remaining power.</li> </ul> <table border="1"> <thead> <tr> <th>Indication</th> <th></th> <th></th> <th></th> <th></th> </tr> </thead> <tbody> <tr> <td>Battery Level</td> <td>Full</td> <td>Middle</td> <td>Charging Required</td> <td>No Power</td> </tr> </tbody> </table>	Indication					Battery Level	Full	Middle	Charging Required	No Power
Indication												
Battery Level	Full	Middle	Charging Required	No Power								

## ■ Softkey

Several functions can be assigned to the softkeys. When the key function is assigned, the key is displayed above the softkeys. Shown as below.



※NOTE: The key order may be different from above picture. It can be set by programming software.

### ◆ Select Softkey

Press [◀]/[▶] to switch corresponding [—] softkey. When the key shows "◀" or "▶", press [◀]/[▶] to sequentially displayed all softkey functions.

### ◆ Softkey Function

The softkey function can achieve below functions.

1. **SCAN**  
Press this key to turn ON/OFF normal scan or priority scan.
2. **DW**  
Press this key to turn ON/OFF dual watch or tri-watch.
3. **HT/LP**  
Press this key to select high power or low power. Some channel is set as low power and cannot be changed.
4. **CH/WX**  
Press this key to select normal channel or weather channel.

5. **VIB**  
Press this key to turn on vibration draining function. The microphone will emit sounds and drain the water from the microphone housing.
6. **★**
  - Press this key to set the current channel as TAG channel; Press again to clear TAG channel.
  - Press and hold this key for 3 seconds to clear or set all TAG channels at the current channel group.※NOTE: The TAG channel is also called as favorite channel.
7. **NAME**  
Press this key to enter channel name edit mode.
8. **BKLT**  
Press this key to enter display screen and keypad backlight adjustment mode. Then press [▲]/[▼]/[◀]/[▶] to adjust display screen and keypad backlight.
9. **MOB**
  - Press this key to enter "MOB" alarm interface.
  - Press and hold this key for 1 second to store the current position as MOB.
10. **WP**
  - Press this key to enter "WAYPOINT" interface.
  - Press and hold this key for 1 second to store the current position as one waypoint.
11. **NAV**  
Press and hold [MOB], or in the MOB, WAYPOINT interface, press this key to navigate the selective position.
12. **COMP**  
Press this key to display ship course, speed over ground (SOG) and course over ground (COG).
13. **LOG**  
Press this key in DSC call interface to enter "Receive LOG Call".

## BASIC OPERATION

### ■ Power ON/OFF

1. Press and hold (🔌) for 1 second to power on. Enter the normal operation mode.
2. Press and hold (🔌) for 1 second to power off.

### ■ Adjust the Volume Level

The volume level can be adjusted by [VOL/SQL] and [▲]/[▼]/[◀]/[▶] keys.

1. Press [VOL/SQL] to enter volume adjustment mode. Then press [▲]/[▼]/[◀]/[▶] to adjust volume level.
  - "VOL" appears.
  - The radio has 20 volume levels. OFF is closed.
  - If no operation is performed for 5 seconds, the radio will return back to normal operation mode automatically.
2. Press [OK] to set or exit volume adjustment mode.
  - Press [CLEAR] to cancel.

### ■ Adjust the Squelch Level

The squelch level can be adjusted by [VOL/SQL] and [▲]/[▼]/[◀]/[▶] keys. In order to receive better signals and valid scan, the squelch level should be adjusted properly.

1. Press [VOL/SQL] to enter volume adjustment mode. Then press [▲]/[▼]/[◀]/[▶] to adjust volume level.
  - The screen flashes "SQL".
  - If no operation is performed for 5 seconds, the radio will return back to normal operation mode automatically.
  - The radio has 11 squelch levels. OPEN is completely open. 10 is the maximum squelch level.

2. Press [OK] to set or exit squelch adjustment mode.
  - Press [CLEAR] to cancel.

### ■ Transmit and Receive

1. Press [HI/LO] to select transmit power.
  - "HI" appears while high power is selected. "LO" appears while low power is selected.
  - Select low power for short range communication. Select high power for long range communication.
  - Some channels are only for low power transmit.
2. Press and hold [PTT]. Speak to the microphone to transmit.
  - "TX" appears.
  - Channel 70 cannot be used for normal transmission.
3. Release [PTT] to receive.
  - "BUSY" appears while receiving signals. The sounds come from microphone.

#### ※ NOTE:

- The radio may be damaged if not install the antenna.
- The radio will monitor Channel 70 every specific time even when standby on operating channel.
- "DSC CHECK" appears when Channel 70 is busy.
- The Channel 70 monitor configuration can be changed in DSC setting.
- The radio has time-out timer (TOT) function. It will stop automatically after continuous transmission for 5 minutes.
- Hold the microphone 5-10cm from the mouth while speaking.
- The power save function is activated while no signal is received for 5 seconds.

## ■ Select Channel Group

This radio contains USA Channel, International Channel and Canadian Channel. Choose the appropriate channel groups in your operating area.

1. Press [MENU].
2. Press [▲]/[▼] to select "Radio Setting".
3. Press [▲]/[▼] to select "CHAN Group" and then press [OK].
4. Press [▲]/[▼] to select desired channel group and then press [OK].
5. Press [EXIT] to exit menu interface.
6. Press [▲]/[▼] to select channel.
  - "DUP" appears while duplex channel is selected.
  - "A" appears while simplex channel is selected.

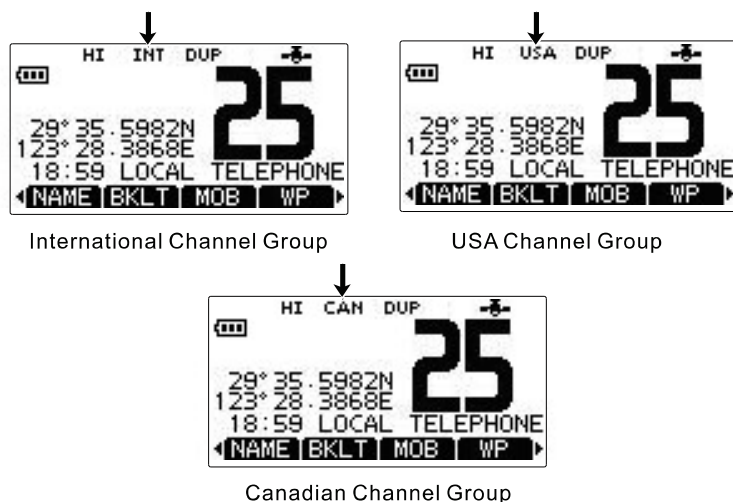

## ■ Select Channel

### ◆ Channel 16

Channel 16 is distress and safety channel. It is used for establishing initial contact with a station and for urgent communications. Channel 16 is monitored during dual watch and tri-watch.

1. Press [16/C] to select Channel 16.

2. Press [CH/WX] to return to the selected channel before Channel 16. Press [▲]/[▼] to select operating channel.

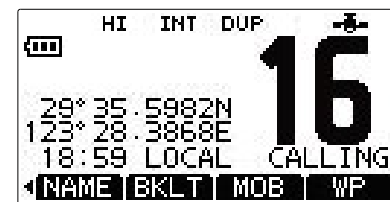

### ◆ CALL Channel

Every channel group has a CALL channel. The CALL channel is monitored by tri-watch. The factory default for CALL channel is Channel 9. It can be reprogrammed.

1. Press and hold [C/16] for 1.5 seconds to select the CALL channel in the current channel group. "CALL" and call channel number appears.
2. Press [CH/WX] to return to the CALL channel before selected operating channel. Or press [▲]/[▼] to select other operating channel.



### ◆ Weather Channel

This radio has 10 weather channels.

The radio can detect a weather alert sound automatically in the selected weather channel while receiving and scanning.

#### Select Weather Channel

Press [CH/WX] to select weather channel or normal channel.



- "WX" appears while weather channel is selected.
- "WX☞" appears while weather alert is turned on.



### Set Weather Alert

1. Press [MENU].
2. Press [▲]/[▼] to select "Radio Settings" and then press [OK].
3. Select "WX Alert" and then press [OK].
4. Select "ON" or "ON with Scan" to set weather alert.
5. Press [EXIT] to exit menu interface.
  - "WX☞" appears for weather alert.

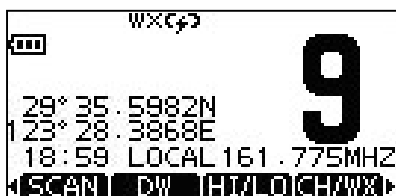

## ■ Edit CALL Channel

A CALL Channel can be edited in each channel group. The factory default is Channel 9.

1. Select a desired programmed channel group (USA, International or Canadian).
2. Press and hold [16/C] for 1 second to select CALL Channel.
  - "CALL" and CALL channel number appear.
3. Press and hold [16/C] for 3 seconds until a long "BEEP" sound and two short "DUDU" sound are heard to enter CALL channel programming mode.
  - Enter CALL channel programming mode interface.

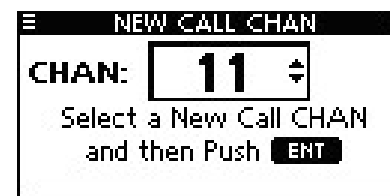

4. Press [▲]/[▼] to select desired channel.
5. Press [OK] to confirm current channel setting as CALL channel.
  - Return to normal operating mode automatically.



## ■ Edit Channel Name

Each channel can be assigned a unique name up to 10 characters. 26 capital letters, 0-9, symbols (! " # \$ % & ' ) \* + , - . \ [ ] ^ \_ ; < = > ?) and space can be input.

1. Press [▲]/[▼]/[◀]/[▶] to select a channel.
  - Cancel dual watch, tri-watch and scan function first.
2. Press [NAME] to open channel name edit interface.
  - A black frame is indicated on the first character.
3. Edit the desired channel name by the following ways.
  - Press [▲]/[▼]/[◀]/[▶] to select desired characters.
  - Press [OK] to confirm.
  - Move the cursor, select "←" or "→" and then press [OK].
  - Select "SPACE", then press [OK] to input a space.
  - Select "DELETE", then press [OK] to delete a character.
  - Press [CLEAR] to cancel and return to the last interface.

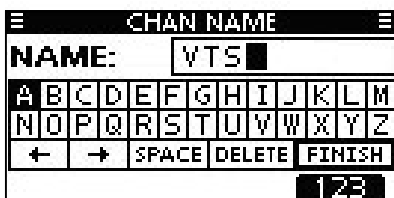

4. Repeat Step 3 to input all characters.

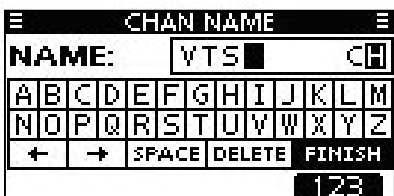

5. Press [▲]/[▼]/[◀]/[▶] to select "FINISH". Then press [OK] to set and return to the last interface.

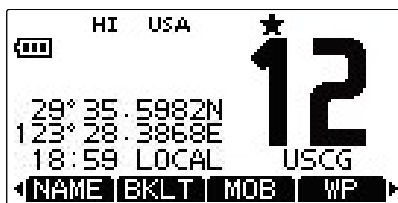

## Monitor Function

Press and hold [VOL/SQL] for 1 second to open monitor function.

- " **MONI** " appears while this function is activated.

This function can be set to "PUSH" or "HOLD" in the following ways.

1. Select "Configuration" in the "MENU".
2. Select "MONI" to enter "PUSH" or "HOLD" selecting mode.
  - PUSH: The monitor function is activated by holding [VOL/SQL] for 1 second. The squelch keeps opened while holding [VOL/SQL]; closed while releasing.
  - HOLD: The monitor function is activated by holding [VOL/SQL] for 1 second. The squelch keeps opened while holding [VOL/SQL]; closed while pressing any key.

## Automatic Backlight

The automatic backlight function is convenient for night operation. This function can be turned ON/OFF in the set mode.

1. Select [BKLT] to enter backlight adjustment mode.
2. Press [▲]/[▼]/[◀]/[▶] to select backlight brightness level between 1 to 7 or OFF.
  - The factory default for brightness is level 4.
  - The backlight is automatically turned OFF after 5 seconds without operation.

## Key Lock

This function can lock all keys except [PTT], [DISTRESS] and [⏻] to prevent accidental operation of channel and function changes.

- Press and hold [LOCK] for 1 second to turn ON/OFF the key lock function.
- The key lock function is automatically released while DSC call is received or [DISTRESS] is pressed.

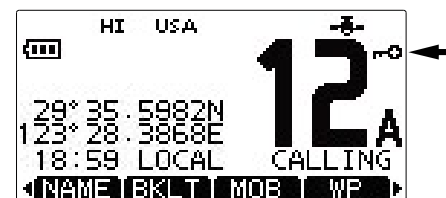

## Vibration Water Draining Function

The vibration water draining function helps to drain the water away from the loudspeaker housing. It can prevent water ingress to affect the loudspeaker voice quality. The radio emits a vibrating sound while this function is activated.

- Press or hold [VIB] to activate vibration water draining function.
- A deep sound emits for 5 seconds to drain water.
- Any key operation is invalid while vibration water draining is activated.
- The vibration water draining function is invalid while connecting with external speaker microphone.



# SCAN OPERATION

## ■ Scan Types

The scan types including normal scan and priority scan, can be selected in the set mode (Please refer to set mode operation).

The weather channel will be scanned also if the weather alert function is activated.

Set TAG channels before scanning. Cancel TAG for channels not need to be scanned.

Normal scan: Scan TAG channels. Channel 16 won't be scanned if it is not set as TAG channel.

Priority scan: Scan Channel 16 during normal scan.

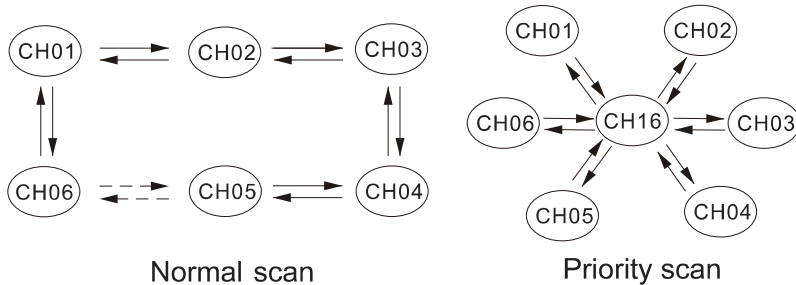

## ■ Set TAG Channels

Set TAG (★) for channels need to be scanned. Cancel TAG (★) which is no need. The untaged channels will be skipped during the scan period.

### ◆ Set/Cancel Single TAG Channel

1. Select the desired channel group.
2. Press [▲]/[▼] to select the desired TAG channel.
3. Press [★] to set the current channel as TAG channel.
  - "★" appears on display.
4. Press [★] again to cancel the TAG channel.
  - "★" disappears on display.

### ◆ Set/Cancel All TAG Channels

1. Press and hold [★] for 3 seconds to clear all the TAG channels at the current channel group.
2. Press and hold [★] again for 3 seconds to set all the current channels as TAG channel.

## ■ Scan Operation

Set scan types, weather alert function and scan resume timer in the menu interface.

1. Press [SCAN] to start normal scan or priority scan.
  - "SCAN 16" appears during priority scan. "SCAN" appears during normal scan.
  - The scan pauses when a signal is received. The scan continues until signal disappear or pause for 5 seconds.
  - Channel 16 is monitored in priority scan. "16" flashes and a "beep" sound emits when a signal is received in Channel 16.
  - Press [▲]/[▼] to change the scan direction.
2. Press [CLEAR] to stop scan. Or press [SCAN] or [PTT].



## DUAL WATCH/TRI-WATCH

### ■ Description

This radio contains dual watch/tri-watch function, can be selected in the set mode.

Dual watch: Watch and monitor in turns between the current channel and Channel 16.

Tri-watch: Watch and monitor in turns among the current channel, Channel 16 and CALL Channel.

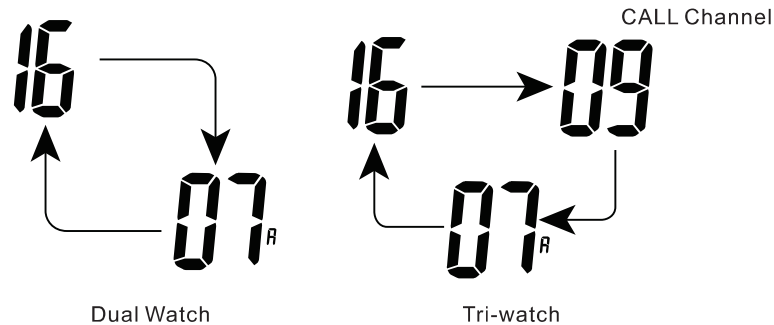

### ■ Operation

1. Press soft key [DW] to start dual/tri-watch.
  - "DUAL 16" appears during dual watch; "TRI 16" appears during tri-watch.
  - A "beep" sound emits when signal is received in Channel 16.
  - Tri-watch switches to dual watch when signal received in CALL Channel.
2. Press [DW] again to cancel.

