

# RETAVIS

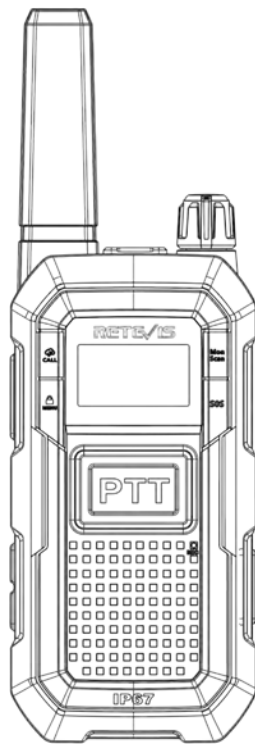

**RB48**  
USER'S MANUAL

## Contents

Warning	01
Notes of charging	01
Radio introduction	02
LCD Display	02
Function operation	03
Technical Specifications	05
Default Frequency	06
WARNING	07

For downloading further resources:  
Brochures, Software/Firmware, Manual etc, Pls contact  
your direct reseller first OR go to website [retevis.com](http://retevis.com) and  
check "support" in the each product link to download it.

### **Warning**

Please read this manual carefully before using this radio.  
Please do not charge the radio in flammable, explosive and areas which radio communication are prohibited (such as oil station, gas station, airport etc.)  
Please do not operate this radio in government laws banned areas  
Please make sure this radio avoids the sunshine, and avoids placing it near any heating device.  
If radio has a smell or smokes, please remove the battery pack from radio immediately, then contact your nearest distributor.  
The repair job of this radio is in the charge of professionals & technical's, self-disassembly is prohibited.

### **Notes of charging:**

Please use the matching charging base or Type-C charging cable to charge.  
Please make sure the radio is turned off when charging.  
In order to get the best battery performance, please charge for at least 5 hours for the first time.  
Please do not charge the battery for a long time, otherwise the service life of the battery will be shortened. When the battery is fully charged, please stop charging in time.  
The charger is only charged for this radio battery, please do not charge other battery, otherwise it will cause damage to the charger and battery.  
After the battery is fully charged, please place it in a cool, dry place. Please do not get close to fire or expose to sunlight, otherwise there will be a safety hazard.  
During the radio charging, it is not recommended to transmit.  
During the radio charging, the battery will be slightly hot, which is normal.

## Radio introduction

1. Antenna
2. Call tone for short press  
(need to select the type of call tone)  
NOAA for long press (US version)
3. PTT
4. Short press to enter the menu function  
Long press to open the key lock (US version)
5. Up
6. Down
7. Earpiece Jack
8. Volume/Power Switch
9. LED display
10. Short press to switch scan function  
(It needs to click the scan function in the software)  
Long press to switch monitor
11. Alarm
12. PTT
13. Type-c

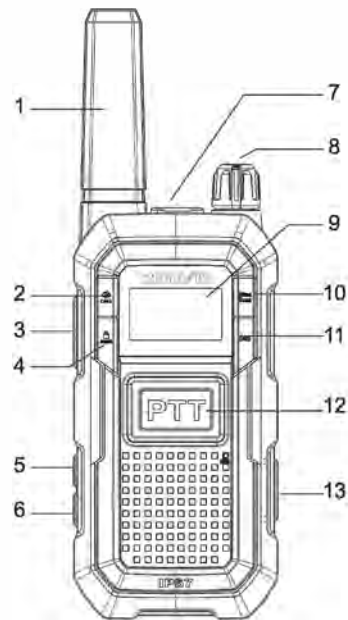

## LCD Display

1. NOAA Weather
2. Battery power
3. Scan
4. High Power
5. Lock

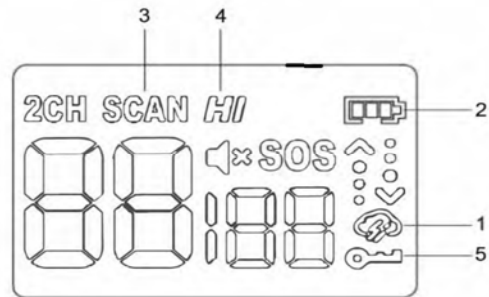

## Function operation

### 1. Turn on/off

1.1 Turn the power switch clockwise to turn on the radio, the radio will sound a power-on prompt and all icons will be displayed in full screen when the radio is turned on. After the radio is turned on, the default mode of the radio is in direct call mode, displaying the currently used channel and CTC/DCS, etc.

1.2 When turning off the radio, turn the power switch counterclockwise until a click sounds.

### 2. Volume adjustment

In standby or receiving state, turn clockwise to increase the volume, counterclockwise to decrease the volume, 1-9 levels of volume can be adjusted cyclically.

Note:

When the volume is not adjusted to a suitable state, please do not put the radio speaker too close to the ear to avoid the sound being too loud and hurting the hearing.

### 3. Transmit/Receive

3.1 In standby mode, press and hold the transmit button [PTT] to speak. When the transmit icon is displayed, it means that the call is being sent. To avoid cutting off your call content, please press the [PTT] key for a short pause, and then start speaking.

3.2 Release the transmit button [PTT] can receive the signal sent from the same channel, the speaker emits the call sound, and when receiving, the receive icon will be displayed.

Note:

1) When the radio is transmitting, please keep the radio in a vertical position and keep the microphone 3-5cm away from the mouth. When transmitting, please keep the radio at least 3 cm from the head or body.

2) During use, there is no need to perform multiple power-on and power-off actions, and at the same time adjust the volume to a volume suitable for your hearing.

3) Before calling on radio, please set the frequency of the transmitter and receiver to the same.

4) Please set the CTC/DCS of the transmitter and receiver for the channel you want to talk to be the same.

### 4. Set the channel

4.1 In the standby state of direct call mode, press the [MENU] key once, the current channel will flash.

4.2 Press [▲] or [▼] key to select the channel you want to set.

4.3 Press the [PTT] key to save the current setting and exit the menu or press the [MENU] key to jump to the next menu setting.

4.4 The radios can only communicate when they are set to the same channel, and the sound is clear, no noise.

### 5. CTC/DCS selection

This product supports a total of 121 groups of CTC/DCS, 38 groups of analog sub-tone codes and 83 groups (N-phase and I-phase) digital sub-tone codes can be set through software (CPS).

5.1 In the standby state of direct call mode, press the [MENU] key twice, the current CTC/DCS setting will flash.

5.2 Press [▲] or [▼] key to select the CTC/DCS you want to set. Press and hold the [▲] or [▼] key to quickly switch the CTC/DCS.

5.3 Press the [PTT] key to save the current setting and exit the menu or press the [MENU] key to jump to the next menu setting.

### 6. High/low power setting

6.1 In the standby state of direct call mode, press the [MENU] key 5 times, and "Pr" will be displayed on the screen.

6.2 Press [▲] or [▼] key to select power LO or HI. (LO: low power / HI: high power)

6.3 Press [PTT] key to save the current setting and exit the menu

### 7. TOT function

When you press and hold the [PTT] key continuously to talk for more than 15-600 seconds, the radio will emit a continuous warning tone, the radio will stop transmitting automatically.

### 8. Set Call Tone

8.1 In the standby state of direct call mode, press the [MENU] key 3 times, the setting screen of the current call tone will flash "CA".

8.2 Press [▲] or [▼] key to select the call tone you want to set, and the radio speaker will emit the corresponding call tone at the same time.

8.3 Press the [PTT] key to save the current setting and exit the menu or press the [MENU] key to jump to the next menu setting.

Note: When the call tone menu setting is selected as 0, the call function will be invalid when long press the [CALL] key.

### 9. Roger Beep

This product supports the Roger Beep function, which can send a sound to remind the receiver that the transmission has ended.

9.1 In the standby state of direct call mode, press the [MENU] key 7 times, and "rb" will be displayed on the screen.

9.2 Press[▲]or[▼]key to select ON and OFF

9.3 Press[PTT]key to save the current settings and exit the menu

9.4 After the function is turned on, there will be a prompt tone after the radio is finished transmitting.

**10. Button Function**

10.1 [SOS] key: long press this key to turn on the alarm function, press the PTT key to stop

10.2[CALL] key: long press this key to switch between direct call and NOAA weather mode; short press this key to transmit call tone

10.3 [SCAN] key: long press this key to start listening; short press this key to start scanning

10.4 [MENU] key: long press this key to operate the lock or unlock function; short press this key to enter or exit the menu

10.5[▲]key: short press up

10.6[▼]key: short press down

10.7[PTT] key : transmit or save settings (in menu mode)

**11. key lock function**

The keyboard lock function is to prevent users from misoperation when they do not want to change the settings of the radio.

11.1 Press and hold the [MENU] key until the lock icon appears to enter the keyboard lock state.

11.2 Press and hold the [MENU] key until the lock icon disappears to exit the keyboard lock state.

Note: When the keyboard is locked, a key failure tone will be emitted when any key is pressed except for the [PTT] key.

**12. channel scan**

12.1 In the standby state, press the [MENU] key 6 times, and the screen will display "SC".

12.2 Press[▲]or[▼]key to select ON and OFF

12.3 Press[PTT]key to save the current setting and exit the menu

12.4 The scanning function of the radio to scans the channels with valid signals, you can easily scan all channels

Note: When the scan menu setting is selected as OF, the scan function will be invalid when pressing the [SCAN] key.

**13. Start scan:**

13.1 Press the [SCAN] key in standby mode of direct call mode to enter the scan mode, the channel number will be displayed in an upward increment, and the [SCAN] icon will be displayed on the LCD.

13.2 When an active channel is detected, the radio automatically pauses to receive signals on this channel until the signal disappears. After the signal disappears for 5 seconds, the radio will continue to scan.

13.3 During the scanning process, press the [PTT] key, the radio will stop on the channel that entered the scan and transmit. If a valid signal is detected, the scan will stop and receive the signal, press the [PTT] key and the radio will transmit on the current channel scanned. After releasing the [PTT] key for 5 seconds, the radio will continue to scan

13.4 Press the [SCAN] key again to exit scan and return to the radio standby mode.

**14. Battery power display and low battery warning**

The battery icon shows the power level, from full to empty (0). When the power level is 0, the user is prompted to charge in time, accompanied by a low battery reminder (once every 30 seconds). When the battery power is low, the radio will be turned off.

Note: When the radio is not used for a long time, you need to charge the radio from time to time.

**16. Caller Vibration**

- 16.1 In the standby state of direct call mode, press the [MENU] key 8 times, and the screen will display "U1".
- 16.2 Press[▲]or[▼]key to select ON and OFF
- 16.3 Press[PTT]key to save the current settings and exit the menu
- 16.4 After the function is turned on, the first incoming call in standby mode will vibrate to indicate

**17. Power saving function**

The radio has unique features to extend battery life. If there is no call or voice received within 10 seconds, the radio will automatically enter power saving mode. The radio can still receive in this mode.

**18. NOAA Weather**

The NOAA weather function is available in the U.S. and Canada as needed.

You can listen to the NOAA Weather Channel (For details, please refer to "the NOAA Weather Channel and Frequency" list). You cannot in scan mode or use radio communication when you need to listen to the NOAA Weather Channel

NOAA and Environment Canada both have transmitters throughout the U.S. and Canada. These transmitters broadcast 24 hours a day with forecasts and other information.

**19. Enter NOAA Weather Mode**

In direct call mode, press and hold the [CALL] button for 1 second to enter the NOAA weather mode.

Set the NOAA weather channel

Your radio receives NOAA weather frequencies:

- 19.1 In NOAA weather mode, press the [MENU] button until the NOAA weather channel number flashes.
- 19.2 Press the [▲] or [▼] button to select a suitable channel with good reception in your area.
- 19.3 Long press the [CALL] button to exit the menu.

**20. Set NOAA Weather Alerts**

Your radio can be set to respond to NOAA weather broadcast emergencies. A special alarm tone will sound the alarm and turn on the weather receiver to provide you with instant weather and emergency information.

20.1 In NOAA weather mode, press the [MENU] button twice, the weather forecast icon will be displayed.

20.2 Press[▲]or[▼]button to select ON/OFF.

20.3 Press the [MENU] button to exit the weather setting.

20.4 Press and hold the [CALL] button for 1 second to return to the direct call mode, if you turn on the NOAA weather alert and return to the direct call mode, the weather forecast icon will be displayed.

Note: After entering the NOAA weather channel, if you receive an alarm, press and hold the [CALL] button for 1 second, the NOAA weather mode will automatically return to channel mode

**21. Headset function**

21.1 Connect the headset accessories to the radio (radio A&B).

21.2 Press the [PTT] button on the headset of the radio A, sending a call to the MIC of the headset, and the radio B should be able to receive it normally. Repeat the same operation on radio B.

**Technical Specifications**

General	Frequency Range	FRS
	Channel Capacity	22
	Channel step value	12.5KHz
	Operation Voltage	3.7V
	Battery Capacity	2000mAh(Li-Ion)
	Operating Temperature	-20 C +60 C
	Antenna Impedance	50Ω
	Dimensions	180*60*33mm (with antenna)
Transmitter	Output Power	High: 2.0W Low: 0.5W
	Frequency Stability	±2.5ppm
	Adjacent Channel Power	60dBm@12.5KHz
	FM Modulation	12.5KHz@11K0F3E

Receiver	Transmission current	≤1500mA
	Analog receive sensitivity	0.25uV/-119dBm(20dB SINDA)
	Audio Power	≥300mW
	Rated Audio Distortion	≤3%
	Receive current	≤410mA

**Default Frequency**  
[FRS]22CH

CH NO.	Frequency(MHz)	Power
1	462.5625	2W
2	462.5875	2W
3	462.6125	2W
4	462.6375	2W
5	462.6625	2W
6	462.6875	2W
7	462.7125	2W
8	467.5625	0.5W
9	467.5875	0.5W
10	467.6125	0.5W
11	467.6375	0.5W
12	467.6625	0.5W
13	467.6875	0.5W
14	467.7125	0.5W
15	462.5500	2W
16	462.5750	2W
17	462.6000	2W
18	462.6250	2W
19	462.6500	2W
20	462.6750	2W
21	462.7000	2W
22	462.7250	2W

**NOAA Weather channel and frequency**

Channel	Frequency	Channel	Frequency
WX1	162.550MHz	WX7	162.525MHz
WX2	162.400MHz	WX8	161.650MHz
WX3	162.475MHz	WX9	161.775MHz
WX4	162.425MHz	WX10	161.750MHz
WX5	162.450MHz	WX11	162.000MHz
WX6	162.500MHz		



## RF ENERGY EXPOSURE AND PRODUCT SAFETY GUIDE FOR TWO-WAY RADIOS

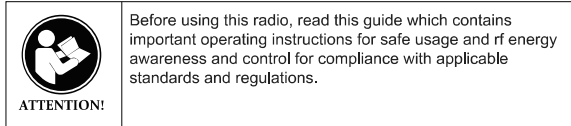

- User instructions should accompany the device when transferred to other users.
- Do not use this device if the operational requirements described herein are not met.

This two-way radio uses electromagnetic energy in the radio frequency (RF) spectrum to provide communications between two or more users over a distance. RF energy, which when used improperly, can cause biological damage.

All Retevis two-way radios are designed, manufactured, and tested to ensure they meet government-established RF exposure levels. In addition, manufacturers also recommend specific operating instructions to users of two-way radios. These instructions are important because they inform users of RF energy exposure and provide simple procedures on how to control it.

Please refer to the following websites for more information on what RF energy exposure is and how to control your exposure to assure compliance with established RF exposure limits: <http://www.who.int/en/>  
When two-way radios are used as a consequence of employment, the Local Government Regulations requires users to be fully aware of and able to control their exposure to meet occupational requirements. Exposure awareness can be facilitated by the use of a product label directing users to specific user awareness information. Your Retevis two-way radio has a RF Exposure Product Label. Also, your Retevis user manual, or separate safety booklet includes information and operating instructions required to control your RF exposure and to satisfy compliance requirements.

### Radio License(only applicable to licensed radio)

Governments keep the radios in classification, business two-way radios operate on radio frequencies that are regulated by the local radio management departments (FCC, ISED, OFCOM, ANFR, BFTK, Bundesnetzagentur...). To transmit on these frequencies, you are required to have a license issued by them. The detailed classification and the use of your two radios, please contact the local government radio management departments.

Use of this radio outside the country where it was intended to be distributed is subject to government regulations and may be prohibited.

### Unauthorized modification and adjustment

Changes or modifications not expressly approved by the party responsible for compliance may void the user's authority granted by the local government radio management departments to operate this radio and should not be made. To comply with the corresponding requirements, transmitter adjustments should be made only by or under the supervision of a person certified as technically qualified to perform transmitter maintenance and repairs in the private land mobile and fixed services as certified by an organization representative of the user of those services.

Replacement of any transmitter component (crystal, semiconductor, etc.) not authorized by the local government radio management departments equipment authorization for this radio could violate the rules.

### FCC Requirements:

This device complies with part 15 of the FCC Rules. Operation is subject to the condition that this device does not cause harmful interference. (Licensed radios are applicable);

This device complies with part 15 of the FCC Rules. Operation is subject to the following two conditions: (Other devices are applicable)

- (1) This device may not cause harmful interference, and
- (2) this device must accept any interference received, including interference that may cause undesired operation.

### (Only Applicable to GMRS radio station):

A valid individual license is required to operate a GMRS station. To obtain an individual license, an applicant must be eligible and follow the applicable rules and procedures established by FCC. The applicant must pay the required application and regulatory fees. Each individual license in the GMRS will normally have a term of ten years from the date of grant or renewal, and may be renewed pursuant to the procedures of FCC. To obtain a

GMRS operator license, you need FCC Form 605 & 159, we suggest visiting the FCC website at <https://www.fcc.gov/wireless/support/fcc-form-605>, which includes necessary instructions. More questions about the license application, please contact the FCC at 1-888-225-5322 or go to the FCC's website: <http://www.fcc.gov>. According to FCC rules, any individual who holds an individual license may allow his or her immediate family members to operate his or her GMRS station or stations. Immediate family members are the licensee's spouse, children, grandchildren, stepchildren, parents, grandparents, stepparents, brothers, sisters, aunts, uncles, nieces, nephews, and in-laws.

\*(Only applicable to industrial environment) This equipment has been tested and found to comply with the limits for a Class A digital device, pursuant to part 15 of the FCC Rules. These limits are designed to provide reasonable protection against harmful interference when the equipment is operated in a commercial environment. This equipment generates, uses, and can radiate radio frequency energy and, if not installed and used in accordance with the instruction manual, may cause harmful interference to radio communications. Operation of this equipment in a residential area is likely to cause harmful interference in which case the user will be required to correct the interference at his own expense.

\*(Only applicable to home) This equipment has been tested and found to comply with the limits for a Class B digital device, pursuant to part 15 of the FCC Rules. These limits are designed to provide reasonable protection against harmful interference in a residential installation. This equipment generates, uses and can radiate radio frequency energy and, if not installed and used in accordance with the instructions, may cause harmful interference to radio communications. However, there is no guarantee that interference will not occur in a particular installation. If this equipment does cause harmful interference to radio or television reception, which can be determined by turning the equipment off and on, the user is encouraged to try to correct the interference by one or more of the following measures:

- Reorient or relocate the receiving antenna.
- Increase the separation between the equipment and receiver.
- Connect the equipment into an outlet on a circuit different from that to which the receiver is connected.
- Consult the dealer or an experienced radio/TV technician for help.

#### **CE Requirements:**

\*(Simple EU declaration of conformity) Shenzhen Ysair Technology Co., Ltd. declares that the radio equipment type is in compliance with the essential requirements and other relevant provisions of RED Directive 2014/53/EU and the ROHS Directive 2011/65/EU and the WEEE Directive 2012/19/EU; the full text of the EU declaration of conformity is available at the following internet address: [www.retevis.com](http://www.retevis.com).

#### **\*Restriction Information**

This product can be used in EU countries and regions, including: Belgium (BE), Bulgaria (BG), Czech Republic (CZ), Denmark (DK), Germany (DE), Estonia (EE), Ireland (IE), Greece (EL), Spain (ES), France (FR), Croatia (HR), Italy (IT), Cyprus (CY), Latvia (LV), Lithuania (LT), Luxembourg (LU), Hungary (HU), Malta (MT), Netherlands (NL), Austria (AT), Poland (PL), Portugal (PT), Romania (RO), Slovenia (SI), Slovakia (SK), Finland (FI), Sweden (SE) and United Kingdom (UK).

For the warning information of the frequency restriction, please refer to the package.

#### **\*Disposal**

The crossed-out wheeled-bin symbol on your product, literature, or packaging reminds you that in the European Union, all electrical and electronic products, batteries, and accumulators (rechargeable batteries) must be taken to designated collection locations at the end of their working life. Do not dispose of these products as unsorted municipal waste. Dispose of them according to the laws in your area.



#### **IC Requirements:**

Licence-exempt radio apparatus

This device contains licence-exempt transmitter(s)/receiver(s) that comply with Innovation, Science and Economic Development Canada's licence-exempt RSS(s). Operation is subject to the following two conditions:

- (1) This device may not cause interference.
- (2) This device must accept any interference, including interference that may cause undesired operation of the device.

Le présent appareil est conforme aux CNR d'Industrie Canada applicables aux appareils radio exempts de licence. L'exploitation est autorisée aux deux conditions suivantes :

- (1) l'appareil ne doit pas produire de brouillage;
- (2) l'utilisateur de l'appareil doit accepter tout brouillage radioélectrique subi, même si le brouillage est susceptible d'en compromettre le fonctionnement.

#### **RF Exposure Compliance and Control Guidelines and Operating Instructions**

•Occupational/Controlled Radio, this radio is designed for and classified as "Occupational/Controlled Use Only", meaning it must be used only during the course of employment by individuals aware of the hazards, and the ways to minimize such hazards; NOT intended for use in a General population/uncontrolled environment.

•General population/uncontrolled Radio, this radio is designed for and classified as "General population/uncontrolled Use".

To control your exposure and ensure compliance with the occupational/controlled environment exposure limits, always adhere to the following procedures. When operating in front of the face, worn on the body, always place the radio in a Retevis approved clip, holder, holster, case, or body harness for this product. Using approved body-worn accessories is important because the use of Non-Retevis approved accessories may result in exposure levels, which exceed the IEEE/ICNIRP RF exposure limits.

Transmit no more than the rated duty factor of 50% of the time. To Transmit (Talk), push the Push to Talk (PTT) button. To receive calls (listen), release the PTT button. Transmitting necessary information or less, is important because the radio generates measurable RF energy exposure only when transmitting in terms of measuring for standards compliance.

•DO NOT operate the radio without a proper antenna attached, as this may damage the radio and may also cause you to exceed RF exposure limits. A proper antenna is the antenna supplied with this radio by the manufacturer or an antenna specifically authorized by the manufacturer for use with this radio, and the antenna gain shall not exceed the specified gain by the manufacturer declared.

•DO NOT transmit for more than 50% of total radio use time, more than 50% of the time can cause RF exposure compliance requirements to be exceeded.

•During transmissions, your radio generates RF energy that can possibly cause interference with other devices or systems. To avoid such interference, turn off the radio in areas where signs are posted to do so.

•DO NOT operate the transmitter in areas that are sensitive to electromagnetic radiation such as hospitals, aircraft, and blasting sites.

•Portable Device, this transmitter may operate with the antenna(s) documented in this filing in Push-to-Talk and body-worn configurations. RF exposure compliance is limited to the specific belt-clip and accessory configurations as documented in this filing and the separation distance between head and the device or its antenna shall be at least 2.5 cm.

•Mobile Device, during operation, the separation distance between user and the antenna subjects to actual regulations, this separation distance will ensure that there is sufficient distance from a properly installed externally-mounted antenna to satisfy the RF exposure requirements. Transmit only when people outside the vehicle are at least the recommended minimum lateral distance away from a properly installed according to installation instructions, externally mounted antenna.

#### Hand-held Mode(if applicable)

• Hold the radio in a vertical position with the microphone (and other parts of the radio including the antenna) at least 2.5 cm (one inch) away from the nose or lips. The antenna should be kept away from the eyes. Keeping the radio at a proper distance is important as RF exposure decreases with increasing distance from the antenna.



#### Phone Mode(if applicable)

•When placing or receiving a phone call, hold your radio product as you would a wireless telephone. Speak directly into the microphone. Do not use the equipment when you are driving

#### Electromagnetic Interference/Compatibility

NOTE: Nearly every electronic device is susceptible to electromagnetic interference (EMI) if inadequately shielded, designed, or otherwise configured for electromagnetic compatibility.

#### Avoid Choking Hazard



Small Parts. Not for children under 3 years.

#### Turn off your radio power in the following conditions:



•Turn off your radio before removing (installing) a battery or accessory or when charging battery.  
•Turn off your radio when you are in a potentially hazardous environments: Near electrical blasting caps, in a blasting area, in explosive atmospheres (inflammable gas, dust particles, metallic powders, grain powders, etc.).

•Turn off your radio while taking on fuel or while parked at gasoline service stations.  
To avoid electromagnetic interference and/or compatibility conflicts

- Turn off your radio in any facility where posted notices instruct you to do so, hospitals or health care facilities (Pacemakers, Hearing Aids and Other Medical Devices) may be using equipment that is sensitive to external RF energy.
- Turn off your radio when on board an aircraft. Any use of a radio must be in accordance with applicable regulations per airline crew instructions.

**Protect your hearing:**



- Use the lowest volume necessary to do your job.
- Turn up the volume only if you are in noisy surroundings.
- Turn down the volume before adding headset or earpiece.
- Limit the amount of time you use headsets or earpieces at high volume.
- When using the radio without a headset or earpiece, do not place the radio's speaker directly against your ear
- Use careful with the earphone maybe possible excessive sound pressure from earphones and headphones can cause hearing loss

Note: Exposure to loud noises from any source for extended periods of time may temporarily or permanently affect your hearing. The louder the radio's volume, the less time is required before your hearing could be affected. Hearing damage from loud noise is sometimes undetectable at first and can have a cumulative effect.



**Avoid Burns**



**Antennas**

- Do not use any portable radio that has a damaged antenna. If a damaged antenna comes into contact with the skin when the radio is in use, a minor burn can result.

**Batteries (If appropriate)**

- When the conductive material such as jewelry, keys or chains touch exposed terminals of the batteries, may complete an electrical circuit (short circuit the battery) and become hot to cause bodily injury such as burns. Exercise care in handling any battery, particularly when placing it inside a pocket, purse or other container with metal objects
- **BATTERY WARNING: KEEP OUT OF REACH OF CHILDREN**
- Store spare batteries securely
- If the battery compartment (if applicable) does not close securely, stop using the product and keep it away from children
- If you think batteries might have been swallowed or placed inside any part of the body, seek immediate medical attention
- Dispose of used batteries immediately and safely
- Long transmission
- When the transceiver is used for long transmissions, the radiator and chassis will become hot.

**Safety Operation**



**Forbid**

- Do not use charger outdoors or in moist environments, use only in dry locations/conditions.
- Do not disassemble the charger, that may result in risk of electrical shock or fire.
- Do not operate the charger if it has been broken or damaged in any way.
- Do not place a portable radio in the area over an air bag or in the air bag deployment area. The radio may be propelled with great force and cause serious injury to occupants of the vehicle when the air bag inflates.

**To reduce risk**

- Pull by the plug rather than the cord when disconnecting the charger.
- Unplug the charger from the AC outlet before attempting any maintenance or cleaning.
- Contact Retevis for assistance regarding repairs and service.
- The adapter shall be installed near the equipment and shall be easily accessible

**Approved Accessories**



- This radio meets the RF exposure guidelines when used with the Retevis accessories supplied or designated for the product. Use of other accessories may not ensure compliance with the RF exposure guidelines and may violate regulations.

• For a list of Retevis-approved accessories for your radio model, visit the following website:  
<http://www.Retevis.com>

Out along this line

### Guarantee

Model Number: \_\_\_\_\_  
Serial Number: \_\_\_\_\_  
Purchasing Date: \_\_\_\_\_  
Dealer: \_\_\_\_\_ Telephone: \_\_\_\_\_  
User's Name: \_\_\_\_\_ Telephone: \_\_\_\_\_  
Country: \_\_\_\_\_ Address: \_\_\_\_\_  
Post Code: \_\_\_\_\_ Email: \_\_\_\_\_

#### Remarks:

- 1.This guarantee card should be kept by the user, no replacement if lost.
- 2.Most new products carry a two-year manufacturer's warranty from the date of purchase. Further details, pls read <http://www.retevis.com/after-sale/>
- 3.The user can get warranty and after-sales service as below:
  - Contact the seller where you buy.
  - Products Repaired by Our Local Repair Center
- 4.For warranty service, you will need to provide a receipt proof of purchase from the actual seller for verification

#### Exclusions from Warranty Coverage:

- 1.To any product damaged by accident.
- 2.In the event of misuse or abuse of the product or as a result of unauthorized alterations or repairs.
- 3.If the serial number has been altered, defaced, or removed.



**Shenzhen Ysair Technology Co.,Ltd.**  
6/F, building 6, Yunli intelligent park, No. 3, Changfa Middle Road,  
Yangmei community, Bantian street, Longgang District,  
Shenzhen, Guangdong, China  
Web: [www.retevis.com](http://www.retevis.com)  
E-mail: [kam@retevis.com](mailto:kam@retevis.com)  
Facebook: [facebook.com/retevis](https://facebook.com/retevis)



MADE IN CHINA