



TEST REPORT

Report No.....: **CHTEW22120002** Report Verification: 

Project No.....: **SHT2209079801EW**

FCC ID.....: **2A3OORB48**

Applicant's name.....: **Shenzhen Ysair Technology Co., LTD**

Address.....: 6/F, building 6, Yunli intelligent park, No. 3, Changfa Middle Road, Yangmei community, Bantian street, Longgang District, Shenzhen, Guangdong, China

Test item description: **Two Way Radio**

Trade Mark: RETEVIS

Model/Type reference.....: RB48

Listed Model(s): -

Standard: **FCC CFR Title 47 Part 15 Subpart B**

Date of receipt of test sample.....: Nov.18, 2022

Date of testing.....: Nov.18, 2022- Nov.30, 2022

Date of issue.....: Dec.01, 2022

Result.....: **PASS**

Compiled by
 (Position+Printed name+Signature): File administrator Fanghui Zhu 

Supervised by
 (Position+Printed name+Signature): Project Engineer Xiaodong Zhao 

Approved by
 (position+printed name+signature)...: RF Manager Hans Hu 

Testing Laboratory Name: **Shenzhen Huatongwei International Inspection Co., Ltd.**

Address.....: 1/F, Bldg 3, Hongfa Hi-tech Industrial Park, Genyu Road, Tianliao, Gongming, Shenzhen, China

Shenzhen Huatongwei International Inspection Co., Ltd. All rights reserved.

This publication may be reproduced in whole or in part for non-commercial purposes as long as the Shenzhen Huatongwei International Inspection Co., Ltd. is acknowledged as copyright owner and source of the material. Shenzhen Huatongwei International Inspection Co., Ltd. takes no responsibility for and will not assume liability for damages resulting from the reader's interpretation of the reproduced material due to its placement and context.

The test report merely corresponds to the test sample.

Contents

1.	<u>TEST STANDARDS AND REPORT VERSION</u>	<u>3</u>
1.1.	Test Standards	3
1.2.	Report version	3
2.	<u>TEST DESCRIPTION</u>	<u>4</u>
3.	<u>SUMMARY.....</u>	<u>5</u>
3.1.	Client Information	5
3.2.	Product Description	5
3.3.	Radio Specification Description	5
3.4.	Testing Laboratory Information	6
4.	<u>TEST CONFIGURATION.....</u>	<u>7</u>
4.1.	EUT operation mode	7
4.2.	Support unit used in test configuration	7
4.3.	Environmental conditions	7
4.4.	Statement of the measurement uncertainty	7
4.5.	Equipments Used during the Test	8
5.	<u>TEST CONDITIONS AND RESULTS</u>	<u>9</u>
5.1.	Conducted Emissions	9
5.2.	Radiated Emissions	11
6.	<u>TEST SETUP PHOTOS OF THE EUT</u>	<u>15</u>
7.	<u>EXTERNAL AND INTERNAL PHOTOS OF THE EUT</u>	<u>16</u>

1. TEST STANDARDS AND REPORT VERSION

1.1. Test Standards

The tests were performed according to following standards:

[FCC CFR Title 47 Part 15 Subpart B](#) - Unintentional Radiators

[ANSI C63.4: 2014](#) – American National Standard for Methods of Measurement of Radio-Noise Emissions from Low-Voltage Electrical and Electronic Equipment in the Range of 9 kHz to 40GHz

1.2. Report version

Revision No.	Date of issue	Description
N/A	2022-12-01	Original

2. TEST DESCRIPTION

Test Item	Section in CFR 47	Result
Conducted Emissions	15.107(a)	Pass
Radiated Emissions	15.109(a)	Pass

Note: The measurement uncertainty is not included in the test result.

3. SUMMARY

3.1. Client Information

Applicant:	Shenzhen Ysair Technology Co., LTD
Address:	6/F, building 6, Yunli intelligent park, No. 3, Changfa Middle Road, Yangmei community, Bantian street, Longgang District, Shenzhen,Guangdong,China
Manufacturer:	Shenzhen Ysair Technology Co., LTD
Address:	6/F, building 6, Yunli intelligent park, No. 3, Changfa Middle Road, Yangmei community, Bantian street, Longgang District, Shenzhen,Guangdong,China

3.2. Product Description

Main unit	
Name of EUT:	Two Way Radio
Trade Mark:	RETEVIS
Model/Type reference:	RB48
Listed Model(s)	-
Power supply:	DC 3.7V from battery
Hardware version:	V1.02
Software version:	V1.02
Ancillary unit	
Battery information:	Model: BL648 Voltage: 3.7V Capacity: 2000mAh(7.4Wh)
Charger information:	Model: DC648 Input: 5V/1A Output: 5V/480mA*2

3.3. Radio Specification Description

FRS Frequency Range:	CH01~CH07: 462.5625MHz~ 462.7125MHz CH08~CH14: 467.5625MHz~ 467.7125MHz CH15~CH22: 462.5500MHz~ 462.7250MHz																												
NOAA Weather channel and frequency:	<table border="1"> <thead> <tr> <th>Channel</th> <th>Frequency</th> <th>Channel</th> <th>Frequency</th> </tr> </thead> <tbody> <tr> <td>WX1</td> <td>162.550MHz</td> <td>WX7</td> <td>162.525MHz</td> </tr> <tr> <td>WX2</td> <td>162.400MHz</td> <td>WX8</td> <td>161.650MHz</td> </tr> <tr> <td>WX3</td> <td>162.475MHz</td> <td>WX9</td> <td>161.775MHz</td> </tr> <tr> <td>WX4</td> <td>162.425MHz</td> <td>WX10</td> <td>161.750MHz</td> </tr> <tr> <td>WX5</td> <td>162.450MHz</td> <td>WX11</td> <td>162.000MHz</td> </tr> <tr> <td>WX6</td> <td>162.500MHz</td> <td></td> <td></td> </tr> </tbody> </table>	Channel	Frequency	Channel	Frequency	WX1	162.550MHz	WX7	162.525MHz	WX2	162.400MHz	WX8	161.650MHz	WX3	162.475MHz	WX9	161.775MHz	WX4	162.425MHz	WX10	161.750MHz	WX5	162.450MHz	WX11	162.000MHz	WX6	162.500MHz		
Channel	Frequency	Channel	Frequency																										
WX1	162.550MHz	WX7	162.525MHz																										
WX2	162.400MHz	WX8	161.650MHz																										
WX3	162.475MHz	WX9	161.775MHz																										
WX4	162.425MHz	WX10	161.750MHz																										
WX5	162.450MHz	WX11	162.000MHz																										
WX6	162.500MHz																												

3.4. Testing Laboratory Information

Laboratory Name	Shenzhen Huatongwei International Inspection Co., Ltd.	
Laboratory Location	1/F, Bldg 3, Hongfa Hi-tech Industrial Park, Genyu Road, Tianliao, Gongming, Shenzhen, China	
Connect information:	Tel: 86-755-26715499 E-mail: cs@szhtw.com.cn http://www.szhtw.com.cn	
Qualifications	Type	Accreditation Number
	FCC	762235

4. TEST CONFIGURATION

4.1. EUT operation mode

Test mode	Describe
R1	Keep the EUT in weather receiving mode.
R2	Keep the EUT in FRS receiving mode.
O1	Use the Type-C charging cable to charge, but the EUT shut down.
O2	Use the charging base to charge, but the EUT shut down

Test item	Pretest mode	Worse case mode
Conducted emissions	O1,O2	O2
Radiated emissions	R1,R2,O1,O2	R1

Only show the test data for worse case mode on the test report.

4.2. Support unit used in test configuration

The EUT has been associated with peripherals and configuration operated in a manner tended to maximize its emission characteristics in a typical application.

The following peripheral devices and interface cables were connected during the measurement:

Whether support unit is used?					
✓ Yes					
Item	Equipment	Trade Name	Model No.	FCC ID/FDD SDoC	Power cord
1	Adapter	HUAWEI	HW-050200C01		
2					

4.3. Environmental conditions

During the measurement the environmental conditions were within the listed ranges:

Temperature:	15~35°C
Relative Humidity:	30~60 %
Air Pressure:	950~1050mba

4.4. Statement of the measurement uncertainty

No.	Test Items	Measurement Uncertainty
1	AC Conducted Emission	3.21dB
2	Radiated Emission	4.54dB for 30MHz-1GHz 5.10dB for above 1GHz

This uncertainty represents an expanded uncertainty expressed at approximately the 95% confidence level using a coverage factor of k=1.96.

4.5. Equipments Used during the Test

● Conducted Emission							
Used	Test Equipment	Manufacturer	Equipment No.	Model No.	Serial No.	Last Cal. Date (YY-MM-DD)	Next Cal. Date (YY-MM-DD)
●	Shielded Room	Albatross projects	HTWE0114	N/A	N/A	2018/09/28	2023/09/27
●	EMI Test Receiver	R&S	HTWE0111	ESCI	101247	2022/08/30	2023/08/29
●	Artificial Mains	SCHWARZBECK	HTWE0113	NNLK 8121	573	2022/08/29	2023/08/28
●	Pulse Limiter	R&S	HTWE0193	ESH3-Z2	101447	2022/08/29	2023/08/28
●	RF Connection Cable	HUBER+SUHNER	HTWE0113-02	ENVIROFLEX_142	EF-NM-BNCM-2M	2022/09/17	2023/09/16
●	Test Software	R&S	N/A	ES-K1	N/A	N/A	N/A

● Radiated Emission-6th test site							
Used	Test Equipment	Manufacturer	Equipment No.	Model No.	Serial No.	Last Cal. Date (YY-MM-DD)	Next Cal. Date (YY-MM-DD)
●	Semi-Anechoic Chamber	Albatross projects	HTWE0127	SAC-3m-02	C11121	2018/09/30	2023/09/29
●	EMI Test Receiver	R&S	HTWE0099	ESCI	100900	2022/08/30	2023/08/29
●	Ultra-Broadband Antenna	SCHWARZBECK	HTWE0119	VULB9163	546	2020/04/28	2023/04/27
●	Pre-Amplifier	SCHWARZBECK	HTWE0295	BBV 9742	N/A	2022/11/04	2023/11/03
●	RF Connection Cable	HUBER+SUHNER	HTWE0062-01	N/A	N/A	2022/02/25	2023/02/24
●	RF Connection Cable	HUBER+SUHNER	HTWE0062-02	SUCOFLEX104	501184/4	2022/02/25	2023/02/24
●	Test Software	R&S	N/A	ES-K1	N/A	N/A	N/A

● Radiated emission-7th test site							
Used	Test Equipment	Manufacturer	Equipment No.	Model No.	Serial No.	Last Cal. Date (YY-MM-DD)	Next Cal. Date (YY-MM-DD)
●	Semi-Anechoic Chamber	Albatross projects	HTWE0122	SAC-3m-01	C11121	2018/09/27	2023/09/26
●	Spectrum Analyzer	R&S	HTWE0098	FSP40	100597	2022/08/25	2023/08/24
●	Horn Antenna	SCHWARZBECK	HTWE0126	9120D	1011	2020/04/01	2023/03/31
●	Broadband Pre-amplifier	SCHWARZBECK	HTWE0201	BBV 9718	9718-248	2022/02/28	2023/02/27
●	RF Connection Cable	HUBER+SUHNER	HTWE0126-01	RE-7-FH	N/A	2022/03/04	2023/03/03
●	Test Software	Audix	N/A	E3	N/A	N/A	N/A

5. TEST CONDITIONS AND RESULTS

5.1. Conducted Emissions

LIMIT

FCC CFR Title 47 Part 15 Subpart B Section 15.107:

Frequency range (MHz)	Limit (dBuV)	
	Quasi-peak	Average
0.15-0.5	66 to 56*	56 to 46*
0.5-5	56	46
5-30	60	50

* Decreases with the logarithm of the frequency.

TEST CONFIGURATION

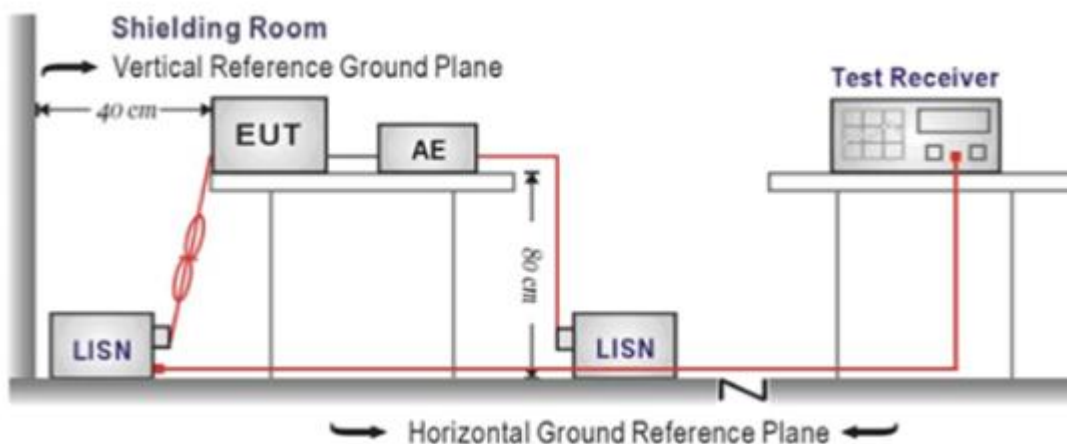

TEST PROCEDURE

1. The EUT was setup according to ANSI C63.4:2014
2. The EUT was placed on a plat form of nominal size, 1 m by 1.5 m, raised 10 cm above the conducting ground plane. The vertical conducting plane was located 40 cm to the rear of the EUT. All other surfaces of EUT were at least 10 cm from any other grounded conducting surface.
3. The EUT and simulators are connected to the main power through a line impedance stabilization network (LISN). The LISN provides a 50ohm / 50uH coupling impedance for the measuring equipment.
4. The peripheral devices are also connected to the main power through a LISN. (Please refer to the block diagram of the test setup and photographs)
5. Each current-carrying conductor of the EUT power cord, except the ground (safety) conductor, was individually connected through a LISN to the input power source.
6. The excess length of the power cord between the EUT and the LISN receptacle were folded back and forth at the center of the lead to form a bundle not exceeding 40 cm in length.
7. Conducted emissions were investigated over the frequency range from 0.15MHz to 30MHz using a receiver bandwidth of 9 kHz.
8. During the above scans, the emissions were maximized by cable manipulation.

TEST MODE:

Please refer to the clause 4.1

TEST RESULTS

Passed Not Applicable

Test Line:

L

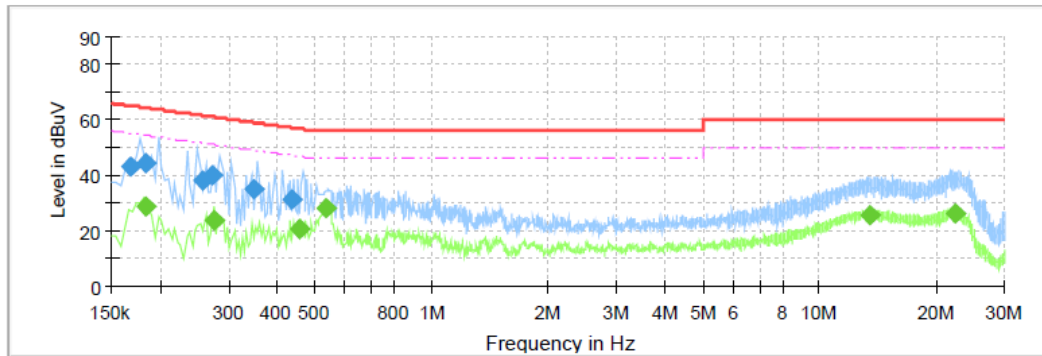

Final Result

Frequency (MHz)	QuasiPeak (dBuV)	CAverage (dBuV)	Limit (dBuV)	Margin (dB)	Line	Corr. (dB)
0.167500	43.01	---	65.08	22.07	L1	10.0
0.183500	44.08	---	64.33	20.24	L1	10.0
0.183500	---	28.55	54.33	25.78	L1	10.0
0.256500	38.17	---	61.54	23.38	L1	10.0
0.271500	40.23	---	61.07	20.84	L1	10.0
0.275500	---	23.62	50.95	27.33	L1	10.0
0.347500	34.71	---	59.02	24.31	L1	10.0
0.436500	31.15	---	57.13	25.97	L1	10.0
0.455500	---	20.93	46.77	25.84	L1	10.0
0.535500	---	28.20	46.00	17.80	L1	10.0
13.455500	---	25.73	50.00	24.27	L1	10.4
22.407500	---	26.01	50.00	23.99	L1	10.5

Test Line:

N

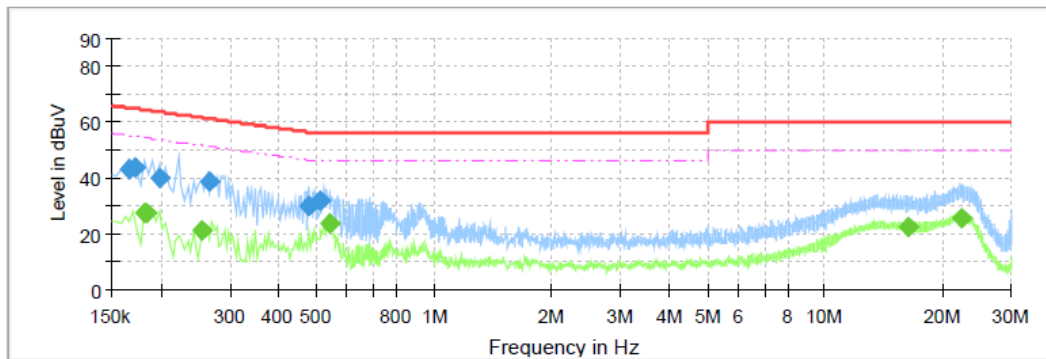

Final Result

Frequency (MHz)	QuasiPeak (dBuV)	CAverage (dBuV)	Limit (dBuV)	Margin (dB)	Line	Corr. (dB)
0.166000	43.41	---	65.16	21.75	N	10.0
0.171500	43.94	---	64.89	20.95	N	10.0
0.182000	---	27.78	54.39	26.61	N	10.0
0.183500	---	27.26	54.33	27.07	N	10.0
0.199500	39.78	---	63.63	23.86	N	10.0
0.255500	---	21.12	51.58	30.45	N	10.0
0.267500	38.63	---	61.20	22.57	N	10.0
0.479500	30.29	---	56.35	26.06	N	10.0
0.511500	31.96	---	56.00	24.04	N	10.0
0.543500	---	23.66	46.00	22.34	N	10.0
16.375500	---	22.58	50.00	27.43	N	10.4
22.279500	---	25.85	50.00	24.15	N	10.6

5.2. Radiated Emissions

LIMIT

FCC CFR Title 47 Part 15 Subpart B Section 15.109

Frequency	Limit (dBuV/m @3m)	Value
30MHz-88MHz	40.00	Quasi-peak
88MHz-216MHz	43.50	Quasi-peak
216MHz-960MHz	46.00	Quasi-peak
960MHz-1GHz	54.00	Quasi-peak
Above 1GHz	54.00	Average
	74.00	Peak

TEST CONFIGURATION

➤ 30MHz ~ 1GHz

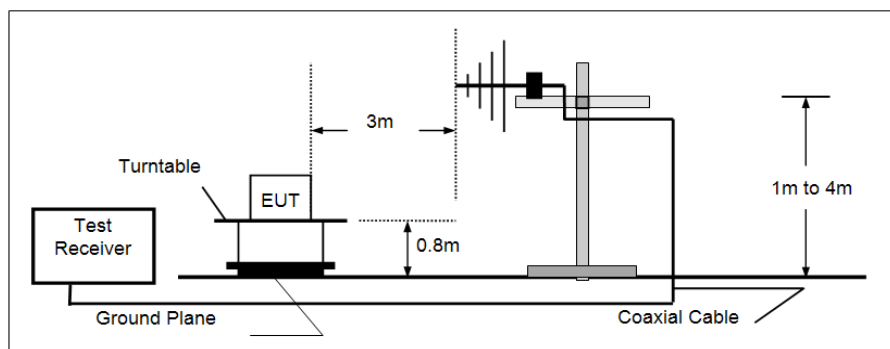

➤ Above 1GHz

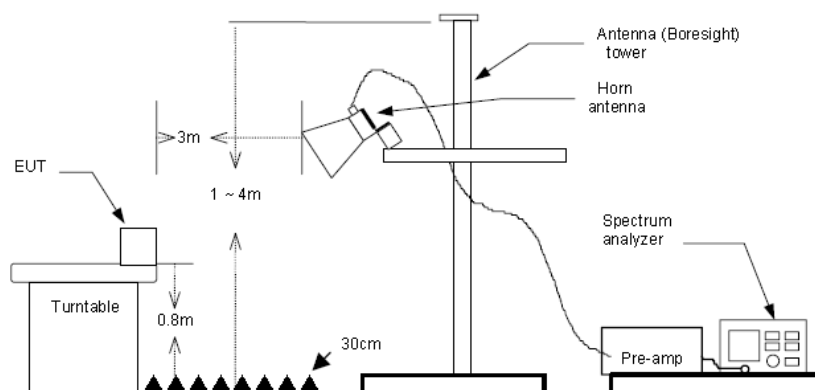

TEST PROCEDURE

1. The EUT was tested according to ANSI C63.4:2014.
2. The EUT is placed on a turn table which is 0.8 meter above ground.
3. The turn table is rotated 360 degrees to determine the position of the maximum emission level.
4. The EUT was positioned such that the distance from antenna to the EUT was 3 meters.
5. The antenna is scanned from 1 meter to 4 meters to find out the maximum emission level. This is repeated for both horizontal and vertical polarization of the antenna.
6. Use the following spectrum analyzer settings
 - (1) Span shall wide enough to fully capture the emission being measured;
 - (2) Below 1GHz,
RBW=120KHz, VBW=300KHz, Sweep=auto, Detector function=peak, Trace=max hold;
If the emission level of the EUT measured by the peak detector is 3 dB lower than the applicable limit, the peak emission level will be reported. Otherwise, the emission measurement will be repeated using the quasi-peak detector and reported.
 - (3) From 1GHz to 5th harmonic, RBW=1MHz, VBW=3MHz

TEST MODE:

Please refer to the clause 4.1

TEST RESULTS

Passed **Not Applicable**

Note: Final Level = Receiver Read level + Antenna Factor + Cable Loss – Preamplifier Factor
The emission levels of frequency above 6GHz are very lower than limit and not show in test report.

Polarization:

Horizontal

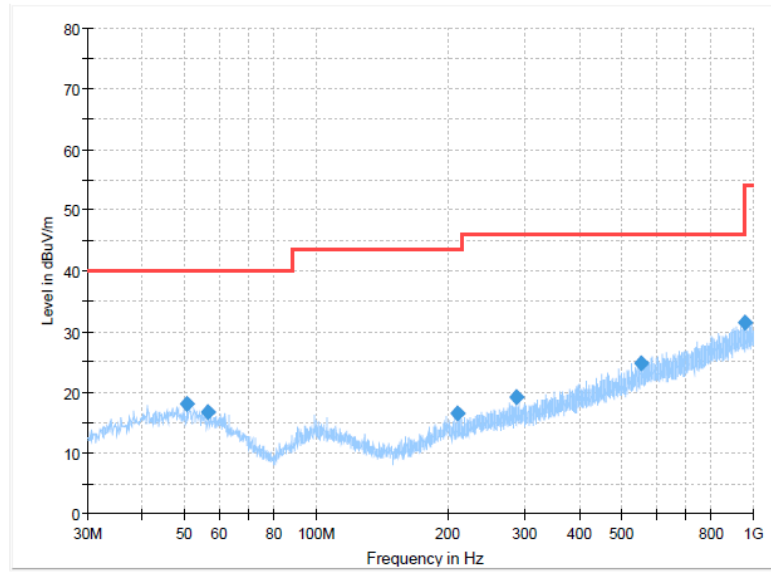

Final Result

Frequency (MHz)	MaxPeak (dBuV/m)	Limit (dBuV/m)	Margin (dB)	Height (cm)	Pol	Azimuth (deg)	Corr. (dB/m)
50.733750	18.08	40.00	21.92	100.0	H	350.0	-9.2
56.553750	16.74	40.00	23.26	300.0	H	10.0	-9.7
210.662500	16.52	43.50	26.98	100.0	H	1.0	-10.3
286.322500	19.25	46.00	26.75	100.0	H	200.0	-8.0
552.951250	24.90	46.00	21.10	300.0	H	328.0	-0.4
955.865000	31.47	46.00	14.53	300.0	H	197.0	7.1

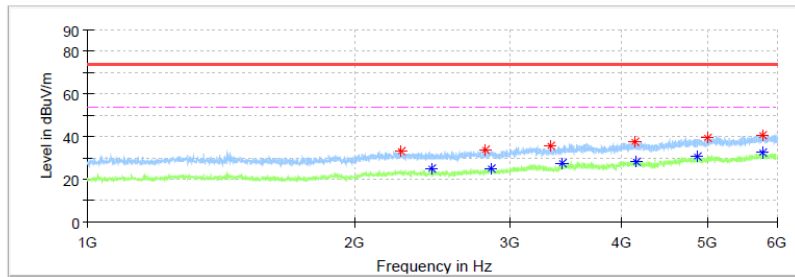

Critical Freqs

Frequency (MHz)	MaxPeak (dBuV/m)	Average (dBuV/m)	Limit (dBuV/m)	Margin (dB)	Height (cm)	Pol	Azimuth (deg)	Corr. (dB/m)
5014.375000	39.26	---	74.00	34.74	160.0	H	0.0	3.0
2256.875000	32.95	---	74.00	41.05	160.0	H	10.0	-6.6
4879.375000	---	30.84	54.00	23.16	160.0	H	10.0	2.5
5770.625000	40.86	---	74.00	33.14	160.0	H	25.0	5.0
4163.125000	---	28.32	54.00	25.68	160.0	H	39.0	-1.1
2811.250000	33.70	---	74.00	40.30	160.0	H	53.0	-5.9
2856.250000	---	24.84	54.00	29.16	160.0	H	81.0	-5.7
2442.500000	---	24.79	54.00	29.21	160.0	H	95.0	-6.8
3331.875000	35.88	---	74.00	38.12	160.0	H	95.0	-4.7
3437.500000	---	27.29	54.00	26.71	160.0	H	95.0	-3.9
5772.500000	---	32.57	54.00	21.43	160.0	H	109.0	5.0
4151.250000	37.29	---	74.00	36.71	160.0	H	193.0	-1.2

Polarization:

Vertical

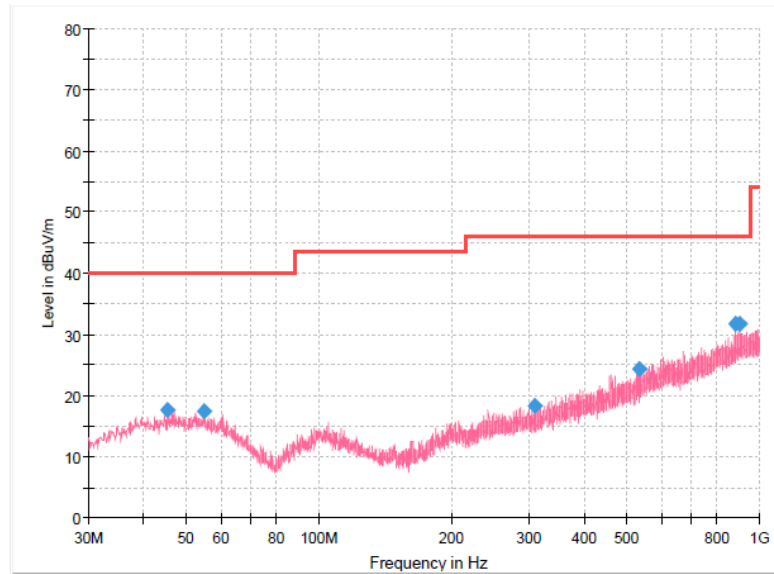

Final Result

Frequency (MHz)	MaxPeak (dBuV/m)	Limit (dBuV/m)	Margin (dB)	Height (cm)	Pol	Azimuth (deg)	Corr. (dB/m)
45.520000	17.55	40.00	22.45	100.0	V	86.0	-9.4
54.856250	17.37	40.00	22.63	100.0	V	116.0	-9.6
309.238750	18.39	46.00	27.61	100.0	V	145.0	-7.2
533.551250	24.31	46.00	21.69	100.0	V	211.0	-1.0
878.992500	31.65	46.00	14.35	100.0	V	0.0	5.8
904.818750	31.70	46.00	14.30	100.0	V	145.0	6.3

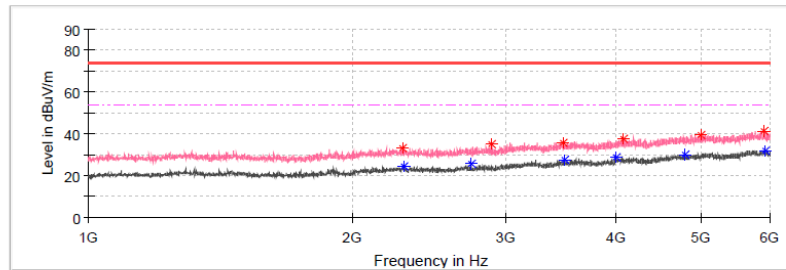

Critical Freqs

Frequency (MHz)	MaxPeak (dBuV/m)	Average (dBuV/m)	Limit (dBuV/m)	Margin (dB)	Height (cm)	Pol	Azimuth (deg)	Corr. (dB/m)
2891.250000	34.77	---	74.00	39.23	160.0	V	23.0	-5.7
5918.750000	41.33	---	74.00	32.67	160.0	V	79.0	5.4
2738.125000	---	25.39	54.00	28.61	160.0	V	107.0	-5.9
3481.250000	35.70	---	74.00	38.30	160.0	V	163.0	-3.6
5005.000000	39.61	---	74.00	34.39	160.0	V	177.0	2.9
4798.125000	---	30.16	54.00	23.84	160.0	V	191.0	2.2
5925.000000	---	32.13	54.00	21.87	160.0	V	233.0	5.5
4013.750000	---	28.94	54.00	25.06	160.0	V	261.0	-1.7
3496.875000	---	27.42	54.00	26.58	160.0	V	275.0	-3.6
2287.500000	33.04	---	74.00	40.96	160.0	V	303.0	-6.7
2296.250000	---	24.22	54.00	29.78	160.0	V	317.0	-6.7
4081.875000	37.30	---	74.00	36.70	160.0	V	345.0	-1.5

6. TEST SETUP PHOTOS OF THE EUT

Conducted Emissions (AC Mains)



Radiated Emissions (30MHz-1GHz)



Radiated Emissions (Above 1GHz)



7. EXTERNAL AND INTERNAL PHOTOS OF THE EUT

Please refer to the test report No.: CHTEW22120001

-----End of Report-----