

# TEST REPORT

**Report No.**.....: **CHTEW2204005101** Report Verification   
**Project No.**.....: **SHT2111066106EW**  
**FCC ID**.....: **2A3OORB28**  
**Applicant's name**.....: **Shenzhen Ysair Technology Co., Ltd.**  
**Address**.....: 6/F, building 6, Yunli intelligent park, No. 3, Changfa Middle Road,  
Yangmei community, Bantian street, Longgang District, Shenzhen,  
China  
**Test item description** .....: **Two way radio**  
**Trade Mark** .....: RETEVIS  
**Model/Type reference**.....: RB28  
**Listed Model(s)** .....: RB28B  
**Standard** .....: **FCC CFR Title 47 Part 15 Subpart B**  
**Date of receipt of test sample**.....: Jan.05, 2022  
**Date of testing**.....: Jan.06, 2022- Mar.04, 2022  
**Date of issue**.....: Apr.08, 2022  
**Result**.....: **PASS**

Compiled by  
(Position - Printed name - Signature): File administrators Fanghui Zhu



Supervised by  
(Position - Printed name - Signature): Project Engineer Cheng Xiao



Approved by  
( position+printed name+signature)..: RF Manager Hans Hu



**Testing Laboratory Name** .....: **Shenzhen Huatongwei International Inspection Co., Ltd.**  
**Address**.....: 1/F, Bldg 3, Hongfa Hi-tech Industrial Park, Genyu Road, Tianliao,  
Gongming, Shenzhen, China

**Shenzhen Huatongwei International Inspection Co., Ltd. All rights reserved.**

This publication may be reproduced in whole or in part for non-commercial purposes as long as the Shenzhen Huatongwei International Inspection Co., Ltd. is acknowledged as copyright owner and source of the material. Shenzhen Huatongwei International Inspection Co., Ltd. takes no responsibility for and will not assume liability for damages resulting from the reader's interpretation of the reproduced material due to its placement and context.

*The test report merely corresponds to the test sample.*

## Contents

<b>1.</b>	<b><u>TEST STANDARDS AND REPORT VERSION .....</u></b>	<b><u>3</u></b>
1.1.	Test Standards	3
1.2.	Report version	3
<b>2.</b>	<b><u>TEST DESCRIPTION .....</u></b>	<b><u>3</u></b>
<b>3.</b>	<b><u>SUMMARY.....</u></b>	<b><u>4</u></b>
3.1.	Client Information	4
3.2.	Product Description	4
3.3.	Radio Specification Description	5
3.4.	Testing Laboratory Information	5
<b>4.</b>	<b><u>TEST CONFIGURATION.....</u></b>	<b><u>6</u></b>
4.1.	EUT operation mode	6
4.2.	Support unit used in test configuration	6
4.3.	Environmental conditions	6
4.4.	Statement of the measurement uncertainty	6
4.5.	Equipments Used during the Test	7
<b>5.</b>	<b><u>TEST CONDITIONS AND RESULTS .....</u></b>	<b><u>8</u></b>
5.1.	Conducted Emissions	8
5.2.	Radiated Emissions	11
<b>6.</b>	<b><u>TEST SETUP PHOTOS OF THE EUT .....</u></b>	<b><u>15</u></b>
<b>7.</b>	<b><u>EXTERNAL AND INTERNAL PHOTOS OF THE EUT .....</u></b>	<b><u>16</u></b>

## 1. TEST STANDARDS AND REPORT VERSION

### 1.1. Test Standards

The tests were performed according to following standards:

[FCC CFR Title 47 Part 15 Subpart B](#) - Unintentional Radiators

[ANSI C63.4: 2014](#) – American National Standard for Methods of Measurement of Radio-Noise Emissions from Low-Voltage Electrical and Electronic Equipment in the Range of 9 kHz to 40GHz

### 1.2. Report version

Revision No.	Date of issue	Description
N/A	2022-04-08	Change Applicant's name and Address, update product name and test model ,update trademark based on the report CHTEW22030036

## 2. TEST DESCRIPTION

Test Item	Section in CFR 47	Result	Test Engineer
Conducted Emissions	15.107(a)	Pass	Quanhai Deng
Radiated Emissions	15.109(a)	Pass	Hongbin Zhong

Note: The measurement uncertainty is not included in the test result.

### 3. SUMMARY

#### 3.1. Client Information

Applicant:	Shenzhen Ysair Technology Co., Ltd.
Address:	6/F, building 6, Yunli intelligent park, No. 3, Changfa Middle Road, Yangmei community, Bantian street, Longgang District, Shenzhen, China

#### 3.2. Product Description

Main unit	
Name of EUT:	Two way radio
Trade Mark:	RETEVIS
Model/Type reference:	RB28
Listed Model(s)	RB28B
Power supply:	DC 3.7V
Hardware version:	V1.1
Software version:	V1.1
Ancillary unit	
Battery information:	Model No.: BL628 Voltage: 3.7V Capacity: 1500mAh(5.55Wh) Rechargeable Li-ion battery pack
Adapter information: (sale without adapter)	Model:SICO More 3 Input: 100-240,50/60Hz 0.3A Output:5.0V,0.7A Manufacturer:Shenzhen East Sun Electronic Co., Ltd

### 3.3. Radio Specification Description

Support Frequency Range:	CH01~CH07: 462.5625MHz~ 462.7125MHz CH08~CH14: 467.5625MHz~ 467.7125MHz CH15~CH22: 462.5500MHz~ 462.7250MHz
Modulation Type:	FM
Emission Designator: *1	11K0F3E
Antenna Type:	integral antenna
Antenna Gain:	1.4dBi

### 3.4. Testing Laboratory Information

Laboratory Name	Shenzhen Huatongwei International Inspection Co., Ltd.	
Laboratory Location	1/F, Bldg 3, Hongfa Hi-tech Industrial Park, Genyu Road, Tianliao, Gongming, Shenzhen, China	
Connect information:	Tel: 86-755-26715499 E-mail: <a href="mailto:cs@szhtw.com.cn">cs@szhtw.com.cn</a> <a href="http://www.szhtw.com.cn">http://www.szhtw.com.cn</a>	
Qualifications	Type	Accreditation Number
	FCC	762235

## 4. TEST CONFIGURATION

### 4.1. EUT operation mode

Test mode	Describe
Charging mode	Keep the EUT in charging mode, but the EUT shut down.
Receive mode	Keep the EUT in receiving mode, but don't charging.

Receive frequency: 462.6375MHz.

Test item	Pretest mode	Worse case mode
Conducted emissions	Charging mode, receive mode	Charging mode
Radiated emissions	Charging mode, receive mode	Charging mode

Only show the test data for worse case mode on the test report.

### 4.2. Support unit used in test configuration

The EUT has been associated with peripherals and configuration operated in a manner tended to maximize its emission characteristics in a typical application.

The following peripheral devices and interface cables were connected during the measurement:

Whether support unit is used?					
✓ No					
Item	Equipment	Trade Name	Model No.	FCC ID	Power cord
1					
2					

### 4.3. Environmental conditions

During the measurement the environmental conditions were within the listed ranges:

Temperature:	15~35°C
Relative Humidity:	30~60 %
Air Pressure:	950~1050mba

### 4.4. Statement of the measurement uncertainty

Test	Frequency range	Measurement uncertainty
Radiated Emission	30~1000MHz	4.90 dB
Radiated Emission	1~18GHz	4.96 dB
Conducted Disturbance	0.15~30MHz	3.02 dB

This uncertainty represents an expanded uncertainty expressed at approximately the 95% confidence level using a coverage factor of k=1.96.

#### 4.5. Equipments Used during the Test

● Conducted Emission							
Used	Test Equipment	Manufacturer	Equipment No.	Model No.	Serial No.	Last Cal. Date (YY-MM-DD)	Next Cal. Date (YY-MM-DD)
●	Shielded Room	Albatross projects	HTWE0114	N/A	N/A	2018/09/28	2023/09/27
●	EMI Test Receiver	R&S	HTWE0111	ESCI	101247	2021/09/14	2022/09/13
●	Artificial Mains	SCHWARZBECK	HTWE0113	NNLK 8121	573	2021/09/17	2022/09/16
●	Pulse Limiter	R&S	HTWE0193	ESH3-Z2	101447	2021/09/16	2022/09/15
●	RF Connection Cable	HUBER+SUHNER	HTWE0113-02	ENVIROFLEX_142	EF-NM-BNCM-2M	2021/09/17	2022/09/16
●	Test Software	R&S	N/A	ES-K1	N/A	N/A	N/A

● Radiated Emission-6th test site							
Used	Test Equipment	Manufacturer	Equipment No.	Model No.	Serial No.	Last Cal. Date (YY-MM-DD)	Next Cal. Date (YY-MM-DD)
●	Semi-Anechoic Chamber	Albatross projects	HTWE0127	SAC-3m-02	C11121	2018/09/30	2022/09/29
●	EMI Test Receiver	R&S	HTWE0099	ESCI	100900	2021/09/14	2022/09/13
●	Ultra-Broadband Antenna	SCHWARZBECK	HTWE0119	VULB9163	546	2020/04/28	2023/04/27
●	Pre-Amplifier	SCHWARZBECK	HTWE0295	BBV 9742	N/A	2021/11/05	2022/11/04
●	RF Connection Cable	HUBER+SUHNER	HTWE0062-01	N/A	N/A	2022/02/25	2023/02/24
●	RF Connection Cable	HUBER+SUHNER	HTWE0062-02	SUCOFLEX104	501184/4	2022/02/25	2023/02/24
●	Test Software	R&S	N/A	ES-K1	N/A	N/A	N/A

● Radiated emission-7th test site							
Used	Test Equipment	Manufacturer	Equipment No.	Model No.	Serial No.	Last Cal. Date (YY-MM-DD)	Next Cal. Date (YY-MM-DD)
●	Semi-Anechoic Chamber	Albatross projects	HTWE0122	SAC-3m-01	C11121	2018/09/27	2022/09/26
●	Spectrum Analyzer	R&S	HTWE0098	FSP40	100597	2021/09/13	2022/09/12
●	Horn Antenna	SCHWARZBECK	HTWE0126	9120D	1011	2020/04/01	2023/03/31
●	Broadband Pre-amplifier	SCHWARZBECK	HTWE0201	BBV 9718	9718-248	2021/03/05	2022/03/04
●	RF Connection Cable	HUBER+SUHNER	HTWE0126-01	RE-7-FH	N/A	2021/03/05	2022/03/04
●	Test Software	Audix	N/A	E3	N/A	N/A	N/A

## 5. TEST CONDITIONS AND RESULTS

### 5.1. Conducted Emissions

#### LIMIT

FCC CFR Title 47 Part 15 Subpart B Section 15.107:

Frequency range (MHz)	Limit (dBuV)	
	Quasi-peak	Average
0.15-0.5	66 to 56*	56 to 46*
0.5-5	56	46
5-30	60	50

\* Decreases with the logarithm of the frequency.

#### TEST CONFIGURATION

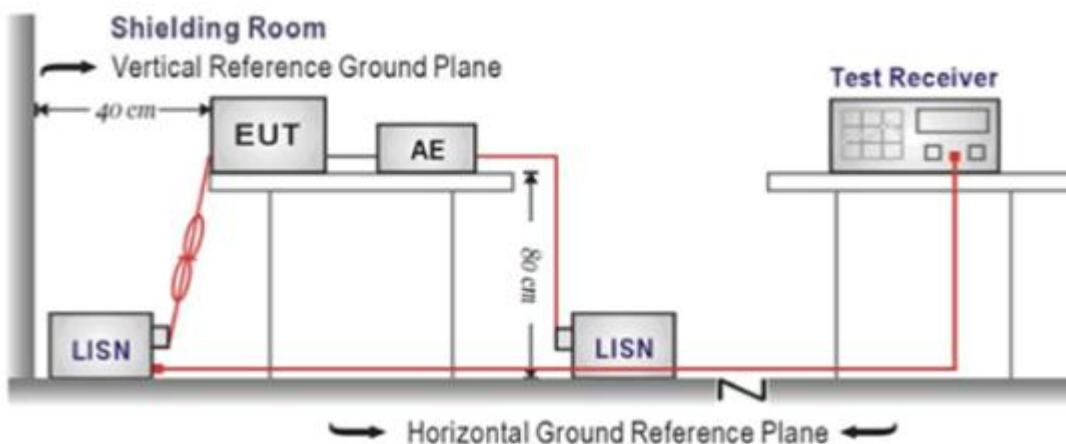

#### TEST PROCEDURE

1. The EUT was setup according to ANSI C63.4:2014
2. The EUT was placed on a plat form of nominal size, 1 m by 1.5 m, raised 10 cm above the conducting ground plane. The vertical conducting plane was located 40 cm to the rear of the EUT. All other surfaces of EUT were at least 10 cm from any other grounded conducting surface.
3. The EUT and simulators are connected to the main power through a line impedance stabilization network (LISN). The LISN provides a 50ohm / 50uH coupling impedance for the measuring equipment.
4. The peripheral devices are also connected to the main power through a LISN. (Please refer to the block diagram of the test setup and photographs)
5. Each current-carrying conductor of the EUT power cord, except the ground (safety) conductor, was individually connected through a LISN to the input power source.
6. The excess length of the power cord between the EUT and the LISN receptacle were folded back and forth at the center of the lead to form a bundle not exceeding 40 cm in length.
7. Conducted emissions were investigated over the frequency range from 0.15MHz to 30MHz using a receiver bandwidth of 9 kHz.
8. During the above scans, the emissions were maximized by cable manipulation.

#### TEST MODE:

Please refer to the clause 4.1

#### TEST RESULTS

Passed       Not Applicable



Test Line:

L

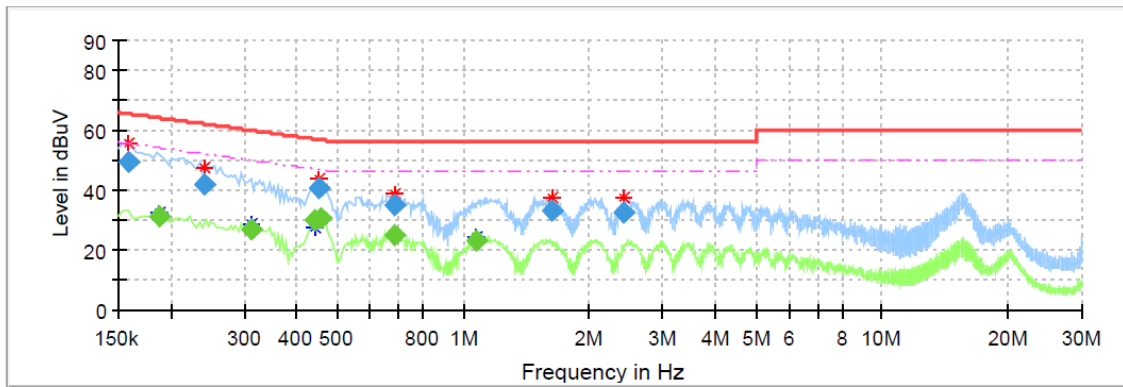

Frequency (MHz)	QuasiPeak (dBuV)	CAverage (dBuV)	Limit (dBuV)	Margin (dB)	Line	Corr. (dB)
0.158000	49.42	---	65.57	16.15	L1	10.1
0.187500	---	31.36	54.15	22.79	L1	10.1
0.239500	42.05	---	62.11	20.06	L1	10.1
0.311500	---	26.83	49.93	23.10	L1	10.1
0.443500	---	29.76	47.00	17.24	L1	10.1
0.451500	40.77	---	56.85	16.08	L1	10.1
0.455500	---	30.42	46.77	16.35	L1	10.1
0.683500	34.76	---	56.00	21.24	L1	10.2
0.683500	---	24.78	46.00	21.22	L1	10.2
1.079500	---	23.34	46.00	22.66	L1	10.1
1.632500	32.94	---	56.00	23.06	L1	10.1
2.427500	32.41	---	56.00	23.59	L1	10.2

Test Line:

N

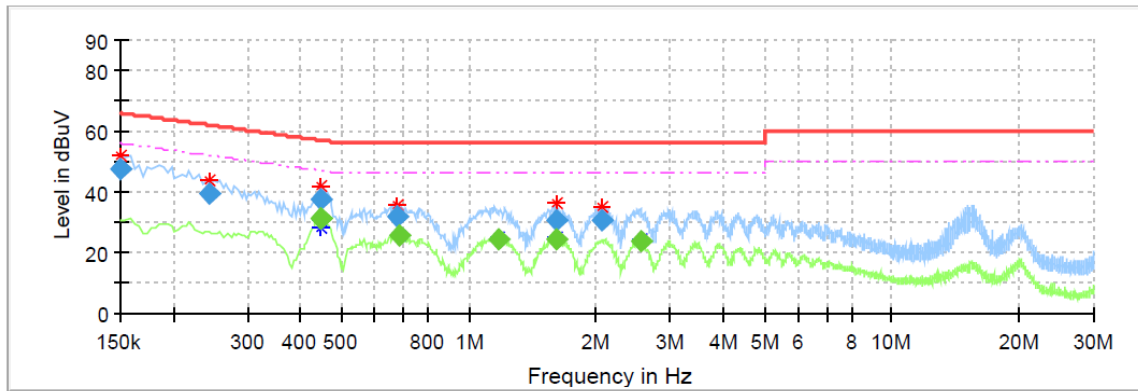

Frequency (MHz)	QuasiPeak (dBuV)	CAverage (dBuV)	Limit (dBuV)	Margin (dB)	Line	Corr. (dB)
0.150000	47.30	---	66.00	18.70	N	10.1
0.243500	39.59	---	61.98	22.39	N	10.1
0.447500	---	31.08	46.92	15.84	N	10.1
0.447500	37.74	---	56.92	19.18	N	10.1
0.448500	---	31.06	46.90	15.84	N	10.1
0.675500	31.93	---	56.00	24.07	N	10.2
0.683500	---	25.35	46.00	20.65	N	10.2
1.171500	---	24.64	46.00	21.36	N	10.1
1.603500	---	24.50	46.00	21.50	N	10.1
1.607500	30.81	---	56.00	25.19	N	10.1
2.067500	30.60	---	56.00	25.40	N	10.1
2.543500	---	23.65	46.00	22.35	N	10.1

## 5.2. Radiated Emissions

### LIMIT

#### FCC CFR Title 47 Part 15 Subpart B Section 15.109

Frequency	Limit (dBuV/m @3m)	Value
30MHz-88MHz	40.00	Quasi-peak
88MHz-216MHz	43.50	Quasi-peak
216MHz-960MHz	46.00	Quasi-peak
960MHz-1GHz	54.00	Quasi-peak
Above 1GHz	54.00	Average
	74.00	Peak

### TEST CONFIGURATION

#### ➤ 30MHz ~ 1GHz

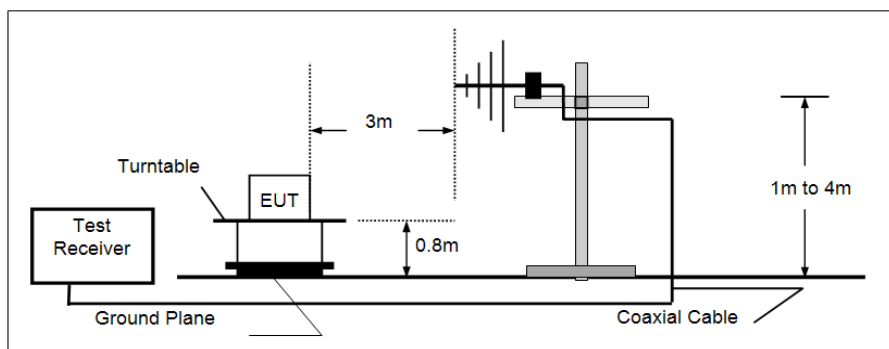

#### ➤ Above 1GHz

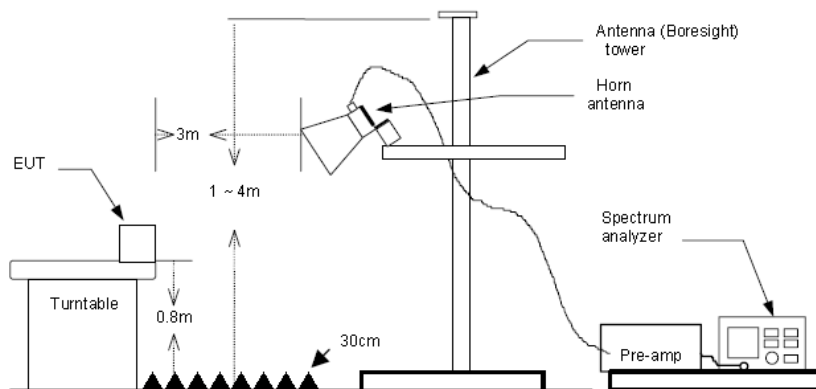

### TEST PROCEDURE

- The EUT was tested according to ANSI C63.4:2014.
- The EUT is placed on a turn table which is 0.8 meter above ground.
- The turn table is rotated 360 degrees to determine the position of the maximum emission level.
- The EUT was positioned such that the distance from antenna to the EUT was 3 meters.
- The antenna is scanned from 1 meter to 4 meters to find out the maximum emission level. This is repeated for both horizontal and vertical polarization of the antenna.
- Use the following spectrum analyzer settings
  - Span shall wide enough to fully capture the emission being measured;
  - Below 1GHz,
    - RBW=120KHz, VBW=300KHz, Sweep=auto, Detector function=peak, Trace=max hold;
    - If the emission level of the EUT measured by the peak detector is 3 dB lower than the applicable limit, the peak emission level will be reported. Otherwise, the emission measurement will be repeated using the quasi-peak detector and reported.
  - From 1GHz to 5th harmonic, RBW=1MHz, VBW=3MHz

**TEST MODE:**

Please refer to the clause 4.1

**TEST RESULTS**

**Passed**       **Not Applicable**

Note: Final Level = Receiver Read level + Antenna Factor + Cable Loss – Preamplifier Factor  
The emission levels of frequency above 6GHz are very lower than limit and not show in test report.

Polarization:

Horizontal

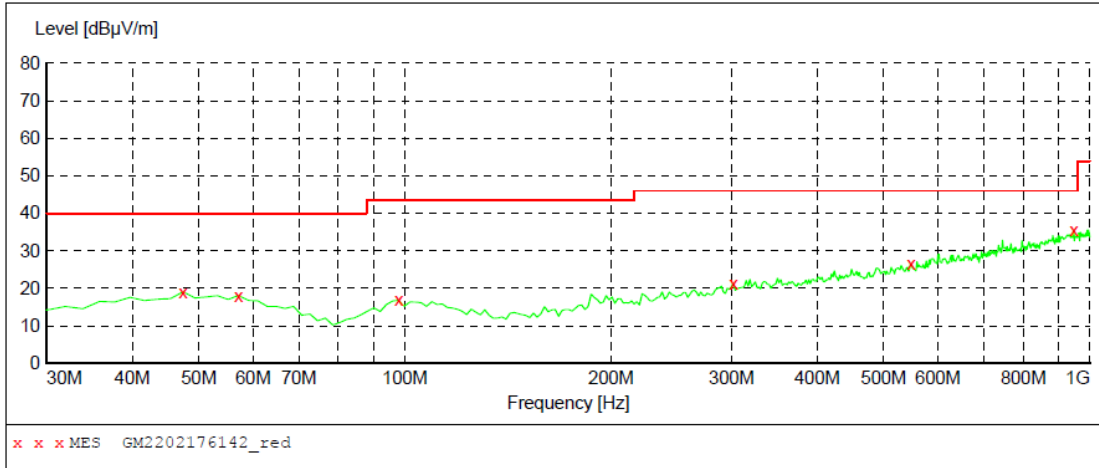

**MEASUREMENT RESULT: "GM2202176142\_red"**

2/18/2022 1:21AM

Frequency MHz	Level dBµV/m	Transd dB	Limit dBµV/m	Margin dB	Det.	Height cm	Azimuth deg	Polarization
47.460000	19.10	-8.8	40.0	20.9	QP	100.0	249.00	HORIZONTAL
57.160000	18.10	-9.5	40.0	21.9	QP	100.0	9.00	HORIZONTAL
97.900000	16.80	-11.1	43.5	26.7	QP	100.0	238.00	HORIZONTAL
301.600000	21.40	-7.3	46.0	24.6	QP	100.0	70.00	HORIZONTAL
547.980000	26.50	-0.8	46.0	19.5	QP	100.0	321.00	HORIZONTAL
947.620000	35.50	7.4	46.0	10.5	QP	100.0	238.00	HORIZONTAL

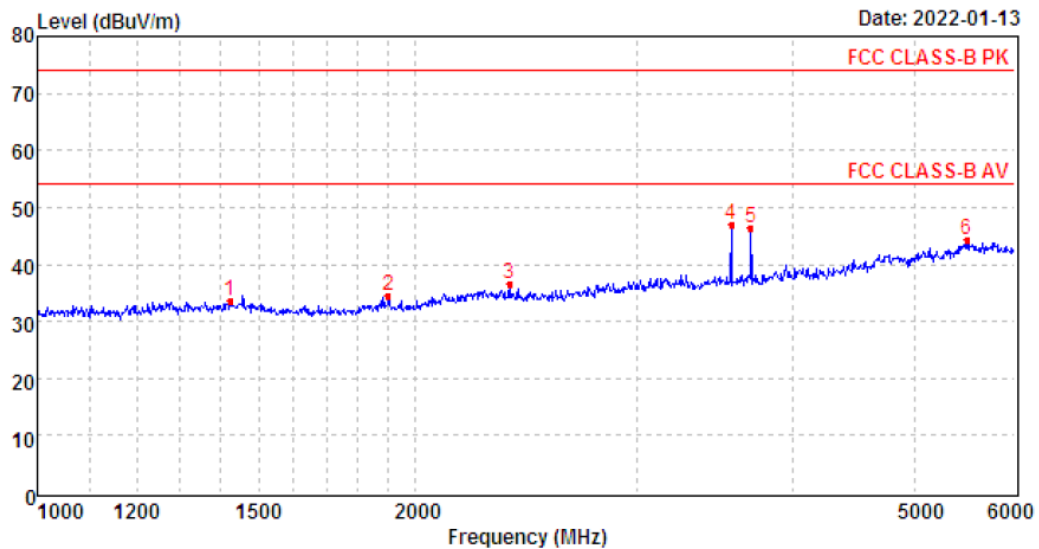

Mark	Frequency MHz	Reading dBuV/m	Antenna dB	Cable dB	Preamp dB	Level dBuV/m	Limit dBuV/m	Over limit	Remark
1	1423.30	39.80	26.10	4.21	36.64	33.47	74.00	-40.53	Peak
2	1902.64	40.83	25.81	4.89	37.17	34.36	74.00	-39.64	Peak
3	2376.00	40.68	27.75	5.51	37.23	36.71	74.00	-37.29	Peak
4	3568.51	47.83	29.34	6.87	36.99	47.05	74.00	-26.95	Peak
5	3698.71	47.18	29.40	7.01	37.16	46.43	74.00	-27.57	Peak
6	5495.69	35.41	31.88	9.34	32.40	44.23	74.00	-29.77	Peak

Polarization:

Vertical

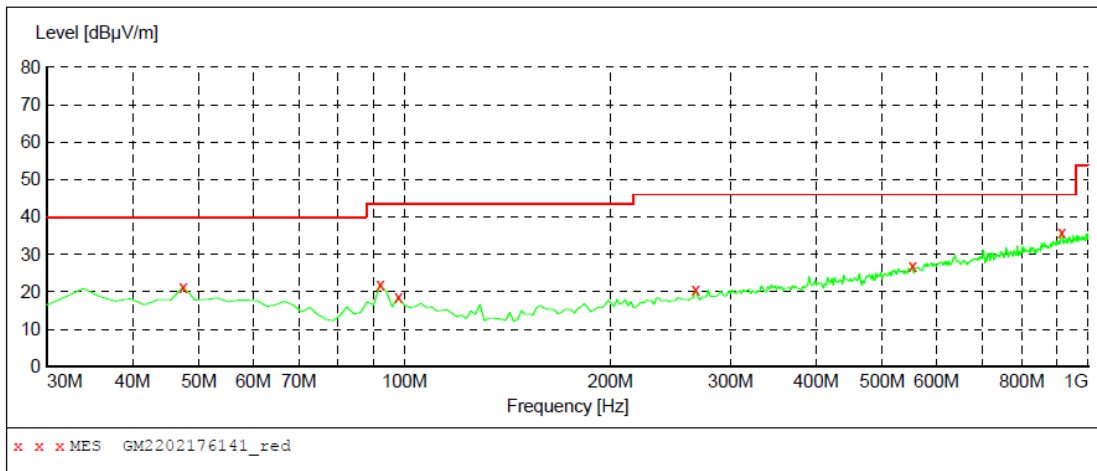

**MEASUREMENT RESULT: "GM2202176141\_red"**

2/18/2022 1:18AM

Frequency MHz	Level dBuV/m	Transd dB	Limit dBuV/m	Margin dB	Det.	Height cm	Azimuth deg	Polarization
47.460000	21.40	-8.8	40.0	18.6	QP	100.0	40.00	VERTICAL
92.080000	22.00	-12.1	43.5	21.5	QP	100.0	208.00	VERTICAL
97.900000	18.60	-11.1	43.5	24.9	QP	100.0	100.00	VERTICAL
266.680000	20.70	-8.1	46.0	25.3	QP	100.0	208.00	VERTICAL
553.800000	26.90	-0.6	46.0	19.1	QP	100.0	0.00	VERTICAL
914.640000	35.90	7.1	46.0	10.1	QP	100.0	234.00	VERTICAL

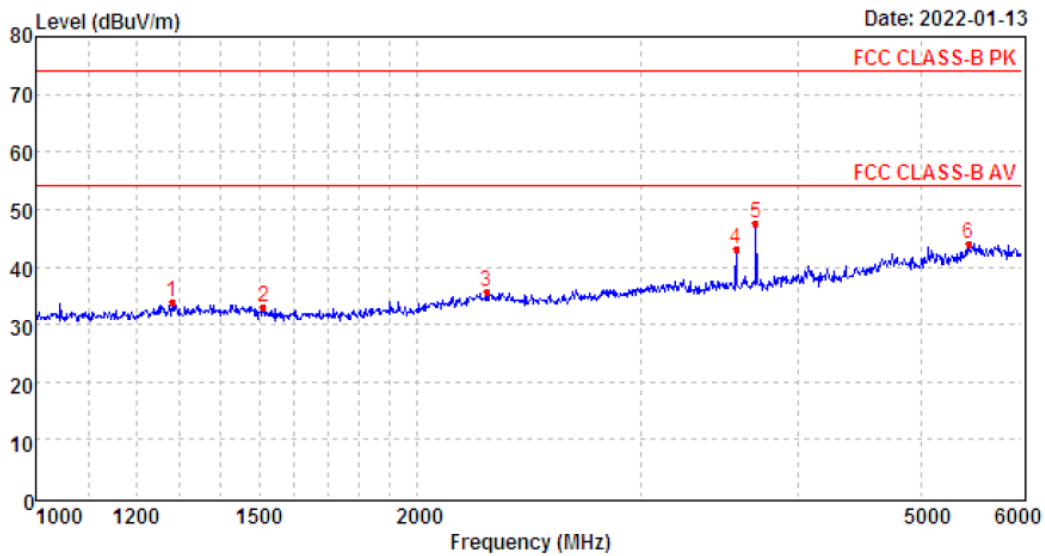

Mark	Frequency MHz	Reading dBuV/m	Antenna dB	Cable dB	Preamp dB	Level dBuV/m	Limit dBuV/m	Over limit	Remark
1	1280.52	40.62	25.96	4.00	36.67	33.91	74.00	-40.09	Peak
2	1512.70	39.86	25.80	4.34	36.92	33.08	74.00	-40.92	Peak
3	2267.85	39.62	28.06	5.38	37.41	35.65	74.00	-38.35	Peak
4	3568.51	43.91	29.34	6.87	36.99	43.13	74.00	-30.87	Peak
5	3698.71	48.30	29.40	7.01	37.16	47.55	74.00	-26.45	Peak
6	5446.67	35.76	31.70	9.35	32.81	44.00	74.00	-30.00	Peak

## 6. TEST SETUP PHOTOS OF THE EUT

### Conducted Emissions (AC Mains)

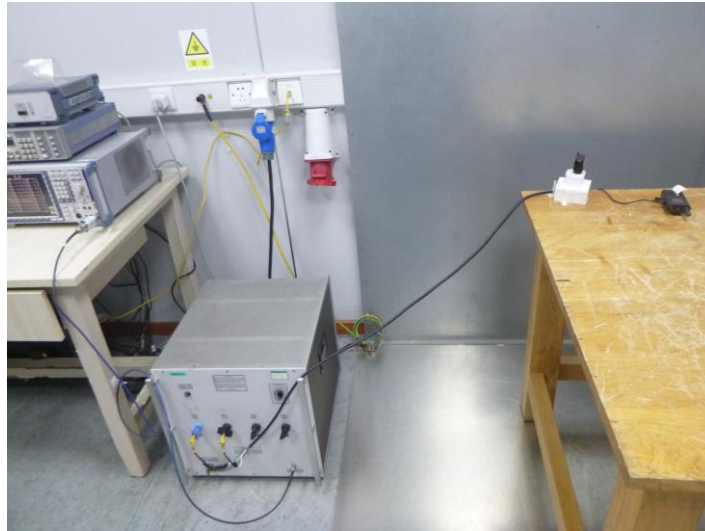

### Radiated Emissions (30MHz-1GHz)



### Radiated Emissions (Above 1GHz)

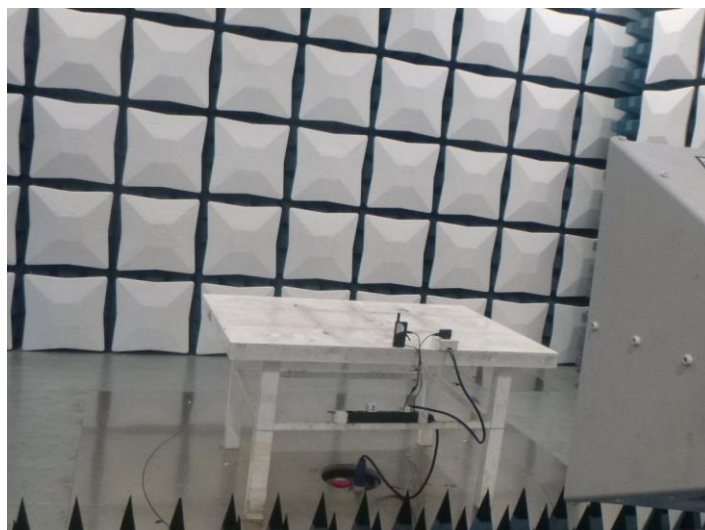

## **7. EXTERNAL AND INTERNAL PHOTOS OF THE EUT**

Please refer to the test report No.: CHTEW22040051

-----End of Report-----