

FCC TEST REPORT

FCC ID:2A3OF-NV007V

Report Number : ZKT-211118L6177
Date of Test : Nov. 10, 2021 -- Nov. 26, 2021
Date of issue..... : Nov. 26, 2021
Total number of pages : 68
Test Result..... : PASS

Testing Laboratory : Shenzhen ZKT Technology Co., Ltd.
Address : 1/F, No. 101, Building B, No. 6, Tangwei Community Industrial Avenue, Fuhai Street, Bao'an District, Shenzhen, China

Applicant's name : Shenzhen Pard Technology Co.,Ltd
Address : B78,18/F,Guangyin building,38 Futian South Road, port community, Futian street, Futian District, Shenzhen

Manufacturer's name : Shenzhen Pard Technology Co.,Ltd
Address : B78,18/F,Guangyin building,38 Futian South Road, port community, Futian street, Futian District, Shenzhen

Test specification:
Standard : FCC CFR Title 47 Part 15 Subpart C Section 15.247
ANSI C63.10:2013
KDB558074 D0115.247 Meas Guidance v 05r02
Test procedure : /

Test Report Form No. : TRF-EL-110_V0
Test Report Form(s) Originator : ZKT Testing
Master TRF : Dated: 2020-01-06

This device described above has been tested by ZKT, and the test results show that the equipment under test (EUT) is in compliance with the FCC requirements. And it is applicable only to the tested sample identified in the report.
This report shall not be reproduced except in full, without the written approval of ZKT, this document may be altered or revised by ZKT, personal only, and shall be noted in the revision of the document.

Product name..... : Night Vision
Trademark : PARD
Model/Type reference..... : NV007V, NV007V-850, NV007V-940, NV007B, NV007B-850, NV007B-940, NV007C, NV007C-850, NV007C-940, NV007X, NV007X-850, NV007X-940, NV007P, NV007P-850, NV007P-940

Ratings: DC 3.7V from battery
DC 5V 1A from adapter or others

Testing procedure and testing location:

Testing Laboratory: Shenzhen ZKT Technology Co., Ltd.
Address: 1/F, No. 101, Building B, No. 6, Tangwei Community
Industrial Avenue, Fuhai Street, Bao'an District, Shenzhen,
China

Tested by (name + signature).....: Alen He 

Reviewer (name + signature): Joe Liu 

Approved (name + signature).....: Lake Xie 

Table of Contents

	Page
1. VERSION	5
2. SUMMARY OF TEST RESULTS	6
2.1 TEST FACILITY	6
2.2 MEASUREMENT UNCERTAINTY	7
3. GENERAL INFORMATION	7
3.1 GENERAL DESCRIPTION OF EUT	7
3.2 DESCRIPTION OF TEST MODES	8
3.3 BLOCK DIGRAM SHOWING THE CONFIGURATION OF SYSTEM TESTED	9
3.4 DESCRIPTION OF SUPPORT UNITS(CONDUCTED MODE)	9
3.5EQUIPMENTS LIST FOR ALL TEST ITEMS	10
4. EMC EMISSION TEST	11
4.1 CONDUCTED EMISSION MEASUREMENT	11
4.1.1 POWER LINE CONDUCTED EMISSION LIMITS	11
4.1.2 TEST PROCEDURE	11
4.1.3 DEVIATION FROM TEST STANDARD	11
4.1.4 TEST SETUP	12
4.1.5 EUT OPERATING CONDITIONS	12
4.1.6 TEST RESULT	13
4.2 RADIATED EMISSION MEASUREMENT	15
4.2.1 RADIATED EMISSION LIMITS	15
4.2.2 TEST PROCEDURE	16
4.2.3 DEVIATION FROM TEST STANDARD	16
4.2.4 TEST SETUP	17
4.2.5 EUT OPERATING CONDITIONS	18
4.2.6 TEST RESULTS	19
5.RADIATED BAND EMISSIONMEASUREMENT	29
5.1 TEST REQUIREMENT:	29
5.2 TEST PROCEDURE	29
5.3 DEVIATION FROM TEST STANDARD	30
5.4 TEST SETUP	30
5.5 EUT OPERATING CONDITIONS	30
5.6 TEST RESULT	31
6.POWER SPECTRAL DENSITY TEST	34
6.1 APPLIED PROCEDURES / LIMIT	34

6.2 TEST PROCEDURE	34
6.3 DEVIATION FROM STANDARD	34
6.4 TEST SETUP	34
6.5 EUT OPERATION CONDITIONS	34
6.6 TEST RESULT	35
7. CHANNEL BANDWIDTH	43
7.1 APPLIED PROCEDURES / LIMIT	43
7.2 TEST PROCEDURE	43
7.3 DEVIATION FROM STANDARD	43
7.4 TEST SETUP	43
7.5 EUT OPERATION CONDITIONS	43
7.6 TEST RESULT	44
8. OUTPUT POWER TEST	47
8.1 APPLIED PROCEDURES/LIMIT	47
8.2 TEST PROCEDURE	47
8.3 DEVIATION FROM STANDARD	47
8.4 TEST SETUP	47
8.5 EUT OPERATION CONDITIONS	47
8.6 TEST RESULT	48
9. CONDUCTED BAND EDGE AND SPURIOUS EMISSION	49
9.1 APPLICABLE STANDARD	49
9.2 TEST PROCEDURE	49
9.3 DEVIATION FROM STANDARD	49
9.4 TEST SETUP	49
9.5 EUT OPERATION CONDITIONS	49
9.6 TEST RESULTS	49
10. ANTENNA REQUIREMENT	65
11. TEST SETUP PHOTO	66
12. EUT CONSTRUCTIONAL DETAILS	68

1. VERSION

Report No.	Version	Description	Approved
ZKT-211118L6177	Rev.01	Initial issue of report	Nov. 26, 2021

2. SUMMARY OF TEST RESULTS

Test procedures according to the technical standards:

FCC Part15 (15.247) , Subpart C			
Standard Section	Test Item	Result	Remark
FCC part 15.203/15.247 (c)	Antenna requirement	PASS	
FCC part 15.207	AC Power Line Conducted Emission	PASS	
FCC part 15.247 (b)(3)	Conducted Peak Output Power	PASS	
FCC part 15.247 (a)(2)	Channel Bandwidth& 99% OCB	PASS	
FCC part 15.247 (e)	Power Spectral Density	PASS	
FCC part 15.247(d)	Band Edge	PASS	
FCC part 15.205/15.209	Spurious Emission	PASS	

NOTE:

(1)" N/A" denotes test is not applicable in this Test Report

2.1 TEST FACILITY

Shenzhen ZKT Technology Co., Ltd.

Add. : 1/F, No. 101, Building B, No. 6, Tangwei Community Industrial Avenue, Fuhai Street, Bao'an District, Shenzhen, China

FCC Test Firm Registration Number: 692225

Designation Number: CN1299

IC Registered No.: 27033

1	2412MHz	4	2427MHz	7	2442MHz	10	2457MHz
2	2417MHz	5	2432MHz	8	2447MHz	11	2462MHz
3	2422MHz	6	2437MHz	9	2452MHz	X	

Note:

In section 15.31(m), regards to the operating frequency range over 10 MHz, the Lowest frequency, the middle frequency, and the highest frequency of channel were selected to perform the test, and the selected channel see below:

Test channel	Frequency (MHz)
	802.11b/802.11g/802.11n(HT20)
Lowest channel	2412MHz
Middle channel	2437MHz
Highest channel	2462MHz

Test channel	Frequency (MHz)
	802.11n(HT40)
Lowest channel	2422MHz
Middle channel	2437MHz
Highest channel	2452MHz

3.2 DESCRIPTION OF TEST MODES

Transmitting mode	Keep the EUT in continuously transmitting mode
Remark: During the test, the duty cycle >98%, the test voltage was tuned from 85% to 115% of the nominal rated supply voltage, and found that the worst case was under the nominal rated supply condition. So the report just shows that condition's data.	

We have verified the construction and function in typical operation. All the test modes were carried out with the EUT in transmitting operation, which was shown in this test report and defined as follows:				
Pre-scan all kind of data rate in lowest channel, and found the follow list which it was worst case.				
Mode	802.11b	802.11g	802.11n(HT20)	802.11n(HT40)
Data rate	1Mbps	6Mbps	6.5Mbps	MCS0

Test Software	Realtek Test Tool
Power level setup	<20dBm

3.3 BLOCK DIGRAM SHOWING THE CONFIGURATION OF SYSTEM TESTED

Conducted Emission

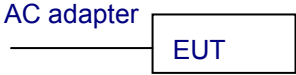

Radiated Emission



Conducted Spurious



3.4 DESCRIPTION OF SUPPORT UNITS(CONDUCTED MODE)

The EUT has been tested as an independent unit together with other necessary accessories or support units. The following support units or accessories were used to form a representative test configuration during the tests.

Item	Equipment	Mfr/Brand	Model/Type No.	Series No.	Note
1	ADAPTER	HUAWEI	HW-100100C01	/	SDOC

Item	Shielded Type	Ferrite Core	Length	Note

Note:

- (1) The support equipment was authorized by Declaration of Confirmation.
- (2) For detachable type I/O cable should be specified the length in cm in 『Length』 column.

3.5EQUIPMENTS LIST FOR ALL TEST ITEMS

Radiation Test equipment

Item	Equipment	Manufacturer	Type No.	Serial No.	Last calibration	Calibrated until
1	Spectrum Analyzer (9kHz-26.5GHz)	KEYSIGHT	9020A	MY45109572	Sep. 21, 2021	Sep. 20, 2022
2	Spectrum Analyzer (1GHz-40GHz)	Agilent	E4446A	100363	Sep. 21, 2021	Sep. 20, 2022
3	Test Receiver (9kHz-7GHz)	R&S	ESC17	101169	Sep. 21, 2021	Sep. 20, 2022
4	Bilog Antenna (30MHz-1400MHz)	Schwarzbeck	VULB9168	00877	Sep. 21, 2021	Sep. 20, 2022
5	Horn Antenna (1GHz-18GHz)	SCHWARZBEC K	BBHA9120D	1541	Sep. 21, 2021	Sep. 20, 2022
6	Horn Antenna (18GHz-40GHz)	A.H. System	SAS-574	588	Sep. 21, 2021	Sep. 20, 2022
7	Amplifier (30-1000MHz)	EM Electronics	EM330 Amplifier	N/A	Sep. 21, 2021	Sep. 20, 2022
8	Amplifier (1GHz-40GHz)	QUANJUDA	DLE-161	097	Sep. 21, 2021	Sep. 20, 2022
9	Loop Antenna (9KHz-30MHz)	SCHWARZBEC K	FMZB1519B	014	Sep. 21, 2021	Sep. 20, 2022
10	RF cables1 (9kHz-30MHz)	N/A	9kHz-30MHz	N/A	Sep. 21, 2021	Sep. 20, 2022
11	RF cables2 (30MHz-1GHz)	N/A	30MHz-1GHz	N/A	Sep. 21, 2021	Sep. 20, 2022
12	RF cables3 (1GHz-40GHz)	N/A	1GHz-40GHz	N/A	Sep. 21, 2021	Sep. 20, 2022
13	CMW500 Test	R&S	CMW500	106504	Sep. 21, 2021	Sep. 20, 2022
14	ESG Signal Generator	Agilent	E4421B	GB40051203	Sep. 21, 2021	Sep. 20, 2022
15	Signal Generator	Agilent	N5182A	MY47420215	Sep. 21, 2021	Sep. 20, 2022
16	D.C. Power Supply	LongWei	TPR-6405D	\	\	\
17	Software	Frad	EZ-EMC	FA-03A2 RE	\	\

Conduction Test equipment

Item	Kind of Equipment	Manufacturer	Type No.	Serial No.	Last calibration	Calibrated until
1	LISN	R&S	ENV216	101471	Sep. 21, 2021	Sep. 20, 2022
2	LISN	CYBERTEK	EM5040A	E1850400149	Sep. 21, 2021	Sep. 20, 2022
3	Test Cable	N/A	C01	N/A	Sep. 21, 2021	Sep. 20, 2022
4	Test Cable	N/A	C02	N/A	Sep. 21, 2021	Sep. 20, 2022
5	EMI Test Receiver	R&S	ESRP3	101946	Sep. 21, 2021	Sep. 20, 2022
6	Absorbing Clamp	DZ	ZN23201	N/A	Sep. 21, 2021	Sep. 20, 2022

4. EMC EMISSION TEST

4.1 CONDUCTED EMISSION MEASUREMENT

Test Requirement:	FCC Part15 C Section 15.207
Test Method:	ANSI C63.10:2013
Test Frequency Range:	150KHz to 30MHz
Receiver setup:	RBW=9KHz, VBW=30KHz, Sweep time=auto

4.1.1 POWER LINE CONDUCTED EMISSION LIMITS

FREQUENCY (MHz)	Limit (dBuV)		Standard
	Quasi-peak	Average	
0.15 -0.5	66 - 56 *	56 - 46 *	FCC
0.50 -5.0	56.00	46.00	FCC
5.0 -30.0	60.00	50.00	FCC

Note:

(1) *Decreases with the logarithm of the frequency.

4.1.2 TEST PROCEDURE

1. The equipment was set up as per the test configuration to simulate typical actual usage per the user's manual. The EUT is a tabletop system; a wooden table with a height of 0.8 meters is used and is placed on the ground plane as per ANSI C63.10:2013.
2. Support equipment, if needed, was placed as per ANSI C63.10:2013
3. All I/O cables were positioned to simulate typical actual usage as per ANSI C63.10:2013.
4. The adapter received AC120V/60Hz power through a Line Impedance Stabilization Network (LISN) which supplied power source and was grounded to the ground plane.
5. All support equipments received AC power from a second LISN, if any.
6. The EUT test program was started. Emissions were measured on each current carrying line of the EUT using a spectrum Analyzer / Receiver connected to the LISN powering the EUT. The LISN has two monitoring points: Line 1 (Hot Side) and Line 2 (Neutral Side). Two scans were taken: one with Line 1 connected to Analyzer / Receiver and Line 2 connected to a 50 ohm load; the second scan had Line 1 connected to a 50 ohm load and Line 2 connected to the Analyzer / Receiver.
7. Analyzer / Receiver scanned from 150 KHz to 30MHz for emissions in each of the test modes.e.
- 8 For the actual test configuration, please refer to the related Item –EUT Test Photos.

4.1.3 DEVIATION FROM TEST STANDARD

No deviation

4.1.4 TEST SETUP

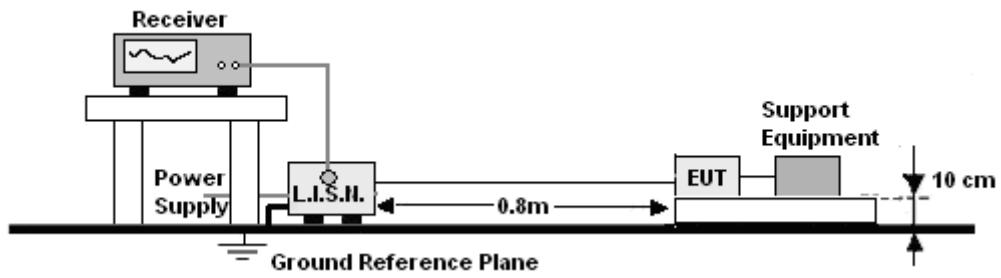

4.1.5 EUT OPERATING CONDITIONS

The EUT was configured for testing in a typical fashion (as a customer would normally use it). The EUT has been programmed to continuously transmit during test. This operating condition was tested and used to collect the included data.

We pretest AC 120V, the worst voltage was AC 120V and the data recording in the report.

4.1.6 TEST RESULT

Temperature :	26°C	Relative Humidity:	54%
Pressure :	101kPa	Phase :	L
Test Voltage :	AC 120V/60Hz		

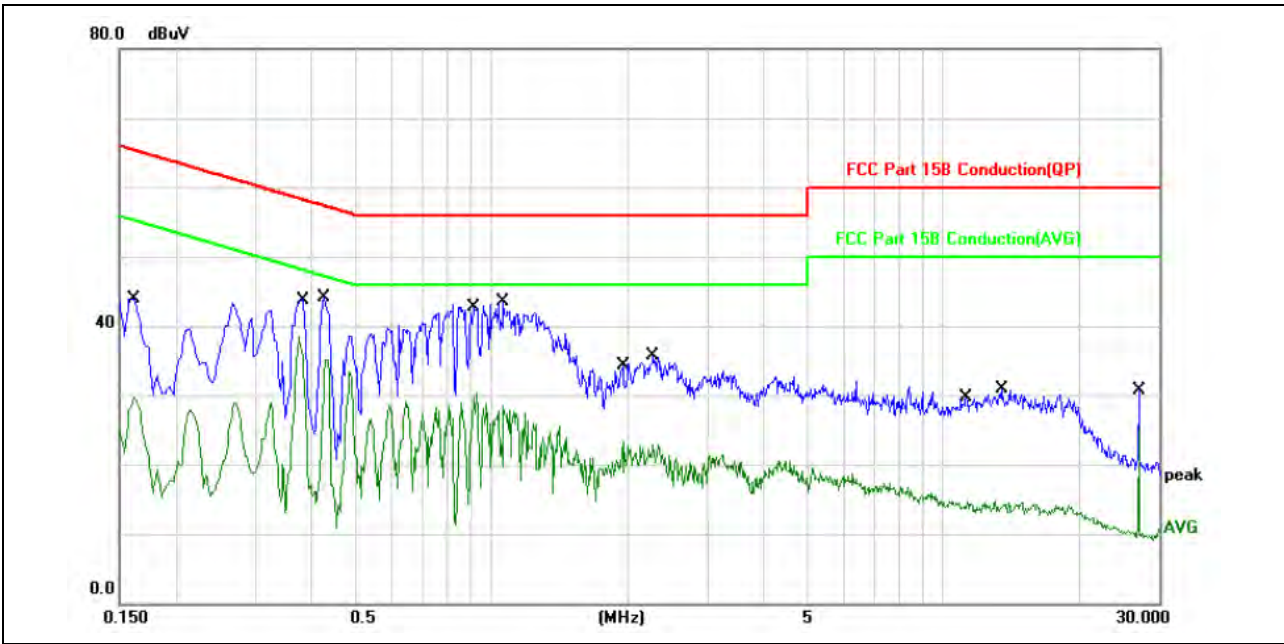

No.	Mk.	Freq.	Reading Level	Correct Factor	Measurement	Limit	Over	Detector	Comment
		MHz	dBuV	dB	dBuV	dBuV	dB		
1		0.1620	34.23	9.75	43.98	65.36	-21.38	QP	
2		0.1620	19.91	9.75	29.66	55.36	-25.70	AVG	
3	*	0.3740	28.67	9.86	38.53	48.41	-9.88	AVG	
4		0.4260	34.23	9.86	44.09	57.33	-13.24	QP	
5		0.9260	20.57	9.77	30.34	46.00	-15.66	AVG	
6		1.0620	33.73	9.75	43.48	56.00	-12.52	QP	
7		1.9580	13.59	9.65	23.24	46.00	-22.76	AVG	
8		2.2820	25.98	9.63	35.61	56.00	-20.39	QP	
9		11.3100	4.96	9.77	14.73	50.00	-35.27	AVG	
10		13.4780	21.18	9.74	30.92	60.00	-29.08	QP	
11		26.9980	21.10	9.50	30.60	60.00	-29.40	QP	
12		26.9980	15.85	9.50	25.35	50.00	-24.65	AVG	

Notes:

1. An initial pre-scan was performed on the line and neutral lines with peak detector.
2. Quasi-Peak and Average measurement were performed at the frequencies with maximized peak emission.
3. Measurement Level = Reading level + Correct Factor

Temperature :	26°C	Relative Humidity:	54%
Pressure :	101kPa	Phase :	N
Test Voltage :	AC 120V/60Hz		

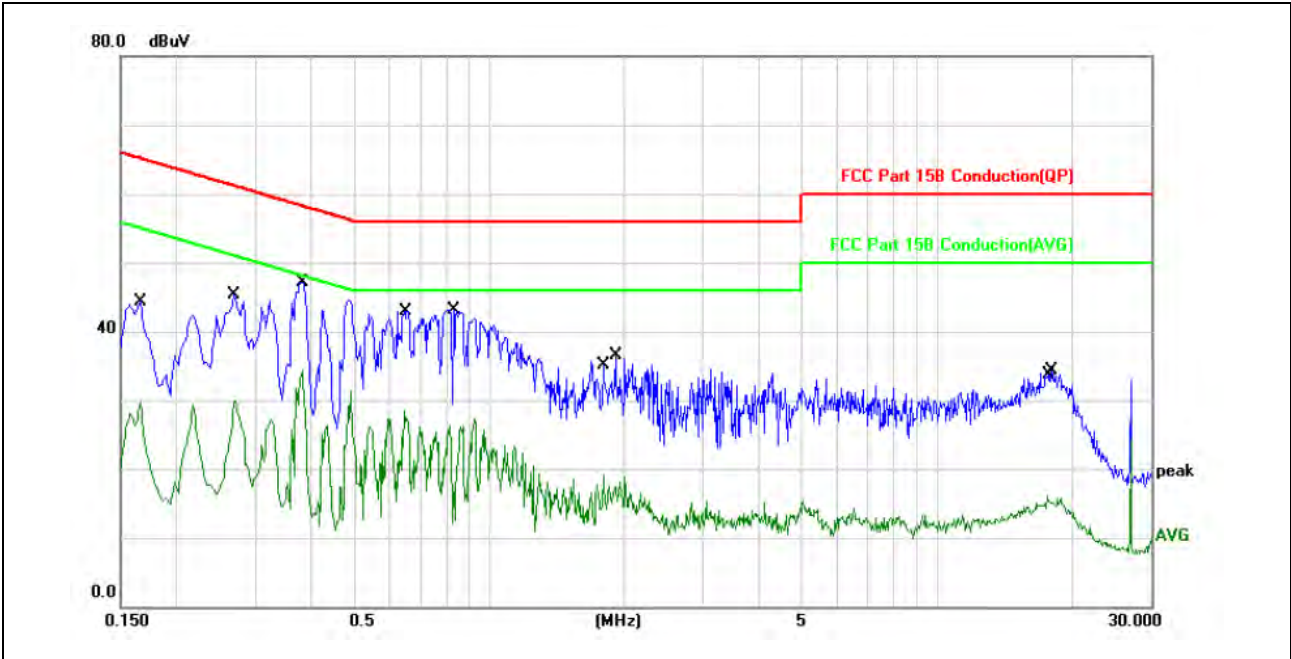

No.	Mk.	Freq. MHz	Reading Level dBuV	Correct Factor dB	Measure- ment dBuV	Limit dBuV	Over dB	Detector	Comment
1		0.1660	34.54	9.75	44.29	65.15	-20.86	QP	
2		0.1660	20.03	9.75	29.78	55.15	-25.37	AVG	
3		0.2700	35.43	9.81	45.24	61.12	-15.88	QP	
4		0.2700	20.16	9.81	29.97	51.12	-21.15	AVG	
5	*	0.3820	37.25	9.87	47.12	58.23	-11.11	QP	
6		0.3820	24.46	9.87	34.33	48.23	-13.90	AVG	
7		0.6460	18.69	9.83	28.52	46.00	-17.48	AVG	
8		0.8340	33.37	9.80	43.17	56.00	-12.83	QP	
9		1.7940	9.37	9.67	19.04	46.00	-26.96	AVG	
10		1.9100	26.91	9.66	36.57	56.00	-19.43	QP	
11		17.6100	6.54	9.59	16.13	50.00	-33.87	AVG	
12		17.9980	24.77	9.58	34.35	60.00	-25.65	QP	

Notes:

- 1.An initial pre-scan was performed on the line and neutral lines with peak detector.
- 2.Quasi-Peak and Average measurement were performed at the frequencies with maximized peak emission.
- 3.Measurement Level = Reading level + Correct Factor

4.2 RADIATED EMISSION MEASUREMENT

Test Requirement:	FCC Part15 C Section 15.209				
Test Method:	ANSI C63.10:2013				
Test Frequency Range:	9kHz to 25GHz				
Test site:	Measurement Distance: 3m				
Receiver setup:	Frequency	Detector	RBW	VBW	Value
	9KHz-150KHz	Quasi-peak	200Hz	600Hz	Quasi-peak
	150KHz-30MHz	Quasi-peak	9KHz	30KHz	Quasi-peak
	30MHz-1GHz	Quasi-peak	100KHz	300KHz	Quasi-peak
	Above 1GHz	Peak	1MHz	3MHz	Peak
		Peak	1MHz	10Hz	Average

4.2.1 RADIATED EMISSION LIMITS

Frequencies (MHz)	Field Strength (micorvolts/meter)	Measurement Distance (meters)
0.009~0.490	2400/F(KHz)	300
0.490~1.705	24000/F(KHz)	30
1.705~30.0	30	30
30~88	100	3
88~216	150	3
216~960	200	3
Above 960	500	3

LIMITS OF RADIATED EMISSION MEASUREMENT

FREQUENCY (MHz)	Limit (dBuV/m) (at 3M)	
	PEAK	AVERAGE
Above 1000	74	54

Notes:

- (1) The limit for radiated test was performed according to FCC PART 15C.
- (2) The tighter limit applies at the band edges.
- (3) Emission level (dBuV/m)=20log Emission level (uV/m).

4.2.2 TEST PROCEDURE

Below 1GHz test procedure as below:

- a. The EUT was placed on the top of a rotating table 0.1 meters above the ground at a 3 meter semi-anechoic chamber. The table was rotated 360 degrees to determine the position of the highest radiation.
- b. The EUT was set 3 meters away from the interference-receiving antenna, which was mounted on the top of a variable-height antenna tower.
- c. The antenna height is varied from one meter to four meters above the ground to determine the maximum value of the field strength. Both horizontal and vertical polarizations of the antenna are set to make the measurement.
- d. For each suspected emission, the EUT was arranged to its worst case and then the antenna was tuned to heights from 1 meter to 4 meters (for the test frequency of below 30MHz, the antenna was tuned to heights 1 meter) and the rotatable table was turned from 0 degrees to 360 degrees to find the maximum reading.
- e. The test-receiver system was set to Peak Detect Function and Specified Bandwidth with Maximum Hold Mode.
- f. If the emission level of the EUT in peak mode was 10dB lower than the limit specified, then testing could be stopped and the peak values of the EUT would be reported. Otherwise the emissions that did not have 10dB margin would be re-tested one by one using peak, quasi-peak or average method as specified and then reported in a data sheet.

Above 1GHz test procedure as below:

- g. Different between above is the test site, change from Semi- Anechoic Chamber to fully Anechoic Chamber and change from table 0.8 metre to 1.5 metre (Above 18GHz the distance is 1 meter and table is 1.5 metre).
- h. Test the EUT in the lowest channel, the middle channel, the Highest channel

Note:

Both horizontal and vertical antenna polarities were tested and performed pretest to three orthogonal axis. The worst case emissions were reported

4.2.3 DEVIATION FROM TEST STANDARD

No deviation

4.2.4 TEST SETUP

(A) Radiated Emission Test-Up Frequency Below 30MHz

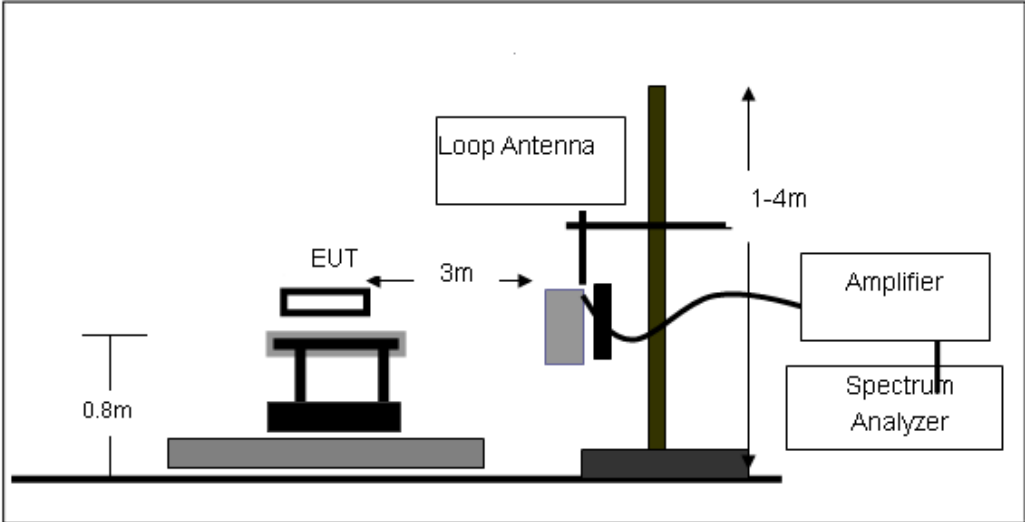

(B) Radiated Emission Test-Up Frequency 30MHz~1GHz

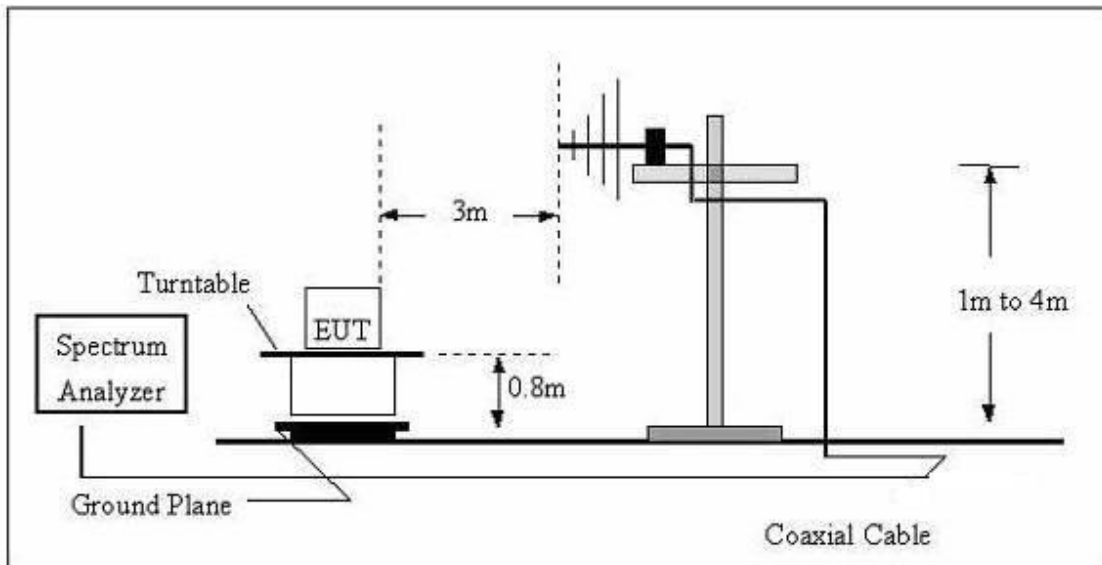

(C) Radiated Emission Test-Up Frequency Above 1GHz

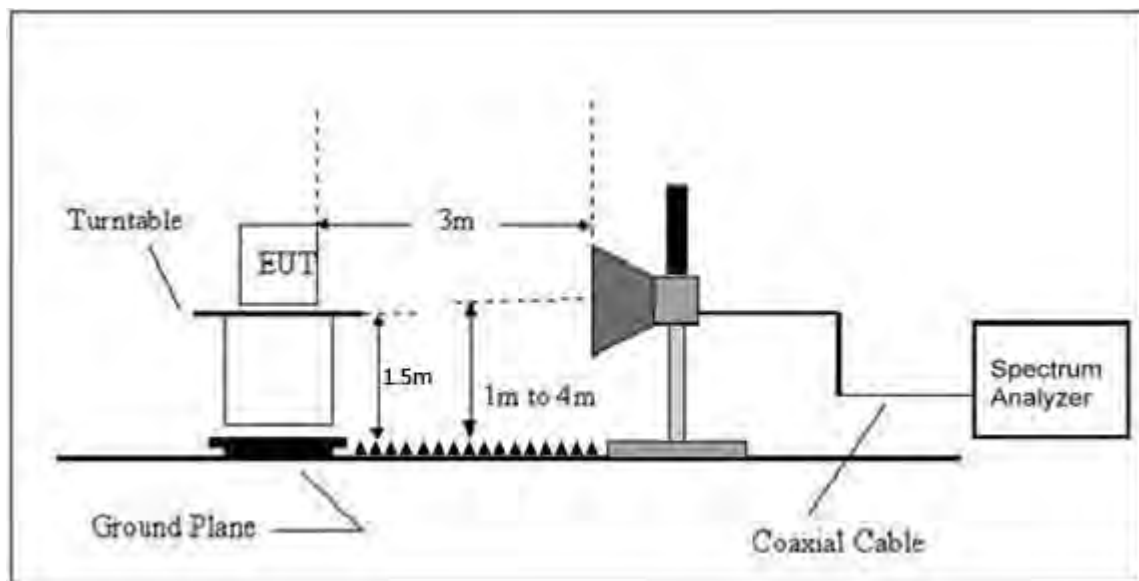

4.2.5 EUT OPERATING CONDITIONS

The EUT tested system was configured as the statements of 2.4 Unless otherwise a special operating condition is specified in the follows during the testing.

4.2.6 TEST RESULTS

Between 9KHz – 30MHz

The emission from 9 kHz to 30MHz was pre-tested and found the result was 20dB lower than the limit, and according to 15.31(o) & RSS-Gen 6.13, the test result no need to reported.

Between 30MHz – 1GHz

Temperature:	26°C	Relative Humidity:	54%
Pressure:	101 kPa	Polarization:	Horizontal
Test Voltage:	AC 120V/60Hz		

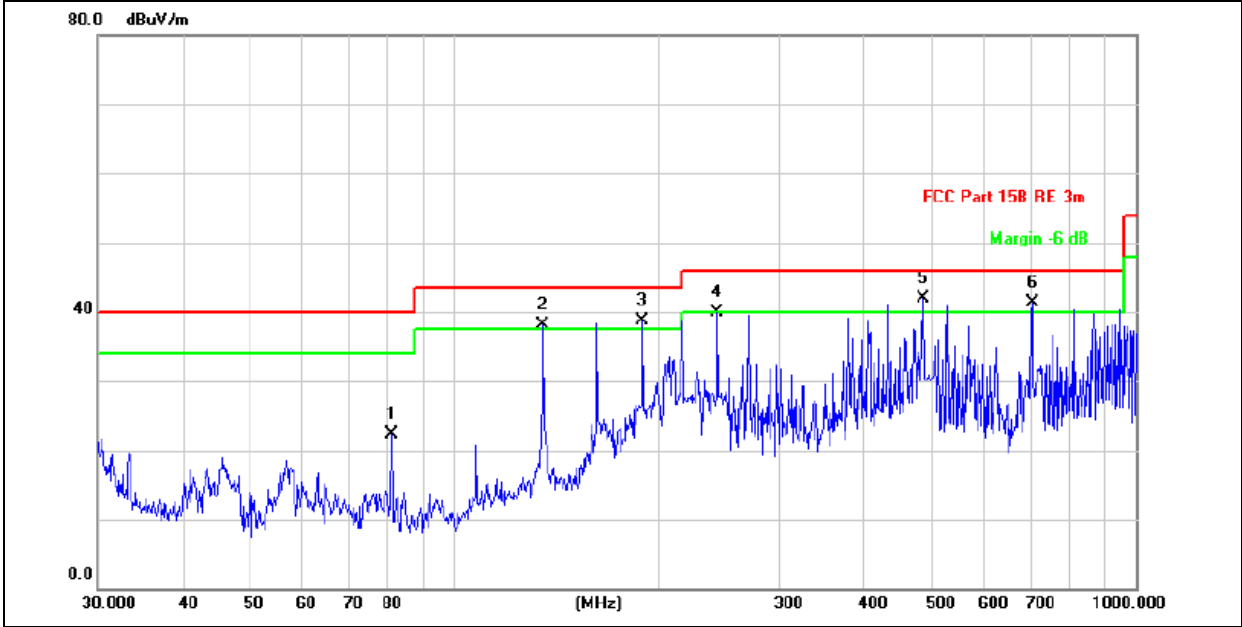

No.	Mk.	Freq. MHz	Reading Level dBuV	Correct Factor dB/m	Measure- ment dBuV/m	Limit dBuV/m	Over dB	Detector	Antenna Height cm	Table Degree	Comment
1		80.9274	36.00	-13.66	22.34	40.00	-17.66	QP	100	180	
2	!	135.0319	43.45	-5.30	38.15	43.50	-5.35	QP	300	360	
3	!	189.0741	45.78	-7.04	38.74	43.50	-4.76	QP	300	360	
4		243.3771	45.95	-6.06	39.89	46.00	-6.11	QP	300	180	
5	*	487.3149	41.93	0.03	41.96	46.00	-4.04	QP	100	180	
6	!	704.2259	39.24	1.98	41.22	46.00	-4.78	QP	300	360	

Temperature:	26°C	Relative Humidity:	54%
Pressure:	101kPa	Polarization:	Vertical
Test Voltage:	AC 120V/60Hz		

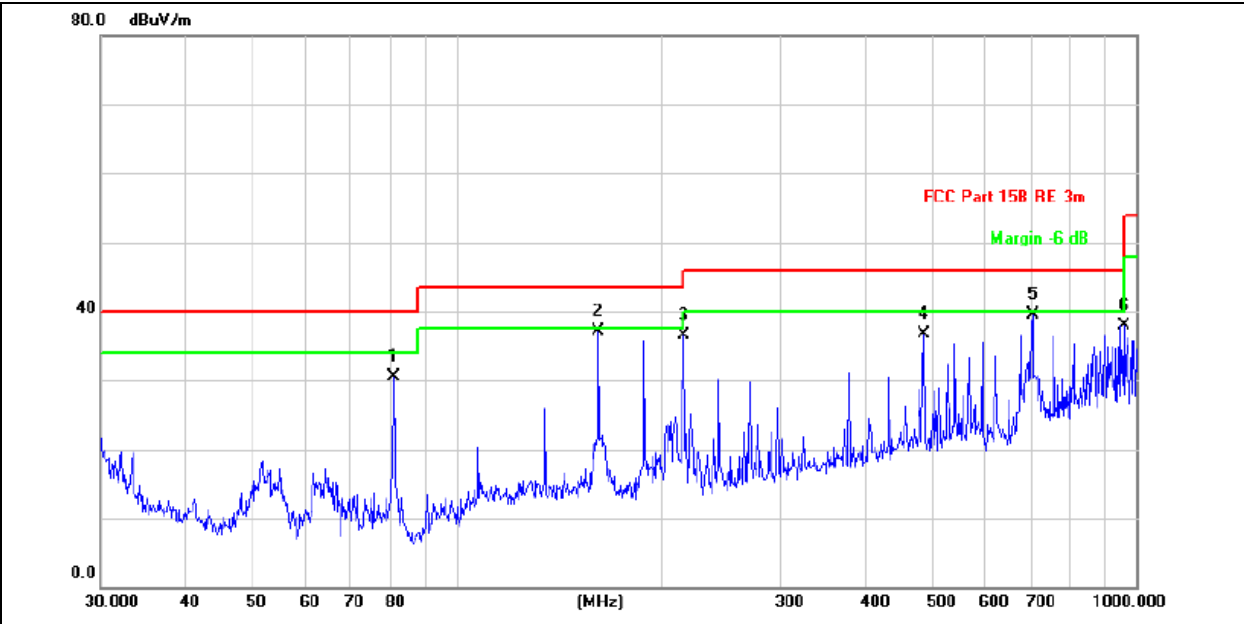

No.	Mk.	Freq.	Reading Level	Correct Factor	Measurement	Limit	Over	Antenna Height	Table Degree	
		MHz	dBuV	dB/m	dBuV/m	dBuV/m	dB	cm	degree	Comment
1		80.9274	44.07	-13.66	30.41	40.00	-9.59	QP	100	360
2	*	162.0414	42.97	-5.83	37.14	43.50	-6.36	QP	100	180
3		216.0240	43.69	-7.11	36.58	46.00	-9.42	QP	100	180
4		487.3149	36.62	0.03	36.65	46.00	-9.35	QP	100	360
5		704.2259	37.49	1.98	39.47	46.00	-6.53	QP	100	180
6		958.7943	31.08	6.85	37.93	46.00	-8.07	QP	100	360

Remarks:

1. Final Level = Receiver Read level + Antenna Factor + Cable Loss – Preamplifier Factor
2. The emission levels of other frequencies are very lower than the limit and not show in test report.
3. The test data shows only the worst case 802.11b mode

1GHz~25GHz

802.11b

Polar (H/V)	Frequency	Meter Reading	Pre-ampl ifier	Cable Loss	Antenna Factor	Emission Level	Limits	Margin	Detect or Type
	(MHz)	(dBuV)	(dB)	(dB)	(dB)	(dBuV/m)	(dBuV/ m)	(dB)	
Low Channel:2412MHz									
V	4824	57.05	30.55	5.77	24.66	56.93	74	-17.07	PK
V	4824	41.13	30.55	5.77	24.66	41.01	54	-12.99	AV
V	7236	54.00	30.33	6.32	24.55	54.54	74	-19.46	PK
V	7236	42.47	30.33	6.32	24.55	43.01	54	-10.99	AV
V	9648	55.46	30.85	7.45	24.69	56.75	74	-17.25	PK
V	9648	40.51	30.85	7.45	24.69	41.80	54	-12.20	AV
H	4824	54.79	30.55	5.77	24.66	54.67	74	-19.33	PK
H	4824	42.36	30.55	5.77	24.66	42.24	54	-11.76	AV
H	7236	53.94	30.33	6.32	24.55	54.48	74	-19.52	PK
H	7236	42.02	30.33	6.32	24.55	42.56	54	-11.44	AV
H	9648	55.17	30.85	7.45	24.69	56.46	74	-17.54	PK
H	9648	40.65	30.85	7.45	24.69	41.94	54	-12.06	AV

Polar (H/V)	Frequency	Meter Reading	Pre-ampl ifier	Cable Loss	Antenna Factor	Emission Level	Limits	Margin	Detect or Type
	(MHz)	(dBuV)	(dB)	(dB)	(dB)	(dBuV/m)	(dBuV/ m)	(dB)	
Middle Channel:2437MHz									
V	4874	56.71	30.55	5.77	24.66	56.59	74	-17.41	PK
V	4874	41.71	30.55	5.77	24.66	41.59	54	-12.41	AV
V	7311	54.46	30.33	6.32	24.55	55.00	74	-19.00	PK
V	7311	42.43	30.33	6.32	24.55	42.97	54	-11.03	AV
V	9748	55.18	30.85	7.45	24.69	56.47	74	-17.53	PK
V	9748	42.67	30.85	7.45	24.69	43.96	54	-10.04	AV
H	4874	55.72	30.55	5.77	24.66	55.60	74	-18.40	PK
H	4874	43.13	30.55	5.77	24.66	43.01	54	-10.99	AV
H	7311	54.72	30.33	6.32	24.55	55.26	74	-18.74	PK
H	7311	40.59	30.33	6.32	24.55	41.13	54	-12.87	AV
H	9748	52.93	30.85	7.45	24.69	54.22	74	-19.78	PK
H	9748	40.25	30.85	7.45	24.69	41.54	54	-12.46	AV

Polar (H/V)	Frequency (MHz)	Meter Reading (dBuV)	Pre-ampli fier (dB)	Cable Loss (dB)	Antenna Factor (dB)	Emission Level (dBuV/m)	Limits (dBuV/ m)	Margin (dB)	Detect or Type
High Channel:2462MHz									
V	4924	54.98	30.55	5.77	24.66	54.86	74	-19.14	PK
V	4924	41.66	30.55	5.77	24.66	41.54	54	-12.46	AV
V	7386	54.56	30.33	6.32	24.55	55.10	74	-18.90	PK
V	7386	43.61	30.33	6.32	24.55	44.15	54	-9.85	AV
V	9848	55.26	30.85	7.45	24.69	56.55	74	-17.45	PK
V	9848	42.43	30.85	7.45	24.69	43.72	54	-10.28	AV
H	4924	54.30	30.55	5.77	24.66	54.18	74	-19.82	PK
H	4924	42.23	30.55	5.77	24.66	42.11	54	-11.89	AV
H	7386	53.35	30.33	6.32	24.55	53.89	74	-20.11	PK
H	7386	42.35	30.33	6.32	24.55	42.89	54	-11.11	AV
H	9848	55.47	30.85	7.45	24.69	56.76	74	-17.24	PK
H	9848	41.01	30.85	7.45	24.69	42.30	54	-11.70	AV

Remark:

1. Emission Level = Meter Reading + Antenna Factor + Cable Loss – Pre-amplifier,
Margin= Emission Level - Limit
2. If peak below the average limit, the average emission was no test.
3. The amplitude of spurious emissions which are attenuated by more than 20dB below the permissible value has no need to be reported.

802.11g

Polar (H/V)	Frequency	Meter Reading	Pre-ampl ifier	Cable Loss	Antenna Factor	Emission Level	Limits	Margin	Detect or Type
	(MHz)	(dBuV)	(dB)	(dB)	(dB)	(dBuV/m)	(dBuV/ m)	(dB)	
Low Channel:2412MHz									
V	4824	55.34	30.55	5.77	24.66	55.22	74	-18.78	PK
V	4824	41.62	30.55	5.77	24.66	41.50	54	-12.50	AV
V	7236	54.45	30.33	6.32	24.55	54.99	74	-19.01	PK
V	7236	44.54	30.33	6.32	24.55	45.08	54	-8.92	AV
V	9648	54.21	30.85	7.45	24.69	55.50	74	-18.50	PK
V	9648	41.68	30.85	7.45	24.69	42.97	54	-11.03	AV
H	4824	57.32	30.55	5.77	24.66	57.20	74	-16.80	PK
H	4824	42.62	30.55	5.77	24.66	42.50	54	-11.50	AV
H	7236	53.66	30.33	6.32	24.55	54.20	74	-19.80	PK
H	7236	40.82	30.33	6.32	24.55	41.36	54	-12.64	AV
H	9648	54.65	30.85	7.45	24.69	55.94	74	-18.06	PK
H	9648	40.95	30.85	7.45	24.69	42.24	54	-11.76	AV

Polar (H/V)	Frequency	Meter Reading	Pre-ampl ifier	Cable Loss	Antenna Factor	Emission Level	Limits	Margin	Detect or Type
	(MHz)	(dBuV)	(dB)	(dB)	(dB)	(dBuV/m)	(dBuV/ m)	(dB)	
Middle Channel:2437MHz									
V	4874	56.08	30.55	5.77	24.66	55.96	74	-18.04	PK
V	4874	42.15	30.55	5.77	24.66	42.03	54	-11.97	AV
V	7311	53.47	30.33	6.32	24.55	54.01	74	-19.99	PK
V	7311	42.57	30.33	6.32	24.55	43.11	54	-10.89	AV
V	9748	54.23	30.85	7.45	24.69	55.52	74	-18.48	PK
V	9748	41.53	30.85	7.45	24.69	42.82	54	-11.18	AV
H	4874	55.34	30.55	5.77	24.66	55.22	74	-18.78	PK
H	4874	43.06	30.55	5.77	24.66	42.94	54	-11.06	AV
H	7311	52.88	30.33	6.32	24.55	53.42	74	-20.58	PK
H	7311	40.45	30.33	6.32	24.55	40.99	54	-13.01	AV
H	9748	55.28	30.85	7.45	24.69	56.57	74	-17.43	PK
H	9748	40.29	30.85	7.45	24.69	41.58	54	-12.42	AV

Polar (H/V)	Frequency	Meter Reading	Pre-ampl ifier	Cable Loss	Antenna Factor	Emission Level	Limits	Margin	Detect or Type
	(MHz)	(dBuV)	(dB)	(dB)	(dB)	(dBuV/m)	(dBuV/ m)	(dB)	
High Channel:2462MHz									
V	4924	57.09	30.55	5.77	24.66	56.97	74	-17.03	PK
V	4924	40.83	30.55	5.77	24.66	40.71	54	-13.29	AV
V	7386	52.81	30.33	6.32	24.55	53.35	74	-20.65	PK
V	7386	43.65	30.33	6.32	24.55	44.19	54	-9.81	AV
V	9848	53.30	30.85	7.45	24.69	54.59	74	-19.41	PK
V	9848	40.89	30.85	7.45	24.69	42.18	54	-11.82	AV
H	4924	53.91	30.55	5.77	24.66	53.79	74	-20.21	PK
H	4924	42.70	30.55	5.77	24.66	42.58	54	-11.42	AV
H	7386	53.18	30.33	6.32	24.55	53.72	74	-20.28	PK
H	7386	42.60	30.33	6.32	24.55	43.14	54	-10.86	AV
H	9848	55.43	30.85	7.45	24.69	56.72	74	-17.28	PK
H	9848	41.07	30.85	7.45	24.69	42.36	54	-11.64	AV

Remark:

1. Emission Level = Meter Reading + Antenna Factor + Cable Loss – Pre-amplifier, Margin= Emission Level - Limit
2. If peak below the average limit, the average emission was no test.
3. The amplitude of spurious emissions which are attenuated by more than 20dB below the permissible value has no need to be reported.

802.11n20

Polar (H/V)	Frequency	Meter Reading	Pre-ampl ifier	Cable Loss	Antenna Factor	Emission Level	Limits	Margin	Detect or Type
	(MHz)	(dBuV)	(dB)	(dB)	(dB)	(dBuV/m)	(dBuV/ m)	(dB)	
Low Channel:2412MHz									
V	4824	56.15	30.55	5.77	24.66	56.03	74	-17.97	PK
V	4824	42.54	30.55	5.77	24.66	42.42	54	-11.58	AV
V	7236	53.43	30.33	6.32	24.55	53.97	74	-20.03	PK
V	7236	43.57	30.33	6.32	24.55	44.11	54	-9.89	AV
V	9648	53.57	30.85	7.45	24.69	54.86	74	-19.14	PK
V	9648	43.21	30.85	7.45	24.69	44.50	54	-9.50	AV
H	4824	57.58	30.55	5.77	24.66	57.46	74	-16.54	PK
H	4824	43.04	30.55	5.77	24.66	42.92	54	-11.08	AV
H	7236	53.07	30.33	6.32	24.55	53.61	74	-20.39	PK

H	7236	40.55	30.33	6.32	24.55	41.09	54	-12.91	AV
H	9648	55.02	30.85	7.45	24.69	56.31	74	-17.69	PK
H	9648	40.45	30.85	7.45	24.69	41.74	54	-12.26	AV

Polar (H/V)	Frequency	Meter Reading	Pre-ampl ifier	Cable Loss	Antenna Factor	Emission Level	Limits	Margin	Detect or Type
	(MHz)	(dBuV)	(dB)	(dB)	(dB)	(dBuV/m)	(dBuV/ m)	(dB)	
Middle Channel:2437MHz									
V	4874	57.66	30.55	5.77	24.66	57.54	74	-16.46	PK
V	4874	40.80	30.55	5.77	24.66	40.68	54	-13.32	AV
V	7311	53.03	30.33	6.32	24.55	53.57	74	-20.43	PK
V	7311	43.51	30.33	6.32	24.55	44.05	54	-9.95	AV
V	9748	54.30	30.85	7.45	24.69	55.59	74	-18.41	PK
V	9748	41.02	30.85	7.45	24.69	42.31	54	-11.69	AV
H	4874	57.14	30.55	5.77	24.66	57.02	74	-16.98	PK
H	4874	42.63	30.55	5.77	24.66	42.51	54	-11.49	AV
H	7311	54.56	30.33	6.32	24.55	55.10	74	-18.90	PK
H	7311	40.55	30.33	6.32	24.55	41.09	54	-12.91	AV
H	9748	54.81	30.85	7.45	24.69	56.10	74	-17.90	PK
H	9748	42.84	30.85	7.45	24.69	44.13	54	-9.87	AV

Polar (H/V)	Frequency	Meter Reading	Pre-ampl ifier	Cable Loss	Antenna Factor	Emission Level	Limits	Margin	Detect or Type
	(MHz)	(dBuV)	(dB)	(dB)	(dB)	(dBuV/m)	(dBuV/ m)	(dB)	
High Channel:2462MHz									
V	4924	56.29	30.55	5.77	24.66	56.17	74	-17.83	PK
V	4924	40.51	30.55	5.77	24.66	40.39	54	-13.61	AV
V	7386	54.31	30.33	6.32	24.55	54.85	74	-19.15	PK
V	7386	44.54	30.33	6.32	24.55	45.08	54	-8.92	AV
V	9848	55.44	30.85	7.45	24.69	56.73	74	-17.27	PK
V	9848	41.71	30.85	7.45	24.69	43.00	54	-11.00	AV
H	4924	57.23	30.55	5.77	24.66	57.11	74	-16.89	PK
H	4924	43.50	30.55	5.77	24.66	43.38	54	-10.62	AV
H	7386	53.24	30.33	6.32	24.55	53.78	74	-20.22	PK
H	7386	42.02	30.33	6.32	24.55	42.56	54	-11.44	AV
H	9848	52.87	30.85	7.45	24.69	54.16	74	-19.84	PK
H	9848	41.00	30.85	7.45	24.69	42.29	54	-11.71	AV

Remark:

1. Emission Level = Meter Reading + Antenna Factor + Cable Loss – Pre-amplifier,
Margin= Emission Level - Limit
2. If peak below the average limit, the average emission was no test.
3. The amplitude of spurious emissions which are attenuated by more than 20dB below the permissible value has no need to be reported.

802.11n40

Polar (H/V)	Frequency	Meter Reading	Pre-ampl ifier	Cable Loss	Antenna Factor	Emission Level	Limits	Margin	Detect or Type
	(MHz)	(dBuV)	(dB)	(dB)	(dB)	(dBuV/m)	(dBuV/ m)	(dB)	
Low Channel:2422MHz									
V	4844	56.38	30.55	5.77	24.66	56.26	74	-17.74	PK
V	4844	42.61	30.55	5.77	24.66	42.49	54	-11.51	AV
V	7266	53.02	30.33	6.32	24.55	53.56	74	-20.44	PK
V	7266	43.71	30.33	6.32	24.55	44.25	54	-9.75	AV
V	9688	52.83	30.85	7.45	24.69	54.12	74	-19.88	PK
V	9688	42.40	30.85	7.45	24.69	43.69	54	-10.31	AV
H	4844	54.96	30.55	5.77	24.66	54.84	74	-19.16	PK
H	4844	42.00	30.55	5.77	24.66	41.88	54	-12.12	AV
H	7266	53.44	30.33	6.32	24.55	53.98	74	-20.02	PK
H	7266	41.88	30.33	6.32	24.55	42.42	54	-11.58	AV
H	9688	54.78	30.85	7.45	24.69	56.07	74	-17.93	PK
H	9688	40.40	30.85	7.45	24.69	41.69	54	-12.31	AV

Polar (H/V)	Frequency	Meter Reading	Pre-ampl ifier	Cable Loss	Antenna Factor	Emission Level	Limits	Margin	Detect or Type
	(MHz)	(dBuV)	(dB)	(dB)	(dB)	(dBuV/m)	(dBuV/ m)	(dB)	
Middle Channel:2437MHz									
V	4874	56.73	30.55	5.77	24.66	56.61	74	-17.39	PK
V	4874	41.79	30.55	5.77	24.66	41.67	54	-12.33	AV
V	7311	54.05	30.33	6.32	24.55	54.59	74	-19.41	PK
V	7311	43.58	30.33	6.32	24.55	44.12	54	-9.88	AV
V	9748	53.94	30.85	7.45	24.69	55.23	74	-18.77	PK
V	9748	41.74	30.85	7.45	24.69	43.03	54	-10.97	AV
H	4874	56.01	30.55	5.77	24.66	55.89	74	-18.11	PK
H	4874	41.83	30.55	5.77	24.66	41.71	54	-12.29	AV

H	7311	53.37	30.33	6.32	24.55	53.91	74	-20.09	PK
H	7311	41.30	30.33	6.32	24.55	41.84	54	-12.16	AV
H	9748	54.57	30.85	7.45	24.69	55.86	74	-18.14	PK
H	9748	41.58	30.85	7.45	24.69	42.87	54	-11.13	AV

Polar (H/V)	Frequency	Meter Reading	Pre-amplifier	Cable Loss	Antenna Factor	Emission Level	Limits	Margin	Detect or Type
	(MHz)	(dBuV)	(dB)	(dB)	(dB)	(dBuV/m)	(dBuV/m)	(dB)	
High Channel:2452MHz									
V	4904	57.39	30.55	5.77	24.66	57.27	74	-16.73	PK
V	4904	40.35	30.55	5.77	24.66	40.23	54	-13.77	AV
V	7356	54.35	30.33	6.32	24.55	54.89	74	-19.11	PK
V	7356	42.05	30.33	6.32	24.55	42.59	54	-11.41	AV
V	9808	53.14	30.85	7.45	24.69	54.43	74	-19.57	PK
V	9808	42.64	30.85	7.45	24.69	43.93	54	-10.07	AV
H	4904	54.29	30.55	5.77	24.66	54.17	74	-19.83	PK
H	4904	43.53	30.55	5.77	24.66	43.41	54	-10.59	AV
H	7356	52.81	30.33	6.32	24.55	53.35	74	-20.65	PK
H	7356	42.22	30.33	6.32	24.55	42.76	54	-11.24	AV
H	9808	54.97	30.85	7.45	24.69	56.26	74	-17.74	PK
H	9808	40.45	30.85	7.45	24.69	41.74	54	-12.26	AV

Remark:

1. Emission Level = Meter Reading + Antenna Factor + Cable Loss – Pre-amplifier,
Margin= Emission Level - Limit
2. If peak below the average limit, the average emission was no test.
3. The amplitude of spurious emissions which are attenuated by more than 20dB below the permissible value has no need to be reported.

5. RADIATED BAND EMISSION MEASUREMENT

5.1 TEST REQUIREMENT:

Test Requirement:	FCC Part 15 C Section 15.209 and 15.205				
Test Method:	ANSI C63.10: 2013				
Test Frequency Range:	All of the restrict bands were tested, only the worst band's (2310MHz to 2500MHz) data was showed.				
Test site:	Measurement Distance: 3m				
Receiver setup:	Frequency	Detector	RBW	VBW	Value
	Above 1GHz	Peak	1MHz	3MHz	Peak
		Average	1MHz	3MHz	Average

LIMITS OF RADIATED EMISSION MEASUREMENT (Above 1000MHz)

FREQUENCY (MHz)	Class B (dBuV/m) (at 3M)	
	PEAK	AVERAGE
Above 1000	74	54

Notes:

- (1) The limit for radiated test was performed according to FCC PART 15C.
- (2) The tighter limit applies at the band edges.
- (3) Emission level (dBuV/m) = 20log Emission level (uV/m).

5.2 TEST PROCEDURE

Above 1GHz test procedure as below:

- a. 1. The EUT was placed on the top of a rotating table 1.5 meters above the ground at a 3 meter camber. The table was rotated 360 degrees to determine the position of the highest radiation.
- b. The EUT was set 3 meters away from the interference-receiving antenna, which was mounted on the top of a variable-height antenna tower.
- c. The antenna height is varied from one meter to four meters above the ground to determine the maximum value of the field strength. Both horizontal and vertical polarizations of the antenna are set to make the measurement.
- d. For each suspected emission, the EUT was arranged to its worst case and then the antenna was tuned to heights from 1 meter to 4 meters and the rota table was turned from 0 degrees to 360 degrees to find the maximum reading.
- e. The test-receiver system was set to Peak Detect Function and Specified Bandwidth with Maximum Hold Mode.

f. If the emission level of the EUT in peak mode was 10dB lower than the limit specified, then testing could be stopped and the peak values of the EUT would be reported. Otherwise the emissions that did not have 10dB margin would be re-tested one by one using peak, quasi-peak or average method as specified and then reported in a data sheet.

g. Test the EUT in the lowest channel, the Highest channel

Note:

Both horizontal and vertical antenna polarities were tested

and performed pretest to three orthogonal axis. The worst case emissions were reported

5.3 DEVIATION FROM TEST STANDARD

No deviation

5.4 TEST SETUP

Radiated Emission Test-Up Frequency Above 1GHz

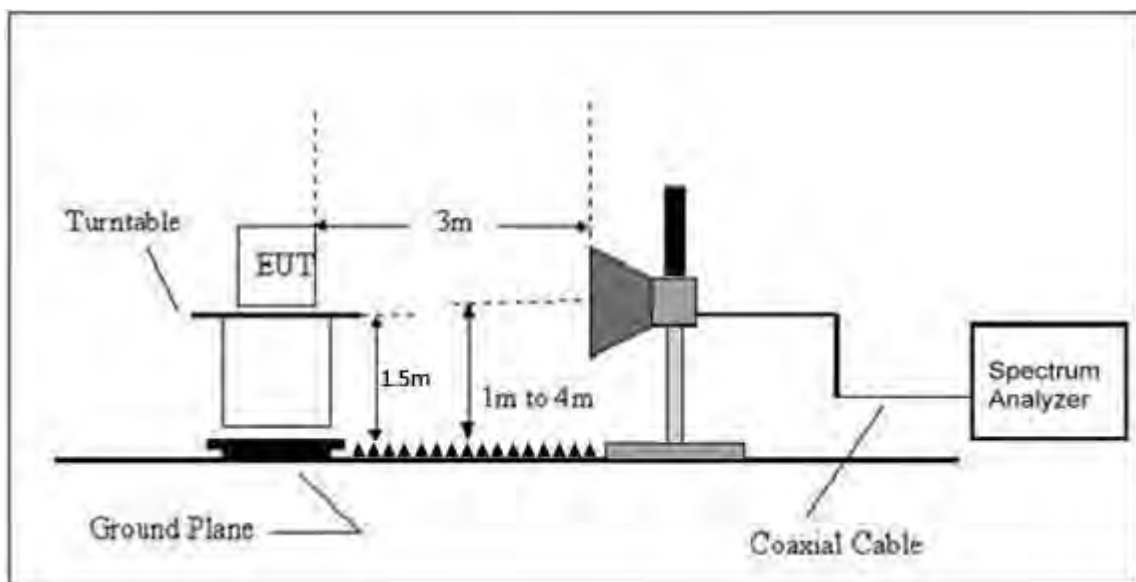

5.5 EUT OPERATING CONDITIONS

The EUT tested system was configured as the statements of 2.3 Unless otherwise a special operating condition is specified in the follows during the testing.

5.6 TEST RESULT

	Polar (H/V)	Frequency (MHz)	Meter Reading (dBuV)	Pre-amplifier (dB)	Cable Loss (dB)	Antenna Factor (dB/m)	Emission level (dBuV/m)	Limit (dBuV/m)	Detector Type	Result
802.11b	Low Channel 2412MHz									
	H	2390.00	60.29	30.22	4.85	23.98	58.90	74	PK	PASS
	H	2390.00	45.42	30.22	4.85	23.98	44.03	54	AV	PASS
	H	2400.00	61.33	30.22	4.85	23.98	59.94	74	PK	PASS
	H	2400.00	43.26	30.22	4.85	23.98	41.87	54	AV	PASS
	V	2390.00	61.82	30.22	4.85	23.98	60.43	74	PK	PASS
	V	2390.00	45.35	30.22	4.85	23.98	43.96	54	AV	PASS
	V	2400.00	57.49	30.22	4.85	23.98	56.10	74	PK	PASS
	V	2400.00	44.56	30.22	4.85	23.98	43.17	54	AV	PASS
	High Channel 2462MHz									
	H	2483.50	60.97	30.22	4.85	23.98	59.58	74	PK	PASS
	H	2485.50	45.13	30.22	4.85	23.98	43.74	54	AV	PASS
	H	2483.50	64.64	30.22	4.85	23.98	63.25	74	PK	PASS
	H	2485.50	49.15	30.22	4.85	23.98	47.76	54	AV	PASS
	V	2483.50	60.68	30.22	4.85	23.98	59.29	74	PK	PASS
	V	2485.50	42.90	30.22	4.85	23.98	41.51	54	AV	PASS
	V	2483.50	60.49	30.22	4.85	23.98	59.10	74	PK	PASS
	V	2485.50	43.52	30.22	4.85	23.98	42.13	54	AV	PASS
802.11g	Low Channel 2412MHz									
	H	2390.00	58.09	30.22	4.85	23.98	56.70	74	PK	PASS
	H	2390.00	45.67	30.22	4.85	23.98	44.28	54	AV	PASS
	H	2400.00	62.30	30.22	4.85	23.98	60.91	74	PK	PASS
	H	2400.00	44.79	30.22	4.85	23.98	43.40	54	AV	PASS
	V	2390.00	61.31	30.22	4.85	23.98	59.92	74	PK	PASS
	V	2390.00	41.78	30.22	4.85	23.98	40.39	54	AV	PASS
	V	2400.00	56.14	30.22	4.85	23.98	54.75	74	PK	PASS
	V	2400.00	45.63	30.22	4.85	23.98	44.24	54	AV	PASS
	High Channel 2462MHz									
	H	2483.50	61.79	30.22	4.85	23.98	60.40	74	PK	PASS
	H	2485.50	49.40	30.22	4.85	23.98	48.01	54	AV	PASS
	H	2483.50	58.91	30.22	4.85	23.98	57.52	74	PK	PASS
	H	2485.50	44.64	30.22	4.85	23.98	43.25	54	AV	PASS
	V	2483.50	61.97	30.22	4.85	23.98	60.58	74	PK	PASS
	V	2485.50	43.72	30.22	4.85	23.98	42.33	54	AV	PASS
	V	2483.50	65.74	30.22	4.85	23.98	64.35	74	PK	PASS

	V	2485.50	47.87	30.22	4.85	23.98	46.48	54	AV	PASS
--	---	---------	-------	-------	------	-------	-------	----	----	------

802.11n20	Low Channel 2412MHz									
	H	2390.00	60.61	30.22	4.85	23.98	59.22	74	PK	PASS
	H	2390.00	42.78	30.22	4.85	23.98	41.39	54	AV	PASS
	H	2400.00	61.12	30.22	4.85	23.98	59.73	74	PK	PASS
	H	2400.00	45.04	30.22	4.85	23.98	43.65	54	AV	PASS
	V	2390.00	61.85	30.22	4.85	23.98	60.46	74	PK	PASS
	V	2390.00	42.36	30.22	4.85	23.98	40.97	54	AV	PASS
	V	2400.00	58.16	30.22	4.85	23.98	56.77	74	PK	PASS
	V	2400.00	43.23	30.22	4.85	23.98	41.84	54	AV	PASS
	High Channel 2462MHz									
	H	2483.50	62.43	30.22	4.85	23.98	61.04	74	PK	PASS
	H	2485.50	44.53	30.22	4.85	23.98	43.14	54	AV	PASS
	H	2483.50	59.79	30.22	4.85	23.98	58.40	74	PK	PASS
	H	2485.50	48.50	30.22	4.85	23.98	47.11	54	AV	PASS
	V	2483.50	62.49	30.22	4.85	23.98	61.10	74	PK	PASS
	V	2485.50	45.67	30.22	4.85	23.98	44.28	54	AV	PASS
V	2483.50	65.24	30.22	4.85	23.98	63.85	74	PK	PASS	
V	2485.50	45.42	30.22	4.85	23.98	44.03	54	AV	PASS	

Remark:

1. Emission Level = Meter Reading + Antenna Factor + Cable Loss – Pre-amplifier, Margin= Emission Level - Limit

802.11n40	Low Channel 2422MHz									
	H	2390.00	61.61	30.22	4.85	23.98	60.22	74	PK	PASS
	H	2390.00	44.94	30.22	4.85	23.98	43.55	54	AV	PASS
	H	2400.00	60.82	30.22	4.85	23.98	59.43	74	PK	PASS
	H	2400.00	44.18	30.22	4.85	23.98	42.79	54	AV	PASS
	V	2390.00	61.56	30.22	4.85	23.98	60.17	74	PK	PASS
	V	2390.00	44.07	30.22	4.85	23.98	42.68	54	AV	PASS
	V	2400.00	55.39	30.22	4.85	23.98	54.00	74	PK	PASS
	V	2400.00	44.92	30.22	4.85	23.98	43.53	54	AV	PASS
	High Channel 2452MHz									
	H	2483.50	61.61	30.22	4.85	23.98	60.22	74	PK	PASS
	H	2485.50	46.23	30.22	4.85	23.98	44.84	54	AV	PASS
	H	2483.50	64.66	30.22	4.85	23.98	63.27	74	PK	PASS

	H	2485.50	47.93	30.22	4.85	23.98	46.54	54	AV	PASS
	V	2483.50	65.73	30.22	4.85	23.98	64.34	74	PK	PASS
	V	2485.50	46.94	30.22	4.85	23.98	45.55	54	AV	PASS
	V	2483.50	60.84	30.22	4.85	23.98	59.45	74	PK	PASS
	V	2485.50	43.59	30.22	4.85	23.98	42.20	54	AV	PASS

Remark:

1. Emission Level = Meter Reading + Antenna Factor + Cable Loss – Pre-amplifier, Margin= Emission Level - Limit

6.POWER SPECTRAL DENSITY TEST

Test Requirement:	FCC Part15 C Section 15.247 (e)
Test Method:	KDB558074 D0115.247 Meas Guidance v 05r02

6.1 APPLIED PROCEDURES / LIMIT

FCC Part15 (15.247) , Subpart C				
Section	Test Item	Limit	Frequency Range (MHz)	Result
15.247	Power Spectral Density	8dBm/3kHz	2400-2483.5	PASS

6.2 TEST PROCEDURE

1. Set analyzer center frequency to DTS channel center frequency.
2. Set the span to 1.5 times the DTS bandwidth.
3. Set the RBW to: $3\text{ kHz} \leq \text{RBW} \leq 100\text{ kHz}$.
4. Set the VBW $\geq 3 \times \text{RBW}$.
5. Detector = peak.
6. Sweep time = auto couple.
7. Trace mode = max hold.
8. Allow trace to fully stabilize.
9. Use the peak marker function to determine the maximum amplitude level within the RBW.
10. If measured value exceeds limit, reduce RBW (no less than 3 kHz) and repeat.

6.3 DEVIATION FROM STANDARD

No deviation.

6.4 TEST SETUP



6.5 EUT OPERATION CONDITIONS

The EUT tested system was configured as the statements of 2.1 Unless otherwise a special operating condition is specified in the follows during the testing.

6.6 TEST RESULT

Temperature :	26°C	Relative Humidity :	54%
Pressure :	101kPa	Test Voltage :	DC 3.7V
Test Mode :	TX b Mode		

Frequency	Power Spectral Density (dBm/3kHz)	Limit (dBm/3kHz)	Result
2412 MHz	-18.15	8	PASS
2437 MHz	-15.992	8	PASS
2462 MHz	-15.687	8	PASS

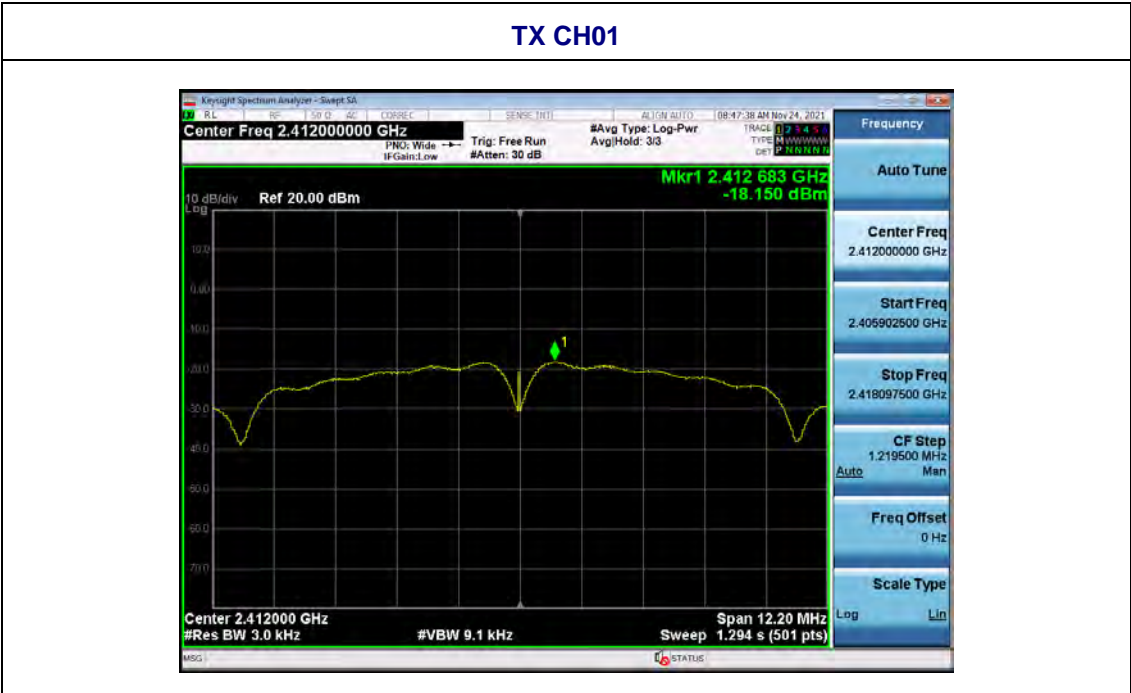

TX CH06



TX CH11



Temperature :	26°C	Relative Humidity :	54%
Pressure :	101kPa	Test Voltage :	DC 3.7V
Test Mode :	TX g Mode		

Frequency	Power Spectral Density (dBm/3kHz)	Limit (dBm/3kHz)	Result
2412 MHz	-17.166	8	PASS
2437 MHz	-14.882	8	PASS
2462 MHz	-15.124	8	PASS

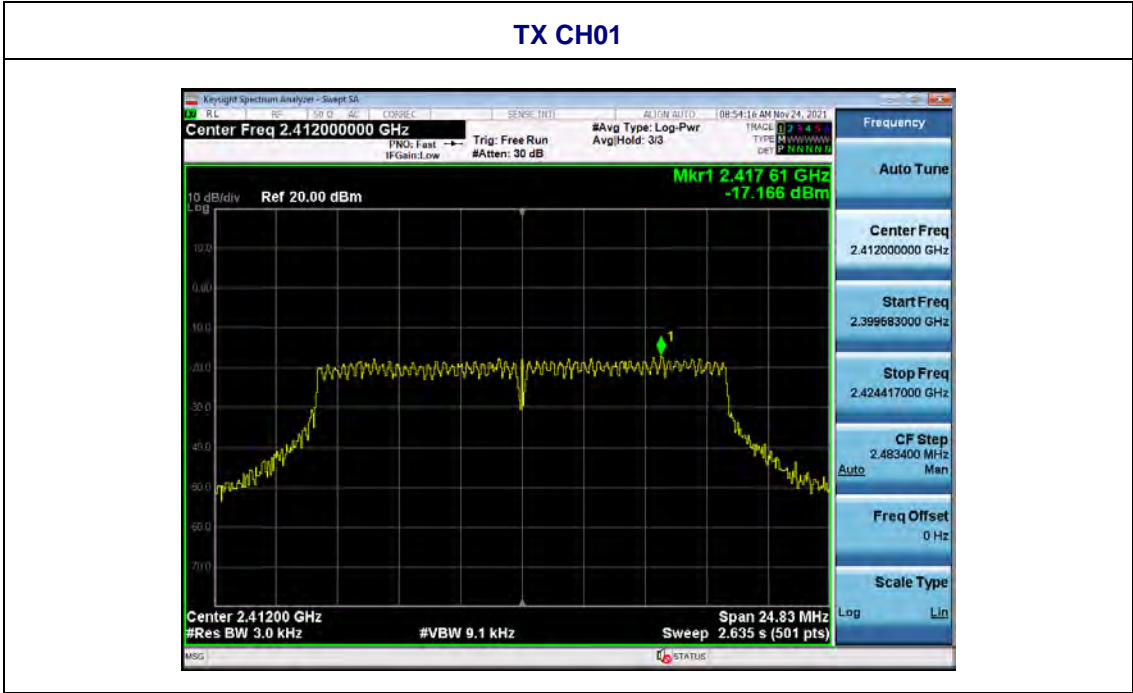

TX CH06



TX CH11



Temperature :	26°C	Relative Humidity :	54%
Pressure :	101kPa	Test Voltage :	DC3.7V
Test Mode :	TX n Mode(20M)		

Frequency	Power Spectral Density (dBm/3kHz)	Limit (dBm/3kHz)	Result
2412 MHz	-16.864	8	PASS
2437 MHz	-14.716	8	PASS
2462 MHz	-14.446	8	PASS

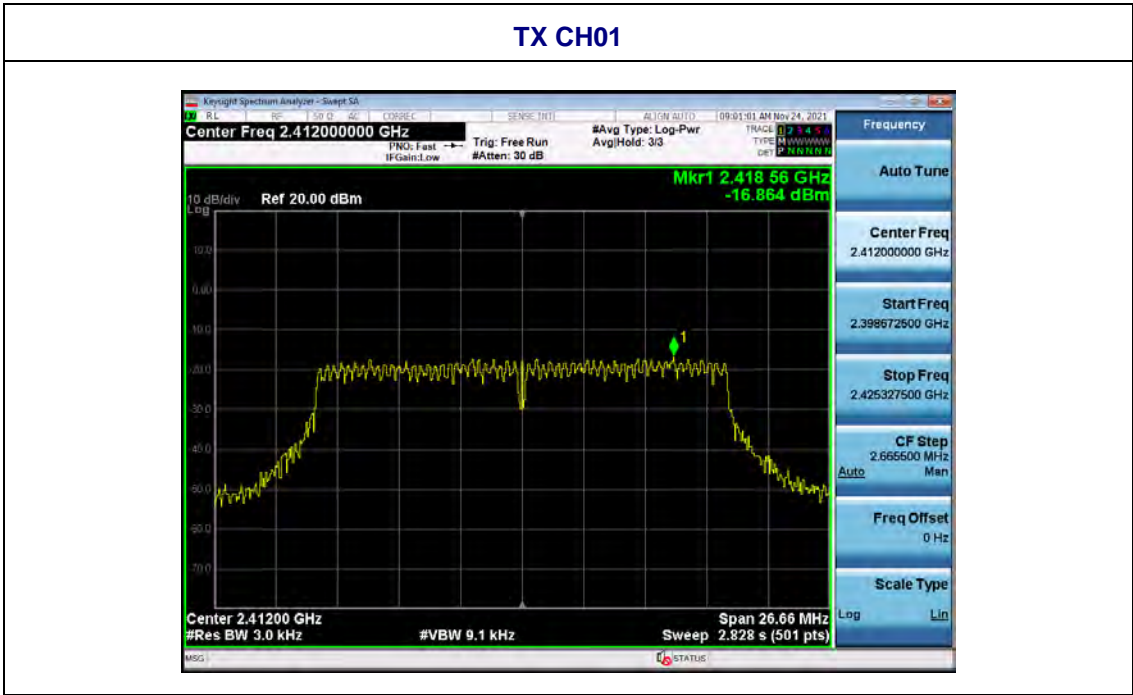

TX CH06



TX CH11



Temperature :	26°C	Relative Humidity :	54%
Pressure :	101kPa	Test Voltage :	DC3.7V
Test Mode :	TX n Mode(40M)		

Frequency	Power Spectral Density (dBm/3kHz)	Limit (dBm/3kHz)	Result
2422 MHz	-17.204	8	PASS
2437 MHz	-17.625	8	PASS
2452 MHz	-14.634	8	PASS

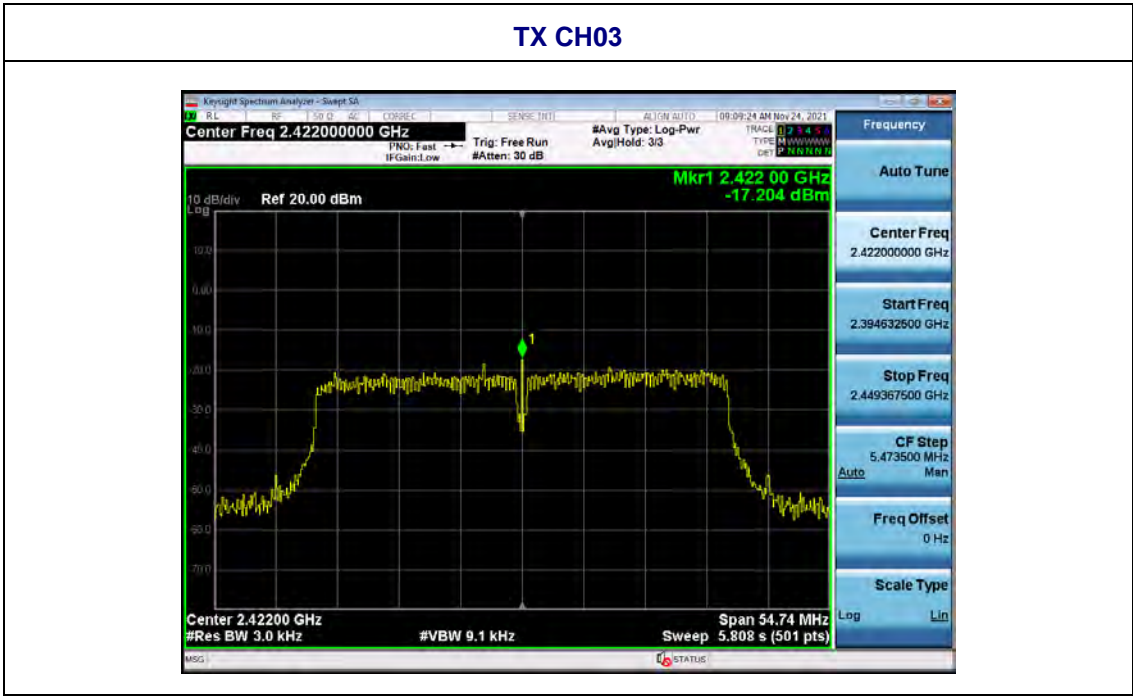

TX CH06

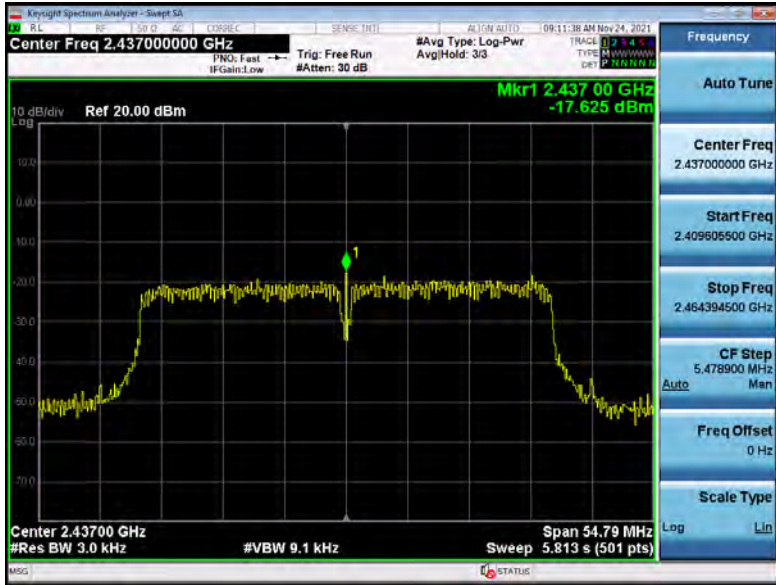

TX CH09



7. CHANNEL BANDWIDTH

Test Requirement:	FCC Part15 C Section 15.247 (a)(2)
Test Method:	KDB558074 D0115.247 Meas Guidance v05r02

7.1 APPLIED PROCEDURES / LIMIT

FCC Part15 (15.247) , Subpart C				
Section	Test Item	Limit	Frequency Range (MHz)	Result
15.247(a)(2)	Bandwidth	$\geq 500\text{KHz}$ (6dB bandwidth)	2400-2483.5	PASS

7.2 TEST PROCEDURE

1. Set RBW = 100 kHz.
2. Set the video bandwidth (VBW) $\geq 3 \times \text{RBW}$.
3. Detector = Peak.
4. Trace mode = max hold.
5. Sweep = auto couple.
6. Allow the trace to stabilize.
7. Measure the maximum width of the emission that is constrained by the frequencies associated with the two outermost amplitude points (upper and lower frequencies) that are attenuated by 6 dB relative to the maximum level measured in the fundamental emission.

7.3 DEVIATION FROM STANDARD

No deviation.

7.4 TEST SETUP



7.5 EUT OPERATION CONDITIONS

The EUT tested system was configured as the statements of 2.4 Unless otherwise a special operating condition is specified in the follows during the testing.

7.6 TEST RESULT

Temperature :	26°C	Relative Humidity :	54%
Pressure :	101kPa	Test Voltage :	DC 3.7V
Test Mode :	TX Mode		

Test CH	Channel Bandwidth (MHz)				Limit(KHz)	Result
	802.11b	802.11g	802.11n(HT20)	802.11n(HT40)		
Lowest	8.13	16.56	17.77	36.49	>500	Pass
Middle	8.593	16.57	17.75	36.53		
Highest	9.062	16.53	17.80	36.55		

Test CH	99% Occupy Bandwidth (MHz)				Result
	802.11b	802.11g	802.11n(HT20)	802.11n(HT40)	
Lowest	13.233	16.515	17.704	36.183	Pass
Middle	13.208	16.977	17.933	36.235	
Highest	13.593	16.908	17.888	36.264	

Test plot as follows:

802.11b

802.11g

Lowest channel

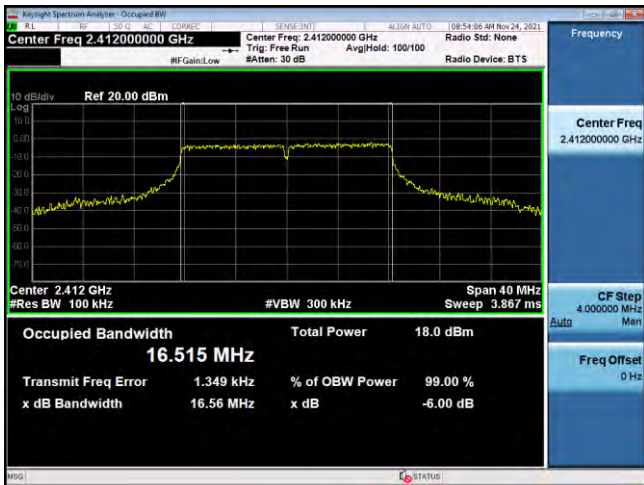
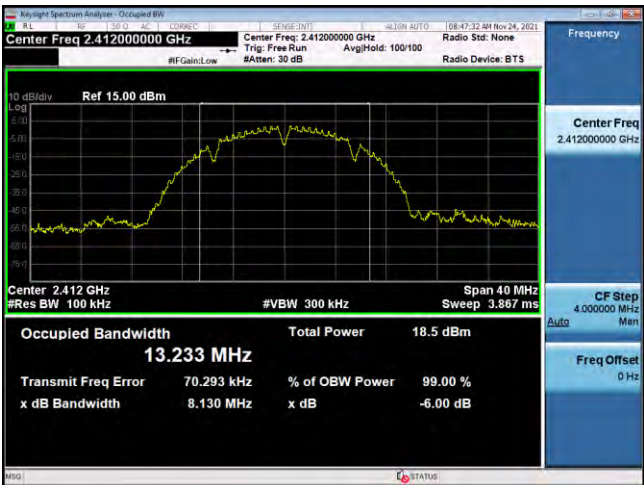

Middle channel

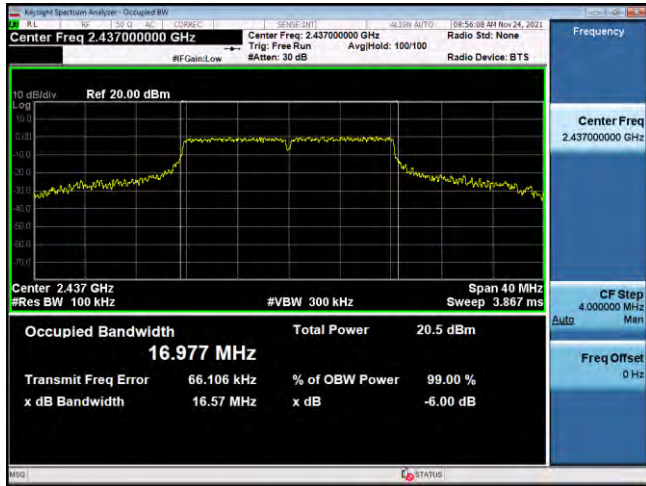

Highest channel

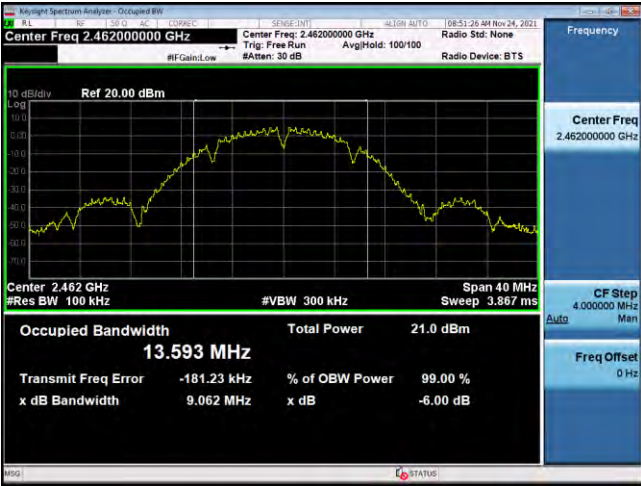

802.11n20

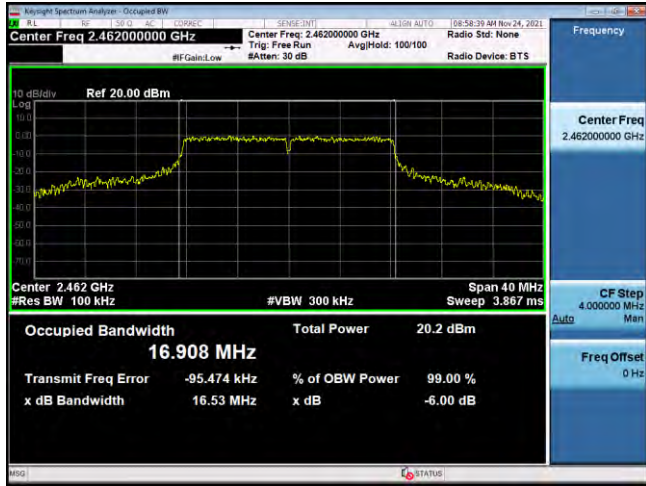

802.11n40

Lowest channel

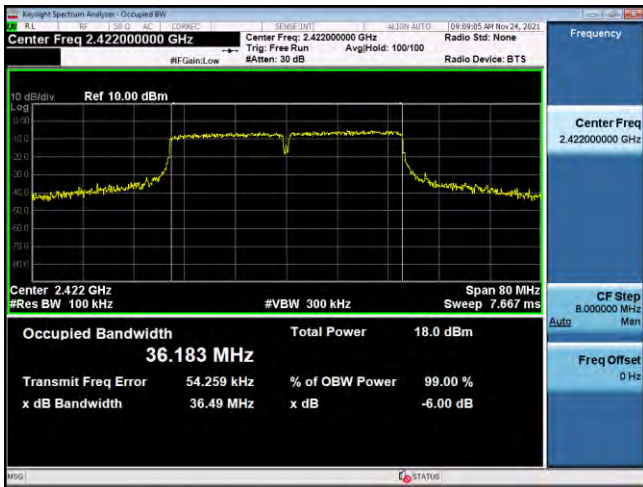
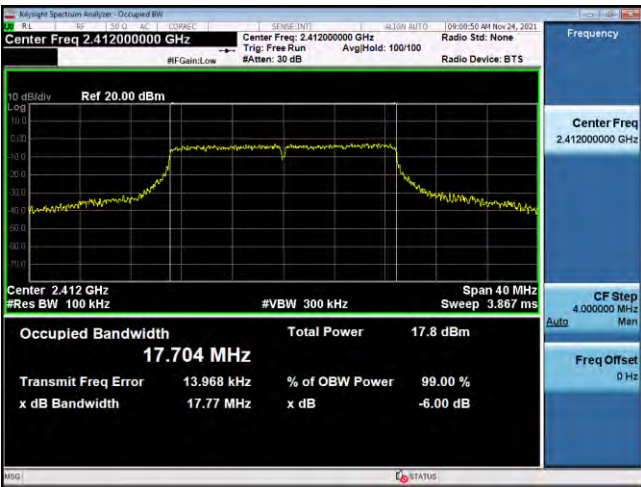

Middle channel

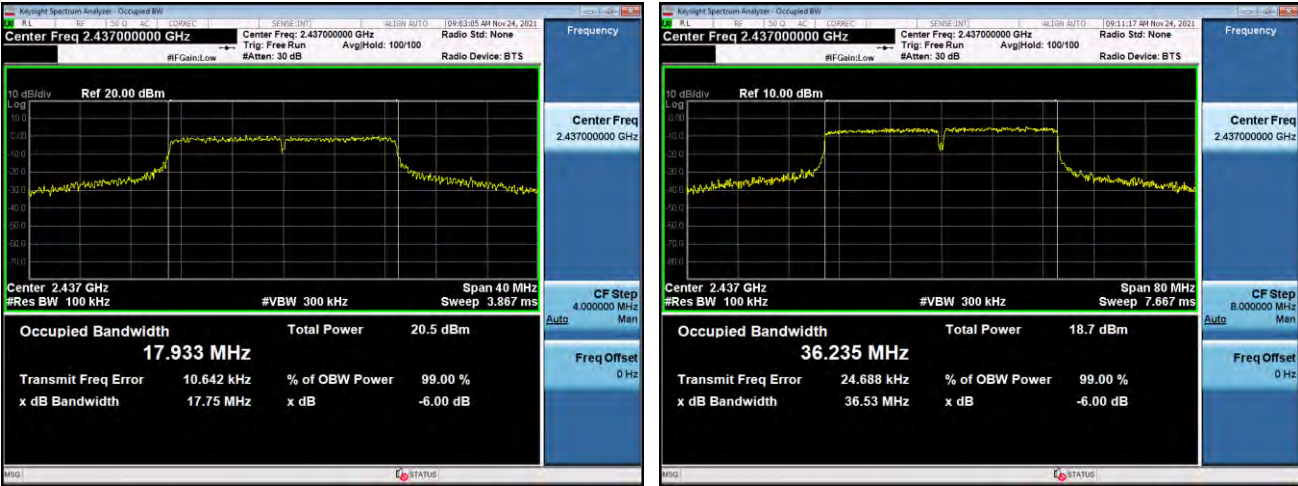

Highest channel

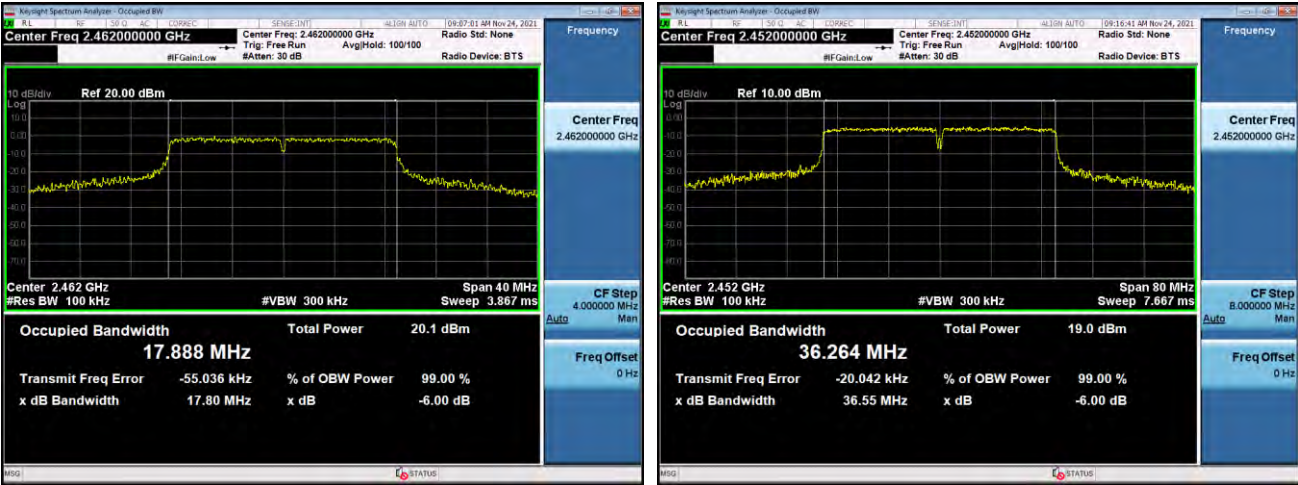

8. OUTPUT POWER TEST

Test Requirement:	FCC Part15 C Section 15.247 (b)(3)
Test Method:	KDB558074 D0115.247 Meas Guidance v05r02

8.1 APPLIED PROCEDURES/LIMIT

FCC Part15 (15.247) , Subpart C				
Section	Test Item	Limit	Frequency Range (MHz)	Result
15.247(b)(3)	Peak Output Power	1 watt or 30dBm	2400-2483.5	PASS

8.2 TEST PROCEDURE

- a. The EUT was directly connected to the Power meter

8.3 DEVIATION FROM STANDARD

No deviation.

8.4 TEST SETUP



8.5 EUT OPERATION CONDITIONS

The EUT tested system was configured as the statements of 2.4 Unless otherwise a special operating condition is specified in the follows during the testing.

8.6 TEST RESULT

Temperature :	26°C	Relative Humidity :	54%
Pressure :	101kPa	Test Voltage :	DC3.7V

Test CH	Peak Output Power (dBm)				Limit(dBm)	Result
	802.11b	802.11g	802.11n(HT20)	802.11n(HT40)		
Lowest	7.028	7.368	7.202	6.249	30.00	Pass
Middle	8.292	8.064	8.076	7.892		
Highest	8.714	7.664	7.537	6.166		

9. CONDUCTED BAND EDGE AND SPURIOUS EMISSION

Test Requirement:	FCC Part15 C Section 15.247 (d)
Test Method:	KDB558074 D0115.247 Meas Guidance v05r02

9.1 APPLICABLE STANDARD

in any 100 kHz bandwidth outside the frequency bands in which the spread spectrum intentional radiator is operating, the radio frequency power that is produced by the intentional radiator shall be at least 20dB below that in the 100kHz bandwidth within the band that contains the highest level of the desired power, In addition, radiated emissions which fall in the restricted bands, as defined in§15.205(a), must also comply with the radiated emission limits specified in15.209(a).

9.2 TEST PROCEDURE

Using the following spectrum analyzer setting:

- A) Set the RBW = 100KHz.
- B) Set the VBW = 300KHz.
- C) Sweep time = auto couple.
- D) Detector function = peak.
- E) Trace mode = max hold.
- F) Allow trace to fully stabilize.

9.3 DEVIATION FROM STANDARD

No deviation.

9.4 TEST SETUP



9.5 EUT OPERATION CONDITIONS

The EUT tested system was configured as the statements of 2.4 Unless otherwise a special operating condition is specified in the follows during the testing.

9.6 TEST RESULTS

Test plot as follows:

Test mode: 802.11b

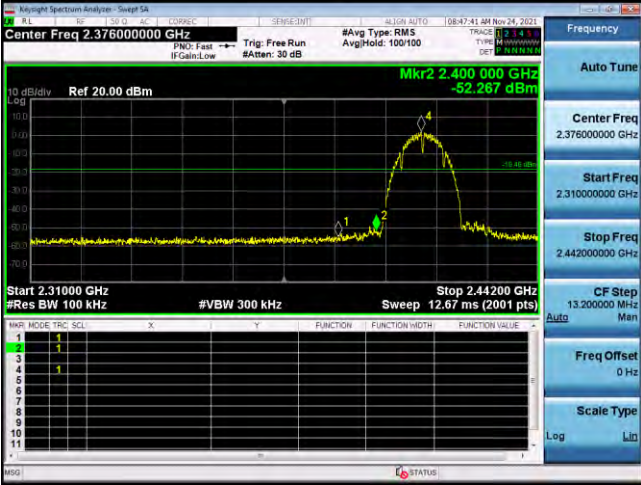

Lowest channel

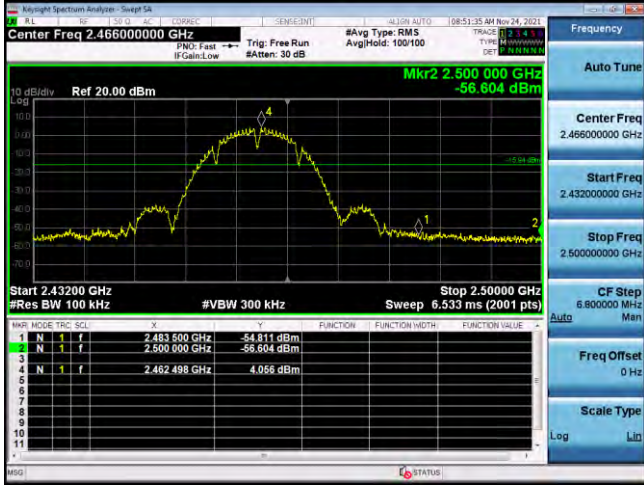

Highest channel

Test mode: 802.11g

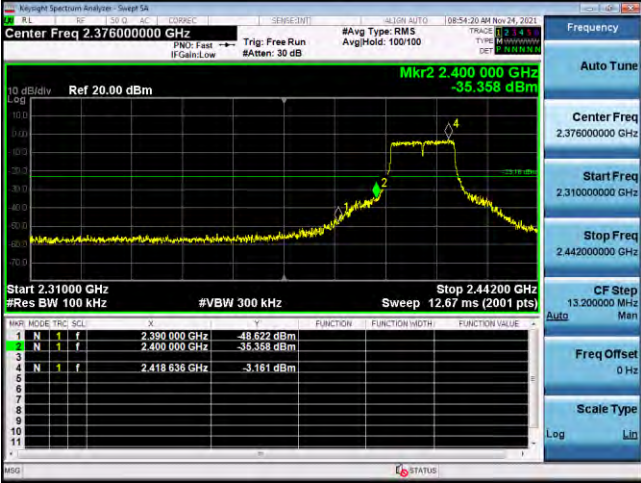

Lowest channel

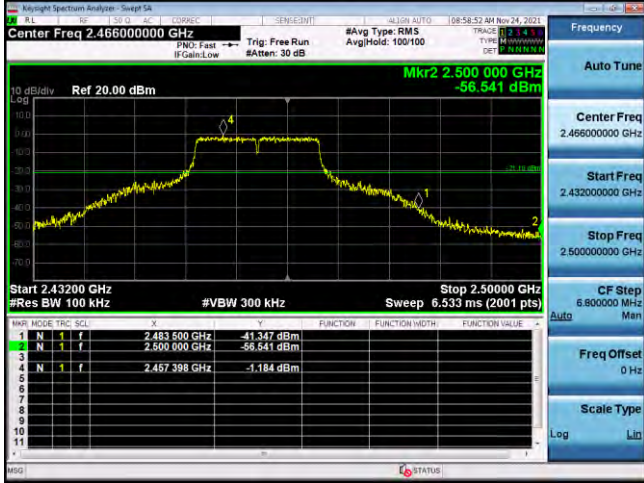

Highest channel

Test mode:

802.11n(HT20)

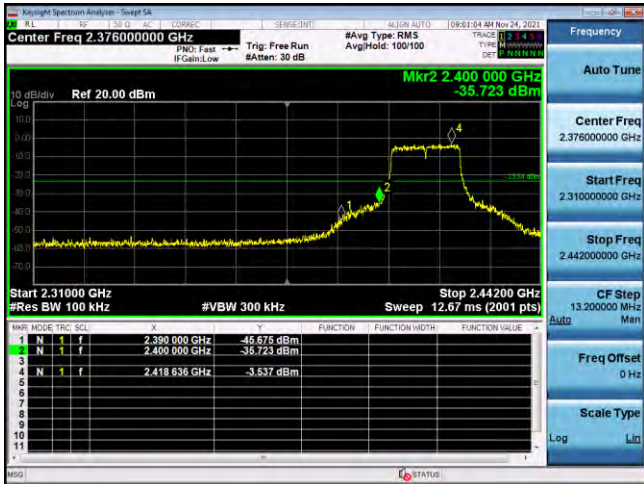

Lowest channel

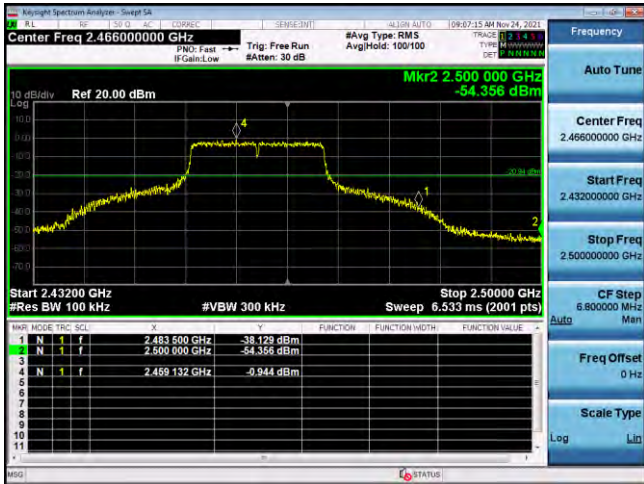

Highest channel

Test mode:

802.11n(HT40)

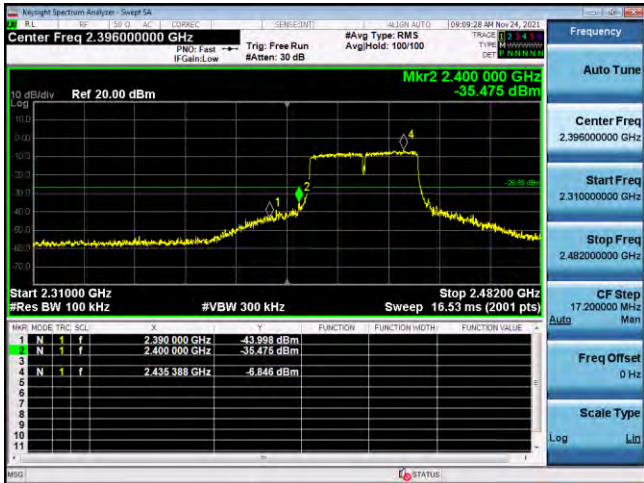

Lowest channel



Highest channel

Test plot as follows:

802.11b Lowest channel

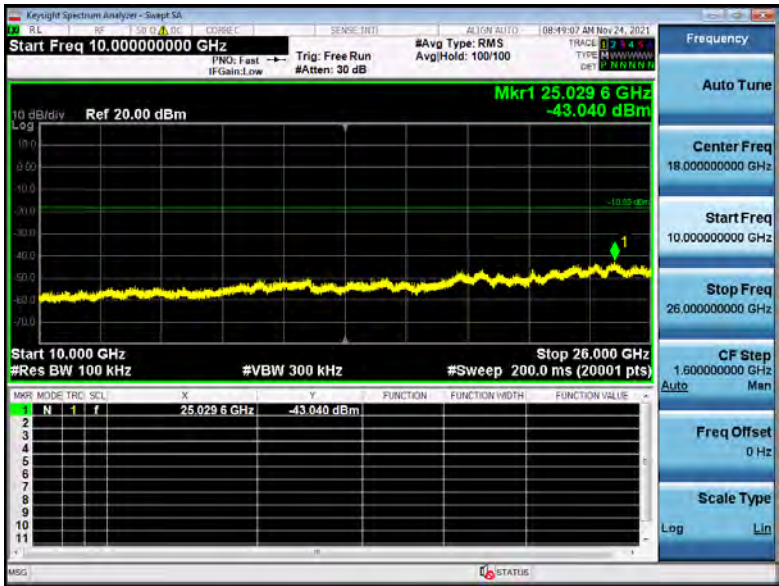
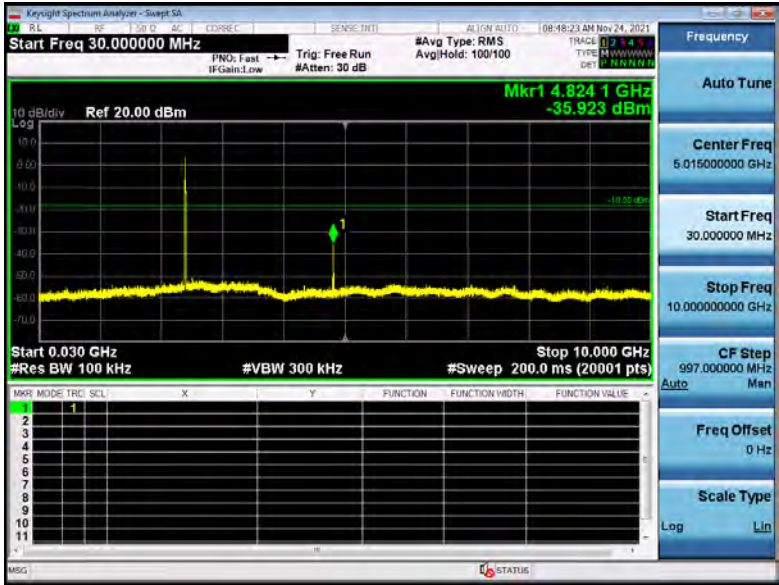
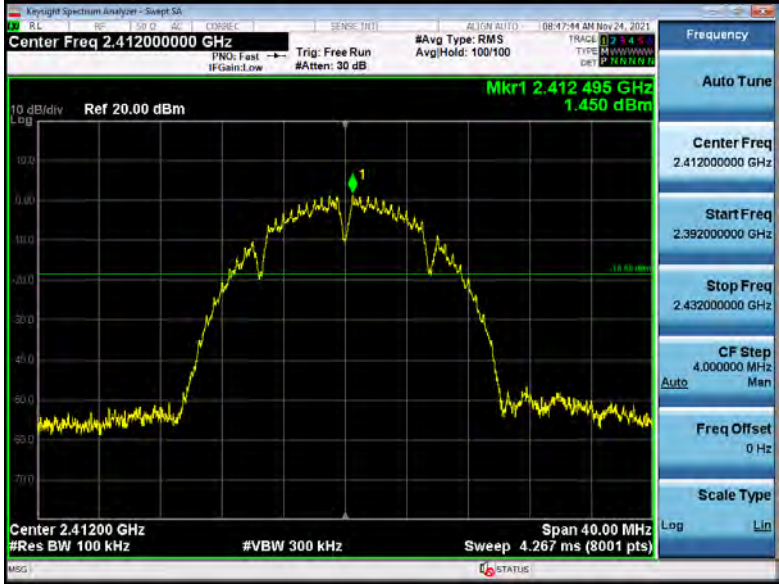

802.11b Middle channel

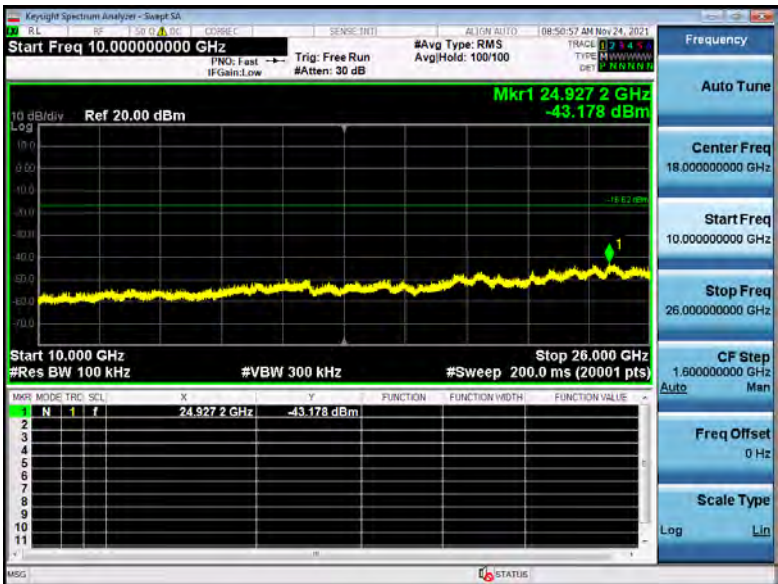
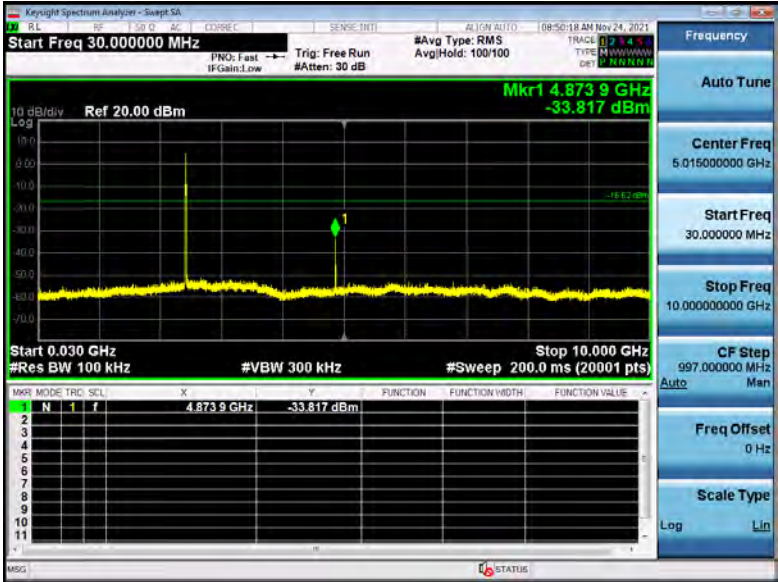
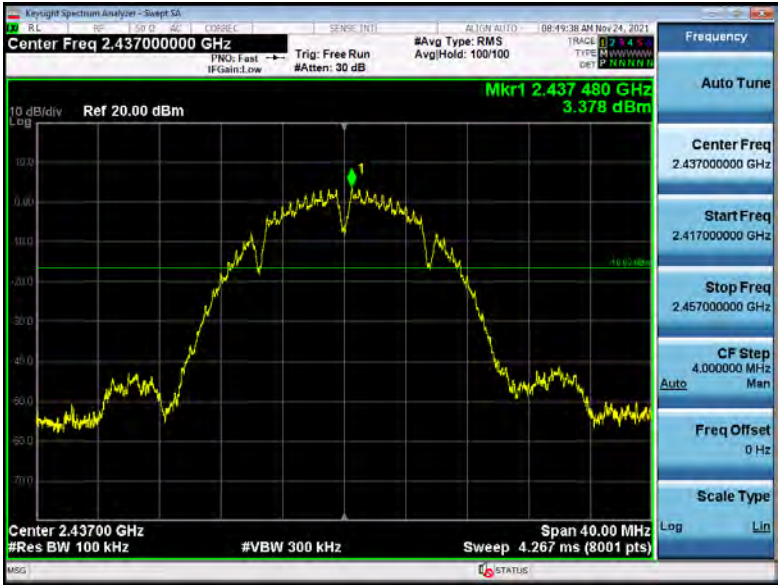

802.11b Highest channel

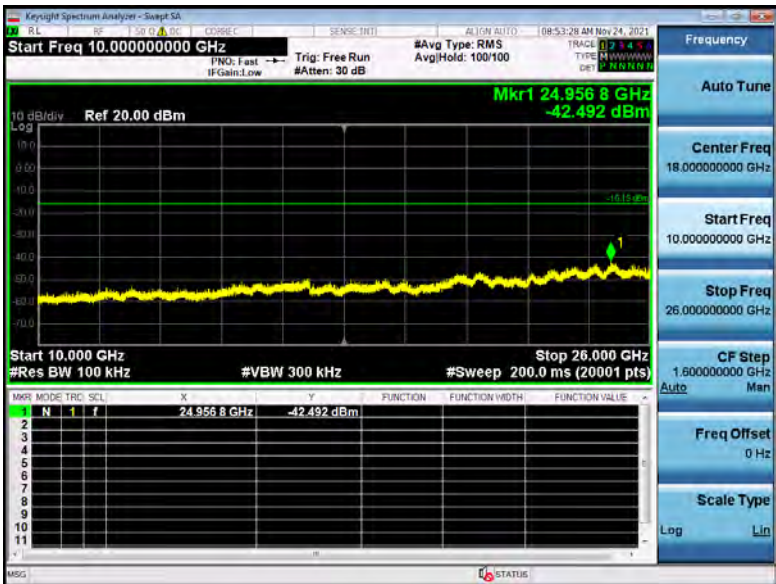
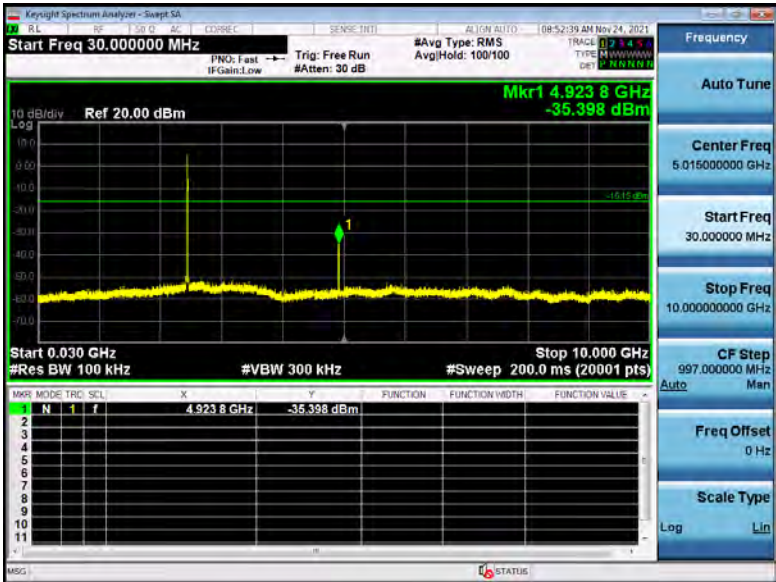

802.11g Lowest channel

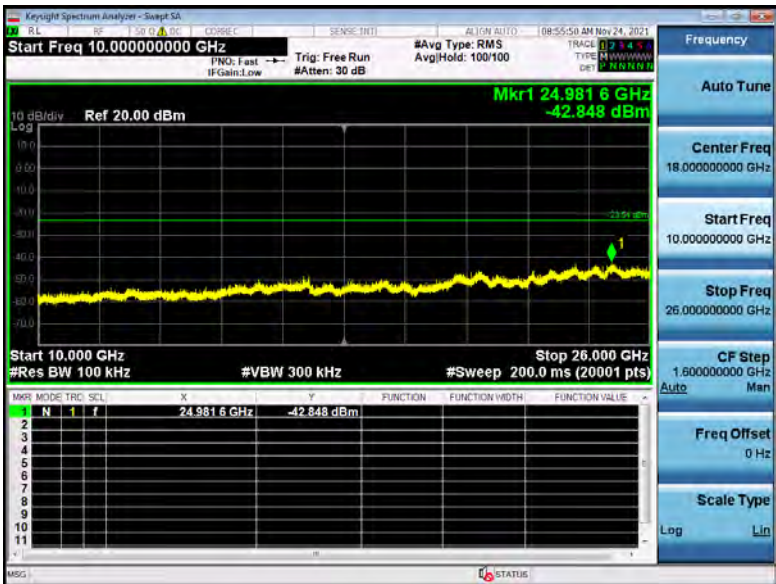
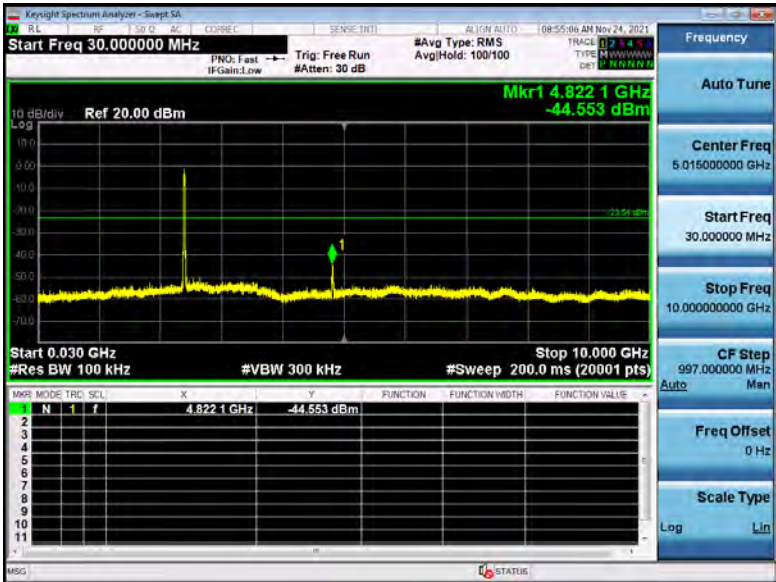
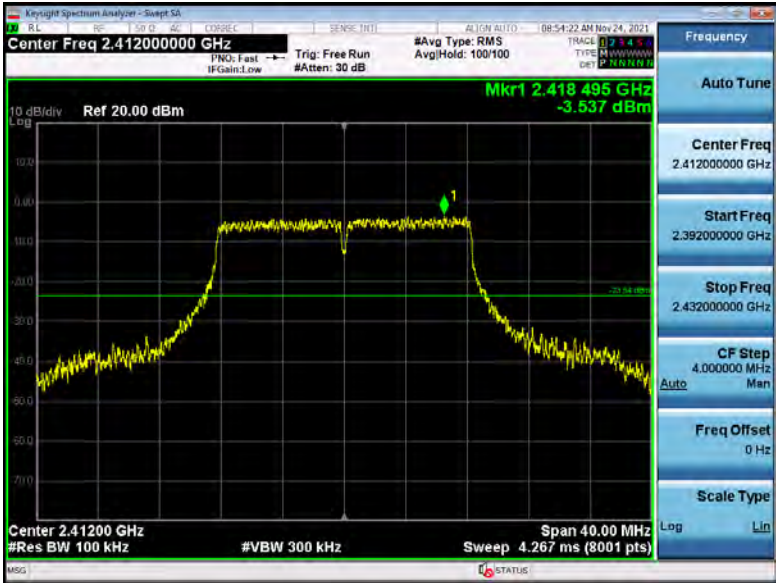

802.11g Middle channel

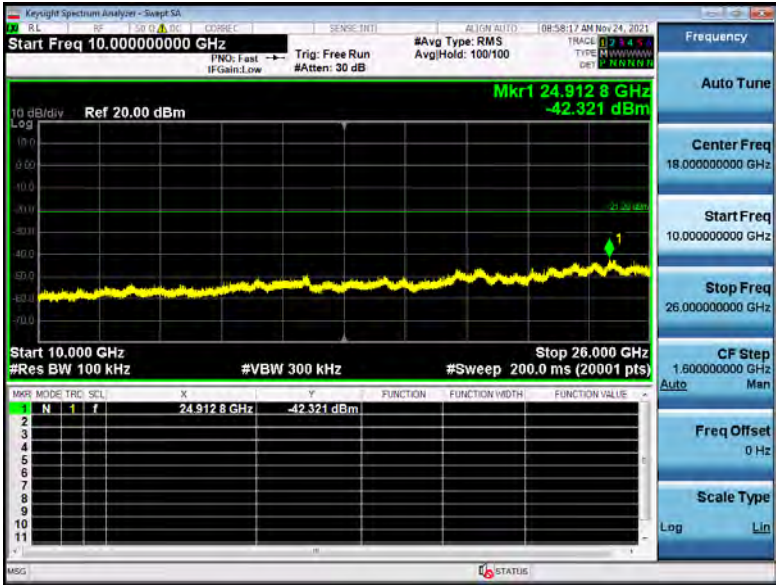
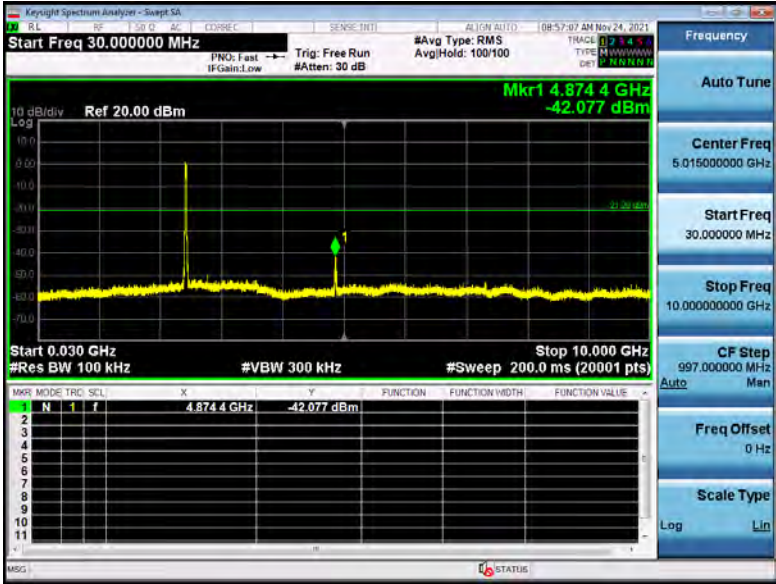
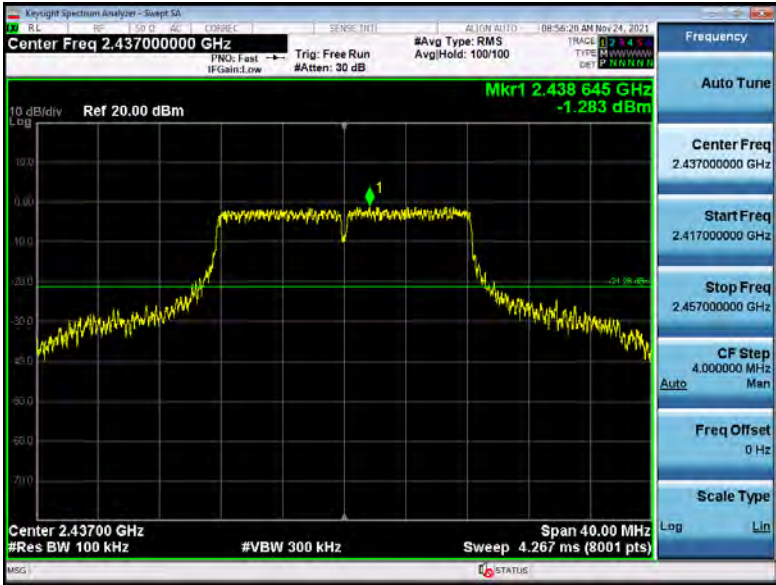

802.11g Highest channel

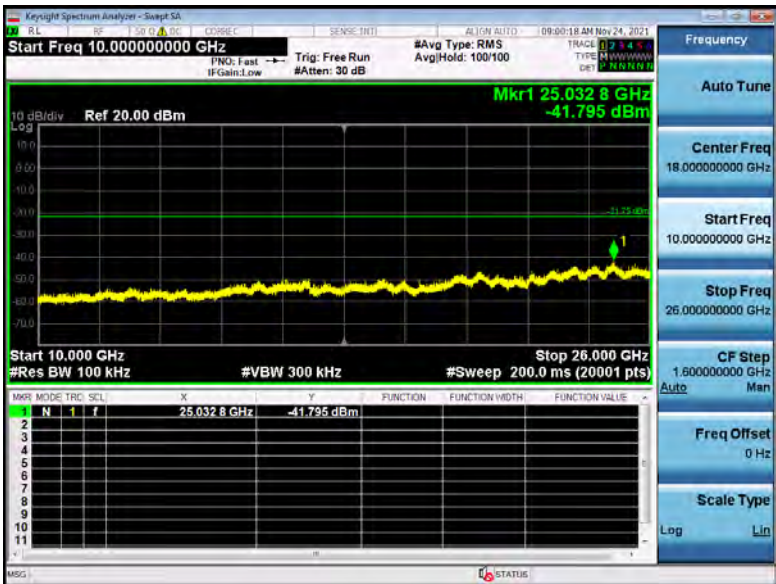
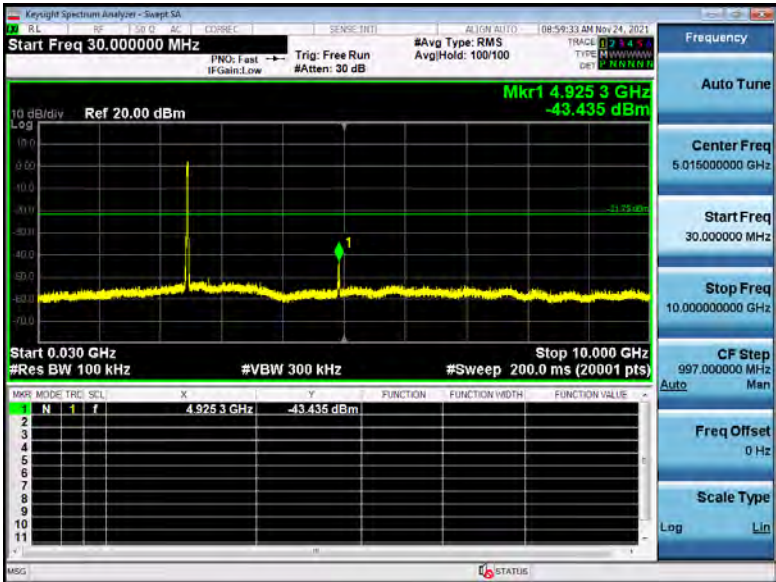
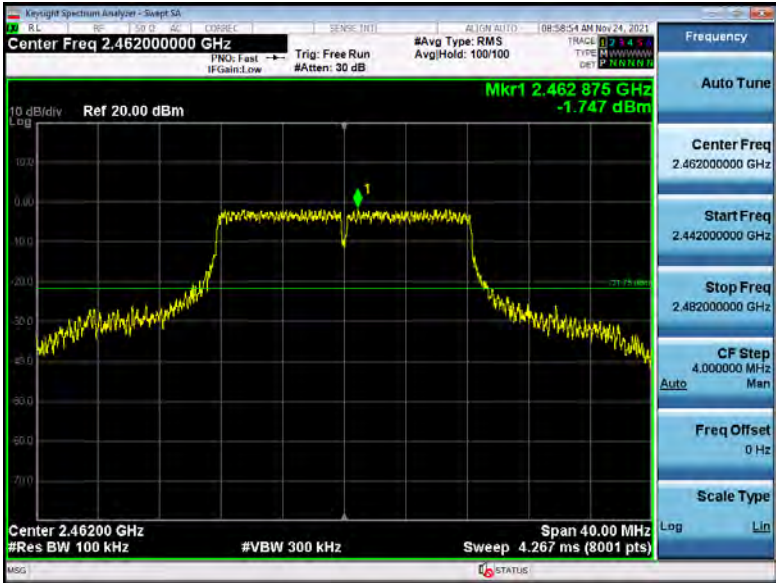

802.11n(HT20) Lowest channel

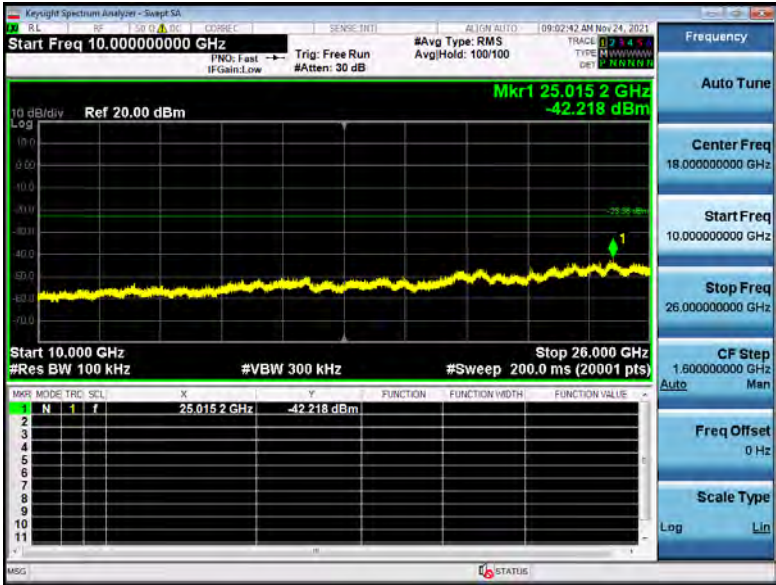
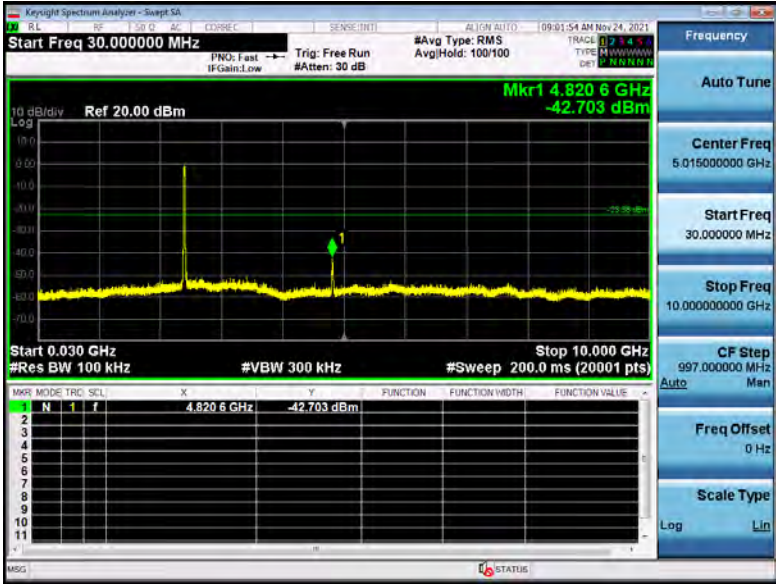
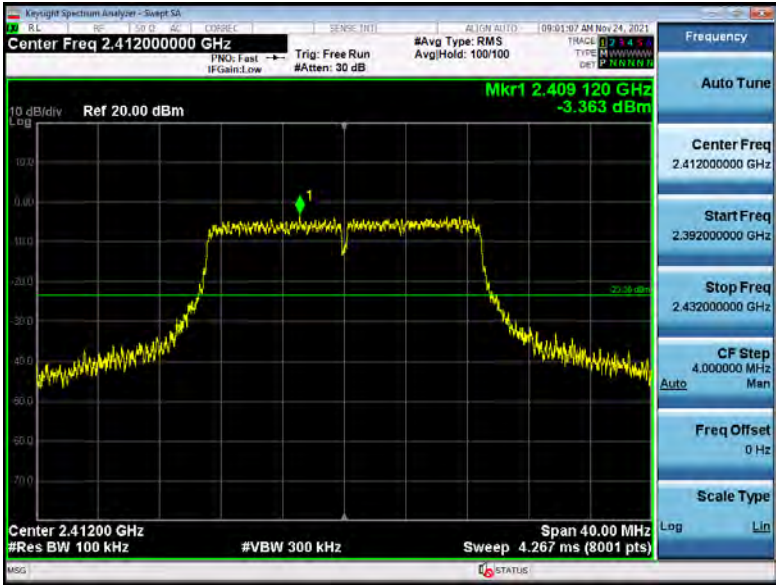

802.11n(HT20) Middle channel

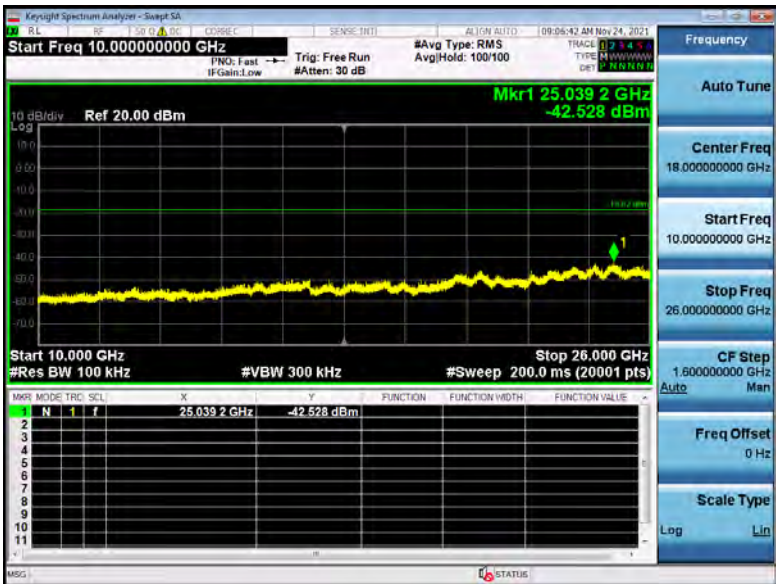
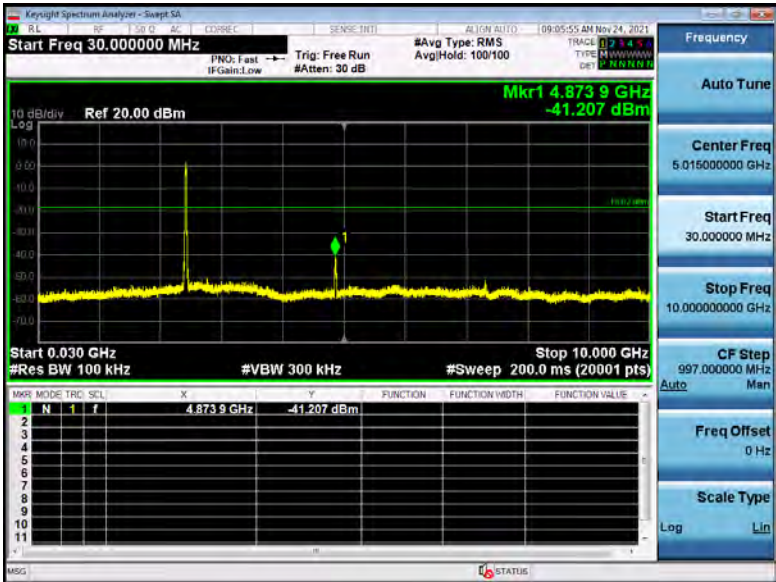

802.11n(HT20) Highest channel

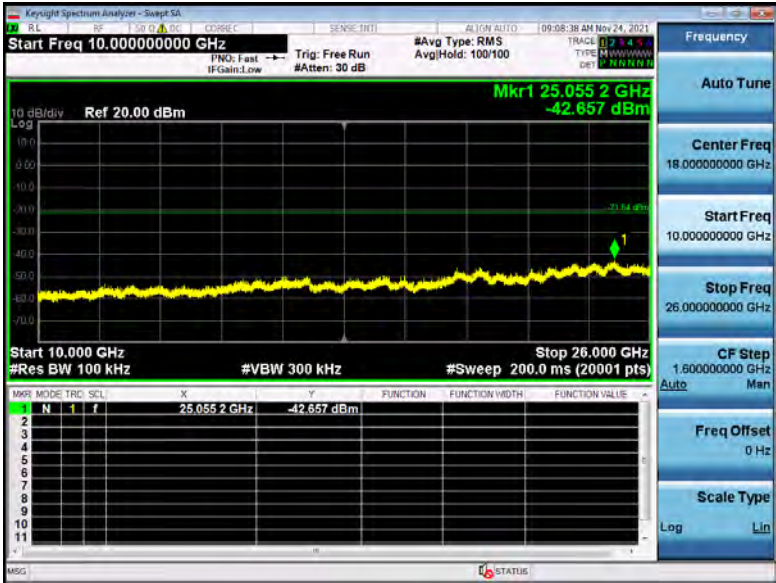
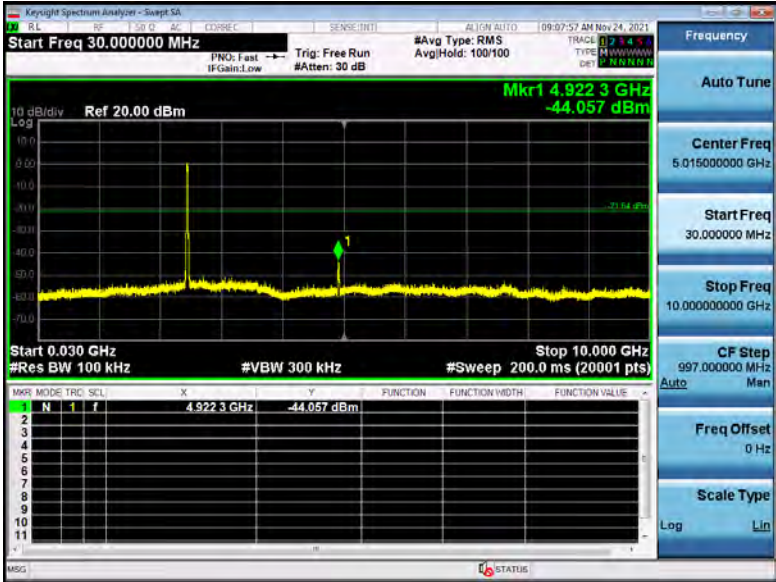
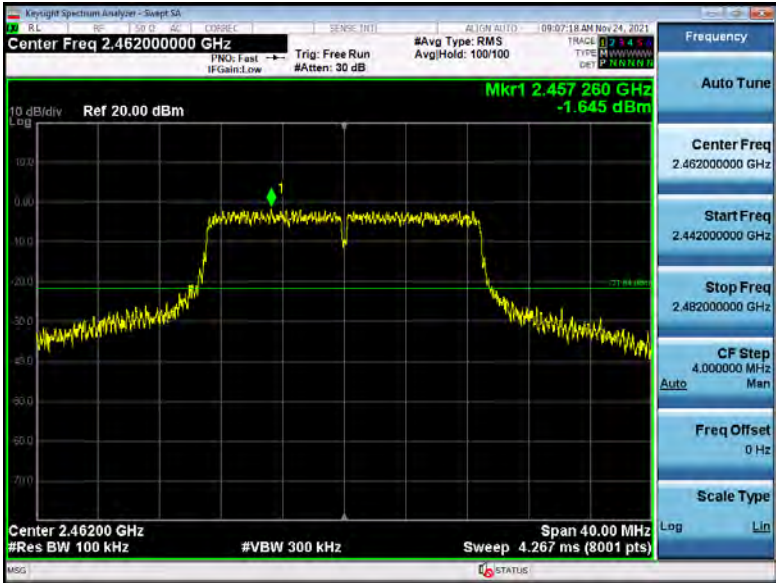

802.11n(HT40) Lowest channel

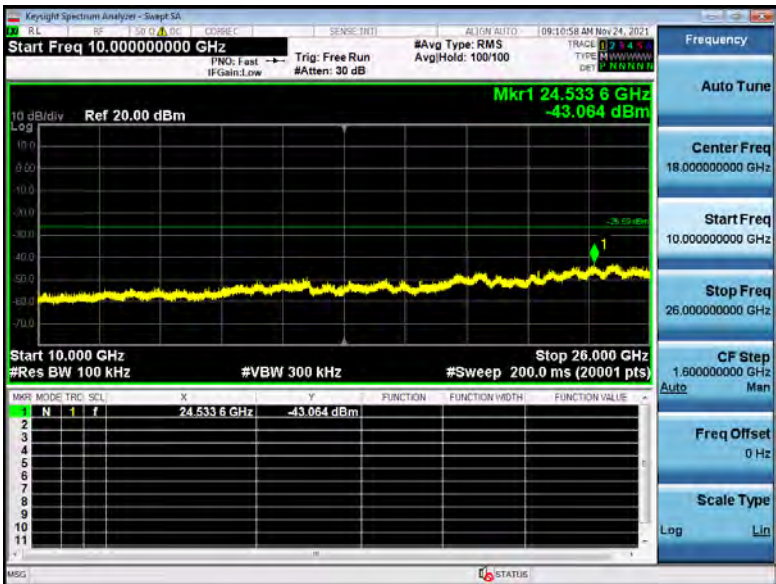
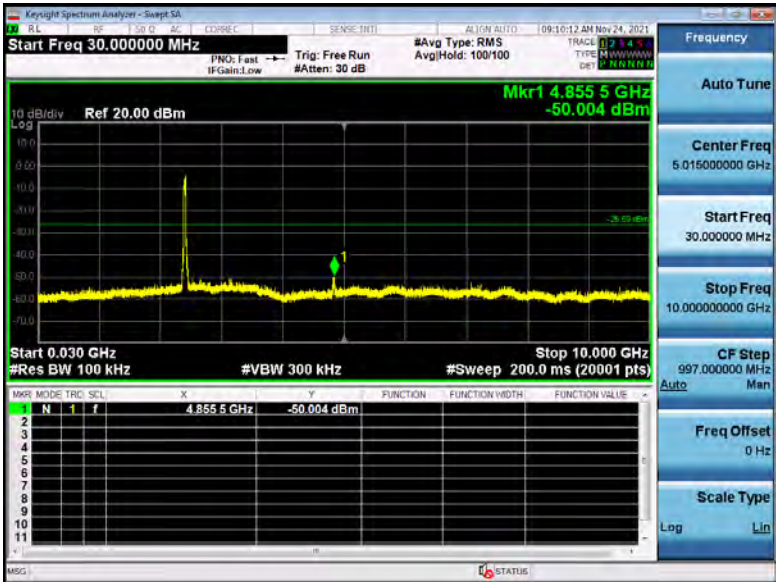
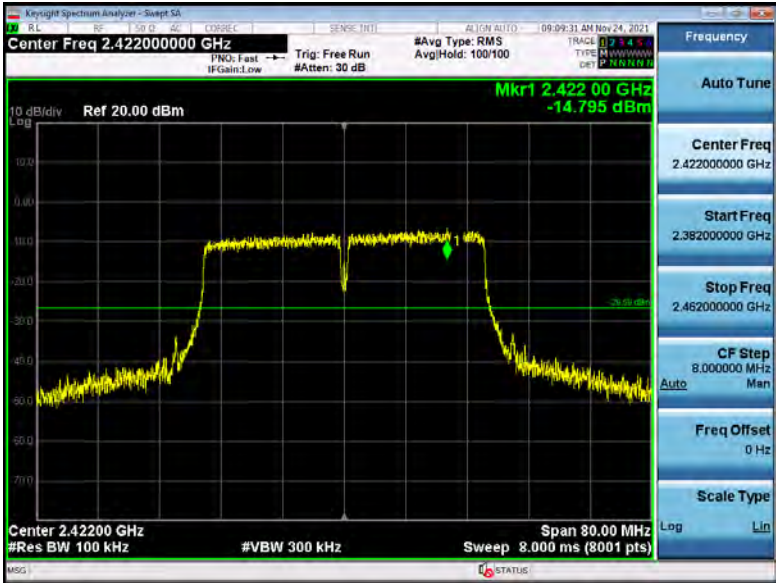

802.11n(HT40) Middle channel

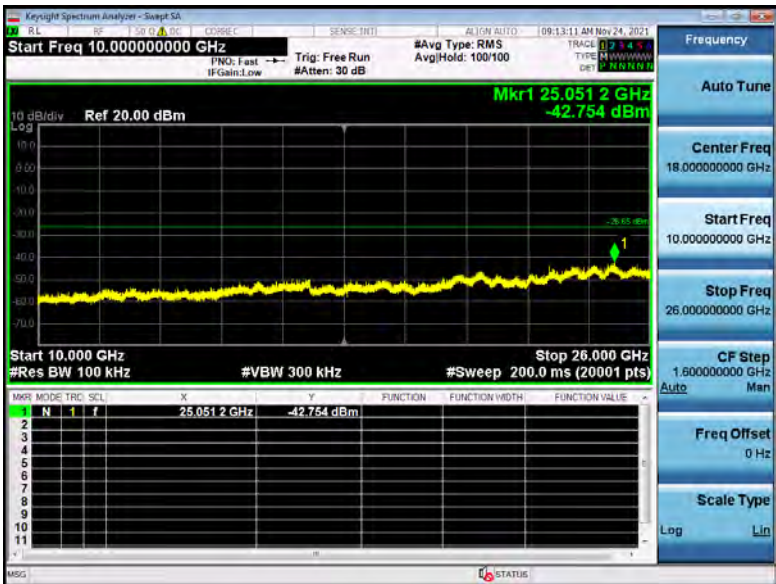
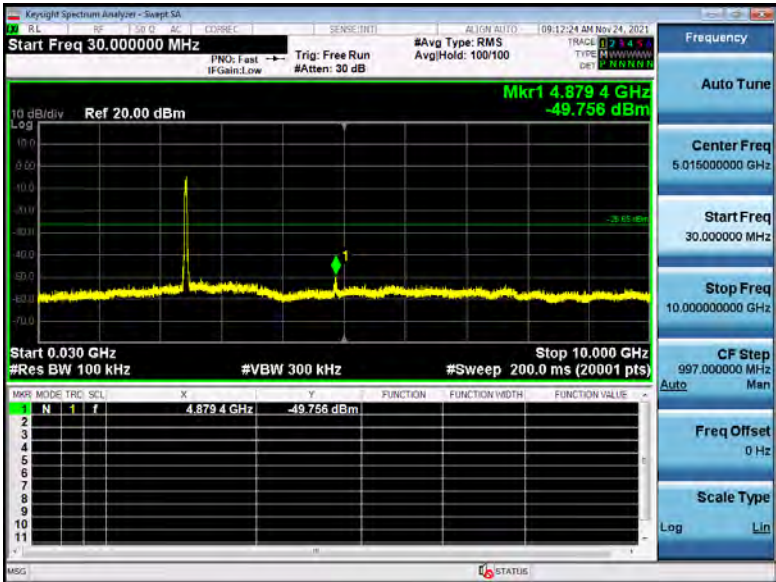
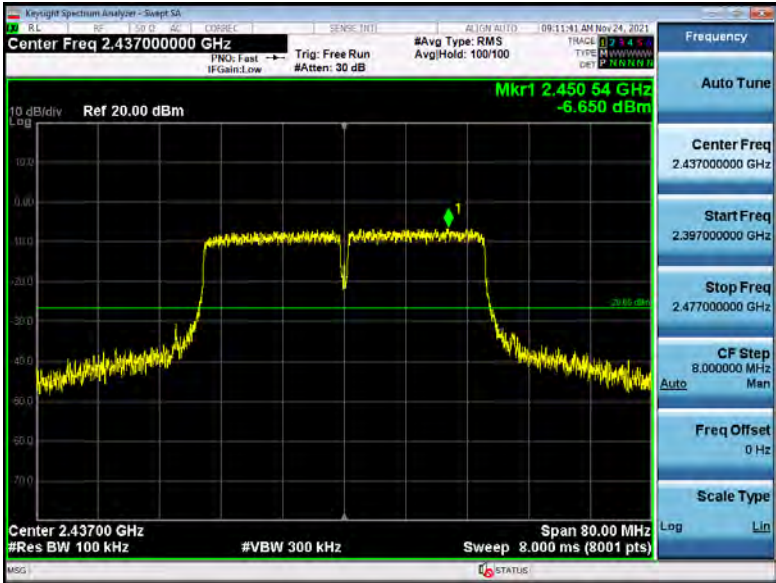

10. ANTENNA REQUIREMENT

Standard requirement:	FCC Part15 C Section 15.203 /247(c)
-----------------------	-------------------------------------

For intentional device, according to FCC 47 CFR Section 15.203, an intentional radiator shall be designed to ensure that no antenna other than that furnished by the responsible party shall be used with the device. And according to FCC 47 CFR Section 15.247, if transmitting antennas of directional gain greater than 6dBi are used, the power shall be reduced by the amount in dB that the directional gain of the antenna exceeds 6dBi.

Refer to statement below for compliance.

The manufacturer may design the unit so that the user can replace a broken antenna, but the use of a standard antenna jack or electrical connector is prohibited. Further, this requirement does not apply to intentional radiators that must be professionally installed.

Antenna Connected Construction

The FPC antenna used in the product is a permanently connected antenna that complies with the provisions of part 15.203 requirement in this section. The antenna used in this product is a FPC antenna, The directional gains of antenna used for transmitting is 2dBi.

EUT Antenna:

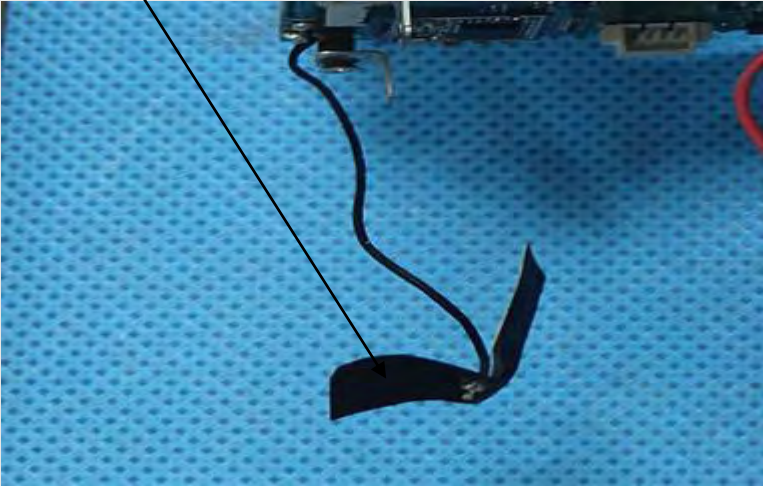

11. TEST SETUP PHOTO

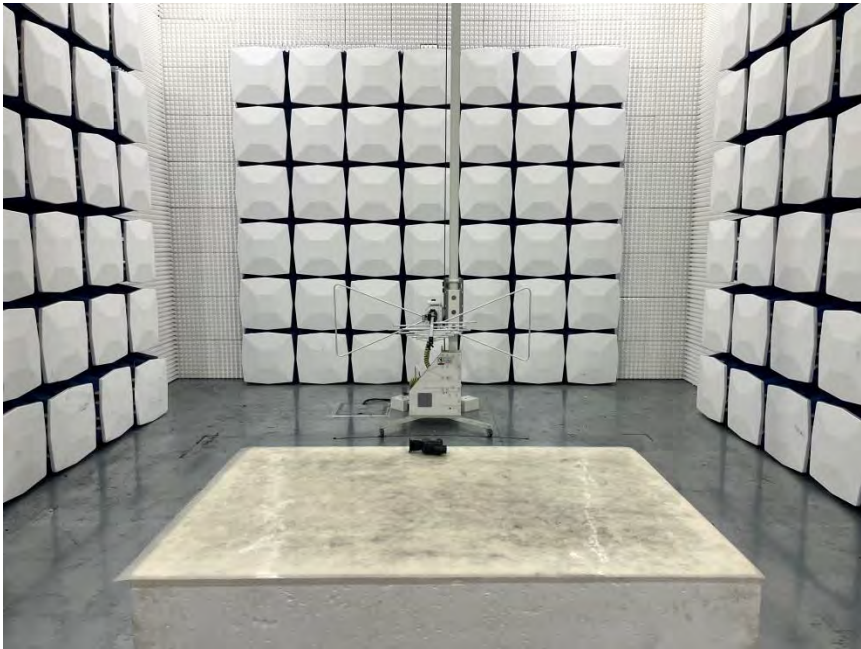

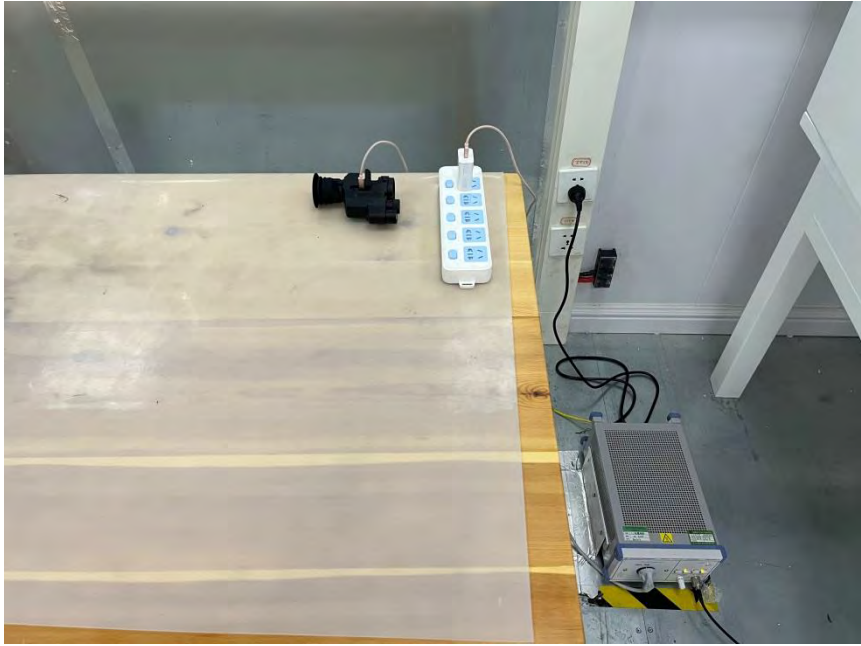

12. EUT CONSTRUCTIONAL DETAILS

Please refer to external photos file and internal photos file

******* END OF REPORT *******