



# FCC TEST REPORT

For

ZHENGZHOU YSAIR TECHNOLOGY CO.,LTD

Wireless call system

Test Model: TD020

Prepared for : ZHENGZHOU YSAIR TECHNOLOGY CO.,LTD  
Address : ROOM 709, SANJIANG BUILDING, NO.170 NANYANG ROAD, HUIJI DISTRICT, ZHENGZHOU HENAN CHINA

Prepared by : Shenzhen LCS Compliance Testing Laboratory Ltd.  
Address : 101, 201 Bldg A & 301 Bldg C, Juji Industrial Park Yabianxueziwei, Shajing Street, Baoan District, Shenzhen, 518000, China

Tel : (+86)755-82591330  
Fax : (+86)755-82591332  
Web : www.LCS-cert.com  
Mail : webmaster@LCS-cert.com

Date of receipt of test sample : June 10, 2022  
Number of tested samples : 2  
Serial number : Prototype  
Date of Test : June 10, 2022 ~ June 17, 2022  
Date of Report : June 22, 2022





<b>FCC TEST REPORT</b> <b>FCC CFR 47 PART 15 C(15.231)</b>	
<b>Report Reference No.</b> .....	<b>: LCSA060822075EA</b>
<b>Date of Issue</b> .....	<b>: June 22, 2022</b>
<b>Testing Laboratory Name</b> .....	<b>: Shenzhen LCS Compliance Testing Laboratory Ltd.</b>
<b>Address</b> .....	<b>: 101, 201 Bldg A &amp; 301 Bldg C, Juji Industrial Park Yabianxueziwei, Shajing Street, Baoan District, Shenzhen, 518000, China</b>
<b>Testing Location/ Procedure</b> .....	<b>: Full application of Harmonised standards <input checked="" type="checkbox"/></b> <b>Partial application of Harmonised standards <input type="checkbox"/></b> <b>Other standard testing method <input type="checkbox"/></b>
<b>Applicant's Name</b> .....	<b>: ZHENGZHOU YSAIR TECHNOLOGY CO.,LTD</b>
<b>Address</b> .....	<b>: ROOM 709, SANJIANG BUILDING, NO.170 NANYANG ROAD, HUIJI DISTRICT, ZHENGZHOU HENAN CHINA</b>
<b>Test Specification</b>	
<b>Standard</b> .....	<b>: FCC CFR 47 PART 15 Subpart C, ANSI C63.10-2013</b>
<b>Test Report Form No.</b> .....	<b>: LCSEMC-1.0</b>
<b>TRF Originator</b> .....	<b>: Shenzhen LCS Compliance Testing Laboratory Ltd.</b>
<b>Master TRF</b> .....	<b>: Dated 2011-03</b>
<b>Shenzhen LCS Compliance Testing Laboratory Ltd. All rights reserved.</b> This publication may be reproduced in whole or in part for non-commercial purposes as long as the Shenzhen LCS Compliance Testing Laboratory Ltd. is acknowledged as copyright owner and source of the material. Shenzhen LCS Compliance Testing Laboratory Ltd. takes no responsibility for and will not assume liability for damages resulting from the reader's interpretation of the reproduced material due to its placement and context.	
<b>Test Item Description</b> ..... <b>: Wireless call system</b>	
<b>Trade Mark</b> .....	<b>: RETEKES</b>
<b>Test Model</b> .....	<b>: TD020</b>
<b>Ratings</b> .....	<b>: 12V/27A Alkaline Battery</b>
<b>Result</b> .....	<b>: Positive</b>

**Compiled by:**

Jack Liu/ Administrator

**Supervised by:**

Jin Wang / Technique principal

**Approved by:**

Gavin Liang/ Manager





### FCC -- TEST REPORT

<b>Test Report No. :</b> LCSA060822075EA	June 22, 2022 Date of issue
--	--------------------------------

EUT.....	: Wireless call system
Test Model.....	: TD020
<b>Applicant.....</b>	<b>: ZHENGZHOU YSAIR TECHNOLOGY CO.,LTD</b>
Address.....	: ROOM 709, SANJIANG BUILDING, NO.170 NANYANG ROAD, HUIJI DISTRICT, ZHENGZHOU HENAN CHINA
Telephone.....	: /
Fax.....	: /
<b>Manufacturer.....</b>	<b>: ZHENGZHOU YSAIR TECHNOLOGY CO.,LTD</b>
Address.....	: ROOM 709, SANJIANG BUILDING, NO.170 NANYANG ROAD, HUIJI DISTRICT, ZHENGZHOU HENAN CHINA
Telephone.....	: /
Fax.....	: /
<b>Factory.....</b>	<b>: /</b>
Address.....	: /
Telephone.....	: /
Fax.....	: /

<b>Test Result</b>	<b>Positive</b>
--------------------	-----------------

The test report merely corresponds to the test sample.

It is not permitted to copy extracts of these test result without the written permission of the test laboratory.





### Revision History

Report Version	Issue Date	Revision Content	Revised By
000	June 22, 2022	Initial Issue	--





# TABLE OF CONTENTS

- 1. GENERAL INFORMATION..... 6**
  - 1.1. DESCRIPTION OF DEVICE (EUT) ..... 6
  - 1.2. OBJECTIVE..... 6
  - 1.3. ENVIRONMENTAL CONDITIONS ..... 6
  - 1.4. HOST SYSTEM CONFIGURATION LIST AND DETAILS ..... 6
  - 1.5. EXTERNAL I/O PORT ..... 6
  - 1.6. EUT OPERATION..... 7
  - 1.7. ANTENNA SYSTEM..... 7
  - 1.8. DESCRIPTION OF TEST FACILITY ..... 7
  - 1.9. STATEMENT OF THE MEASUREMENT UNCERTAINTY ..... 7
- 2. TEST METHODOLOGY ..... 8**
  - 2.1. EUT CONFIGURATION ..... 8
  - 2.2. EUT EXERCISE ..... 8
  - 2.3. GENERAL TEST PROCEDURES ..... 8
  - 2.4. INSTRUMENT CALIBRATION ..... 8
  - 2.5. TEST MODE ..... 8
- 3. SYSTEM TEST CONFIGURATION ..... 9**
  - 3.1. JUSTIFICATION ..... 9
  - 3.2. EUT EXERCISE SOFTWARE ..... 9
  - 3.3. SPECIAL ACCESSORIES ..... 9
  - 3.4. BLOCK DIAGRAM/SCHEMATICS..... 9
  - 3.5. EQUIPMENT MODIFICATIONS ..... 9
  - 3.6. TEST SETUP ..... 9
- 4. SUMMARY OF TEST RESULTS ..... 10**
- 5. TEST ITEMS AND RESULTS ..... 11**
  - 5.1. TRANSMITTER DEACTIVATION TIME ..... 11
  - 5.2. TRANSMITTER FIELD STRENGTH OF EMISSIONS ..... 13
  - 5.3. 20DB BANDWIDTH EMISSIONS ..... 23
  - 5.4. DUTY CYCLE ..... 24
  - 5.5. POWER LINE CONDUCTED EMISSIONS ..... 25
  - 5.6. ANTENNA REQUIREMENT ..... 26
- 6. LIST OF MEASURING EQUIPMENTS ..... 27**
- 7. TEST SETUP PHOTOGRAPHS ..... 28**
- 8. EXTERIOR PHOTOGRAPHS OF THE EUT..... 28**
- 9. INTERIOR PHOTOGRAPHS OF THE EUT..... 28**





# 1. GENERAL INFORMATION

## 1.1. Description of Device (EUT)

EUT : Wireless call system  
 Test Model : TD020  
 Hardware version : V1  
 Software version : V1.0  
 Power Supply : 12V/27A Alkaline Battery  
 433MHz Operation frequency : 433.92MHz  
 Modulation Type : ASK  
 Channel Number : 1  
 Antenna Type : Internal Antenna  
 Antenna Gain : 0dBi (Max)

## 1.2. Objective

The primary objective of the manufacturer is compliance with Subpart C of Part 15 of FCC Rules for the radiated and conducted emissions of intentional radiator. Certification of these devices is required as a prerequisite to marketing as defined in Part 2 the FCC Rules Certification is a procedure where the manufacturer or a contracted laboratory makes measurements and submits the test data and technical information to the FCC. The FCC issues a grant of equipment authorization upon successful completion of their review of the submitted documents. Once the equipment authorization has been obtained, the label indicating compliance must be attached to all identical units, which are subsequently manufactured. Maintenance of compliance is the responsibility of the manufacturer. Any modification of the product which may result in increased emissions should be checked to ensure compliance has been maintained (i.e., printed circuit board layout changes, different line filter, different power supply, harnessing or I/O cable changes, etc.).

## 1.3. Environmental Conditions

During the measurement the environmental conditions were within the listed ranges:

- Temperature: 15-35°C
- Humidity: 30-60 %
- Atmospheric pressure: 86-106 kPa

## 1.4. Host System Configuration List and Details

Manufacturer	Description	Model	Serial Number	Certificate
---	---	---	---	---

## 1.5. External I/O Port

I/O Port Description	Quantity	Cable
---	---	---





### 1.6. EUT Operation

The EUT was placed in a RF test mode for testing of the transmitter and in normal mode of operation for testing the digital circuitry and receiver.

### 1.7. Antenna System

The directional gains of antenna used for transmitting is 0dBi, and EUT uses an external antenna which is permanently attached.

### 1.8. Description of Test Facility

Site Description  
 EMC Lab. : NVLAP Accreditation Code is 600167-0.  
 FCC Designation Number is CN5024.  
 CAB identifier is CN0071.  
 CNAS Registration Number is L4595.  
 Test Firm Registration Number: 254912.

The 3m-Semi anechoic test site fulfils CISPR 16-1-4 according to ANSI C63.4:2014 and CISPR 16-1-4:2010 SVSWR requirement for radiated emission above 1GHz.

### 1.9. Statement of The Measurement Uncertainty

ISO Guide 17025 requires that an estimate of the measurement uncertainties associated with the emissions test results be included in the report. The measurement uncertainties given below are based on a 95% confidence level and were calculated in accordance with NAMAS document NIS 81.

Test Item	Frequency Range	Uncertainty	Note
Radiation Uncertainty	9KHz~30MHz	±3.10dB	(1)
	30MHz~200MHz	±2.96dB	(1)
	200MHz~1000MHz	±3.10dB	(1)
	1GHz~26.5GH	±4.20dB	(1)
Conduction Uncertainty	150kHz~30MHz	±1.63dB	(1)
Power disturbance	30MHz~300MHz	±1.60dB	(1)

(1). This uncertainty represents an expanded uncertainty expressed at approximately the 95% confidence level using a coverage factor of k=2.





## 2. TEST METHODOLOGY

All measurements contained in this report were conducted with ANSI C63.10-2013, American National Standard of Procedures for Compliance Testing of Unlicensed Wireless Devices.

The radiated testing was performed at an antenna-to-EUT distance of 3 meters. All radiated and conducted emissions measurement was performed at Shenzhen LCS Compliance Testing Laboratory Ltd.

### 2.1. EUT Configuration

The EUT configuration for testing is installed on RF field strength measurement to meet the Commissions requirement and operating in a manner that intends to maximize its emission characteristics in a continuous normal application.

### 2.2. EUT Exercise

The EUT was operated in the normal operating mode. The TX frequency that was fixed which was for the purpose of the measurements.

According to its specifications, the EUT must comply with the requirements of the Section 15.203, 15.205, 15.207, 15.209 and 15.231 under the FCC Rules Part 15 Subpart C.

### 2.3. General Test Procedures

#### 2.3.1 Conducted Emissions

The EUT is placed on the turntable, which is 0.8 m above ground plane. According to the requirements in Section 13.1.4.1 of ANSI C63.10 Conducted emissions from the EUT measured in the frequency range between 0.15 MHz and 30MHz using Quasi-peak and average detector modes.

#### 2.3.2 Radiated Emissions

The EUT is placed on a turn table, which is 0.8 m above ground plane and for below 1GHz and 1.5m for above 1GHz. The turntable shall rotate 360 degrees to determine the position of maximum emission level. EUT is set 3m away from the receiving antenna, which varied from 1m to 4m to find out the highest emission. And also, each emission was to be maximized by changing the polarization of receiving antenna both horizontal and vertical. In order to find out the maximum emissions, exploratory radiated emission measurements were made according to the requirements in Section 13.1.4.1 of ANSI C63.10

### 2.4. Instrument Calibration

All test equipment is regularly checked to ensure that performance is maintained in accordance with the manufacturer's specifications. All antennas are calibrated at regular intervals with respect to tuned half-wave dipoles. An exhibit of this report contains the list of test equipment used and calibration information.

### 2.5. Test Mode

The EUT has been tested under engineering mode. The field strength of radiation emission was measured in the following position: EUT stand-up position (Y axis), lie-down position (X, Z axis). The worst case of X axis was reported.

A new battery supplied DC 9.0V power to the EUT for testing.

\*\*\*Note: Using a temporary antenna connector for the EUT when conducted measurements are performed.



Shenzhen LCS Compliance Testing Laboratory Ltd.

Add: 101, 201 Bldg A & 301 Bldg C, Juji Industrial Park Yabianxueziwei, Shajing Street, Baoan District, Shenzhen, 518000, China

Tel: +(86) 0755-82591330 | E-mail: webmaster@lcs-cert.com | Web: www.lcs-cert.com

Scan code to check authenticity





### 3. SYSTEM TEST CONFIGURATION

#### 3.1. Justification

The system was configured for testing in a continuous transmits condition.

#### 3.2. EUT Exercise Software

N/A

#### 3.3. Special Accessories

N/A

#### 3.4. Block Diagram/Schematics

Please refer to the related document

#### 3.5. Equipment Modifications

Shenzhen LCS Compliance Testing Laboratory Ltd. has not done any modification on the EUT.

#### 3.6. Test Setup

Please refer to the test setup photo.





### 4. SUMMARY OF TEST RESULTS

Rules	Description of test	Result
§15.203	Antenna Requirement	Compliant
§15.205	Restricted Band	Compliant
§15.209	General Requirement	Compliant
§15.231 (b)	Radiated Emissions	Compliant
§15.231 (c)	20dB Bandwidth Testing	Compliant
§15.231 (a)(1)	Deactivation Testing	Compliant
§15.231	Duty cycle Factor	Compliant
§15.207	Conducted Emissions	N/A

Note: All test modes were taken into consideration, but we only recorded the worst case in this report.





### 5. TEST ITEMS AND RESULTS

#### 5.1. Transmitter Deactivation Time

FCC 15.231 (a)

##### 5.1.1. Limit

A manually operated transmitter shall employ a switch that will automatically deactivate the transmitter within not more than 5 seconds of being released.

##### 5.1.2. Test Procedure

Maximizing procedure was performed on the highest emissions to ensure that the EUT complied with all installation combinations.

##### 5.1.3. Test Results

Temperature	23.5°C	Humidity	52.2%
Test Engineer	Bill Zhu	Configurations	TX Mode
Frequency (MHz)	Activation Time (s)	Limit: not more than 5 seconds of being released (s)	Conclusion
433.92	0.04397	5	PASS

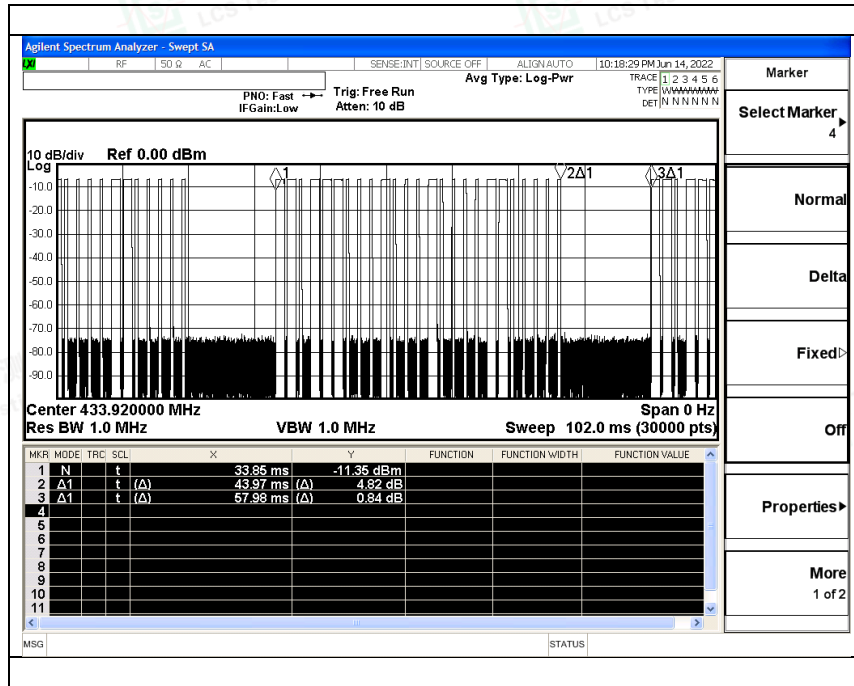





### 5.2. Transmitter Field Strength of Emissions

#### 5.2.1. Limit

##### FCC §15.231 (b)

In addition to the provisions of § 15.205, the field strength of emissions from Intentional radiators operated under this section shall not exceed the following:

Fundamental frequency (MHz)	Field Strength of Fundamental (microvolt/meter)	Field Strength of spurious emissions (microvolt/meter)
40.66-40.70	2,250	225
70-130	1,250	125
130-174	1,250 to 3,750	125 to 375
174-260	3,750	375
260-470	3,750 to 12,500	375 to 1,250
Above 470	12,500	1,250

[Where F is the frequency in MHz, the formulas for calculating the maximum permitted fundamental field strengths are as follows: for the band 130-174 MHz,  $\mu\text{V/m}$  at 3 meters =  $56.81818(F) - 6136.3636$ ; for the band 260-470 MHz,  $\mu\text{V/m}$  at 3 meters =  $41.6667(F) - 7083.3333$ . The maximum permitted unwanted emission level is 20 dB below the maximum permitted fundamental level.]

§15.205 (a) Except as shown in paragraph (d) of this section, only spurious emissions are permitted in any of the frequency bands listed below:

MHz	MHz	MHz	GHz
0.090-0.110	16.42-16.423	608-614	4.5-5.15
0.495-0.505	16.69475-16.68525	960-1240	5.35-5.46
2.1735-2.1905	16.80425-16.80475	1300-1427	7.25-7.75
4.125-4.128	25.525-67	1435-1626.5	8.025-8.5
4.17725-4.17775	37.5-38.25	1645.5-1646.5	9.0-9.2
4.20725-4.20775	73-74.6	1660-1710	9.3-9.5
6.215-6.218	74.8-75.2	1718.8-1722.2	10.6-12.7
6.26775-6.26825	108-121.94	2200-2300	13.25-13.4
6.31175-6.31225	123-138	2310-2390	14.47-14.5
8.291-8.294	149.9-150.05	2483.5-2500	15.35-16.2
8.362-8.366	156.52475-156.52525	2655-2900	17.7-21.4
8.37625-8.38675	156.7-156.9	3260-3267	22.01-23.12
8.41425-8.41475	162.0125167.17	3332-3339	23.6-24.0
12.29-12.293	167.72-173.2	3345.8-3358	31.2-31.8
12.51975-12.52025	240-285	3600-4400	36.43-36.5
12.57675-12.57725	322-335.4		( <sup>2</sup> )
13.36-13.41	399.9-410		

1. Until February 1, 1999, this restricted band shall be 0.490-0.510 MHz.

2. Above 38.6

§15.205 (b) Except as provided in paragraphs (d) and (e), the field strength of emissions appearing within these frequency bands shall not exceed the limits shown in Section 15.209. At frequencies equal to or less than 1000 MHz, compliance with the limits in Section 15.209 shall be demonstrated using measurement instrumentation employing a CISPR quasi peak detector. Above 1000 MHz, compliance with the emission limits in Section 15.209 shall be demonstrated based on the average value of the measured emissions. The provisions in Section 15.35 apply to these measurements.





§15.209 (a) Except as provided elsewhere in this Subpart, the emissions from an intentional radiator shall not exceed the field strength levels specified in the following table:

Frequency (MHz)	Field Strength (microvolts/meter)	Measurement Distance (meters)
0.009-0.490	2400/F (KHz)	300
0.490-1.705	24000 (KHz)	30
1.705-30.0	30	30
30-88	100**	3
88-216	150**	3
216-960	200**	3
Above 960	500	3

\*\* Except as provided in paragraph (g), fundamental emissions from intentional radiators operating under this Section shall not be located in the frequency bands 54 72 MHz, 76 88 MHz, 174 216 MHz or 470 806 MHz. However, operation within these frequency bands is permitted under other sections of this Part, e.g., Sections 15.231 and 15.241.

§15.209 (b) In the emission table above, the tighter limit applies at the band edges.

### 5.2.2. Measuring Instruments and Setting

Please refer to section 6 of equipments list in this report. The following table is the setting of spectrum analyzer and receiver.

Spectrum Parameter	Setting
Attenuation	Auto
Start Frequency	1000 MHz
Stop Frequency	10th carrier harmonic
RB / VB (Emission in restricted band)	1MHz / 1MHz for Peak, 1 MHz / 10Hz for Average
RB / VB (Emission in non-restricted band)	1MHz / 1MHz for Peak, 1 MHz / 10Hz for Average

Spectrum Parameter	Setting
Attenuation	Auto
Start ~ Stop Frequency	9kHz~150kHz / RB 200Hz for QP
Start ~ Stop Frequency	150kHz~30MHz / RB 9kHz for QP
Start ~ Stop Frequency	30MHz~1000MHz / RB 120kHz for QP





### 5.2.3. Test Procedures

#### 1) Sequence of testing 9 kHz to 30 MHz

##### Setup:

- The equipment was set up to simulate a typical usage like described in the user manual or described by manufacturer.
- If the EUT is a tabletop system, a rotatable table with 1.5 m height is used.
- If the EUT is a floor standing device, it is placed on the ground.
- Auxiliary equipment and cables were positioned to simulate normal operation conditions.
- The AC power port of the EUT (if available) is connected to a power outlet below the turntable.
- The measurement distance is 3 meter.
- The EUT was set into operation.

##### Premeasurement:

- The turntable rotates from 0° to 315° using 45° steps.
- The antenna height is 1.0 meter.
- At each turntable position the analyzer sweeps with peak detection to find the maximum of all emissions

##### Final measurement:

- Identified emissions during the premeasurement the software maximizes by rotating the turntable position (0° to 360°) and by rotating the elevation axes (0° to 360°).
- The final measurement will be done in the position (turntable and elevation) causing the highest emissions with QPK detector.
- The final levels, frequency, measuring time, bandwidth, turntable position, correction factor, margin to the limit and limit will be recorded. Also a plot with the graph of the premeasurement and the limit will be stored.





## 2) Sequence of testing 30 MHz to 1 GHz

### Setup:

- The equipment was set up to simulate a typical usage like described in the user manual or described by manufacturer.
- If the EUT is a tabletop system, a table with 0.8 m height is used, which is placed on the ground plane.
- If the EUT is a floor standing device, it is placed on the ground plane with insulation between both.
- Auxiliary equipment and cables were positioned to simulate normal operation conditions.
- The AC power port of the EUT (if available) is connected to a power outlet below the turntable.
- The measurement distance is 3 meter.
- The EUT was set into operation.

### Premeasurement:

- The turntable rotates from 0° to 315° using 45° steps.
- The antenna is polarized vertical and horizontal.
- The antenna height changes from 1 to 3 meter.
- At each turntable position, antenna polarization and height the analyzer sweeps three times in peak to find the maximum of all emissions.

### Final measurement:

- The final measurement will be performed with minimum the six highest peaks.
- According to the maximum antenna and turntable positions of premeasurement the software maximize the peaks by changing turntable position ( $\pm 45^\circ$ ) and antenna movement between 1 and 4 meter.
- The final measurement will be done with QP detector with an EMI receiver.
- The final levels, frequency, measuring time, bandwidth, antenna height, antenna polarization, turntable angle, correction factor, margin to the limit and limit will be recorded. Also a plot with the graph of the premeasurement with marked maximum final measurements and the limit will be stored.







### 3) Sequence of testing 1 GHz to 12.75 GHz

#### Setup:

- The equipment was set up to simulate a typical usage like described in the user manual or described by manufacturer.
- If the EUT is a tabletop system, a rotatable table with 1.5 m height is used.
- If the EUT is a floor standing device, it is placed on the ground plane with insulation between both.
- Auxiliary equipment and cables were positioned to simulate normal operation conditions.
- The AC power port of the EUT (if available) is connected to a power outlet below the turntable.
- The measurement distance is 3 meter.
- The EUT was set into operation.

#### Premeasurement:

- The turntable rotates from 0° to 315° using 45° steps.
- The antenna is polarized vertical and horizontal.
- The antenna height is 1.5 meter.
- At each turntable position and antenna polarization the analyzer sweeps with peak detection to find the maximum of all emissions.

#### Final measurement:

- The final measurement will be performed with minimum the six highest peaks.
- According to the maximum found antenna polarisation and turntable position of the premeasurement the software maximizes the peaks by rotating the turntable position (0° to 360°). This measurement is repeated for different EUT-table positions (0° to 150° in 30°-steps). This procedure is repeated for both antenna polarisations.
- The final measurement will be done in the position (turntable, EUT-table and antenna polarization) causing the highest emissions with Peak and RMS detector.
- The final levels, frequency, measuring time, bandwidth, turntable position, EUT-table position, antenna polarization, correction factor, margin to the limit and limit will be recorded. Also a plot with the graph of the premeasurement with marked maximum final measurements and the limit will be stored.



Shenzhen LCS Compliance Testing Laboratory Ltd.

Add: 101, 201 Bldg A & 301 Bldg C, Juji Industrial Park Yabianxueziwei, Shajing Street, Baoan District, Shenzhen, 518000, China

Tel: +(86) 0755-82591330 | E-mail: webmaster@lcs-cert.com | Web: www.lcs-cert.com

Scan code to check authenticity

### 5.2.4 Block Diagram of Test Setup

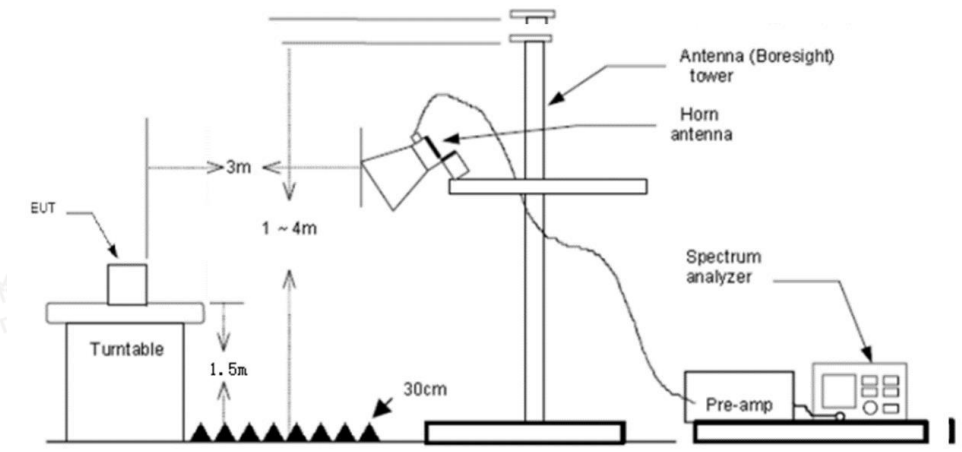
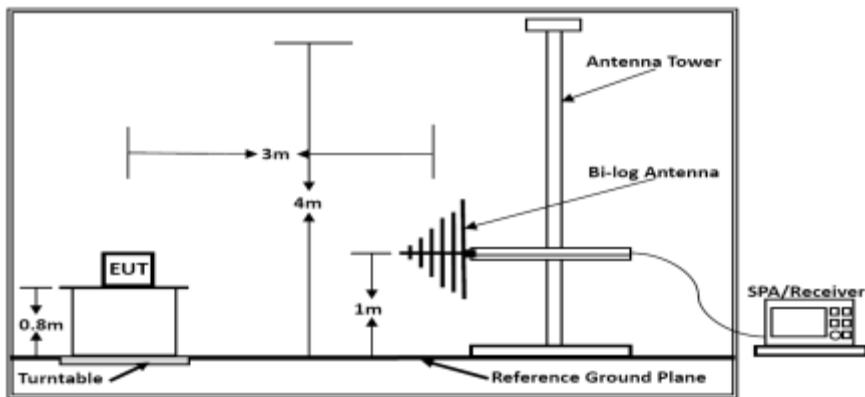
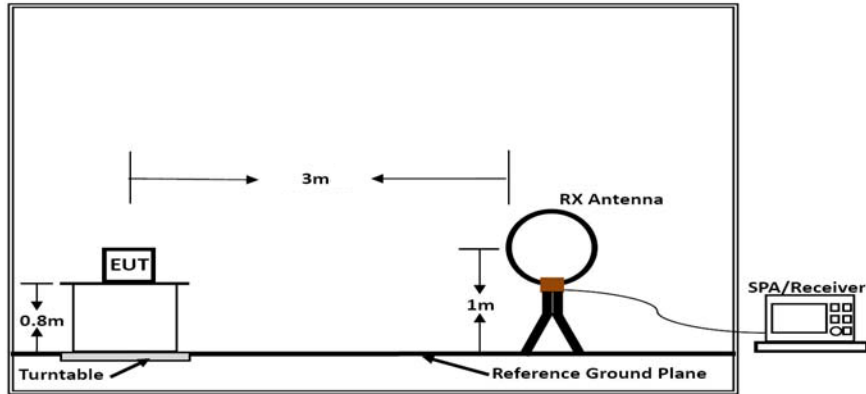



### 5.2.5. EUT Operation during Test

The EUT was programmed to be in continuously transmitting mode.

### 5.2.6. Results of Radiated Emissions (9 kHz~30MHz)

Temperature	23.8°C	Humidity	52.2%
Test Engineer	Bill Zhu	Configurations	TX Mode

Freq. (MHz)	Level (dBuV)	Over Limit (dB)	Over Limit (dBuV)	Remark
-	-	-	-	See Note

Note:

The amplitude of spurious emissions which are attenuated by more than 20 dB below the permissible value has no need to be reported.

Distance extrapolation factor = 40 log (specific distance / test distance) (dB);

Limit line = specific limits (dBuV) + distance extrapolation factor.





5.2.7. Results of Radiated Emissions (30MHz~1GHz)

Temperature	23.8°C	Humidity	52.2%
Test Engineer	Bill Zhu	Configurations	TX Mode

Horizontal

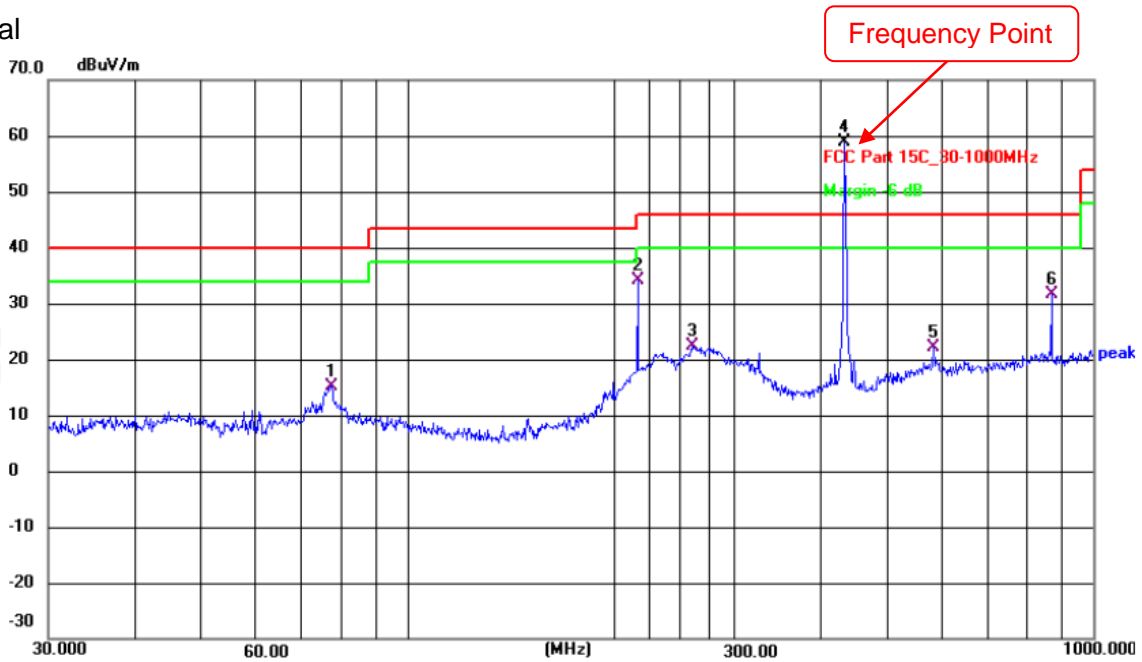

No.	Frequency (MHz)	Reading (dBuV)	Factor (dB/m)	Level (dBuV/m)	Limit (dBuV/m)	Margin (dB)	Detector
1	77.5926	34.96	-19.78	15.18	40.00	-24.82	QP
2	216.7828	51.10	-16.97	34.13	46.00	-11.87	QP
3	261.0581	37.84	-15.49	22.35	46.00	-23.65	QP
4	434.0649	72.63	-13.81	58.82	46.00	12.82	peak
5	584.7894	32.78	-10.69	22.09	46.00	-23.91	QP
6	869.1300	40.28	-8.75	31.53	46.00	-14.47	peak

Fundamental and Harmonics Result

Frequency (MHz)	Peak Level (dBuV/m)	AV Factor (dBuV/m) (see Section 5.4)	Average Level (dBuV/m)	Limit (dBuV/m) (average)	Limit (dBuV/m) (Peak)	Conclusion
434.065	58.82	-9.67	49.15	80.83	100.83	PASS
869.130	31.53	-9.67	21.86	60.83	80.83	PASS





Vertical

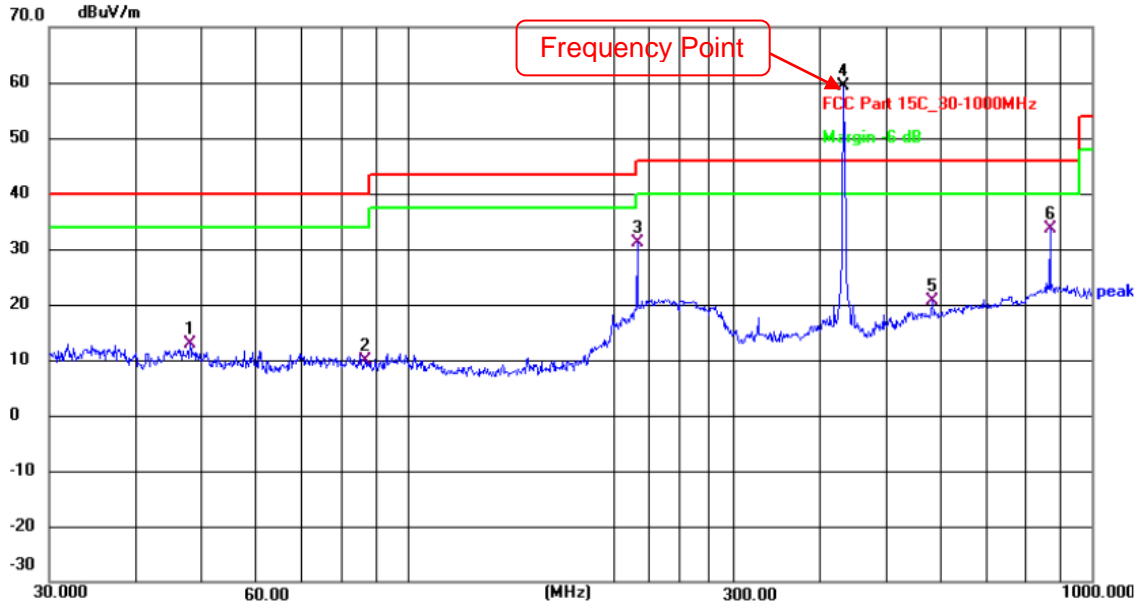

No.	Frequency (MHz)	Reading (dBuV)	Factor (dB/m)	Level (dBuV/m)	Limit (dBuV/m)	Margin (dB)	Detector
1	48.1625	29.85	-16.98	12.87	40.00	-27.13	QP
2	86.8067	29.02	-19.20	9.82	40.00	-30.18	QP
3	216.7828	48.10	-16.97	31.13	46.00	-14.87	QP
4	434.0649	73.76	-14.44	59.32	46.00	13.32	peak
5	584.7894	31.28	-10.69	20.59	46.00	-25.41	QP
6	869.1300	42.28	-8.75	33.53	46.00	-12.47	peak

Fundamental and Harmonics Result

Frequency (MHz)	Peak Level (dBμV/m)	AV Factor(dBμV/m) (see Section 5.4)	Average Level (dBμV/m)	Limit(dBμV/m) (average)	Limit(dBμV/m) (Peak)	Conclusion
434.065	59.32	-9.67	49.65	80.83	100.83	PASS
869.130	33.53	-9.67	23.86	60.83	80.83	PASS

Note:

1. All reading are Quasi-peak values.
2. Measured = Reading + Antenna Factor + Cable Loss
3. The emission that are 20dB below the official limit are not reported
4. \* - means fundamental frequency
5. \*\* - means harmonic frequency
6. AV values = Peak values + Duty cycle factor





5.2.8. Results of Radiated Emissions (Above 1GHz)

Temperature	23.5°C	Humidity	52.2%
Test Engineer	Bill Zhu	Configurations	TX Mode

Peak Value:				
Frequency (MHz)	Level (dBuV/m)	Limit Line (dBuV/m)	Over limit (dB)	Polarization
1301.49	47.32	74.00	-26.68	Horizontal
1733.79	35.21	74.00	-38.79	Horizontal
2168.69	42.31	74.00	-31.69	Vertical
1299.98	47.32	74.00	-26.68	Vertical

Average Value:						
Frequency (MHz)	Peak Level (dBuV/m)	average factor	Average value (dBuV/m)	Limit Line (dBuV/m)	Over limit (dB)	Polarization
1301.49	47.32	-9.67	37.65	54.00	-16.35	Horizontal
1733.79	35.21	-9.67	25.54	54.00	-28.46	Horizontal
2168.69	42.31	-9.67	32.64	54.00	-21.36	Vertical
1299.98	47.32	-9.67	37.65	54.00	-16.35	Vertical

1. Measuring frequencies from 9k~10th harmonic (ex. 5GHz), No emission found between lowest internal used/generated frequency to 30MHz.
2. Radiated emissions measured in frequency range from 9k~10th harmonic (ex. 5GHz) were made with an instrument using Peak detector mode.
3. Data of measurement within this frequency range shown "---" in the table above means the reading of emissions are attenuated more than 20dB below the permissible limits or the field strength is too small to be measured.
4. Average value=peak reading level + average factor.





### 5.3. 20dB Bandwidth Emissions

FCC 15.231 (c)

#### 5.3.1. Limit

The bandwidth of the emission shall be no wider than 0.25% of the center frequency for devices operating above 70 MHz and below 900 MHz. Bandwidth is determined at the points 20 dB down from the modulated carrier.

#### 5.3.2. Test Procedure

With the EUT's antenna attached, the EUT's 20dB Bandwidth power was received by the test antenna which was connected to the spectrum analyzer with the START and STOP frequencies set to the EUT's operation band.

#### 5.3.3. Test Data

Temperature	23.5°C	Humidity	52.2%
Test Engineer	Bill Zhu	Configurations	TX Mode

Center Frequency of operation MHz	Maximum allowed bandwidth kHz	Measured 20dB bandwidth kHz	Result
433.92	1084.8	55.92	PASS
<b>Maximum allowed bandwidth:</b>	<input checked="" type="checkbox"/> 0.25% of the centre operating frequency <input type="checkbox"/> 0.5% of the centre operating frequency		
<b>RBW:</b>	<input checked="" type="checkbox"/> 10kHz <input type="checkbox"/> 100kHz <input type="checkbox"/> other kHz		
<b>VBW:</b>	<input checked="" type="checkbox"/> 30kHz <input type="checkbox"/> 300kHz <input type="checkbox"/> other kHz		

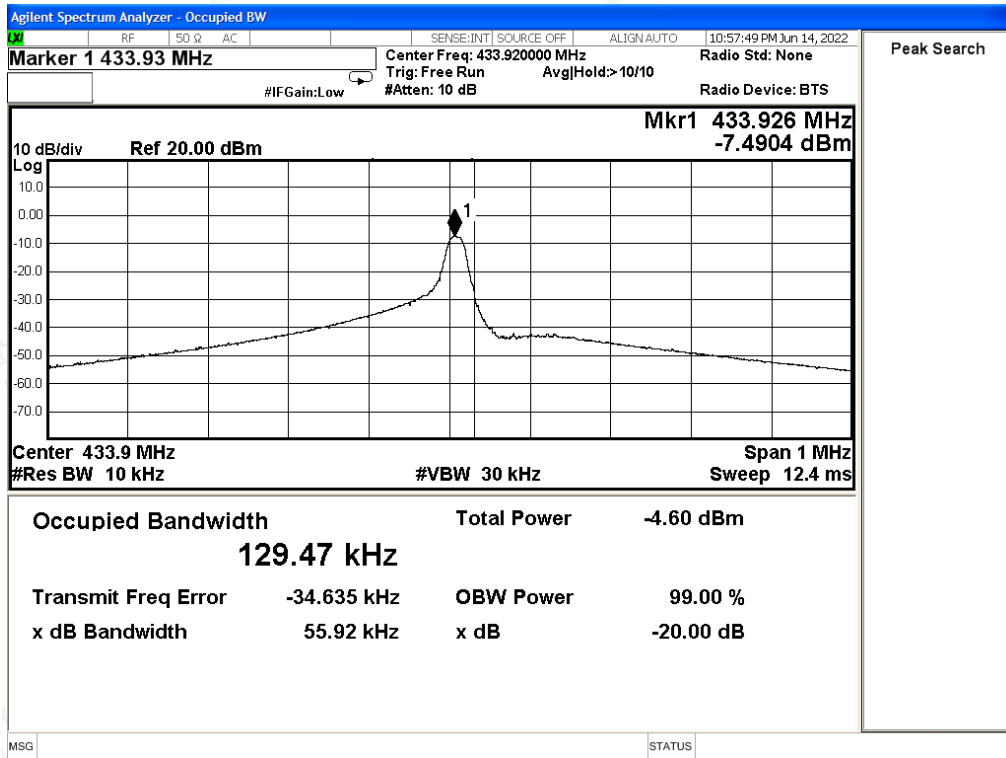



### 5.4. Duty cycle

#### 5.4.1. Limit

No dedicated limit specified in the Rules.

#### 5.4.2. Test Procedure

5.4.2.1. Place the EUT on the table and set it in transmitting mode.

5.4.2.2. Remove the antenna from the EUT and then connect a low loss RF cable from the antenna port to the spectrum analyzer.

5.4.2.3. Set centre frequency of spectrum analyzer=operating frequency.

5.4.2.4. Set the spectrum analyzer as RBW=1MHz,VBW=1MHz,Span=0Hz, Adjust Sweep=Auto.

5.4.2.5. Repeat above procedures until all frequency measured was complete.

#### 5.4.3. Test Data

$$T_{on} = 1.34 \times 9 + 0.4366 \times 16(\text{ms}) = 19.0456(\text{ms})$$

$$T_p = 57.98(\text{ms})$$

$$\text{The duty cycle} = 19.0456 / 57.98 = 32.85\%$$

$$\text{Average Correction Factory} = 20\log(T_{on}/T_p) = 20\log(0.3285) = -9.67\text{dB}$$

Test plot of Duty cycle (non-periodic and period (T) is less than 100ms)

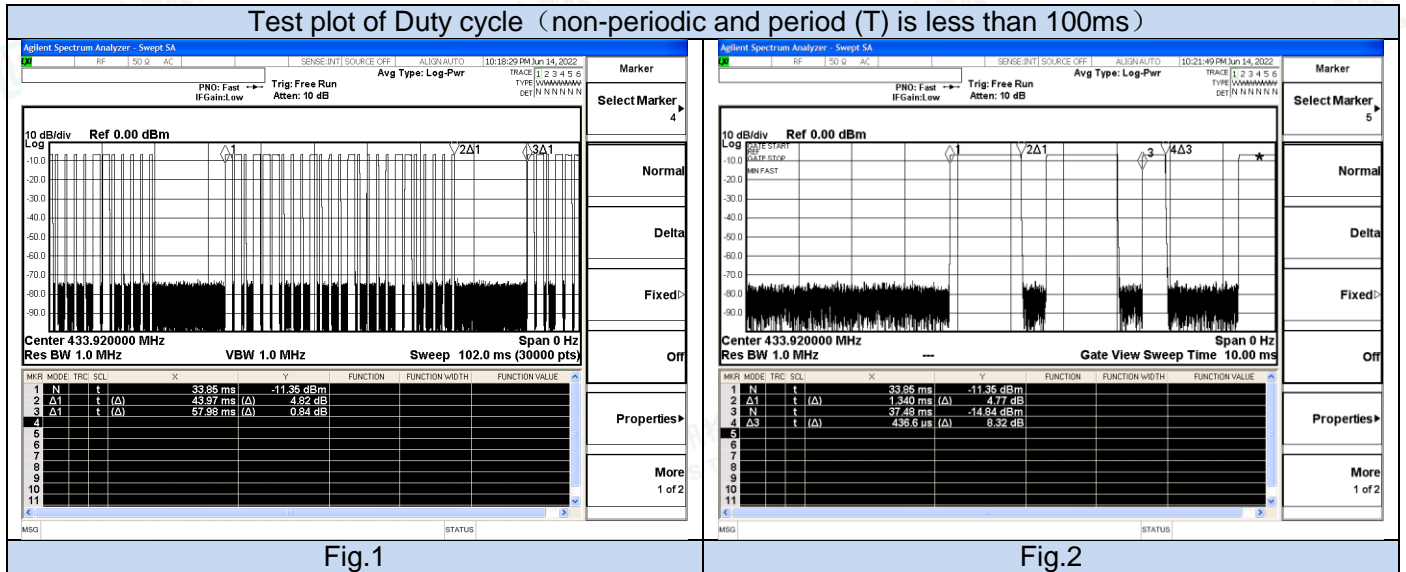

Fig.1

Fig.2





### 5.5. Power line conducted emissions

#### 5.5.1 Standard Applicable

According to §15.207 (a): For an intentional radiator which is designed to be connected to the public utility (AC) power line, the radio frequency voltage that is conducted back onto the AC power line on any frequency or frequencies within the band 150 kHz to 30 MHz shall not exceed 250 microvolts (The limit decreases linearly with the logarithm of the frequency in the range 0.15 MHz to 0.50 MHz). The limits at specific frequency range is listed as follows:

Frequency Range (MHz)	Limits (dB $\mu$ V)	
	Quasi-peak	Average
0.15 to 0.50	66 to 56	56 to 46
0.50 to 5	56	46
5 to 30	60	50

#### 5.5.2 Block Diagram of Test Setup

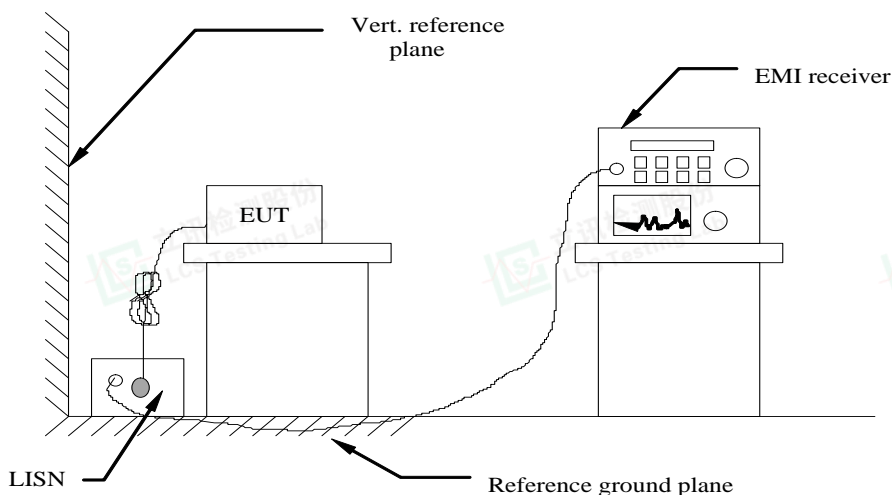

#### 5.5.3 Test Results

**Not applicable.**





## 5.6. Antenna Requirement

### FCC 15.203

#### 5.6.1. Standard Applicable

An intentional radiator shall be designed to ensure that no antenna other than that furnished by the responsible party shall be used with the device. The use of a permanently attached antenna or of an antenna that uses a unique coupling to the intentional radiator shall be considered sufficient to comply with the provisions of this section.

This EUT uses an integral antenna which is permanently attached.

#### 5.6.2. Result

Compliant.

The antenna used for transmitting is permanently attached and no consideration of replacement. Please see EUT photo for details.



Shenzhen LCS Compliance Testing Laboratory Ltd.

Add: 101, 201 Bldg A & 301 Bldg C, Juji Industrial Park Yabianxueziwei, Shajing Street, Baoan District, Shenzhen, 518000, China

Tel: +(86) 0755-82591330 | E-mail: webmaster@lcs-cert.com | Web: www.lcs-cert.com

Scan code to check authenticity



## 6. LIST OF MEASURING EQUIPMENTS

Item	Equipment	Manufacturer	Model No.	Serial No.	Cal Date	Due Date
1	MXA Signal Analyzer	Agilent	N9020A	MY49100060	2021-11-16	2022-11-15
2	DC Power Supply	Agilent	E3642A	N/A	2021-11-25	2022-11-24
3	Temperature & Humidity Chamber	GUANGZHOU GOGNWEN	GDS-100	70932	2021-10-07	2022-10-06
4	EMI Test Software	Farad	EZ	/	N/A	N/A
5	3m Full Anechoic Chamber	MRDIANZI	FAC-3M	MR009	2021-09-25	2022-09-24
6	Positioning Controller	MF	MF7082	MF78020803	2021-06-21	2022-06-20
7	Active Loop Antenna	SCHWARZBECK	FMZB 1519B	00005	2021-07-25	2024-07-24
8	By-log Antenna	SCHWARZBECK	VULB9163	9163-470	2021-07-25	2024-07-24
9	Horn Antenna	SCHWARZBECK	BBHA 9120D	9120D-1925	2021-07-01	2024-06-30
10	EMI Test Receiver	R&S	ESR 7	101181	2021-06-21	2022-06-20
11	RS SPECTRUM ANALYZER	R&S	FSP40	100503	2021-11-16	2022-11-15
12	Broadband Preamplifier	/	BP-01M18G	P190501	2021-06-21	2022-06-20
13	EMI Test Receiver	R&S	ESPI	101840	2021-06-21	2022-06-20
14	Artificial Mains	R&S	ENV216	101288	2021-06-21	2022-06-20
15	10dB Attenuator	SCHWARZBECK	MTS-IMP-136	261115-001-0032	2021-06-21	2022-06-20



Shenzhen LCS Compliance Testing Laboratory Ltd.

Add: 101, 201 Bldg A & 301 Bldg C, Juji Industrial Park Yabianxueziwei, Shajing Street, Baoan District, Shenzhen, 518000, China

Tel: +(86) 0755-82591330 | E-mail: webmaster@lcs-cert.com | Web: www.lcs-cert.com

Scan code to check authenticity



## 7. TEST SETUP PHOTOGRAPHS

Please refer to separated files for External Photos of the EUT.

## 8. EXTERIOR PHOTOGRAPHS OF THE EUT

Please refer to separated files for External Photos of the EUT.

## 9. INTERIOR PHOTOGRAPHS OF THE EUT

Please refer to separated files for Internal Photos of the EUT.

-----THE END OF TEST REPORT-----

