



FCC Part 15, Subpart C Test Report

FCC ID: 2A3JH-PC345A-1

Applicant: Dongguan Yuzhenrong Trading Co., Ltd

Address: Room 204, No.74, Humen Xinlian 9th Street, Humen Village, Humen Town, Dongguan City, Guangdong

Product: Wireless Mouse and keyboard set

Brand: N/A

Test Model(s): PC345A-1

Series Model(s): PC345B, PC345C, PC345D, PC345E, PC345A-1, PC345B-1, PC345C-1, PC345D-1, PC345E-1, CK200G, CM668G

Test Date: Oct. 10, 2021 ~ Mar. 31, 2022

Issued Date: Mar. 31, 2022

Issued By: Hwa-Hsing (Dongguan) Testing Co., Ltd.

Address: No.101, Bld N1, Yuyuan 2Rd, Yuyuan Industrial Park, HuangJiang Town, Dongguan, China

Test Firm Registration No.: 915896

Standards: 47 CFR FCC Part 15, Subpart C (Section 15.247)
ANSI C63.10:2013

The above equipment has been tested by **Hwa-Hsing (Dongguan) Testing Co., Ltd.**, and found compliance with the requirement of the above standards. The test record, data evaluation & Equipment Under Test (EUT) configurations represented herein are true and accurate accounts of the measurements of the sample's EMC characteristics under the conditions specified in this report.

Prepared by :

Candy Zhang/ Report Engineer

Reviewed by :

Tank tan/ Project Engineer

Approved by :

Harry Li/ Technical Director

This report is for your exclusive use. Any copying or replication of this report to or for any other person or entity, or use of our name or trademark, is permitted only with our prior written permission. This report sets forth our findings solely with respect to the test samples identified herein. The results set forth in this report are not indicative or representative of the quality or characteristics of the lot from which a test sample was taken or any similar or identical product unless specifically and expressly noted. Our report includes all of the tests requested by you and the results thereof based upon the information that you provided to us. You have 60 days from date of issuance of this report to notify us of any material error or omission caused by our negligence, provided, however, that such notice shall be in writing and shall specifically address the issue you wish to raise. A failure to raise such issue within the prescribed time shall constitute your unqualified acceptance of the completeness of this report, the tests conducted and the correctness of the report contents. Unless specific mention, the uncertainty of measurement has been explicitly taken into the account to declare the compliance or non-compliance to the specification. The report must not be used by the client to claim product certification, approval, or endorsement by A2LA or any agency of the federal government. The report must not be used by the client to claim product certification, approval, or endorsement by TAF or any government agencies.



Table of Contents

Release Control Record	4
1 Summary of Test Results	5
1.1 Measurement Uncertainty.....	5
1.2 Modification Record	5
2 General Information	6
2.1 General Description of EUT	6
2.2 Description of Test Modes.....	7
2.2.1 Test Mode Applicability and Tested Channel Detail	8
2.3 Description of Support Units	9
2.3.1 Configuration of System under Test	9
3 Test Types and Results	10
3.1 Radiated Emission and Band-edge Measurement	10
3.1.1 Limits of Radiated Emission and Band-edge Measurement	10
3.1.2 Test Instruments	11
3.1.3 Test Procedures.....	12
3.1.4 Deviation from Test Standard	13
3.1.5 Test Setup.....	14
3.1.6 EUT Operating Conditions.....	15
3.1.7 Test Results	16
3.2 Number of Hopping Frequency Used	23
3.2.1 Limits of Hopping Frequency Used Measurement	23
3.2.2 Test Setup.....	23
3.2.3 Test Instruments	23
3.2.4 Test Procedure	23
3.2.5 Deviation from Test Standard	23
3.2.6 Test Results	24
3.3 Dwell Time on Each Channel.....	25
3.3.1 Limits of Dwell Time on Each Channel Measurement.....	25
3.3.2 Test Setup.....	25
3.3.3 Test Instruments	25
3.3.4 Test Procedures.....	25
3.3.5 Deviation from Test Standard	25
3.3.6 Test Results	26
3.4 Channel Bandwidth.....	27
3.4.1 Limits of Channel Bandwidth Measurement.....	27
3.4.2 Test Setup.....	27
3.4.3 Test Instruments	27
3.4.4 Test Procedure	27
3.4.5 Deviation from Test Standard	27
3.4.6 EUT Operating Condition	27
3.4.7 Test Results	28
3.5 Occupied Bandwidth Measurement.....	30
3.5.1 Test Setup.....	30
3.5.2 Test Instruments	30
3.5.3 Test Procedure	30
3.5.4 Deviation from Test Standard	30
3.5.5 EUT Operating Conditions.....	30
3.5.6 Test Results	31
3.6 Hopping Channel Separation.....	33



3.6.1	Limits of Hopping Channel Separation Measurement.....	33
3.6.2	Test Setup.....	33
3.6.3	Test Instruments	33
3.6.4	Test Procedure	33
3.6.5	Deviation from Test Standard	33
3.6.6	Test Results	34
3.7	Maximum Output Power	36
3.7.1	Limits of Maximum Output Power Measurement	36
3.7.2	Test Setup.....	36
3.7.3	Test Instruments	36
3.7.4	Test Procedure	36
3.7.5	Deviation fromTest Standard	37
3.7.6	EUT Operating Condition	37
3.7.7	Test Results	37
3.8	Conducted Out of Band Emission Measurement	39
3.8.1	Limits of Conducted Out of Band Emission Measurement.....	39
3.8.2	Tets Setup.....	39
3.8.3	Test Instruments	39
3.8.4	Test Procedure	39
3.8.5	Deviation from Test Standard	39
3.8.6	EUT Operating Condition	39
3.8.7	Test Results	40
4	Pictures of Test Arrangements.....	43
5	Test Instruments	44
	Appendix – Information on the Testing Laboratories	45



Release Control Record

Issue No.	Description	Date Issued
210923VL02-RF-US-01	Original Release	Mar. 31, 2022



1 Summary of Test Results

47 CFR FCC Part 15, Subpart C (Section 15.247) KDB 558074 D01 15.247 Meas Guidance v05r02 ANSI C63.10:2013;			
Clause	Test Item	Result	Remarks
15.247(a)(1) (iii)	Number of Hopping Frequency Used	Pass	Meet the requirement of limit.
15.247(a)(1) (iii)	Dwell Time on Each Channel	Pass	Meet the requirement of limit.
15.247(a)(1)	1. Hopping Channel Separation 2. Spectrum Bandwidth of a Frequency Hopping Sequence Spread Spectrum System	Pass	Meet the requirement of limit.
15.247(b)	Maximum Peak Output Power	Pass	Meet the requirement of limit.
---	Occupied Bandwidth Measurement	Pass	Reference only
15.205 & 209	Radiated Emissions	Pass	Meet the requirement of limit.
15.247(d)	Band Edge Measurement	Pass	Meet the requirement of limit.
15.247(d)	Antenna Port Emission	Pass	Meet the requirement of limit.
15.203	Antenna Requirement	Pass	No antenna connector is used.

Note1: If the Frequency Hopping System operating in 2400-2483.5MHz band and the output power less than 125mW. The hopping channel carrier frequencies separated by a minimum of 25kHz or two-thirds of the 20dB bandwidth of hopping channel whichever is greater.

Note2: The EUT has been verified to comply with the requirements of FCC Part 15, Subpart B, Class B (sDoC). The test report has been issued separately.

1.1 Measurement Uncertainty

Where relevant, the following measurement uncertainty levels have been estimated for tests performed on the EUTs specified in CISPR 16-4-2:

The listed uncertainties are the worst-case uncertainty for the entire range of measurement. Please note that the uncertainty values are provided for informational purposes only and are not used in determining the PASS/FAIL results.

Measurement	Frequency	Expanded Uncertainty (k=2) (±)
Conducted Emissions at mains ports	150kHz ~ 30MHz	2.66 dB
Radiated Emissions up to 1 GHz	9KHz ~ 30MHz	2.16 dB
	30MHz ~ 1000MHz	3.47 dB
Radiated Emissions above 1 GHz	1GHz ~ 18GHz	4.84 dB
	18GHz ~ 40GHz	4.67 dB

Note: This uncertainty represents an expanded uncertainty expressed at approximately the 95% confidence level using a coverage factor of k = 2.

1.2 Modification Record

There were no modifications required for compliance.



2 General Information

2.1 General Description of EUT

Product	Wireless Mouse and keyboard set
Brand	N/A
Test Model(s)	PC345A-1
Series Model(s)	PC345B, PC345C, PC345D, PC345E, PC345A-1, PC345B-1, PC345C-1, PC345D-1, PC345E-1, CK200G, CM668G
Status of EUT	Engineering prototype
Power Supply Rating	DC1.5V*2(AAA) battery
Modulation Type	GFSK
Operating Frequency	2408 ~ 2474MHz
Number of Channel	34
Output Power	-8.60dBm
Antenna Type	PCB Antenna
Antenna Gain	-0.61dBi Maximum peak Gain
Antenna Connector	N/A
Accessory Device	N/A
Cable Supplied	N/A

Note:

1. Please refer to the EUT photo document (Reference No.:210923KH02-1&-2) for detailed product photo.
2. The above EUT information is declared by manufacturer and for more detailed features description, please refer to the manufacturer's specifications or User's Manual.



2.2 Description of Test Modes

34 channels are provided to this EUT:

Channel	Freq. (MHz)	Channel	Freq. (MHz)	Channel	Freq. (MHz)	Channel	Freq. (MHz)
0	2408	9	2426	18	2444	27	2462
1	2410	10	2428	19	2446	28	2464
2	2412	11	2430	20	2448	29	2466
3	2414	12	2432	21	2450	30	2468
4	2416	13	2434	22	2452	31	2470
5	2418	14	2436	23	2454	32	2472
6	2420	15	2438	24	2456	33	2474
7	2422	16	2440	25	2458		
8	2424	17	2442	26	2460		



2.2.1 Test Mode Applicability and Tested Channel Detail

EUT Configure Mode	Applicable test items	X-Axis	Y-Axis	Z-Axis	Voltage Supply
Conducted	AC Power Conducted Emission	N/A	N/A	N/A	DC3.0V
Radiated	Radiated Emissions	√	√	√	
Antenna Port Conducted Measurement	Number of Hopping Frequency Used	N/A	N/A	N/A	
	Dwell Time on Each Channel	N/A	N/A	N/A	
	Band Edge Measurement	N/A	N/A	N/A	
	Antenna Port Emission	N/A	N/A	N/A	
	Conducted power	N/A	N/A	N/A	
	Hopping Channel Separation	N/A	N/A	N/A	
	Spectrum Bandwidth of a Frequency Hopping Sequence Spread Spectrum System	N/A	N/A	N/A	

- *: The EUT had been pre-tested on the positioned of each 3 Axis. The worst case was found when positioned on **Z-plane**.
- “N/A” means no effect.

Test Condition:

Applicable test items	Environmental Conditions	Tested by
AC Power Conducted Emission	25deg. C, 65%RH	Jim Xu
Radiated Emissions	25deg. C, 65%RH	Jim Xu
Antenna Port Conducted Measurement	25deg. C, 65%RH	Dragonlong

- Pre-Scan has been conducted to determine the worst-case mode from all possible combinations between available modulations, data rates and antenna ports (if EUT with antenna diversity architecture). Following channel(s) was (were) selected for the final test as listed below.

Radiated Emission Test (Above 1 GHz):

EUT Configure Mode	Available Channel	Tested Channel	Modulation Technology	Modulation Type	Packet Type
-	0 to 33	0, 16, 33	FHSS	GFSK	1Mbps

Radiated Emission Test (Below 1 GHz):

EUT Configure Mode	Available Channel	Tested Channel	Modulation Technology	Modulation Type	Packet Type
-	0 to 33	0	FHSS	GFSK	1Mbps



Power Line Conducted Emission Test:

EUT Configure Mode	Available Channel	Tested Channel	Modulation Technology	Modulation Type	Packet Type
-	0 to 33	0	FHSS	GFSK	1Mbps

Antenna Port Conducted Measurement:

This item includes all test value of each mode, but only includes spectrum plot of worst value of each mode.

EUT Configure Mode	Available Channel	Tested Channel	Modulation Technology	Modulation Type	Packet Type
-	0 to 33	0, 16, 33	FHSS	GFSK	1Mbps

2.3 Description of Support Units

The EUT has been tested as an independent unit together with other necessary accessories or support units. The following support units or accessories were used to form a representative test configuration during the tests.

No.	Product	Brand	Model No.	Serial No.	FCC ID
1.	Notebook	Lenovo	ThinkPad X280	SL10P97665	N/A

No.	Signal Cable Description of The Above Support Units
1.	USB serial cable Un-shieldin1m

2.3.1 Configuration of System under Test

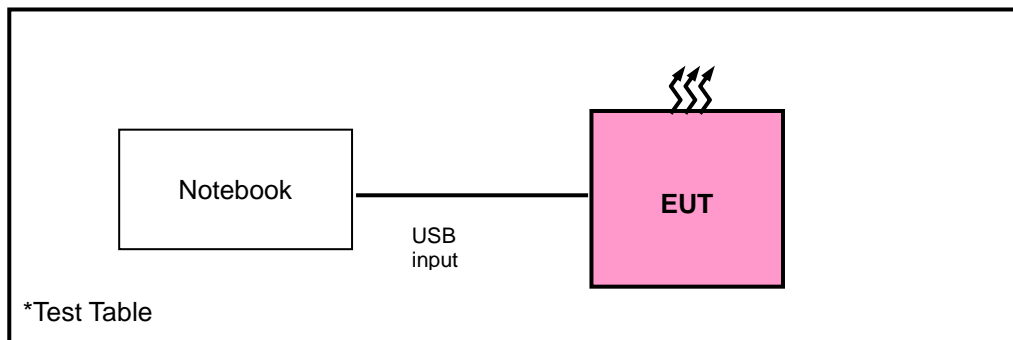



3 Test Types and Results

3.1 Radiated Emission and Band-edge Measurement

3.1.1 Limits of Radiated Emission and Band-edge Measurement

Radiated emissions which fall in the restricted bands must comply with the radiated emission limits specified as below table. Other emissions shall be at least 20 dB below the highest level of the desired power:

Frequencies (MHz)	Field Strength (microvolts/meter)	Measurement Distance (meters)
0.009 ~ 0.490	2400/F(kHz)	300
0.490 ~ 1.705	24000/F(kHz)	30
1.705 ~ 30.0	30	30
30 ~ 88	100	3
88 ~ 216	150	3
216 ~ 960	200	3
Above 960	500	3

* DTS emissions in non-restricted frequency bands Subclause 11.11 of ANSI C63.10 is applicable.

* DTS emissions in restricted frequency bands Subclause 11.12 of ANSI C63.10 is applicable

Note:

1. The lower limit shall apply at the transition frequencies.
2. Emission level (dBuV/m) = 20 log Emission level (uV/m).
3. For frequencies above 1000 MHz, the field strength limits are based on average detector, however, the peak field strength of any emission shall not exceed the maximum permitted average limits, specified above by more than 20 dB under any condition of modulation.



3.1.2 Test Instruments

Radiated emission below 30MHz:

Equipment	Manufacturer	Model No.	Serial No.	Next Cal.
EMI Test Receiver	Rohde&Schwarz	ESR 7	101961	2022/01/13
EMI Test Receiver	Rohde&Schwarz	ESR 7	101961	2023/01/12
3m Semi-anechoic Chamber	MAORUI	9m*6m*6m	NSEMC003	2022/04/14
Test software	FARAD	FARAD	EZ_EMCV1.1.4.2	N/A
Loop Antenna	EMCI	HLA 6121	45745	2022/04/13
Preamplifier	EMCI	EMC001340	980201	2022/09/12
Antenna Tower	MF	MFA-440H	NA	NA
Turn Table	MF	MFT-201SS	NA	NA
Antenna Tower&Turn Table Controller	MF	MF-7802	NA	NA

Frequency Range below 1GHz:

Equipment	Manufacturer	Model No.	Serial No.	Next Cal.
EMI Test Receiver	Rohde&Schwarz	ESR 7	101961	2022/01/13
EMI Test Receiver	Rohde&Schwarz	ESR 7	101961	2023/01/12
Broadband antenna	Schwarzbeck	VULB 9168	00937	2022/04/15
3m Semi-anechoic Chamber	MAORUI	9m*6m*6m	NSEMC003	2022/04/14
Signal Amplifier	Com-power	PAM-103	18020051	2022/09/07
Attenuator	Rohde&Schwarz	TS2GA-6dB	18101101	N/A
Test software	FARAD	FARAD	EZ_EMCV1.1.4.2	N/A

Frequency Range 1-18GHz:

Equipment	Manufacturer	Model No.	Serial No.	Next Cal.
3m Semi-anechoic Chamber	MAORUI	9m*6m*6m	NSEMC003	2022/04/14
Horn Antenna	Schwarzbeck	BBHA 9170	01959	2022/04/15
Broadband Coaxial Preamplifier	Schwarzbeck	BBV 9718	00025	2022/04/14
Spectrum	Keysight	N9020A	MY51240612	2022/09/12
Antenna Tower	MF	MFA-440H	NA	NA
Turn Table	MF	MFT-201SS	NA	NA
Antenna Tower&Turn Table Controller	MF	MF-7802	NA	NA

Frequency Range 18-40GHz:

Equipment	Manufacturer	Model No.	Serial No.	Next Cal.
3m Semi-anechoic Chamber	MAORUI	9m*6m*6m	NSEMC003	2022/04/14
Spectrum Analyzer	Rohde&Schwarz	FSV-40N	101783	2022/01/13
Spectrum Analyzer	Rohde&Schwarz	FSV-40N	101783	2023/01/12
Horn Antenna	Schwarzbeck	BBHA 9170	BBHA9170242	2022/04/15
Pre-Amplifier	EMCI	EMC 184045SE	9870709	2022/01/13
Pre-Amplifier	EMCI	EMC 184045SE	9870709	2023/01/12
Antenna Tower	MF	MFA-440H	NA	NA
Turn Table	MF	MFT-201SS	NA	NA
Antenna Tower&Turn Table Controller	MF	MF-7802	NA	NA

- Note: 1. The calibration interval of the above test instruments is 12months (The Antenna and Chamber was 24 months) and the calibrations are traceable to CEPREI/CHINA.
 2. The test was performed in 966.



3.1.3 Test Procedures

a. **Peak emission levels are measured by setting the instrument as follow:**

1) RBW&VBWsettingas a function of frequency:

Frequency	RBW	VBW
9kHz~150kHz	200Hz	600Hz
0.15MHz~30MHz	9kHz	30kHz
30MHz~1000MHz	120kHz	300kHz
>1000MHz	1MHz	3MHz

- 2) Detector = peak.
- 3) Sweep time = auto.
- 4) Trace mode = max hold.
- 5) Allow sweeps to continue until the trace stabilizes. (Note that the required measurement time may be lengthened for low-duty-cycle applications.)

Note: If the peak-detected amplitude can be shown to comply with the average limit, then it is not necessary to perform a separate average measurement

b. **Average emission levels are measured by setting the instrument as follow:**

● **Trace averaging with continuous EUT transmission at full power**

If the EUT can be configured or modified to transmit continuously (D ≥ 98%), then the average emission levels shall be measured using the following method (with EUT transmitting continuously):

- 1) RBW=1 MHz (unless otherwise specified).
- 2) VBW ≥ 3 *RBW.
- 3) Detector =RMS
- 4) Sweep time = auto.
- 5) Perform a trace average of at least 100 traces.

● **Trace averaging across ON and OFF times of the EUT transmissions followed by duty cycle correction**

If continuous transmission of the EUT (D≥98%) cannot be achieved and the duty cycle is constant (duty cycle variations are less than ±2%). then the following procedure shall be used

- 1) The EUT shall be configured to operate at the maximum achievable duty cycle.
- 2) Measure the duty cycle D of the transmitter output signal as described in 11.6.
- 3) RBW=1 MHz (unless otherwise specified).
- 4) VBW ≥ 3 *RBW.
- 5) Detector =RMS
- 6) Sweep time = auto.
- 7) Perform a trace average of at least 100 traces.

A correction factor shall be added to the measurement results prior to comparing with the emission limit to compute the emission level that would have been measured had the test been performed at 100% duty cycle. The correction factor is computed as follows:

- *If power averaging (rms) mode was used in step 5). then the applicable correction factor is [10 10g (1/ D)], where D is the duty cycle.
- **If linear voltage averaging mode was used in step f). then the applicable correction factor is [20 10g (1/D)], where D is the duty cycle.
- ***If a specific emission is demonstrated to be continuous (D > 98%) rather than turning ON and OFF with the transmit cycle, then no duty cycle correction is required for that



● **Reduced VBW Averaging across ON and OFF times of the EUT transmissions with max hold**

If continuous transmission of the EUT ($D > 98\%$) cannot be achieved and the duty cycle is not constant (duty cycle variations exceed $\pm 2\%$), then the following procedure shall be used:

- 1) RBW = 1 MHz.
 - 2) $VBW \geq 1/T$.
 - 3) Detector = peak
 - 4) Sweep time = auto.
 - 5) Trace mode = max hold.
 - 6) Allow max hold to run for at least $[50 \times (1/D)]$ traces
- c. The EUT was placed on the top of a rotating table 0.8 meters (below 1GHz) / 1.5 meters (1-18GHz) / 1.5 meters (18-40GHz) above the reference ground. The table was rotated 360 degrees to determine the position of the highest radiation.
- d. The EUT was set 3 meters away from the interference-receiving antenna (Below 1GHz) & (Above 1-18GHz), which was mounted on the top of a variable-height antenna tower. The EUT was set 1 meters away from the interference-receiving antenna (18-40GHz).
- e. The height of antenna is varied from one meter to four meters above the ground to determine the maximum value of the field strength. Both horizontal and vertical polarizations of the antenna are set to make the measurement.
- f. For each suspected emission, the EUT was arranged to its worst case and then the antenna was tuned to heights from 1 meter to 4 meters and the rotatable table was turned from 0 degrees to 360 degrees to find the maximum reading.
- g. The test-receiver system was set to quasi-peak detect function and specified bandwidth with maximum hold mode when the test frequency is below 1 GHz.

The test-receiver system was set to peak and average detected function and specified bandwidth with maximum hold mode when the test frequency is above 1 GHz. If the peak reading value also meets average limit, measurement with the average detector is unnecessary.

Note:

1. Test procedures for measuring FHSS device: The use of a duty cycle correction factor (DCCF) is permitted for calculating average radiated field strength emission levels for an FHSS device in 15.247. This DCCF can be applied when the unwanted emission limit is subject to an average field strength limit (e.g., within a Government Restricted band) and the conditions specified in Section 15.35(c) can be satisfied. The average radiated field strength is calculated by subtracting the DCCF from the maximum radiated field strength level as determined through measurement. The maximum radiated field strength level represents the worst-case (maximum amplitude) RMS measurement of the emission(s) during continuous transmission (i.e., not including any time intervals during which the transmitter is off or is transmitting at a reduced power level). It is also acceptable to apply the DCCF to a measurement performed with a peak detector instead of the specified RMS power averaging detector. Note that Section 15.35(c) specifies that the DCCF shall represent the worst-case (greatest duty cycle) over any 100 msec transmission period. Subclause 7.5 of ANSI C63.10 provides additional measurement guidance applicable to determination of the DCCF.
2. All modes of operation were investigated and the worst-case emissions are reported.

3.1.4 Deviation from Test Standard

No deviation.



3.1.5 Test Setup

Radiated emission below 30MHz:

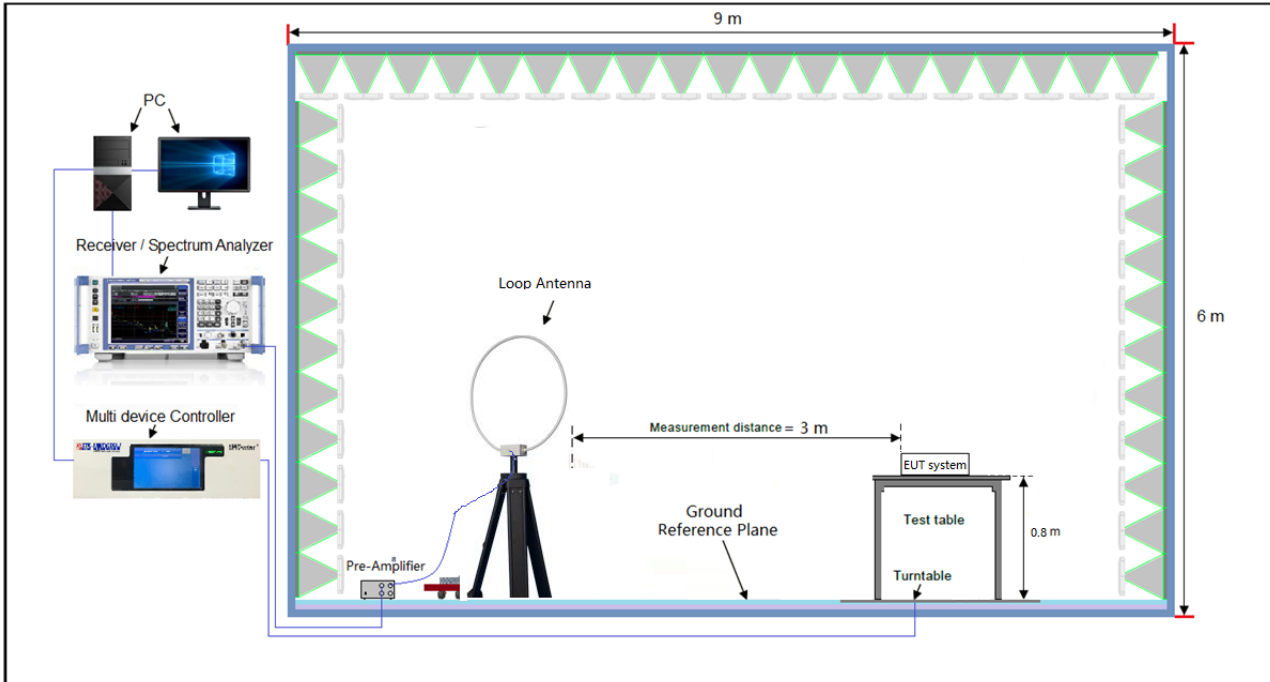

Frequency Range below 1GHz:

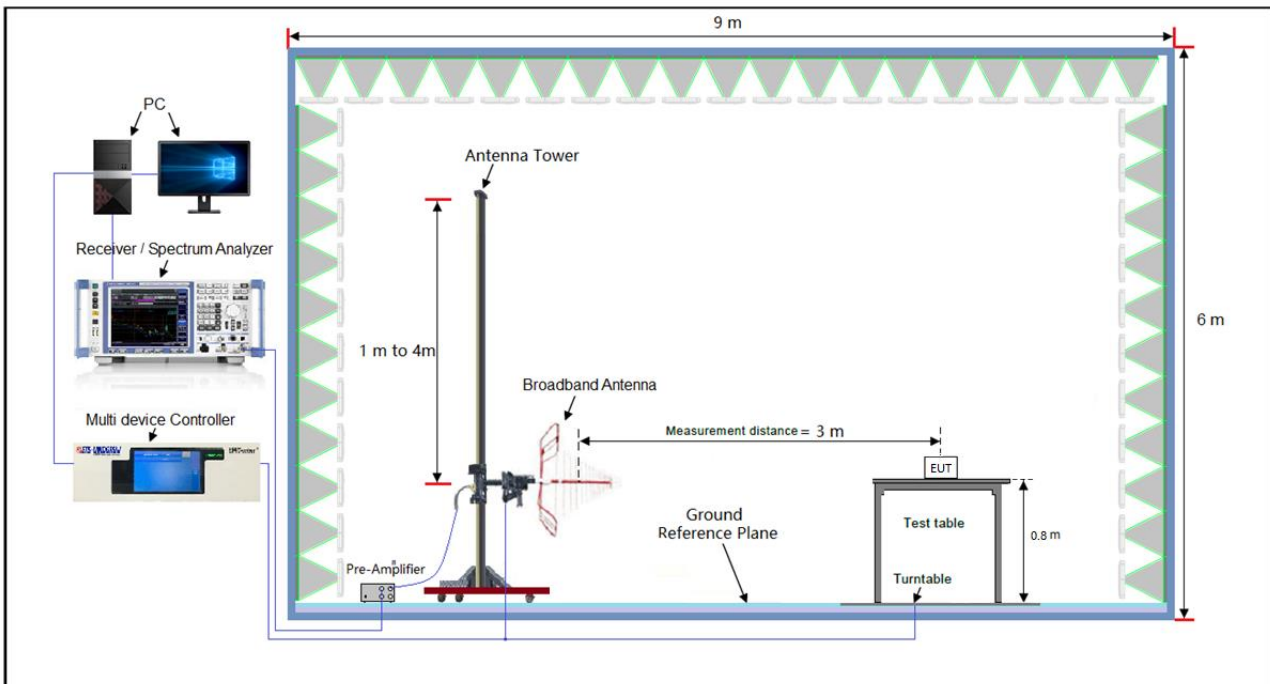



Frequency Range above 1GHz:

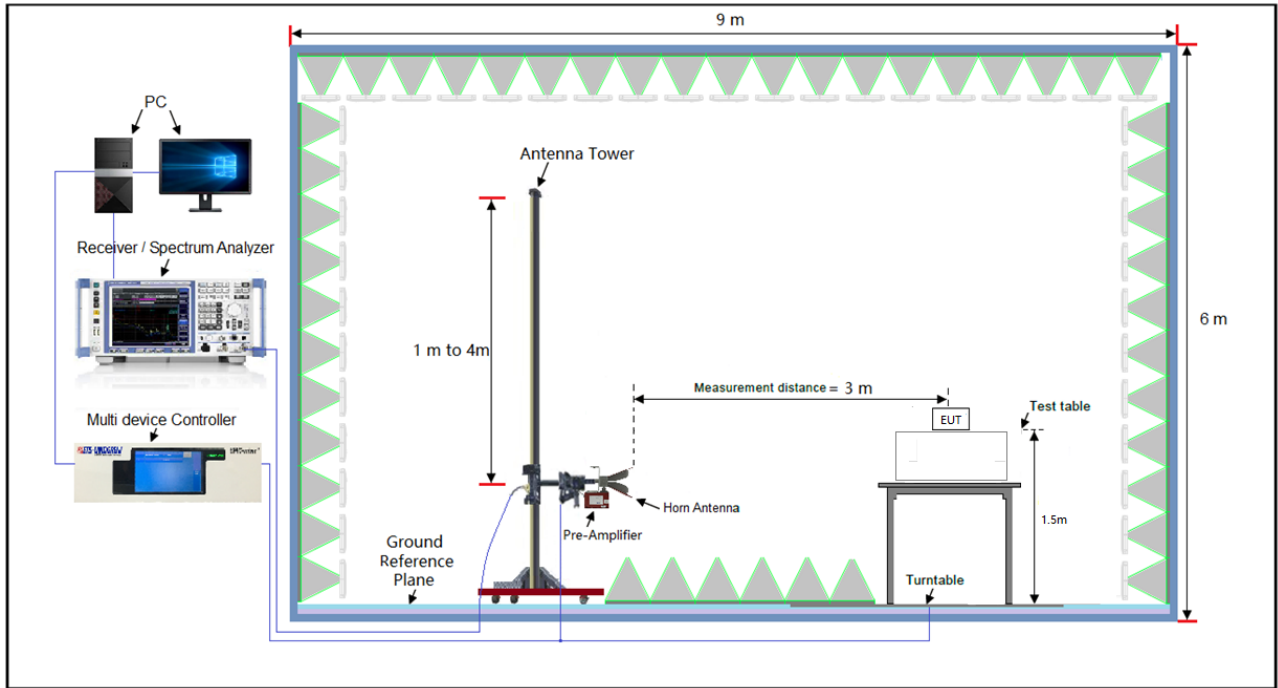

Frequency Range 18-40GHz:

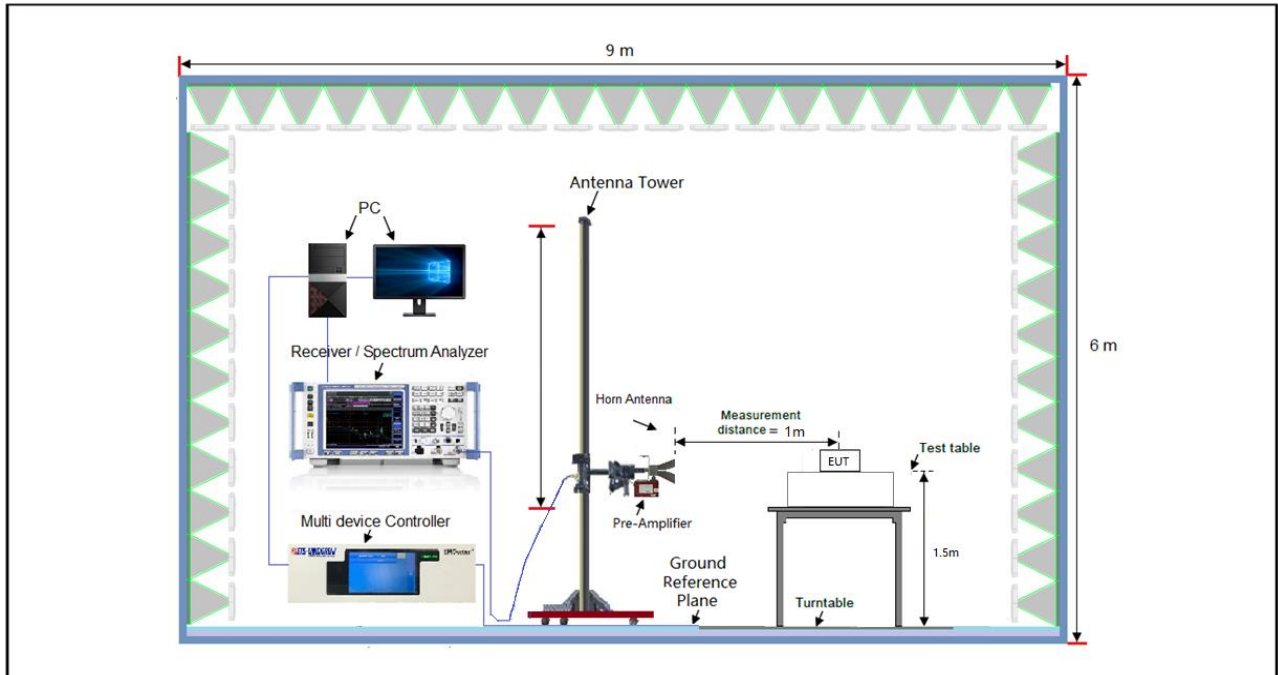

*For the actual test configuration, please refer to the attached file (Test Setup Photo).

3.1.6 EUT Operating Conditions

Set the EUT under transmission condition continuously at specific channel frequency.



3.1.7 Test Results

9 kHz ~ 30 MHz Data:

The amplitude of spurious emissions attenuated more than 20 dB below the permissible value is not required to be report.

30 MHz ~ 1GHz Worst-Case Data:

Test Channel	Channel 0	Frequency Range	30MHz ~ 1GHz
Detector Function	Peak (PK) Quasi-peak (QP)	Tested By	Jim Xu

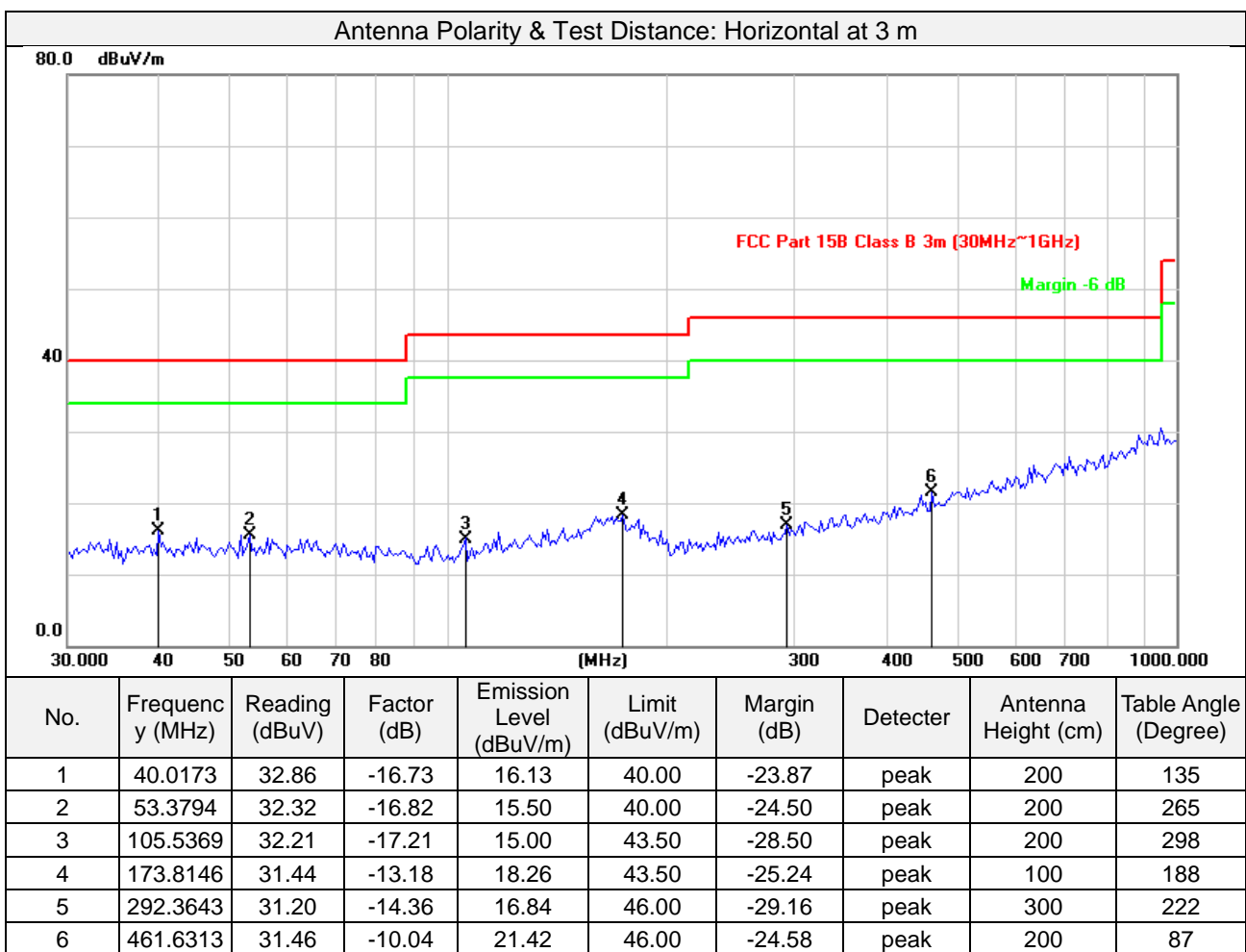

Remarks:

- 1.Emission Level = Read Level + Factor (Antenna Factor + Cable Loss - Preamp Factor)
- 2.Margin value = Emission level – Limit value



Test Channel	Channel 0	Frequency Range	30MHz ~ 1GHz
Detector Function	Peak (PK) Quasi-peak (QP)	Tested By	Jim Xu

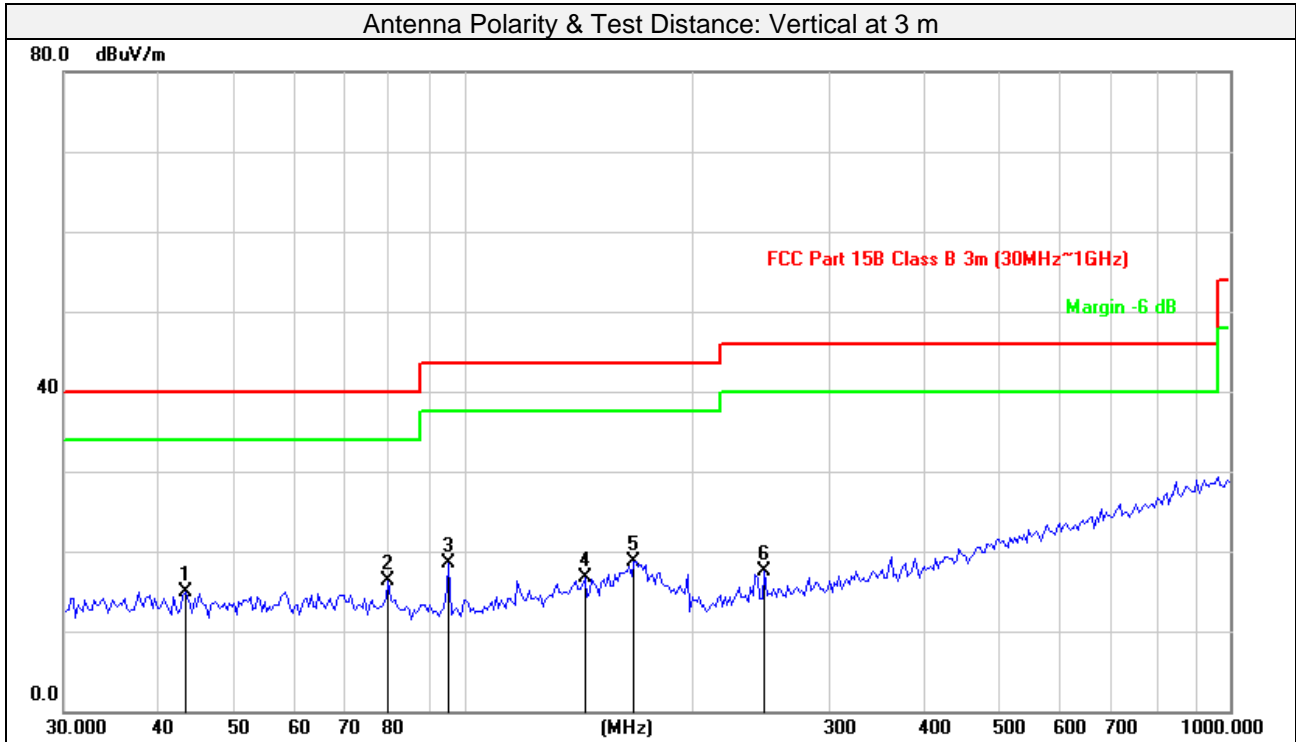

No.	Frequency (MHz)	Reading (dBuV)	Factor (dB)	Emission Level (dBuV/m)	Limit (dBuV/m)	Margin (dB)	Detector	Antenna Height (cm)	Table Angle (Degree)
1	43.2333	31.65	-16.74	14.91	40.00	-25.09	peak	100	165
2	79.6764	33.88	-17.65	16.23	40.00	-23.77	peak	100	198
3	95.6485	36.44	-17.89	18.55	43.50	-24.95	peak	100	245
4	143.7760	31.56	-14.86	16.70	43.50	-26.80	peak	200	298
5	166.6385	31.45	-12.77	18.68	43.50	-24.82	peak	200	277
6	246.9901	32.87	-15.33	17.54	46.00	-28.46	peak	100	48

Remarks:

1. Emission Level = Read Level + Factor (Antenna Factor + Cable Loss - Preamp Factor)
2. Margin value = Emission level – Limit value



Above 1GHz Data:

GFSK

Test Channel	Channel 0	Frequency Range	1GHz ~ 25GHz
Detector Function	Peak (PK) Average (AVG)	Tested By	Jim Xu

Antenna Polarity & Test Distance: Horizontal at 3 m

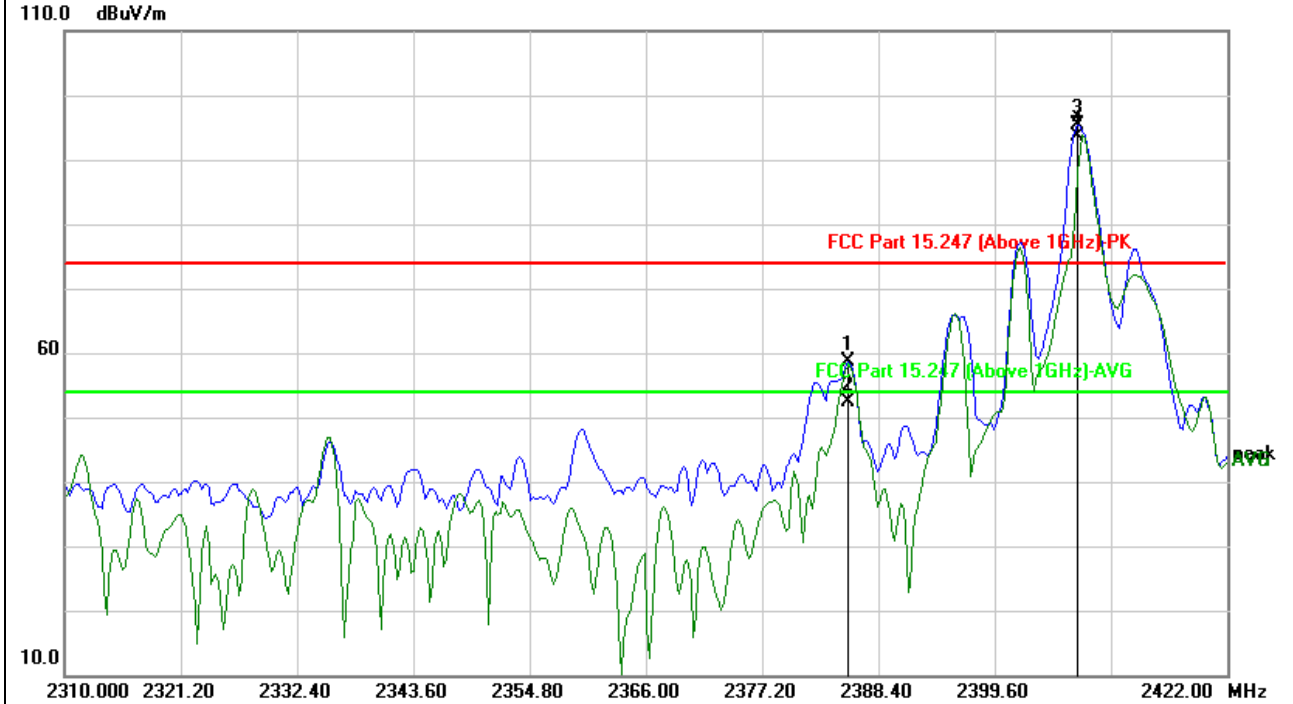

No.	Frequency (MHz)	Reading (dBuV)	Factor (dB)	Emission Level (dBuV/m)	Limit (dBuV/m)	Margin (dB)	Detector	Antenna Height (cm)	Table Angle (Degree)
1	2385.415	60.91	-2.40	58.51	74.00	-15.49	peak	218	111
2	2385.415	54.86	-2.40	52.46	54.00	-1.54	AVG	218	111
3 #	2407.635	97.64	-2.38	95.26			peak	218	111
4 #	2407.635	95.95	-2.38	93.57			AVG	218	111
5	4816.000	43.75	3.78	47.53	74.00	-26.47	peak	100	57
6	4816.000	41.06	3.78	44.84	54.00	-9.16	AVG	100	57
7	7224.000	47.41	8.16	55.57	74.00	-18.43	peak	100	175
8	7224.000	39.41	8.16	47.57	54.00	-6.43	AVG	100	175

Remarks:

- Emission Level = Read Level + Factor (Antenna Factor + Cable Loss - Preamp Factor)
Margin value = Emission level – Limit value
- #2408MHz: Fundamental frequency.



Test Channel	Channel 0	Frequency Range	1GHz ~ 25GHz
Detector Function	Peak (PK) Average (AVG)	Tested By	Jim Xu

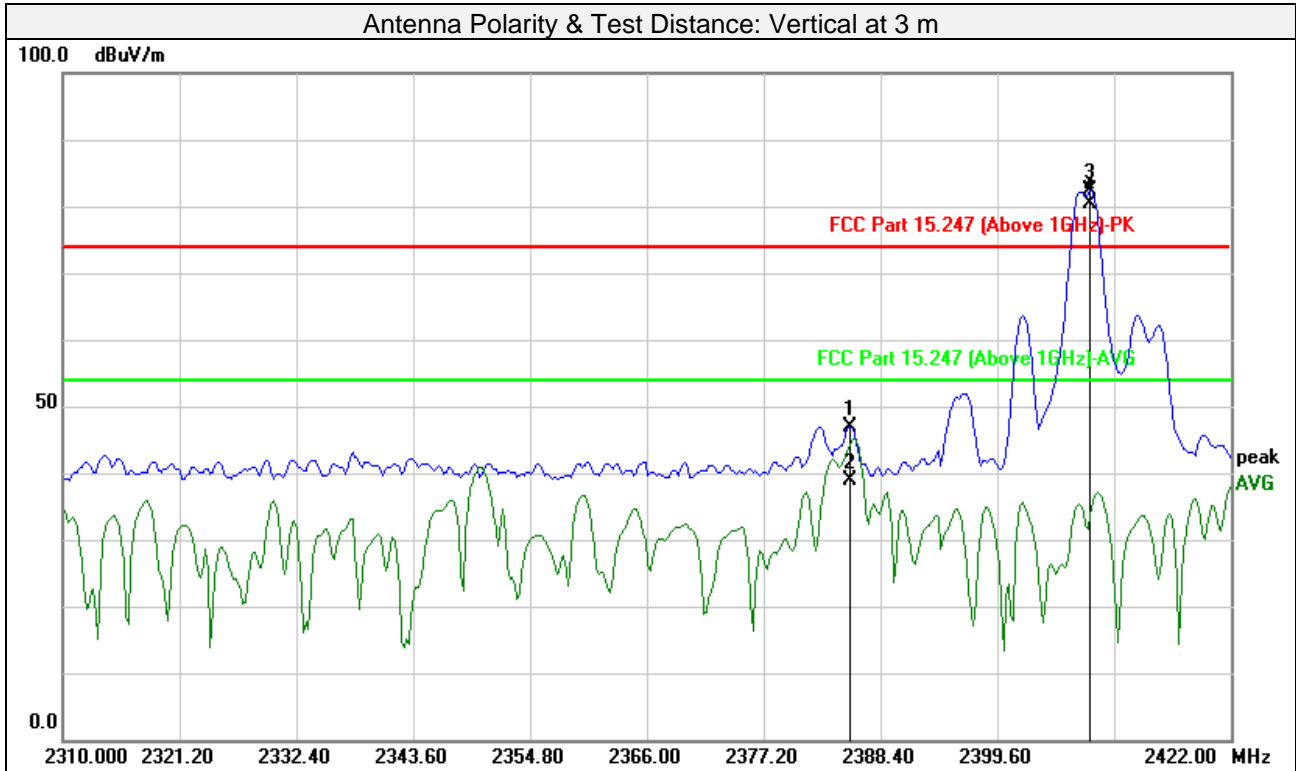

No.	Frequency (MHz)	Reading (dBuV)	Factor (dB)	Emission Level (dBuV/m)	Limit (dBuV/m)	Margin (dB)	Detector	Antenna Height (cm)	Table Angle (Degree)
1	2385.415	49.34	-2.40	46.94	74.00	-27.06	peak	100	347
2	2385.415	41.38	-2.40	38.98	54.00	-15.02	AVG	100	347
3 #	2408.533	84.73	-2.38	82.35			peak	100	347
4 #	2408.533	82.72	-2.38	80.34			AVG	100	347
5	4816.000	45.52	3.78	49.30	74.00	-24.70	peak	100	243
6	4816.000	36.15	3.78	39.93	54.00	-14.07	AVG	100	243
7	7224.000	45.94	8.16	54.10	74.00	-19.90	peak	100	120
8	7224.000	37.52	8.16	45.68	54.00	-8.32	AVG	100	120

Remarks:

1. Emission Level = Read Level + Factor (Antenna Factor + Cable Loss - Preamp Factor)

Margin value = Emission level – Limit value

2. #2408MHz: Fundamental frequency.



Test Channel	Channel 16	Frequency Range	1GHz ~ 25GHz
Detector Function	Peak (PK) Average (AVG)	Tested By	Jim Xu

Antenna Polarity & Test Distance: Horizontal at 3 m									
No.	Frequency (MHz)	Reading (dBuV)	Factor (dB)	Emission Level (dBuV/m)	Limit (dBuV/m)	Margin (dB)	Detector	Antenna Height (cm)	Table Angle (Degree)
1 #	2439.980	97.40	-2.35	95.05			peak	299	127
2 #	2439.980	96.18	-2.35	93.83			AVG	299	127
3	4880.000	49.03	3.97	53.00	74.00	-21.00	peak	100	152
4	4880.000	40.36	3.97	44.33	54.00	-9.67	AVG	100	152
5	7320.000	48.64	8.29	56.93	74.00	-17.07	peak	100	180
6	7320.000	41.61	8.29	49.90	54.00	-4.10	AVG	100	180

Antenna Polarity & Test Distance: Vertical at 3 m									
No.	Frequency (MHz)	Reading (dBuV)	Factor (dB)	Emission Level (dBuV/m)	Limit (dBuV/m)	Margin (dB)	Detector	Antenna Height (cm)	Table Angle (Degree)
1 #	2439.980	85.26	-2.35	82.91			peak	100	337
2 #	2439.980	82.55	-2.35	80.20			AVG	150	337
3	4880.000	45.26	3.97	49.23	74.00	-24.77	peak	100	254
4	4880.000	35.50	3.97	39.47	54.00	-14.53	AVG	100	254
5	7320.000	46.43	8.29	54.72	74.00	-19.28	peak	100	129
6	7320.000	36.49	8.29	44.78	54.00	-9.22	AVG	100	129

Remarks:

- 1. Emission Level = Read Level + Factor (Antenna Factor + Cable Loss - Preamp Factor)
Margin value = Emission level – Limit value
- 2. #2440MHz: Fundamental frequency.



Test Channel	Channel 33	Frequency Range	1GHz ~ 25GHz
Detector Function	Peak (PK) Average (AVG)	Tested By	Jim Xu

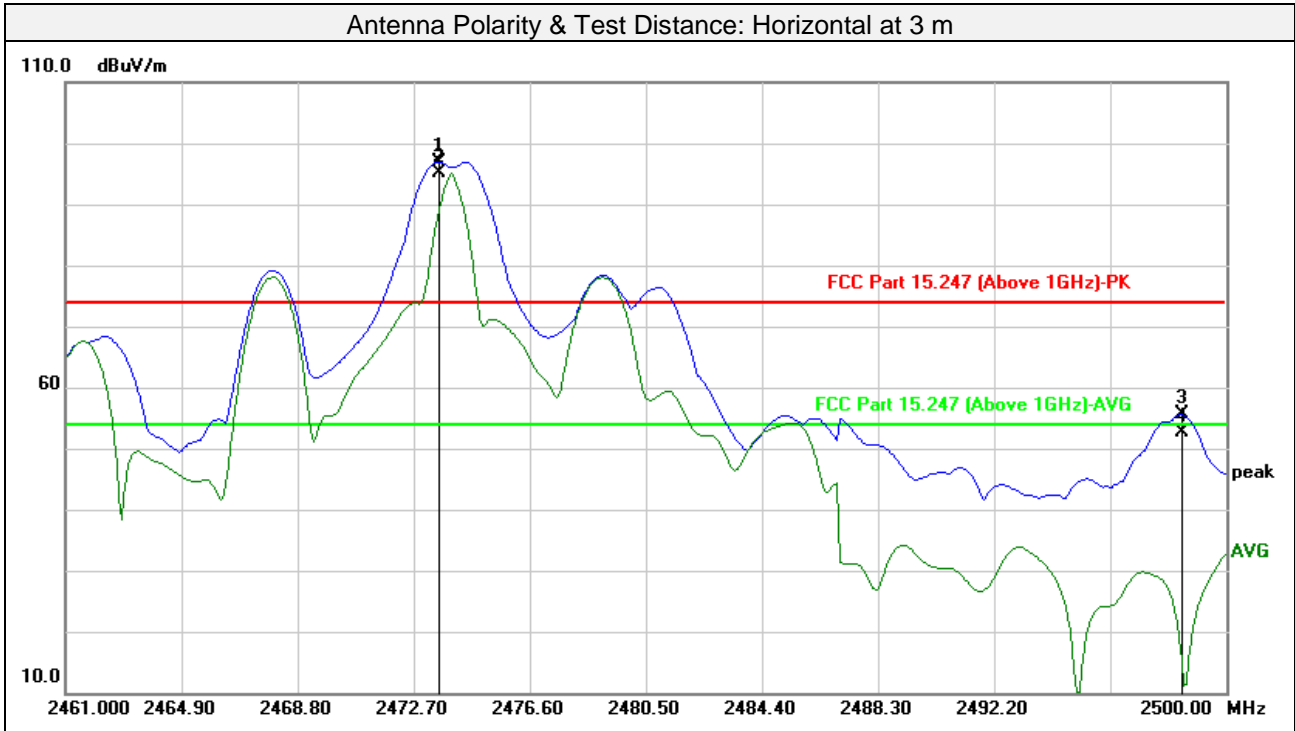

No.	Frequency (MHz)	Reading (dBuV)	Factor (dB)	Emission Level (dBuV/m)	Limit (dBuV/m)	Margin (dB)	Detector	Antenna Height (cm)	Table Angle (Degree)
1 #	2473.583	99.28	-2.29	96.99			peak	100	139
2 #	2473.583	97.51	-2.29	95.22			AVG	100	139
3	2498.515	57.80	-2.27	55.53	74.00	-18.47	peak	100	139
4	2498.515	54.79	-2.27	52.52	54.00	-1.48	AVG	100	139
5	4948.000	48.15	4.16	52.31	74.00	-21.69	peak	100	35
6	4948.000	39.67	4.16	43.83	54.00	-10.17	AVG	100	35
7	7422.000	51.44	8.40	59.84	74.00	-14.16	peak	100	186
8	7422.000	42.78	8.40	51.18	54.00	-2.82	AVG	100	186

Remarks:

- Emission Level = Read Level + Factor (Antenna Factor + Cable Loss - Preamp Factor)
Margin value = Emission level – Limit value
- #2474MHz: Fundamental frequency.



Test Channel	Channel 33	Frequency Range	1GHz ~ 25GHz
Detector Function	Peak (PK) Average (AVG)	Tested By	Jim Xu

Antenna Polarity & Test Distance: Vertical at 3 m

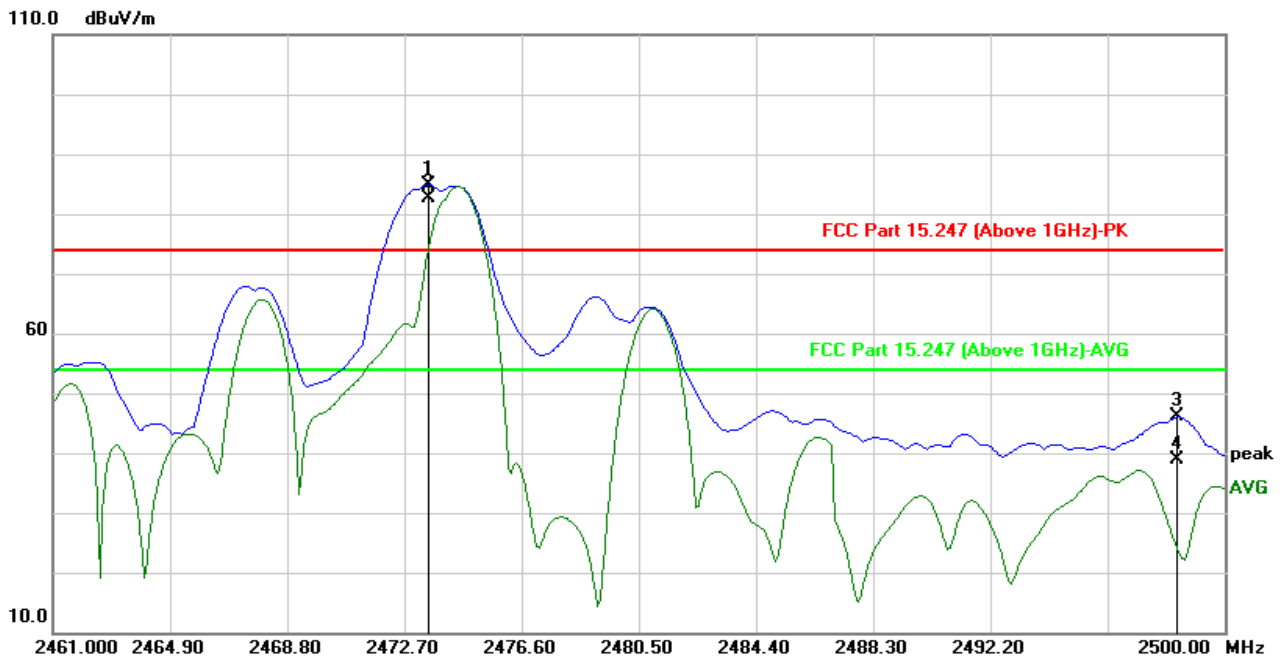

No.	Frequency (MHz)	Reading (dBuV)	Factor (dB)	Emission Level (dBuV/m)	Limit (dBuV/m)	Margin (dB)	Detector	Antenna Height (cm)	Table Angle (Degree)
1 #	2473.505	87.17	-2.29	84.88			peak	125	339
2 #	2473.505	85.04	-2.29	82.75			AVG	125	339
3	2498.437	48.30	-2.27	46.03	74.00	-27.97	peak	125	339
4	2498.437	41.10	-2.27	38.83	54.00	-15.17	AVG	125	339
5	4948.000	43.89	4.16	48.05	74.00	-25.95	peak	100	234
6	4948.000	34.03	4.16	38.19	54.00	-15.81	AVG	100	234
7	7422.000	45.53	8.40	53.93	74.00	-20.07	peak	100	129
8	7422.000	36.62	8.40	45.02	54.00	-8.98	AVG	100	129

Remarks:

1. Emission Level = Read Level + Factor (Antenna Factor + Cable Loss - Preamp Factor)
Margin value = Emission level – Limit value
2. #The 2474MHz: Fundamental frequency.



3.2 Number of Hopping Frequency Used

3.2.1 Limits of Hopping Frequency Used Measurement

At least 15 channels frequencies, and should be equally spaced.

3.2.2 Test Setup

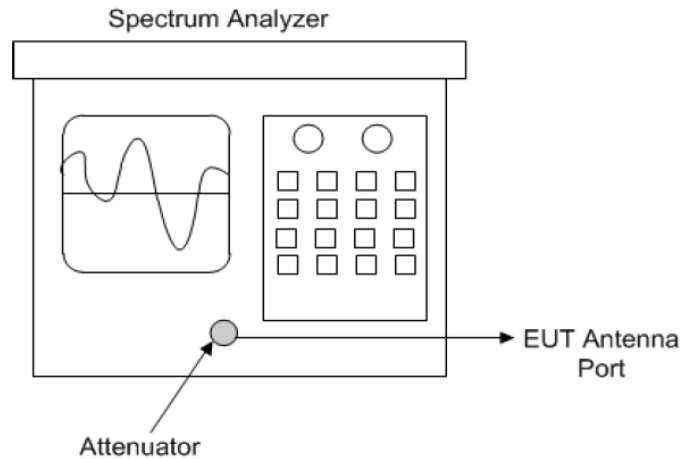

Spectrum analyzer test configuration

3.2.3 Test Instruments

Refer to section 5 to get information of above instrument.

3.2.4 Test Procedure

- Check the calibration of the measuring instrument (SA) using either an internal calibrator or a known signal from an external generator.
- Turn on the EUT and connect its antenna terminal to measurement via a low loss cable. Then set it to any one measured frequency within its operating range and make sure the instrument is operated in its linear range.
- Set the SA on MaxHold Mode, and then keep the EUT in hopping mode. Record all the signals from each channel until each one has been recorded.
- Set the SA on View mode and then plot the result on SA screen.
- Repeat above procedures until all frequencies measured were complete.

3.2.5 Deviation from Test Standard

No deviation.



3.2.6 Test Results

There are 34 hopping frequencies in the hopping mode. Please refer to next page for the test result. On the plots, it shows that the hopping frequencies are equally spaced.

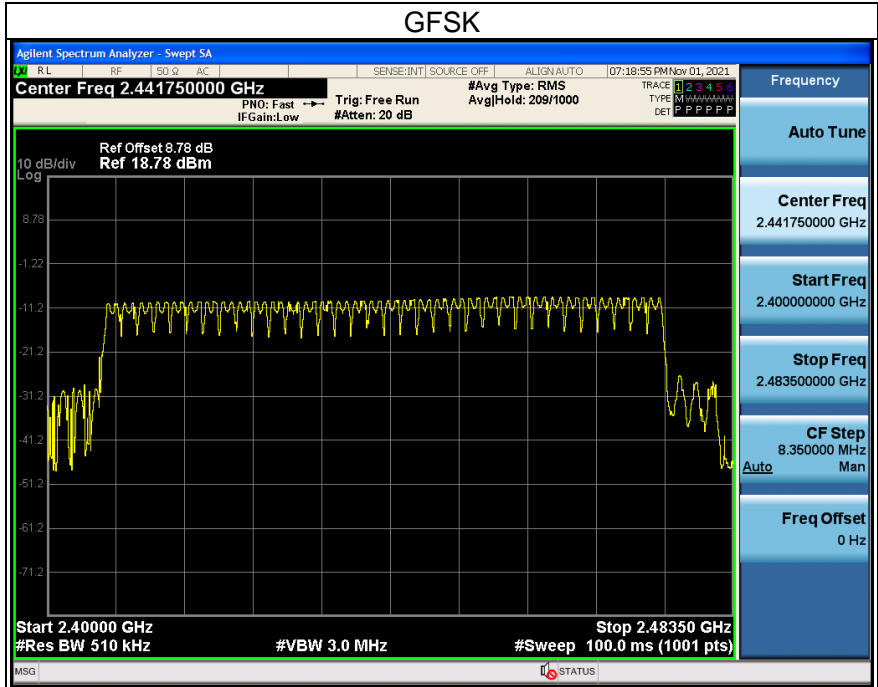



3.3 Dwell Time on Each Channel

3.3.1 Limits of Dwell Time on Each Channel Measurement

The average time of occupancy on any channel shall not be greater than 0.4 seconds within a period of 0.4 seconds multiplied by the number of hopping channels employed.

3.3.2 Test Setup

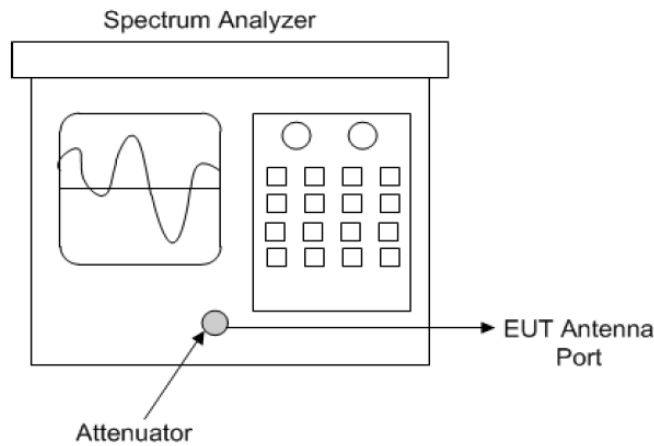

Spectrum analyzer test configuration

3.3.3 Test Instruments

Refer to section 5 to get information of above instrument.

3.3.4 Test Procedures

- Check the calibration of the measuring instrument (SA) using either an internal calibrator or a known signal from an external generator.
- Turn on the EUT and connect its antenna terminal to measurement via a low loss cable. Then set it to any one measured frequency within its operating range and make sure the instrument is operated in its linear range.
- Adjust the center frequency of SA on any frequency be measured and set SA to zero span mode. And then, set RBW and VBW of spectrum analyzer to proper value.
- Measure the time duration of one transmission on the measured frequency. And then plot the result with time difference of this time duration.
- Repeat above procedures until all different time-slot modes have been completed.

3.3.5 Deviation from Test Standard

No deviation.



3.3.6 Test Results

GFSK

Mode	Number of Hopping Channel	Number of transmission in a period (channel number*0.4 sec)				Length of transmission time (msec)	Result (msec)	Limit (msec)	Verdict
		Period (sec)	Sweep time (sec)	times in a sweep	times in a period				
1Mbps	34	13.6	13.6	25	25	7.934	198.35	400	Pass

Note: Test plots of the transmitting time slot are shown as below.

GFSK

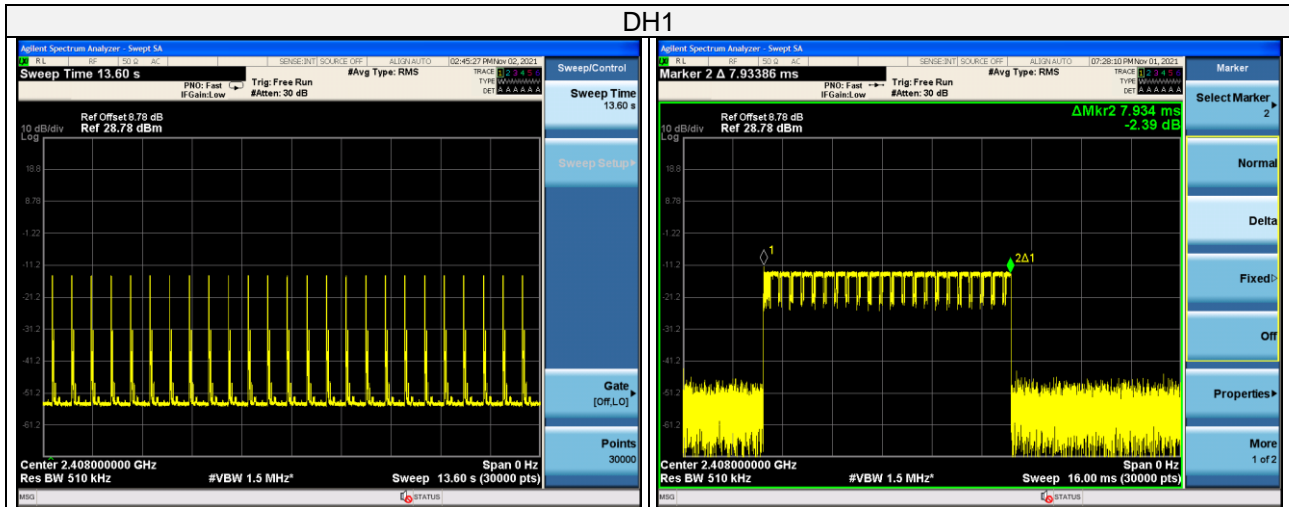



3.4 Channel Bandwidth

3.4.1 Limits of Channel Bandwidth Measurement

For frequency hopping system operating in the 2400-2483.5 MHz, if the 20 dB bandwidth of hopping channel is greater than 25 kHz, two-thirds 20 dB bandwidth of hopping channel shall be a minimum limit for the hopping channel separation.

3.4.2 Test Setup

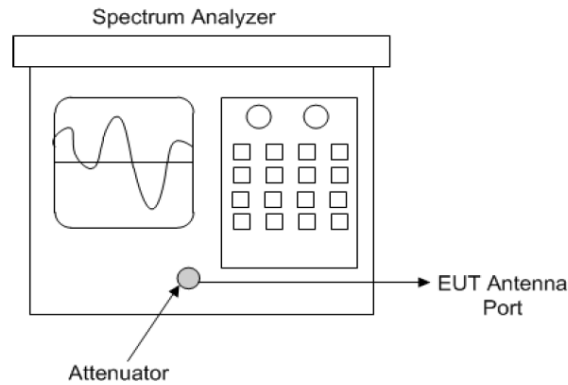

Spectrum analyzer test configuration

3.4.3 Test Instruments

Refer to section 5 to get information of above instrument.

3.4.4 Test Procedure

- Check the calibration of the measuring instrument using either an internal calibrator or a known signal from an external generator.
- Turn on the EUT and connect it to measurement instrument. Then set it to any one convenient frequency within its operating range. Set a reference level on the instrument equal to the highest peak value.
- Measure the frequency difference of two frequencies that were attenuated 20 dB from the reference level. Record the frequency difference as the emission bandwidth.
- Repeat above procedures until all frequencies measured were complete.

3.4.5 Deviation from Test Standard

No deviation.

3.4.6 EUT Operating Condition

The software provided by client enabled the EUT to transmit and receive data at lowest, middle and highest channel frequencies individually.



3.4.7 Test Results

Channel	Frequency (MHz)	20dB Bandwidth (MHz)
		GFSK
0	2408	2.075
16	2440	2.080
33	2474	2.080

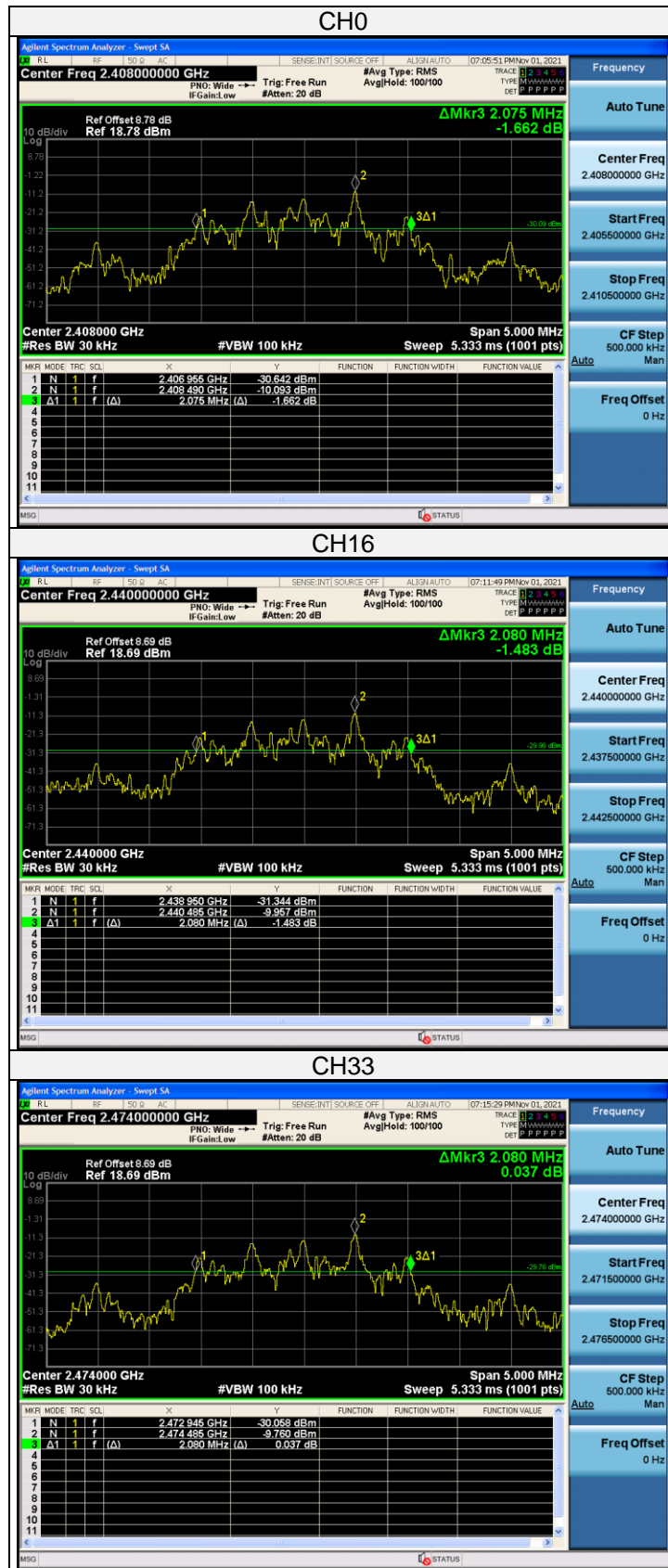

Lab: [Hwa-Hsing \(Dongguan\) Testing Co., Ltd.](#)
Address: [No.101, Bld N1, Yuyuan 2Rd, Yuyuan Industrial Park, HuangJiang Town, Dongguan, China](#)

Tel: [0769-83078199](tel:0769-83078199)
Web.: www.hwa-hsing.com
E-Mail: customerservice.dg@hwa-hsing.com

Release
[Ver. 1.4](#)



3.5 Occupied Bandwidth Measurement

3.5.1 Test Setup

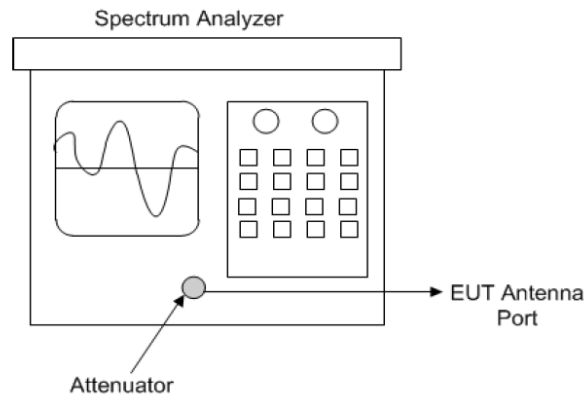

Spectrum analyzer test configuration

3.5.2 Test Instruments

Refer to section 5 to get information of above instrument

3.5.3 Test Procedure

The transmitter output was connected to the spectrum analyzer through an attenuator. The bandwidth of the fundamental frequency was measured by spectrum analyzer with resolution bandwidth in the range of 1% to 5% of the anticipated emission bandwidth, and a video bandwidth at least 3x the resolution bandwidth and set the detector to PEAK. The width of a frequency band such that, below the lower and above the upper frequency limits, the mean powers emitted are each equal to a specified percentage 0.5% of the total mean power of a given emission.

3.5.4 Deviation from Test Standard

No deviation.

3.5.5 EUT Operating Conditions

The software provided by client to enable the EUT under transmission condition continuously at lowest, middle and highest channel frequencies individually.



3.5.6 Test Results

Channel	Frequency (MHz)	OccupiedBandwidth (MHz)
		GFSK
0	2408	2.059
16	2440	2.082
33	2474	2.149

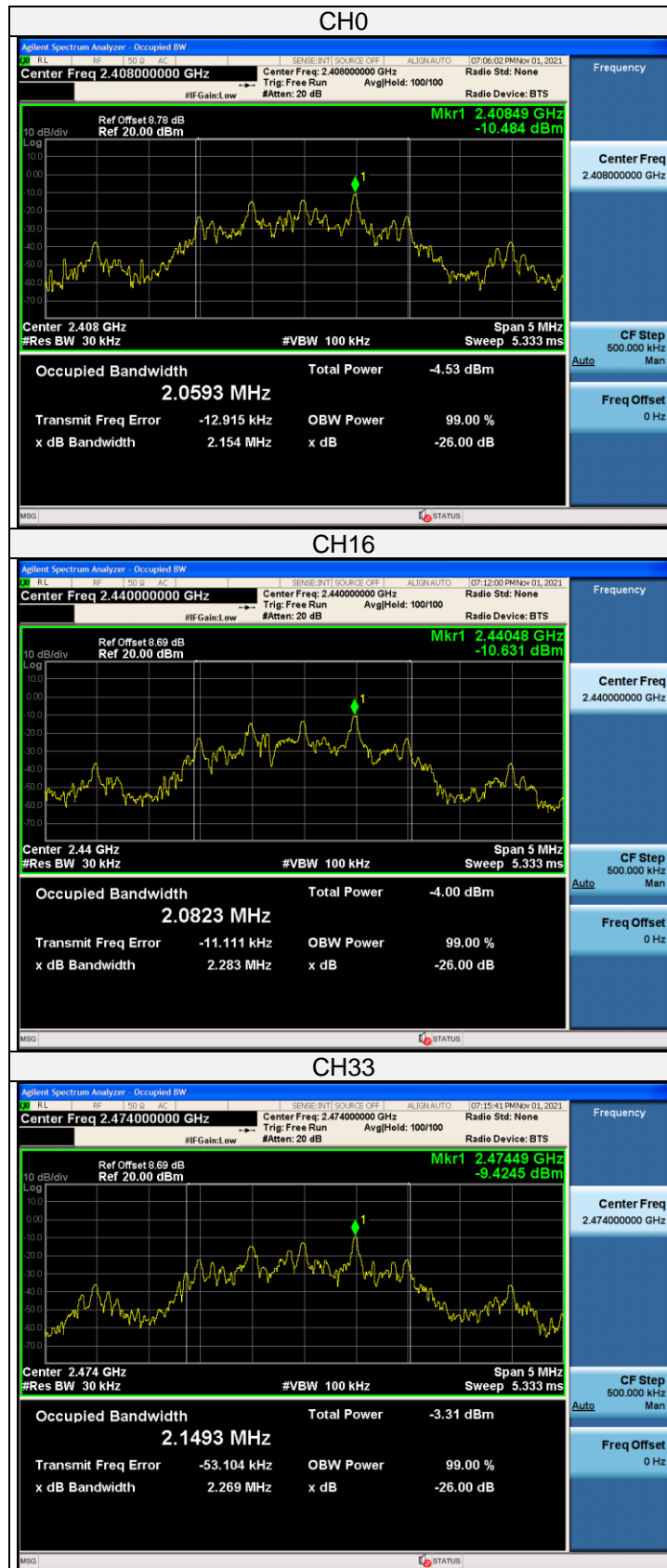



3.6 Hopping Channel Separation

3.6.1 Limits of Hopping Channel Separation Measurement

At least 25 kHz or two-third of 20 dB hopping channel bandwidth (whichever is greater).

3.6.2 Test Setup

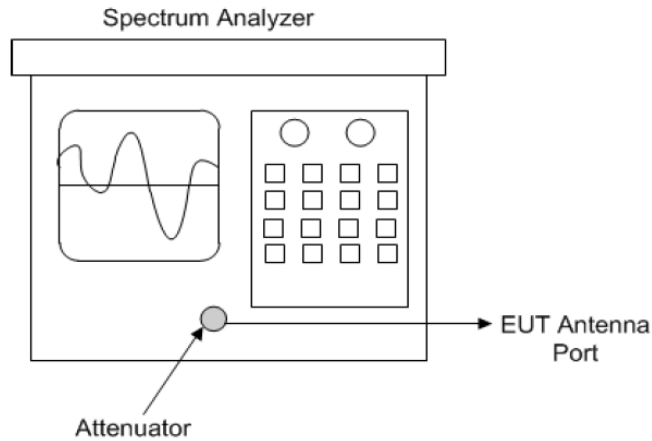

Spectrum analyzer test configuration

3.6.3 Test Instruments

Refer to section 5 to get information of above instrument.

3.6.4 Test Procedure

Measurement Procedure REF

- Check the calibration of the measuring instrument using either an internal calibrator or a known signal from an external generator.
- Turn on the EUT and connect it to measurement instrument. Then set it to any one convenient frequency within its operating range.
- By using the MaxHold function record the separation of two adjacent channels.
- Measure the frequency difference of these two adjacent channels by SA MARK function. And then plot the result on SA screen.
- Repeat above procedures until all frequencies measured were complete.

3.6.5 Deviation from Test Standard

No deviation.



3.6.6 Test Results

Channel No.	Frequency (MHz)	Adjacent Channel Separation (MHz)	Minimum Limit (MHz)	Pass / Fail
		GFSK	GFSK	
0	2408	1.999	1.383	Pass
16	2440	2.005	1.387	Pass
33	2474	2.005	1.387	Pass

Note:The minimum limit is two-third 20 dB bandwidth.

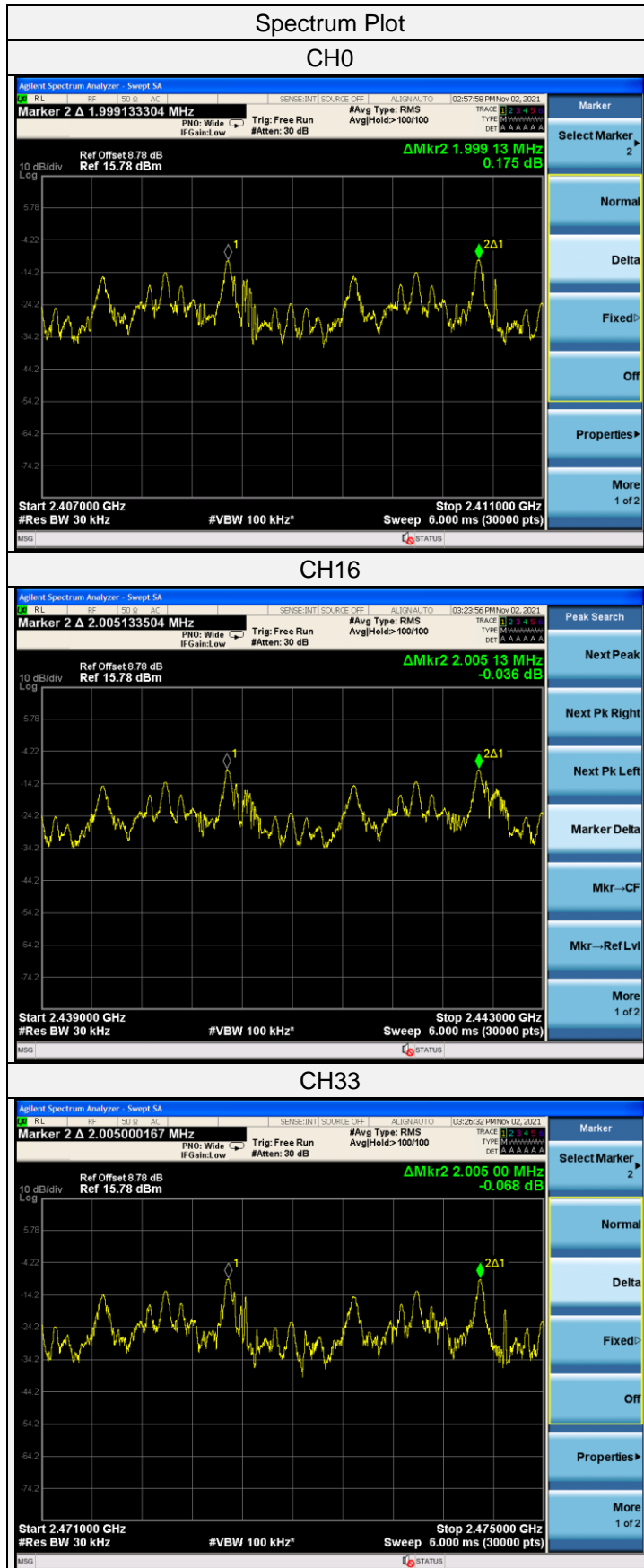

Lab: [Hwa-Hsing \(Dongguan\) Testing Co., Ltd.](#)
Address: [No.101, Bld N1, Yuyuan 2Rd, Yuyuan Industrial Park, HuangJiang Town, Dongguan, China](#)

Tel: [0769-83078199](tel:0769-83078199)
Web.: www.hwa-hsing.com
E-Mail: customerservice.dg@hwa-hsing.com

Release
[Ver. 1.4](#)



3.7 Maximum Output Power

3.7.1 Limits of Maximum Output Power Measurement

The Maximum Output Power Measurement is 125mW.

3.7.2 Test Setup

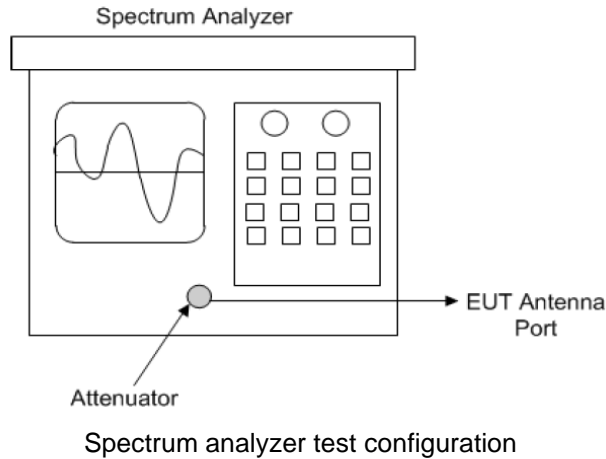

3.7.3 Test Instruments

Refer to section 5 to get information of above instrument.

3.7.4 Test Procedure

Measurement using a spectrum analyzer (SA), Selection of test method:

The proper test method is selected based on the following criteria:

- a) Use the following spectrum analyzer settings:
 - 1) Span: Approximately five times the 20 dB bandwidth, centered on a hopping channel.
 - 2) RBW > 20 dB bandwidth of the emission being measured.
 - 3) VBW \geq RBW.
 - 4) Sweep: Auto.
 - 5) Detector function: Peak.
 - 6) Trace: Max hold.
- b) Allow trace to stabilize.
- c) Use the marker-to-peak function to set the marker to the peak of the emission.



3.7.5 Deviation from Test Standard

No deviation.

3.7.6 EUT Operating Condition

The software provided by client enabled the EUT to transmit and receive data at lowest, middle and highest channel frequencies individually.

3.7.7 Test Results

Channel No.	Freq. (MHz)	Output Power (mW)	Output Power (dBm)	Power Limit (mW)	Pass / Fail
		GFSK	GFSK		
0	2408	0.124	-9.08	125	Pass
39	2440	0.116	-9.36	125	Pass
78	2474	0.138	-8.60	125	Pass



GFSK

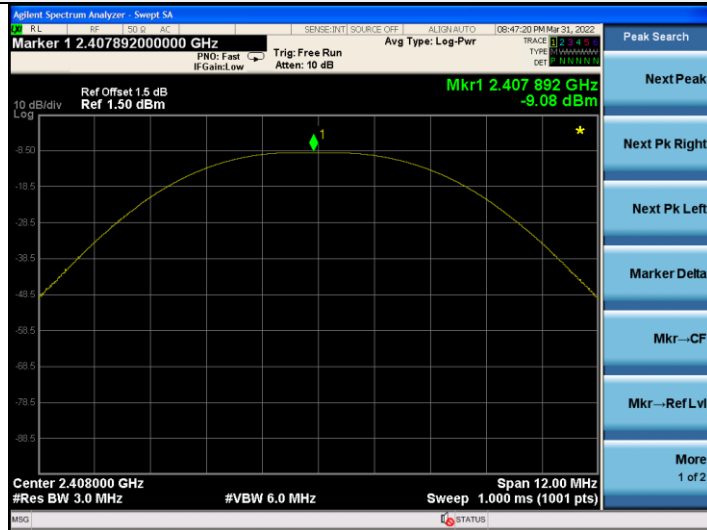

CH0

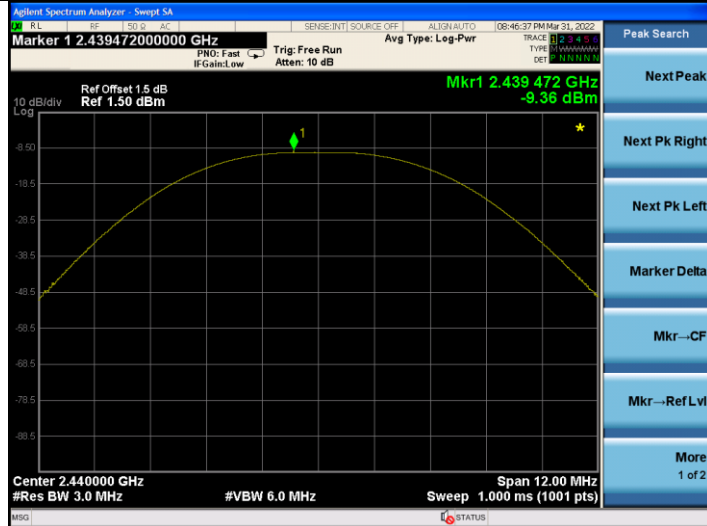

CH16

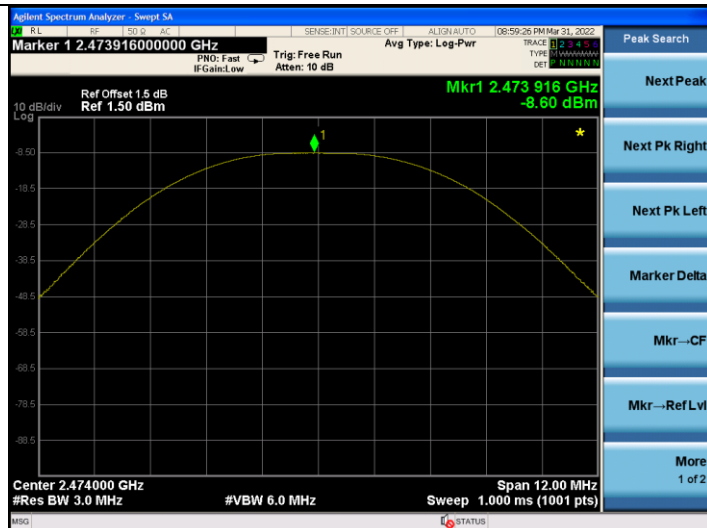

CH33



3.8 Conducted Out of Band Emission Measurement

3.8.1 Limits of Conducted Out of Band Emission Measurement

Below -20dB of the highest emission level of operating band (in 100KHz RBW).

3.8.2 Tets Setup

- FHSS emissions Subclause 7.8.8 of ANSI C63.10 is applicable.

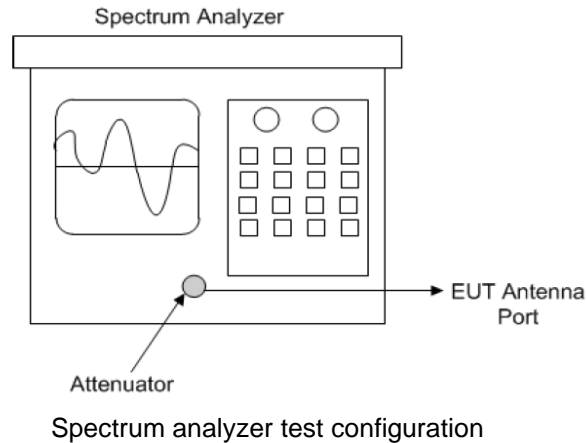

3.8.3 Test Instruments

Refer to section 5 to get information of above instrument.

3.8.4 Test Procedure

- 1) Set instrument center frequency to test channel center frequency.
- 2) Set the RBW= 100 kHz)
- 3) Set the VBW $\geq 3 \times$ RBW
- 4) Detector = peak
- 5) Sweep time = auto coupling
- 6) Trace mode =max hold
- 7) Allow trace to fully stabilize
- 8) Use the peak marker function to determine the maximum amplitude level.

3.8.5 Deviation from Test Standard

No deviation.

3.8.6 EUT Operating Condition

The software provided by client enabled the EUT to transmit and receive data at lowest, middle and highest channel frequencies individually.



3.8.7 Test Results

The spectrum plots are attached on the following images. D1 line indicates the highest level, D2 line indicates the 20dB offset below D1. It shows compliance with the requirement.

GFSK

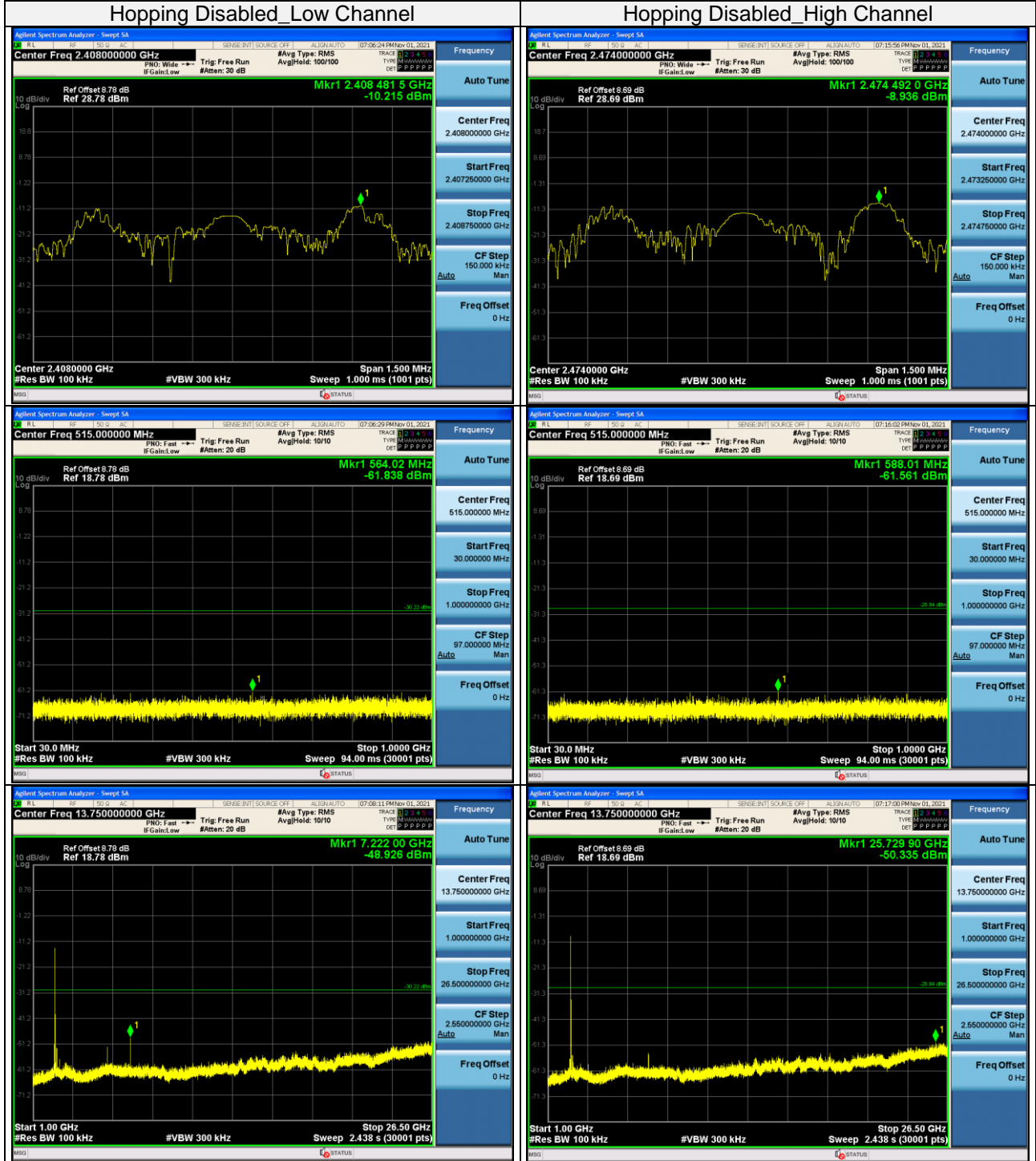



Hopping Disabled_Mid Channel

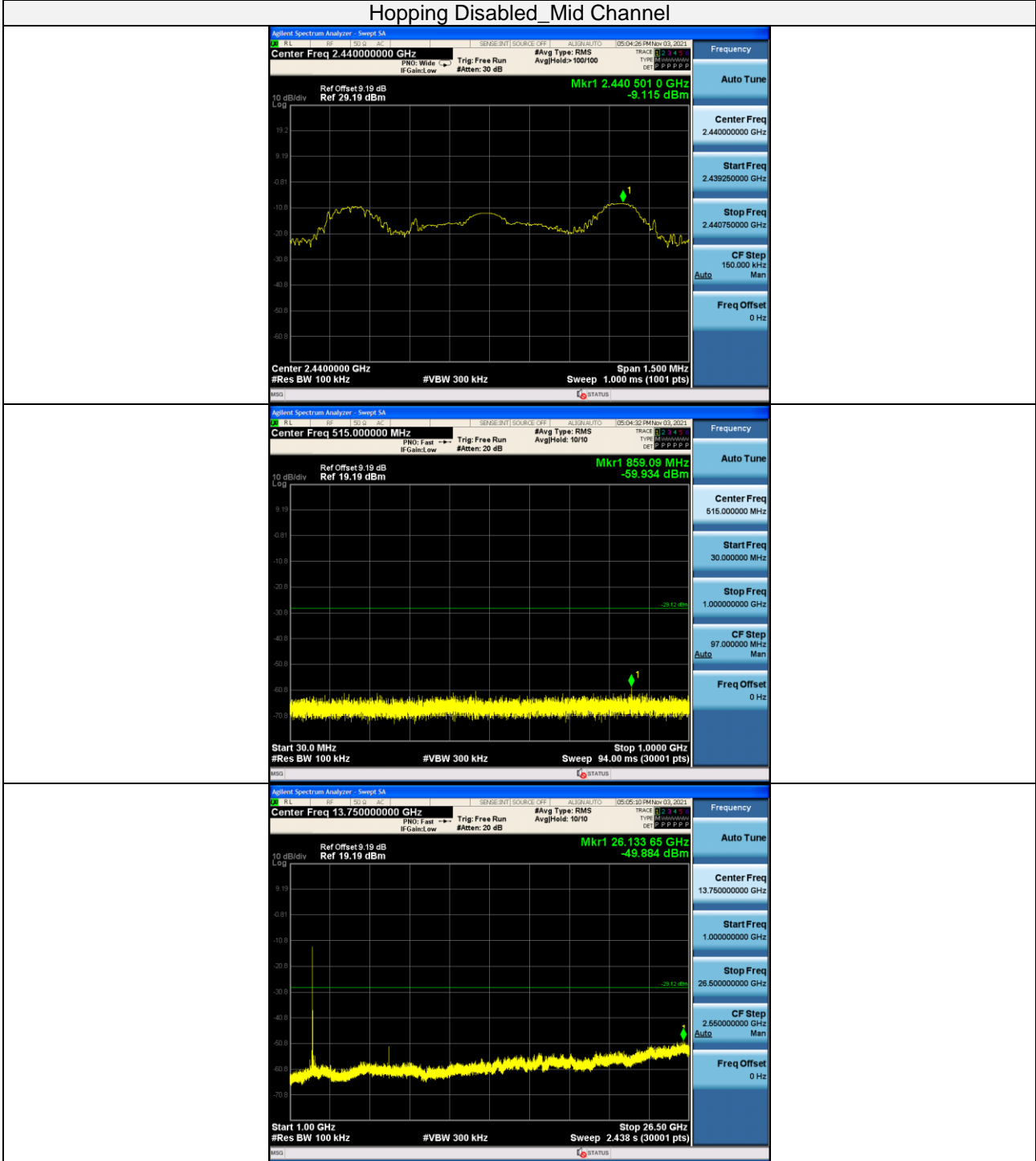



Bandedge: GFSK

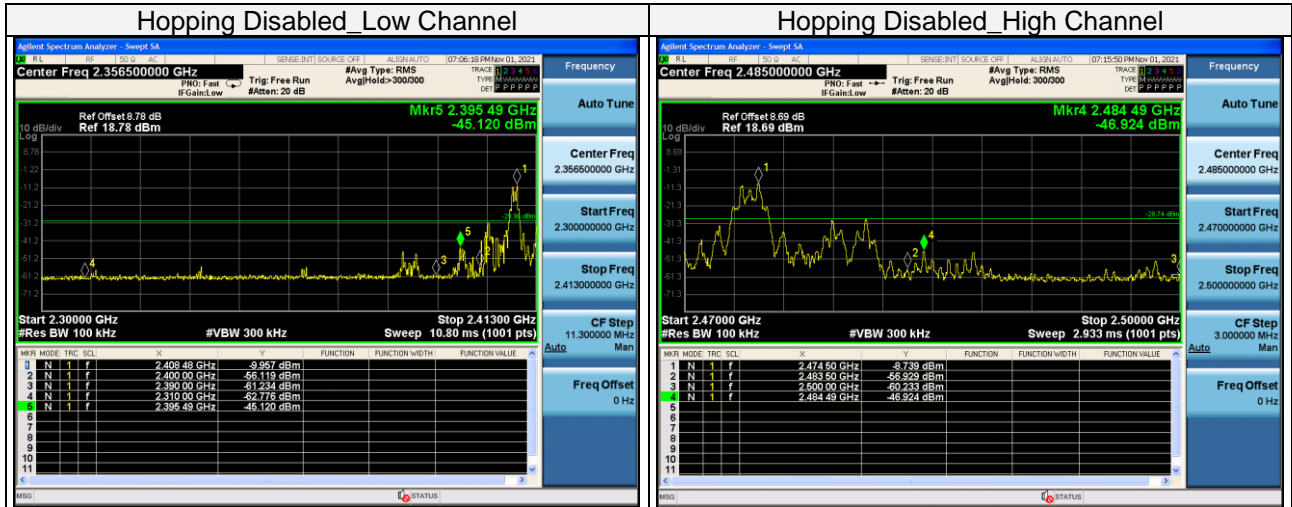

GFSK

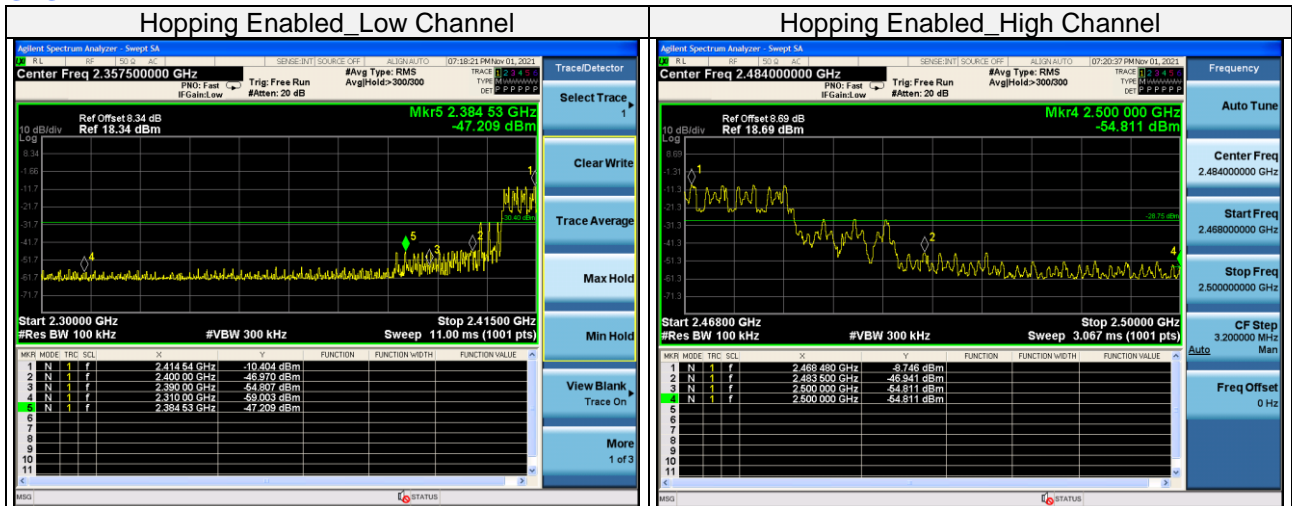



HWA-HSING Test Report No.: 210823KH02-RF-US-01

4 Pictures of Test Arrangements

Please refer to the attached file (Test Setup Photo).



5 Test Instruments

Description & Manufacturer	Model No.	Serial No.	Due Date of Calibration
Spectrum Keysight	N9020A	MY51240612	2022/09/12
Spectrum Analyzer Rohde&Schwarz	FSV-40N	101783	2022/09/12
Power Meter 10Hz~18GHz Tonscend	JS0806-2	188060126	2022/09/12
Signal generator Keysight	E4421B	GB40051020	2022/09/12
Signal generator Keysight	N5182A	MY47420944	2022/09/12
Test Software Tonscend	JS0806-2	NA	NA
Hygrothermograph Yuhuaze	HTC-1	NA	2022/09/12

Note:

1. The calibration interval of the above test instruments is 12 months and the calibrations are traceable to CEPREI/CHINA.
2. The test was performed in Chamber 1.



Appendix – Information on the Testing Laboratories

We, [Hwa-Hsing \(Dongguan\) Co., Ltd.](#), A global provider of TESTING and CERTIFICATION services for consumer products, electronic products and wireless information technology products. Adhering to the core values “HONEST and TRUSTWORTHY, OBJECTIVE and IMPARTIALITY, RIGOROUS and AFFICIENT”, commitment to provide professional, perfect and efficient comprehensive ONE-STOP solution of TESTING and CERTIFICATION services for Manufacturers, Buyers, Traders, Brands, Retailers. Assist client to better manage risk, protect their brands, reduce costs and cut time to over 150 markets in global. Our laboratories are FCC recognized accredited test firms and accredited and approved according to ISO/IEC 17025.

If you have any comments, please feel free to contact us at the following:

Lab Address: [No.101, Bld N1, Yuyuan 2Rd, Yuyuan Industrial Park, HuangJiang Town, Dongguan, China](#)

Contact Tel: [0769-83078199](tel:0769-83078199)

Email: Customerservice.dg@hwa-hsing.com

Web Site: www.hwa-hsing.com

The address and road map of all our labs can be found in our web site also.

--- END ---