



※ Please check this manual for instructions on how to use this manual prior to installing and operating this product.

USER'S MANUAL

Rear Sensor WRSS3200

Product Code 592846(2sensor)
Product Code 592848(4sensor)

- Speaks,Beepsound back to the situation of rear injury
- Display indicator on the display
- Distinguish LEDs by separating obstacles from both sides



■ Component

• Display 1psc



•Main Unit..... 1psc



• Sensor (Attachment type).....2psc or 4psc
Available to 4psc



•For sensor 2, code 4,5m
•For sensor 4, code differ in length
from 4.5m/2psc to 7M/2psc

•Waterproof case(option)



•Power cable(3m)..... 1psc



•Extension cable10m ... 1psc / 15m ... 17H



• Display anchorage
bracket



• Main Unit
double-sided
tape



• Sensor
double-sided
extra tape



• Power cable
one-touch coupler



※0,3~0,85 thickness
Wiring code used

• Bracket
double-sided



• Manuel



■ Main Unit connector



① Power cable

② Display

③ Sensor1 (Left-7m)

④ Sensor2 (left-4.5m)

⑤ Sensor1 (right-4.5m)

⑥ Sensor2 (left-7m)

■ Display



①

②

③



④

⑤

- ① Blinking when the left side of the injury is near Obstacle
- ② Mark the distance between the sensor and the obstacle from 2m
- ③ Blinking when the right side of the injury is near Obstacle
- ④ volume control
- ⑤ RUSS2000E is unavailable.

■ How to use

distance	Guide voice	Display
2m over	none	none
150cm~200cm	slow BEEP sound	·Display distance of obstruction in 10 cm
100cm~150cm	a little fast BEEP sound	·Sensor LED flashing to determine location of obstruction
50cm~100cm	Stop please (voice)	·Sensor LED flashing to determine location of obstruction
40cm	Fast tempo BEEP sound	·0.0 display
30cm under	Fast BEEP sound	·Sensor LED flashing to determine location of obstruction

※The left and right side LEDs show the position of the left and right hand side of the object when the obstacle is detected.
If both left and right sides have obstacles, the near side should be placed first display

■ Sensor installation

- For sensor 2, refer to drawing 1 to locate the position of the upper or lower back.
- The sensor is held parallel.
 - ※ If the sensor leans or tilts downwards, malfunction may occur.
- If fitted, place it at a height of not less than 60 cm above the ground.
- Leave the sensor at least 70 cm apart.
- Leave the sensor at least 20 cm apart from the zero side .
- Between the sensors, 100 cm to 120 cm is the minimum width of the rectangle.

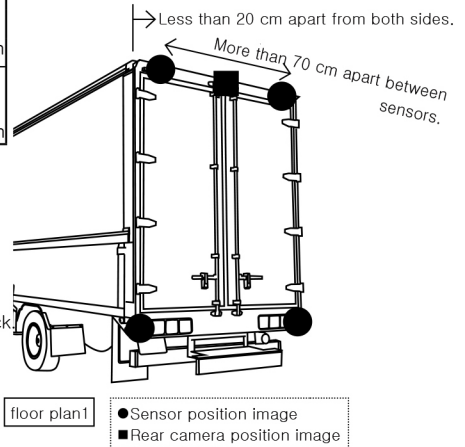

- ※Doing so may cause distortion of the sensor's wiring, machiningmorting it, and initiating a malfunction.(Cut-off prohibited)
- ※Processing or modification shall be excluded from warranty for warranty service, such as repair or replacement.

■ Sensor sensing range

Top view

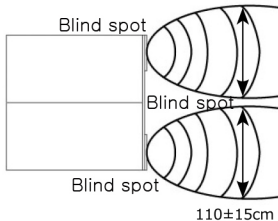

- The output signal from the sensor is radiated in a factory-shaped shape.

Side view

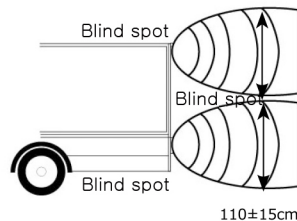

•Upper mounting point(The principal points in the case of a shade)

⇒ A vehicle with a shade or protruding edge on the upper part of the head is marked with an awning or projection
Check and fix the operation if it does not interfere with the operation.

•Under mounting point(The principal points due to Footstep Effect)

⇒ Ensure that no obstructions or projections are found in the upper and lower sides of the sensor face (within 30 to 40 cm).

It is recommended to check the random operation before fastening the sensor. Depending on the height of the protrusion and the width of the folds, the signal may affect the signal. You may need to adjust the distance adjustment or adjust the angle of the sensor.

(Angle control refers to adding additional double-sided tape between the sensor and the double-sided tape. Please use it.)

floor plan2

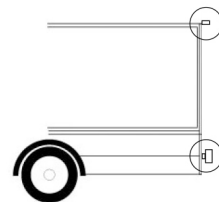

■ Installation of Display

- It is possible to mount the monitor to the monitor stand using a dedicated bracket as shown in Photo 2.
- Remove a fixed bolt from the monitor and monitor stand by inserting a dedicated bracket between the fixing bolts of the monitor stand on the monitor stand. Hold together.
- Prepare the double-sided tape to secure the display.

If you do not secure firmly, make sure you hold it securely, so you can fix it firmly.



Picture1



Picture2

Image (frontal) of bracket installation

■ Installation of Main Unit

1. Electrical wiring

- (1) Check the positive (positive) cable and negative cable of the reverse signal around the tail lamp.
 - (2) The + power cable (Red) of this unit is a + line of the reverse signal ; - Power cables (Black) or Connect to the body wire (GND).
 - (3) Cable cables with cable ties.
- ※ Be sure to remove the power from the reverse signal.
- ※ One-touch coupler (Red) is also available from 0.3 to 0.85 sp. Do not use thinner wiring.

2. Installation of Main Unit

- (1) The main body attaches to the inside of the casing (optional) or inside the inner passenger compartment of the passenger compartment. ※ Avoid areas where humidity is high.
- (2) Connect the power cable and the sensor cable to the sequence shown in the indicated color (blackback).

3. Connecting the connector on the main unit

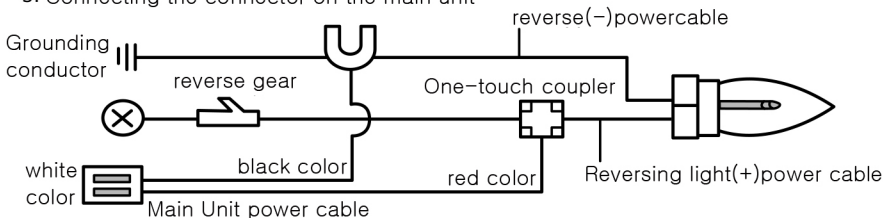

■ Cautions for installation or use

1. Be careful not to operate or malfunction in the following situations :

- (1) If non detectable items are rearward.
 - Thin objects such as needles, rope, wire, barbed wire, etc.
 - Objects that absorb ultrasonic waves, such as cotton, sponge, and snow.
- (2) Cause of malfunction
 - In case of a power source other than the reverse signal
 - Revealing gravel, grass, mounds of sand, hilly roads, and hilly areas.
 - The sensor faces foreign substances such as snow or sand.
 - In case the sensor froze in the winter
 - A communication or electronic device with a large output (noise) is inside the vehicle.

2. This product performs a stable operation when driving at less than 5 km/h.

3. This product is an ultrasound device. Depending on the ambient environment, there may be a difference in voice guidance or distance.



Warning

※ This product is a device that supports safety during reversing or parking manoeuvres. Regardless of whether this product is fitted or not. Make sure to check with your eyes and move safely. The amount of such errors or losses occurring in reverse order, such as when reversing : Concerning personnel incidents and damage, we shall not be held liable for the damage.

■ Specification

category	Specification
Sensing distance	2m distance indicator, voice or BEEP sound guide (10 cm in distance)
Sensing pattern	Fan type radiation curve
Sensing angle	Upper, left, and right each $75 \pm 15^\circ$ (110±15cm)(-6dB Directivity)
Warning sound	Step 4 Negative or BEEP sound : 0.0-0.5/0.6-1.0/1.1-1.5/1.6-2.0m
Warning Indicator	7-Segment Show LED distance indicator or sensor position(2pcs)LED
Sensor	2pcs(sensor cable 4.5m, 2pcs Additional Available : Separate sale) 4pcs(sensor cable 4.5m x 2pcs/7m x 2pcs)
Operating voltage	12 / 24V Free (+10V ~ +30V)
Sensor type	Attachment type(Double-sided tape and waterproof)
Communication type	Wired (display extension wiring : 25 m)
Power consumption	Display : ~ 250 mA under, Main Unit : ~ 600mA under (12 Volt / 24 V)
Operating temperature	-25° ~ +60°
Size	Display : 97 x 71 x 25mm Main Unit : 88 x 60 x 23mm

■ If you think it's a fault,

Even if reverse gear is inserted, On display Voice guide	➔	<ul style="list-style-type: none"> • Please check the power supply. • Make sure that the power wires are plugged into the main unit and display. • Check the wiring of the wiring and the wiring loom. • Please check the reverse lights of the vehicle.
Behind the scenes Incomprehensibility	➔	<ul style="list-style-type: none"> • Check the sensor wiring.(Check the operation of each sensor during initial operation) • Check the rear angle of the sensor. • Make sure that there is no foreign matter in the sensor. • Make sure that the reverse light is not low. (The operating voltage is at least 10 V or higher.)
There's no obstacle. Voice guidance Market price quotation	➔	<ul style="list-style-type: none"> • Check the orientation or angle of the sensor. • Make sure the sensor is free from debris. • Ensure strong electromagnetic radiation occurs around peripheral devices and confirm the progress of the unit.

FCC STATEMENT :

This device complies with Part 15 of the FCC Rules. Operation is subject to the following two conditions:

- (1) This device may not cause harmful interference, and
- (2) This device must accept any interference received, including interference that may cause undesired operation.

Warning: Changes or modifications not expressly approved by the party responsible for compliance could void the user's authority to operate the equipment.

NOTE: This equipment has been tested and found to comply with the limits for a Class B digital device, pursuant to Part 15 of the FCC Rules. These limits are designed to provide reasonable protection against harmful interference in a residential installation. This equipment generates uses and can radiate radio frequency energy and, if not installed and used in accordance with the instructions, may cause harmful interference to radio communications. However, there is no guarantee that interference will not occur in a particular installation. If this equipment does cause harmful interference to radio or television reception, which can be determined by turning the equipment off and on, the user is encouraged to try to correct the interference by one or more of the following measures:

- Reorient or relocate the receiving antenna.

- Increase the separation between the equipment and receiver.

- Connect the equipment into an outlet on a circuit different from that to which the receiver is connected.

- Consult the dealer or an experienced radio/TV technician for help.