



RF TEST REPORT

Applicant UAB TELTONIKA TELEMATICS
FCC ID 2A3HUFMM920
Product Fleet Management System
Brand TELTONIKA TELEMATICS
Model FMM920-Q3IB0
Report No. R2208A0723-R1
Issue Date September 16, 2022

TA Technology (Shanghai) Co., Ltd. tested the above equipment in accordance with the requirements in **FCC CFR47 Part 2 (2021)/ FCC CFR 47 Part 22H (2021)**. The test results show that the equipment tested is capable of demonstrating compliance with the requirements as documented in this report.

Prepared by: Xu Ying

Approved by: Xu Kai

TA Technology (Shanghai) Co., Ltd.

Building 3, No.145, Jintang Rd, Tangzhen Industry Park, Pudong Shanghai, China

TEL: +86-021-50791141/2/3

FAX: +86-021-50791141/2/3-8000



TABLE OF CONTENT

- 1. Test Laboratory4
 - 1.1. Notes of the Test Report 4
 - 1.2. Test facility.....4
 - 1.3. Testing Location 4
- 2. General Description of Equipment under Test.....5
 - 2.1. Applicant and Manufacturer Information5
 - 2.2. General Information..... 5
- 3. Applied Standards6
- 4. Test Configuration.....7
- 5. Test Case8
 - 5.1. RF Power Output and Effective Radiated Power8
 - 5.2. Radiated Spurious Emission 9
- 6. Test Result12
 - 6.1. RF Power Output and Effective Radiated Power 12
 - 6.2. Radiated Spurious Emission 14
- 7. Main Test Instruments16
- ANNEX A: The EUT Appearance17
- ANNEX B: Test Setup Photos18



Summary of measurement results

No.	Test Case	Clause in FCC rules	Verdict
1	RF Power Output and Effective Radiated Power	2.1046 22.913(a)(5)	PASS
2	Radiated Spurious Emission	2.1053 / 22.917 (a)	PASS
Date of Testing: August 5, 2022 ~ August 17, 2022 Date of Sample Received: August 5, 2022			
Note: PASS: The EUT complies with the essential requirements in the standard. FAIL: The EUT does not comply with the essential requirements in the standard. All indications of Pass/Fail in this report are opinions expressed by TA Technology (Shanghai) Co., Ltd. based on interpretations and/or observations of test results. Measurement Uncertainties were not taken into account and are published for informational purposes only.			

This report only tests Effective Radiated Power and Radiated Spurious Emission. For other test items, please refer to Module Report (Report No: R2003A0152-R1, FCC ID: XMR201910BG95M3).



1. Test Laboratory

1.1. Notes of the Test Report

This report shall not be reproduced in full or partial, without the written approval of **TA technology (shanghai) co., Ltd.** The results documented in this report apply only to the tested sample, under the conditions and modes of operation as described herein. Measurement Uncertainties were not taken into account and are published for informational purposes only. This report is written to support regulatory compliance of the applicable standards stated above.

1.2. Test facility

FCC (Designation number: CN1179, Test Firm Registration Number: 446626)

TA Technology (Shanghai) Co., Ltd. has been listed on the US Federal Communications Commission list of test facilities recognized to perform measurements.

A2LA (Certificate Number: 3857.01)

TA Technology (Shanghai) Co., Ltd. has been listed by American Association for Laboratory Accreditation to perform measurement.

1.3. Testing Location

Company: TA Technology (Shanghai) Co., Ltd.
Address: Building 3, No.145, Jintang Rd, Tangzhen Industry Park, Pudong Shanghai, China
City: Shanghai
Post code: 201201
Country: P. R. China
Contact: Xu Kai
Telephone: +86-021-50791141/2/3
Fax: +86-021-50791141/2/3-8000
Website: <http://www.ta-shanghai.com>
E-mail: xukai@ta-shanghai.com

2. General Description of Equipment under Test

2.1. Applicant and Manufacturer Information

Applicant	UAB TELTONIKA TELEMATICS
Applicant address	Saltoniskiu st. 9B-1, Vilnius, Lithuania
Manufacturer	UAB TELTONIKA TELEMATICS
Manufacturer address	Saltoniskiu st. 9B-1, Vilnius, Lithuania
Factory	UAB TELTONIKA EMS
Factory address	Ditvos st.6, Vilnius, Lithuania

2.2. General Information

EUT Description			
Model	FMM920-Q3IB0		
IMEI	863257068183666		
Hardware Version	FMM920-03		
Software Version	FMB.Ver.03.28.02		
Power Supply	External power supply		
Antenna Type	Internal Antenna		
Antenna Gain	- 2.07 dBi		
Test Mode(s)	GSM 850; LTE Band 5;		
Test Modulation	(GSM/GPRS)GMSK, (EGPRS) GMSK/ 8PSK; (LTE) QPSK, 16QAM;		
GPRS Multislot Class	33		
EGPRS Multislot Class	33		
LTE Category	M1		
Maximum E.R.P.	GSM 850:	32.16 dBm	
	LTE Band 5:	18.64 dBm	
Rated Power Supply Voltage	12V		
Operating Voltage	Minimum: 10V Maximum: 30V		
Operating Temperature	Lowest: -20°C Highest: +85°C		
Operating Frequency Range(s)	Band	Tx (MHz)	Rx (MHz)
	GSM850	824 ~ 849	869 ~ 894
	LTE Band 5	824 ~ 849	869 ~ 894
Note: 1. The EUT is sent from the applicant to TA and the information of the EUT is declared by the applicant.			



3. Applied Standards

According to the specifications of the manufacturer, it must comply with the requirements of the following standards:

Test standards:

FCC CFR 47 Part 22H (2021)

FCC CFR47 Part 2 (2021)

Reference standard:

ANSI C63.26-2015

KDB 971168 D01 Power Meas License Digital Systems v03r01

4. Test Configuration

Radiated measurements are performed by rotating the EUT in three different orthogonal test planes. EUT stand-up position (Z axis), lie-down position (X, Y axis). Receiver antenna polarization (horizontal and vertical), the worst emission was found in position (Z axis, vertical polarization for GSM Band; X axis, horizontal polarization for LTE Band) and the worst case was recorded.

All mode and data rates and positions and RB size and modulations were investigated.

Subsequently, only the worst case emissions are reported.

The following testing in GSM/ LTE is set based on the maximum RF Output Power.

Test modes are chosen to be reported as the worst case configuration below:

Test items	Modes/Modulation
	GSM 850
RF Power Output and Effective Radiated power	GSM GPRS EGPRS
Radiated Spurious Emission	GSM

Test modes are chosen as the worst case configuration below for LTE Band 5:

Test items	Bandwidth (MHz)				Modulation		RB			Test Channel		
	1.4	3	5	10	QPSK	16QAM	1	50%	100%	L	M	H
RF power output and Effective Radiated power	O	O	O	O	O	O	O	O	O	O	O	O
Radiated Spurious Emission	O	-	O	O	O	-	O	-	-	-	O	-
Note	1. The mark "O" means that this configuration is chosen for testing. 2. The mark "-" means that this configuration is not testing.											

5. Test Case

5.1. RF Power Output and Effective Radiated Power

Ambient condition

Temperature	Relative humidity	Pressure
23°C ~25°C	45%~50%	101.5kPa

Methods of Measurement

During the process of the testing, The EUT was connected to the Base Station Simulator with a known loss. The EUT is controlled by the Base Station Simulator test set to ensure max power transmission with proper modulation.

ERP can then be calculated as follows:

$$\text{EIRP (dBm)} = \text{Output Power (dBm)} - \text{Losses (dB)} + \text{Antenna Gain (dBi)}$$

where:dBd refers to gain relative to an ideal dipole.

$$\text{EIRP (dBm)} = \text{ERP (dBm)} + 2.15 \text{ (dB)}.$$

Test Setup

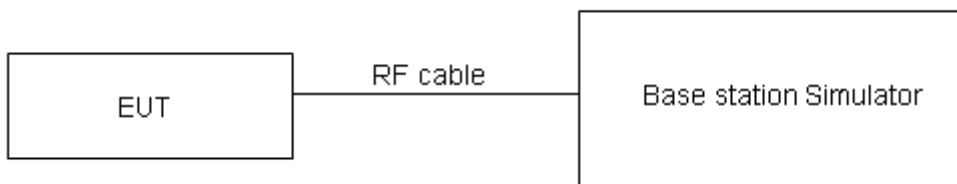

Limits

No specific RF power output requirements in part 2.1046.

Rule Part 22.913(a)(5) specifies that "Mobile/portable stations are limited to 7 watts ERP".

Limit	≤ 7 W (38.45 dBm)
-------	-------------------

Measurement Uncertainty

The assessed measurement uncertainty to ensure 95% confidence level for the normal distribution is with the coverage factor $k = 2$, $U = 0.4 \text{ dB}$ for RF power output, $k = 2$, $U = 1.19 \text{ dB}$ for ERP.

Test Results

Refer to the section 6.1 of this report for test data.

5.2. Radiated Spurious Emission

Ambient condition

Temperature	Relative humidity	Pressure
23°C ~25°C	45%~50%	101.5kPa

Method of Measurement

1. The testing follows FCC KDB 971168 v03r01 Section 5.8 and ANSI C63.26-2015.
2. Below 1GHz: The EUT is placed on a turntable 0.8 meters above the ground in the chamber, 3 meter away from the antenna. The maximal emission value is acquired by adjusting the antenna height, polarisation and turntable azimuth. Normally, the height range of antenna is 1 m to 4 m, the azimuth range of turntable is 0° to 360°, and the receive antenna has two polarizations Vertical (V) and Horizontal (H). Above 1GHz: (Note: the FCC's permission to use 1.5m as an alternative per TCBC Conf call of Dec. 2, 2014.) The EUT is placed on a turntable 1.5 meters above the ground in the chamber, 3 meter away from the antenna. The maximal emission value is acquired by adjusting the antenna height, polarisation and turntable azimuth. Normally, the height range of antenna is 1 m to 4 m, the azimuth range of turntable is 0° to 360°, and the receive antenna has two polarizations Vertical (V) and Horizontal (H).
3. A loop antenna, A log-periodic antenna or horn antenna shall be substituted in place of the EUT. The log-periodic antenna will be driven by a signal generator and the level will be adjusted till the same power value on the spectrum analyzer or receiver. The level of the spurious emissions can be calculated through the level of the signal generator, cable loss, the gain of the substitution antenna and the reading of the spectrum analyzer or receiver.
4. The EUT is then put into continuously transmitting mode at its maximum power level during the test. Set Test Receiver or Spectrum RBW=100kHz,VBW=300kHz, and the maximum value of the receiver should be recorded as (Pr).
5. The EUT shall be replaced by a substitution antenna. In the chamber, an substitution antenna for the frequency band of interest is placed at the reference point of the chamber. An RF Signal source for the frequency band of interest is connected to the substitution antenna with a cable that has been constructed to not interfere with the radiation pattern of the antenna. A power (PMea) is applied to the input of the substitution antenna, and adjust the level of the signal generator output until the value of the receiver reach the previously recorded (Pr). The power of signal source (PMea) is recorded. The test should be performed by rotating the test item and adjusting the receiving antenna polarization.
6. A amplifier should be connected to the Signal Source output port. And the cable should be connect between the Amplifier and the Substitution Antenna. The cable loss (Pcl), the Substitution Antenna Gain (Ga) and the Amplifier Gain (PAg) should be recorded after test.
7. The measurement results are obtained as described below:
Power(EIRP)=PMea- PAg - Pcl + Ga
The measurement results are amend as described below:
Power(EIRP)=PMea- Pcl + Ga
8. This value is EIRP since the measurement is calibrated using an antenna of known gain (2.15 dB) and known input power. ERP can be calculated from EIRP by subtracting the gain of the dipole, ERP

= EIRP-2.15dB.

The modulation mode and RB allocation refer to section 5.1, using the maximum output power configuration.

Test setup

9KHz~ 30MHz

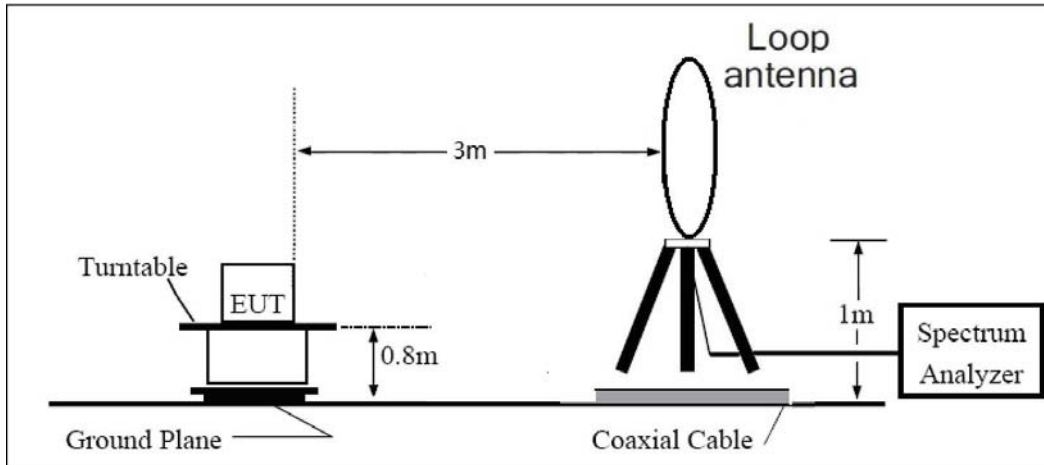

30MHz~ 1GHz

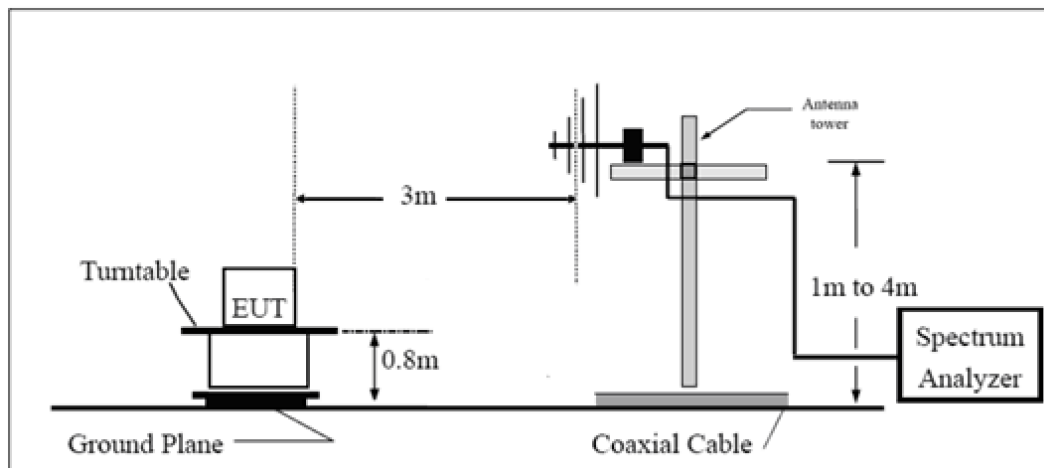

Above 1GHz

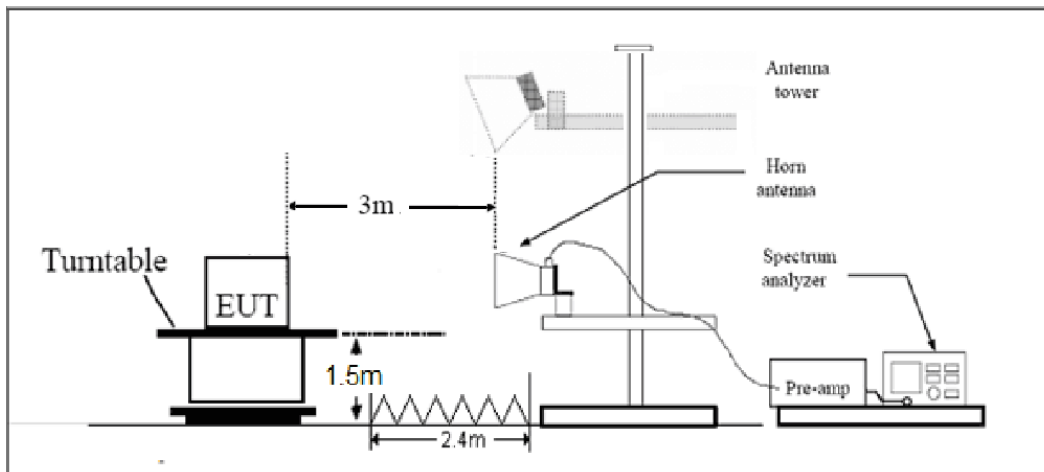

Note: Area side:2.4mX3.6m



Limits

Rule Part 22.917(a) specifies that “The power of any emission outside of the authorized operating frequency ranges must be attenuated below the transmitting power (P) by a factor of at least $43 + 10 \log (P)$ dB.”

Limit	-13 dBm
-------	---------

Measurement Uncertainty

The assessed measurement uncertainty to ensure 95% confidence level for the normal distribution is with the coverage factor $k = 1.96$, $U = 3.55$ dB.

Test Results

Refer to the section 6.2 of this report for test data.



6. Test Result

6.1. RF Power Output and Effective Radiated Power

RF Power Output refer to Module Report

GSM 850		Maximum Output Power (dBm)			ERP (dBm)		
		Channel 128	Channel 190	Channel 251	Channel 128	Channel 190	Channel 251
		824.2 (MHz)	836.6 (MHz)	848.8 (MHz)	824.2 (MHz)	836.6 (MHz)	848.8 (MHz)
GSM(GMSK)	Results	32.13	32.20	32.24	32.05	32.12	32.16
GPRS (GMSK)	1TXslot	32.20	32.05	32.07	32.12	31.97	31.99
	2TXslots	31.05	31.10	31.12	30.97	31.02	31.04
	3TXslots	29.51	29.10	29.14	29.43	29.02	29.06
	4TXslots	27.97	28.10	28.13	27.89	28.02	28.05
EGPRS (8PSK)	1TXslot	25.07	25.01	25.00	24.99	24.93	24.92
	2TXslots	24.32	24.12	24.20	24.24	24.04	24.12
	3TXslots	22.16	22.07	22.42	22.08	21.99	22.34
	4TXslots	20.87	21.02	21.03	20.79	20.94	20.95

LTE Band 5	Channel/ Frequency(MHz)	Index	RB#	RB#	Conducted Power (dBm)		ERP	
			RBstart	RBstart	QPSK	16QAM	QPSK	16QAM
			QPSK	16QAM	QPSK	16QAM	QPSK	16QAM
1.4MHz	20407/824.7	0	1#0	1#0	20.87	19.51	18.64	17.28
		0	6#0	5#0	18.82	19.48	16.59	17.25
	20525/836.5	0	1#0	1#0	20.24	20.45	18.01	18.22
		0	6#0	5#0	18.83	18.39	16.60	16.16
	20643/848.3	0	1#5	1#5	20.44	19.36	18.21	17.13
		0	6#0	5#0	18.61	19.31	16.38	17.08
3MHz	20415/825.5	0	1#0	1#0	20.50	20.38	18.27	18.15
		0	6#0	5#0	18.79	19.02	16.56	16.79
	20525/836.5	0	1#0	1#0	20.53	20.07	18.30	17.84
		0	6#0	5#0	18.91	18.99	16.68	16.76
	20635/847.5	1	1#5	1#5	20.44	19.42	18.21	17.19
		1	6#0	5#0	18.67	19.09	16.44	16.86
5MHz	20425/826.5	0	1#0	1#0	20.37	20.68	18.14	18.45
		0	6#0	5#0	19.94	19.73	17.71	17.50
	20525/836.5	0	1#0	1#0	20.41	20.58	18.18	18.35



	20625/846.5	0	6#0	5#0	19.97	19.89	17.74	17.66
		3	1#5	1#5	20.03	20.41	17.80	18.18
		3	6#0	5#0	19.86	19.91	17.63	17.68
10MHz	20450/829	0	1#0	1#0	20.37	20.78	18.14	18.55
		0	4#0	4#0	20.56	20.28	18.33	18.05
	20525/836.5	0	1#0	1#0	20.41	20.74	18.18	18.51
		0	4#0	4#0	20.53	20.32	18.30	18.09
	20600/844	7	1#5	1#5	20.02	20.34	17.79	18.11
		7	4#2	4#2	20.30	20.08	18.07	17.85

6.2. Radiated Spurious Emission

Sweep the whole frequency band through the range from 9kHz to the 10th harmonic of the carrier, the emissions below the noise floor will not be recorded in the report.

GSM 850 CH-Middle

Harmonic	Frequency (MHz)	SG (dBm)	Cable Loss (dB)	Gain (dBi)	Antenna Polarization	ERP Level (dBm)	Limit (dBm)	Margin (dB)	Azimuth (deg)
2	1673.20	-53.98	1.70	8.70	Vertical	-49.13	-13.00	36.13	0
3	2509.80	-53.20	2.30	12.00	Vertical	-45.65	-13.00	32.65	45
4	3346.40	-59.15	2.70	12.70	Vertical	-51.30	-13.00	38.30	45
5	4183.00	-63.26	3.00	12.50	Vertical	-55.91	-13.00	42.91	0
6	5019.60	-60.23	3.40	12.50	Vertical	-53.28	-13.00	40.28	0
7	5856.20	-59.75	3.40	12.80	Vertical	-52.50	-13.00	39.50	225
8	6692.80	-59.61	4.10	11.50	Vertical	-54.36	-13.00	41.36	225
9	7529.40	-56.58	4.20	12.20	Vertical	-50.73	-13.00	37.73	0
10	8366.00	-57.53	4.30	12.50	Vertical	-51.48	-13.00	38.48	0

Note: 1. The other Spurious RF Radiated emissions level is no more than noise floor.
 2. The worst emission was found in the antenna is Vertical position.

LTE Band 5 1.4MHz CH-Middle

Harmonic	Frequency (MHz)	SG (dBm)	Cable Loss (dB)	Gain (dBi)	Antenna Polarization	ERP Level (dBm)	Limit (dBm)	Margin (dB)	Azimuth (deg)
2	1673.00	-55.28	1.70	8.70	Horizontal	-50.43	-13.00	37.43	180
3	2509.50	-35.06	2.30	12.00	Horizontal	-27.51	-13.00	14.51	135
4	3346.00	-63.79	2.70	12.70	Horizontal	-55.94	-13.00	42.94	180
5	4182.50	-64.18	3.00	12.50	Horizontal	-56.83	-13.00	43.83	225
6	5019.00	-60.19	3.40	12.50	Horizontal	-53.24	-13.00	40.24	0
7	5855.50	-59.41	3.40	12.80	Horizontal	-52.16	-13.00	39.16	135
8	6692.00	-58.29	4.10	11.50	Horizontal	-53.04	-13.00	40.04	315
9	7528.50	-56.64	4.20	12.20	Horizontal	-50.79	-13.00	37.79	45
10	8365.00	-56.08	4.30	12.50	Horizontal	-50.03	-13.00	37.03	0

Note: 1. The other Spurious RF Radiated emissions level is no more than noise floor.
 2. The worst emission was found in the antenna is Horizontal position.

LTE Band 5 5MHz CH-Middle

Harmonic	Frequency (MHz)	SG (dBm)	Cable Loss (dB)	Gain (dBi)	Antenna Polarization	ERP Level (dBm)	Limit (dBm)	Margin (dB)	Azimuth (deg)
2	1668.60	-55.79	1.70	8.70	Horizontal	-50.94	-13.00	37.94	135
3	2503.30	-64.23	2.30	12.00	Horizontal	-56.68	-13.00	43.68	180
4	3337.50	-65.39	2.70	12.70	Horizontal	-57.54	-13.00	44.54	135
5	4171.88	-63.69	3.00	12.50	Horizontal	-56.34	-13.00	43.34	225
6	5006.25	-59.73	3.40	12.50	Horizontal	-52.78	-13.00	39.78	45
7	5840.63	-59.15	3.40	12.80	Horizontal	-51.90	-13.00	38.90	180
8	6675.00	-57.98	4.10	11.50	Horizontal	-52.73	-13.00	39.73	315
9	7509.38	-57.44	4.20	12.20	Horizontal	-51.59	-13.00	38.59	45
10	8343.75	-55.87	4.30	12.50	Horizontal	-49.82	-13.00	36.82	90

Note: 1. The other Spurious RF Radiated emissions level is no more than noise floor.
 2. The worst emission was found in the antenna is Horizontal position.

LTE Band 5 10MHz CH-Middle

Harmonic	Frequency (MHz)	SG (dBm)	Cable Loss (dB)	Gain (dBi)	Antenna Polarization	ERP Level (dBm)	Limit (dBm)	Margin (dB)	Azimuth (deg)
2	1664.40	-56.51	1.70	8.70	Horizontal	-51.66	-13.00	38.66	135
3	2496.60	-62.78	2.30	12.00	Horizontal	-55.23	-13.00	42.23	180
4	3326.00	-65.02	2.70	12.70	Horizontal	-57.17	-13.00	44.17	0
5	4157.50	-63.99	3.00	12.50	Horizontal	-56.64	-13.00	43.64	180
6	4989.00	-59.50	3.40	12.50	Horizontal	-52.55	-13.00	39.55	45
7	5820.00	-60.75	3.40	12.80	Horizontal	-53.50	-13.00	40.50	90
8	6652.00	-57.94	4.10	11.50	Horizontal	-52.69	-13.00	39.69	135
9	7483.50	-57.74	4.20	12.20	Horizontal	-51.89	-13.00	38.89	315
10	8315.00	-55.84	4.30	12.50	Horizontal	-49.79	-13.00	36.79	45

Note: 1. The other Spurious RF Radiated emissions level is no more than noise floor.
 2. The worst emission was found in the antenna is Horizontal position.



7. Main Test Instruments

Name	Manufacturer	Type	Serial Number	Calibration Date	Expiration Date
Signal Analyzer	R&S	FSV40	101297	2021-12-12	2022-12-11
Loop Antenna	SCHWARZBECK	FMZB1519	1519-047	2020-04-02	2023-04-01
TRILOG Broadband Antenna	SCHWARZBECK	VULB 9163	01111	2019-09-12	2022-09-11
Horn Antenna	Schwarzbeck	BBHA 9120D	1594	2020-12-17	2023-12-16
Software	R&S	EMC32	9.26.0	/	/

*****END OF REPORT *****



ANNEX A: The EUT Appearance

The EUT Appearance is submitted separately.



ANNEX B: Test Setup Photos

The Test Setup Photos is submitted separately.