

RF TEST REPORT

Applicant UAB TELTONIKA TELEMATICS
FCC ID 2A3HUFMM880
Product Fleet Management System
Brand TELTONIKA TELEMATICS
Model FMM880-Q3AB0
Report No. R2408A1081-R3
Issue Date September 12, 2024

Eurofins TA Technology (Shanghai) Co., Ltd. tested the above equipment in accordance with the requirements in **FCC CFR47 Part 2 (2023)/ FCC CFR47 Part 27C (2023)**. The test results show that the equipment tested is capable of demonstrating compliance with the requirements as documented in this report.

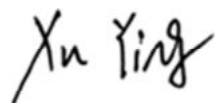

Prepared by: Xu Ying



Approved by: Xu Kai

Eurofins TA Technology (Shanghai) Co., Ltd.

Building 3, No.145, Jintang Rd, Pudong Shanghai, P.R.China

TEL: +86-021-50791141/2/3

FAX: +86-021-50791141/2/3-8000

TABLE OF CONTENT

1	Test Laboratory	4
1.1	Notes of the Test Report.....	4
1.2.	Test facility	4
1.3	Testing Location.....	4
2	General Description of Equipment under Test	5
2.1	Applicant and Manufacturer Information	5
2.2	General information	5
3	Applied Standards	7
4	Test Configuration	8
5	Test Case	9
5.1	RF Power Output and Effective Isotropic Radiated Power	9
5.2	Radiated Spurious Emission	11
6	Test Results	14
6.1	RF Power Output and Effective Isotropic Radiated Power	14
6.2	Radiated Spurious Emission	18
7	Main Test Instruments	25
ANNEX A: The EUT Appearance		26
ANNEX B: Test Setup Photos		27

Summary of Measurement Results

Number	Test Case	Clause in FCC rules	Verdict
1	RF Power Output and Effective Isotropic Radiated Power	2.1046 /27.50(d)(4) /27.50(b)(10) /27.50(c)(10)	PASS
2	Radiated Spurious Emission	2.1053 /27.53(h) /27.53(g) /27.53(f) /27.53(c)	PASS
Date of Testing: August 28, 2024 ~ August 31, 2024			
Date of Sample Received: August 12, 2024			
<p>Note: PASS: The EUT complies with the essential requirements in the standard. FAIL: The EUT does not comply with the essential requirements in the standard.</p> <p>All indications of Pass/Fail in this report are opinions expressed by Eurofins TA Technology (Shanghai) Co., Ltd. based on interpretations and/or observations of test results. Measurement Uncertainties were not taken into account and are published for informational purposes only.</p>			

Only Radiated Spurious Emission is tested for FMM880-Q3AB0 in this report, and because of the change of antenna gain, Effective Isotropic Radiated Power also re evaluated. Other test items refer to the Module report (Report No.: R2003A0152-R3V1, FCC ID: XMR201910BG95M3).

1 Test Laboratory

1.1 Notes of the Test Report

This report shall not be reproduced in full or partial, without the written approval of **Eurofins TA Technology (Shanghai) Co., Ltd.** The results documented in this report apply only to the tested sample, under the conditions and modes of operation as described herein. Measurement Uncertainties were not taken into account and are published for informational purposes only. This report is written to support regulatory compliance of the applicable standards stated above.

1.2. Test facility

FCC (Designation number: CN1179, Test Firm Registration Number: 446626)

Eurofins TA Technology (Shanghai) Co., Ltd. has been listed on the US Federal Communications Commission list of test facilities recognized to perform measurements.

A2LA (Certificate Number: 3857.01)

Eurofins TA Technology (Shanghai) Co., Ltd. has been listed by American Association for Laboratory Accreditation to perform measurement.

1.3 Testing Location

Company: Eurofins TA Technology (Shanghai) Co., Ltd.
Address: Building 3, No.145, Jintang Rd, Pudong Shanghai, P.R.China
City: Shanghai
Post code: 201201
Country: P. R. China
Contact: Xu Kai
Telephone: +86-021-50791141/2/3
Fax: +86-021-50791141/2/3-8000
Website: <https://www.eurofins.com/electrical-and-electronics>
E-mail: Kain.Xu@cpt.eurofinscn.com

2 General Description of Equipment under Test

2.1 Applicant and Manufacturer Information

Applicant	UAB TELTONIKA TELEMATICS
Applicant address	Saltoniskiu st. 9B-1, LT-08105, Vilnius, Lithuania
Manufacturer	UAB TELTONIKA TELEMATICS
Manufacturer address	Saltoniskiu st. 9B-1, LT-08105, Vilnius, Lithuania

2.2 General information

EUT Description			
Model	FMM880-Q3AB0		
SN	MPY23IE0X005305		
Hardware Version	FMM880-11		
Software Version	FMB.Ver.03.28.07		
Power Supply	External power supply		
Antenna Type	Internal Antenna		
Antenna Gain	LTE-M Band 4:	0.97 dBi	
	LTE-M Band 12:	1.13 dBi	
	LTE-M Band 13:	1.13 dBi	
	LTE-M Band 66:	0.97 dBi	
	LTE-M Band 85	1.13 dBi	
Test Mode(s)	LTE-M Band 4/12/13/66/85		
Test Modulation	(LTE-M) QPSK, 16QAM;		
LTE Category	M1		
Maximum E.I.R.P./ E.R.P.	LTE-M Band 4:	21.80 dBm	
	LTE-M Band 12:	19.44 dBm	
	LTE-M Band 13:	19.51 dBm	
	LTE-M Band 66:	21.17 dBm	
	LTE-M Band 85	20.38 dBm	
Rated Power Supply Voltage	12V		
Operating Voltage	Minimum: 10V Maximum: 30V		
Operating Temperature	Lowest: -20°C Highest: +85°C		
Operating Frequency Range(s)	Mode	Tx (MHz)	Rx (MHz)
	LTE-M Band 4	1710 ~ 1755	2110 ~ 2155
	LTE-M Band 12	699 ~ 716	729 ~ 746
	LTE-M Band 13	777 ~ 787	746 ~ 756
	LTE-M Band 66	1710 ~ 1780	2110 ~ 2180

	LTE-M Band 85	698~716	728~746
Note: 1. The EUT is sent from the applicant to Eurofins TA and the information of the EUT is declared by the applicant.			

3 Applied Standards

According to the specifications of the manufacturer, it must comply with the requirements of the following standards:

Test standards:

FCC CFR47 Part 27C (2023)

FCC CFR47 Part 2 (2023)

Reference standard:

ANSI C63.26-2015

KDB 971168 D01 Power Meas License Digital Systems v03r01

4 Test Configuration

Radiated measurements are performed by rotating the EUT in three different orthogonal test planes. EUT stand-up position (Z axis), lie-down position (X, Y axis). Receiver antenna polarization (horizontal and vertical), the worst emission was found in position (Y axis, horizontal polarization) and the worst case was recorded.

All mode and data rates and positions and RB size and modulations were investigated.

Subsequently, only the worst case emissions are reported.

The following testing in different Bandwidth is set to detail in the following table:

Test modes are chosen to be reported as the worst case configuration below for LTE-M Band 4/12/13/66/85:

Test items	Modes	Bandwidth (MHz)						Modulation		RB			Test Channel			
		1.4	3	5	10	15	20	QPSK	16QAM	1	50%	100%	L	M	H	
RF Power Output and Effective Isotropic Radiated Power	LTE-M 4	O	O	O	O	O	O	O	O	O	O	O	O	O	O	O
	LTE-M 12	O	O	O	O	-	-	O	O	O	O	O	O	O	O	O
	LTE-M 13	-	-	O	O	-	-	O	O	O	O	O	O	O	O	O
	LTE-M 66	O	O	O	O	O	O	O	O	O	O	O	O	O	O	O
	LTE-M 85	-	-	O	O	-	-	O	O	O	O	O	O	O	O	O
Radiated Spurious Emission	LTE-M 4	O	-	O	-	-	O	O	-	O	-	-	-	O	-	-
	LTE-M 12	O	-	O	O	-	-	O	-	O	-	-	-	O	-	-
	LTE-M 13	-	-	O	O	-	-	O	-	O	-	-	-	O	-	-
	LTE-M 66	O	-	O	-	-	O	O	-	O	-	-	-	O	-	-
	LTE-M 85	-	-	O	O	-	-	O	-	O	-	-	-	O	-	-
Note	1. The mark "O" means that this configuration is chosen for testing. 2. The mark "-" means that this configuration is not testing.															

5 Test Case

5.1 RF Power Output and Effective Isotropic Radiated Power

Ambient condition

Temperature	Relative humidity	Pressure
15°C ~ 35°C	20% ~ 80%	86 kPa ~ 106 kPa

Methods of Measurement

During the process of the testing, The EUT was connected to the Base Station Simulator with a known loss. The EUT is controlled by the Base Station Simulator test set to ensure max power transmission with proper modulation.

ERP can then be calculated as follows:

$$\text{EIRP (dBm)} = \text{Output Power (dBm)} + \text{Antenna Gain (dBi)}$$

$$\text{EIRP (dBm)} = \text{ERP (dBm)} + 2.15 \text{ (dB.)}$$

Test Setup

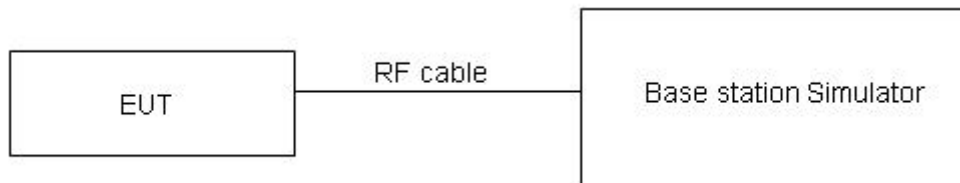

Limits

No specific RF power output requirements in part 2.1046.

Rule Part 27.50(b) (10) specifies that “Portable stations (hand-held devices) transmitting in the 746-757 MHz, 776-788 MHz, and 805-806 MHz bands are limited to 3 watts ERP”

Rule Part 27.50(c) (10) specifies that “Portable stations (hand-held devices) in the 600 MHz uplink band and the 698-746 MHz band, and fixed and mobile stations in the 600 MHz uplink band are limited to 3 watts ERP”

Rule Part 27.50(d) (4) specifies that “Fixed, mobile and portable (hand-held) stations operating in the 1710–1755 MHz band are limited to 1 watt EIRP”

Part 27.50(b)(10)Limit	≤ 3 W (34.77 dBm)
Part 27.50(c)(10)Limit	≤ 3 W (34.77 dBm)
Part 27.50(d)(4)Limit	≤ 1 W (30 dBm)

Measurement Uncertainty

The assessed measurement uncertainty to ensure 95% confidence level for the normal distribution is with the coverage factor $k = 2$, $U=0.4$ dB for RF power output, $k = 2$, $U= 1.19$ dB for ERP/EIRP.

Test Results

Refer to the section 6.1 of this report for test data.

5.2 Radiated Spurious Emission

Ambient condition

Temperature	Relative humidity	Pressure
15°C ~ 35°C	20% ~ 80%	86 kPa ~ 106 kPa

Method of Measurement

- The testing follows FCC KDB 971168 D01 v03r01 Section 5.8 and ANSI C63.26-2015.
- Below 1GHz: The EUT is placed on a turntable 0.8 meters above the ground in the chamber, 3 meter away from the antenna. The maximal emission value is acquired by adjusting the antenna height, polarisation and turntable azimuth. Normally, the height range of antenna is 1 m to 4 m, the azimuth range of turntable is 0° to 360°, and the receive antenna has two polarizations Vertical (V) and Horizontal (H). Above 1GHz: (Note: the FCC's permission to use 1.5m as an alternative per TCBC Conf call of Dec. 2, 2014.) The EUT is placed on a turntable 1.5 meters above the ground in the chamber, 3 meter away from the antenna. The maximal emission value is acquired by adjusting the antenna height, polarisation and turntable azimuth. Normally, the height range of antenna is 1 m to 4 m, the azimuth range of turntable is 0° to 360°, and the receive antenna has two polarizations Vertical (V) and Horizontal (H).
- A loop antenna, A log-periodic antenna or horn antenna shall be substituted in place of the EUT. The log-periodic antenna will be driven by a signal generator and the level will be adjusted till the same power value on the spectrum analyzer or receiver. The level of the spurious emissions can be calculated through the level of the signal generator, cable loss, the gain of the substitution antenna and the reading of the spectrum analyzer or receiver.
- The EUT is then put into continuously transmitting mode at its maximum power level during the test. Set Test Receiver or Spectrum RBW=100kHz, VBW=300kHz for 30MHz to 1GHz and RBW=1MHz, VBW=3MHz for above 1GHz, and the maximum value of the receiver should be recorded as (Pr).
- The EUT shall be replaced by a substitution antenna. In the chamber, an substitution antenna for the frequency band of interest is placed at the reference point of the chamber. An RF Signal source for the frequency band of interest is connected to the substitution antenna with a cable that has been constructed to not interfere with the radiation pattern of the antenna. A power (PMea) is applied to the input of the substitution antenna, and adjust the level of the signal generator output until the value of the receiver reach the previously recorded (Pr). The power of signal source (PMea) is recorded. The test should be performed by rotating the test item and adjusting the receiving antenna polarization.
- A amplifier should be connected to the Signal Source output port. And the cable should be connect between the Amplifier and the Substitution Antenna. The cable loss (Pcl) ,the Substitution Antenna Gain (Ga) and the Amplifier Gain (PAg) should be recorded after test.
- The measurement results are obtained as described below:

$$\text{Power(EIRP)} = \text{PMea} - \text{PAg} - \text{Pcl} + \text{Ga}$$
 The measurement results are amend as described below:

$$\text{Power(EIRP)} = \text{PMea} - \text{Pcl} + \text{Ga}$$
- This value is EIRP since the measurement is calibrated using an antenna of known gain (2.15 dB) and known input power. ERP can be calculated from EIRP by subtracting the gain of the dipole, ERP = EIRP-2.15dB.

The modulation mode and RB allocation refer to section 5.1, using the maximum output power configuration.

Test setup

9KHz~ 30MHz

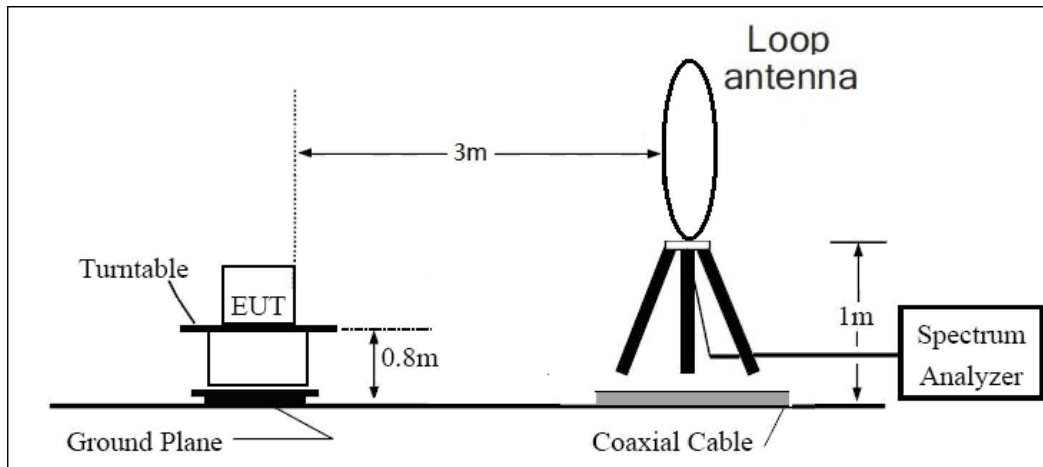

30MHz~ 1GHz

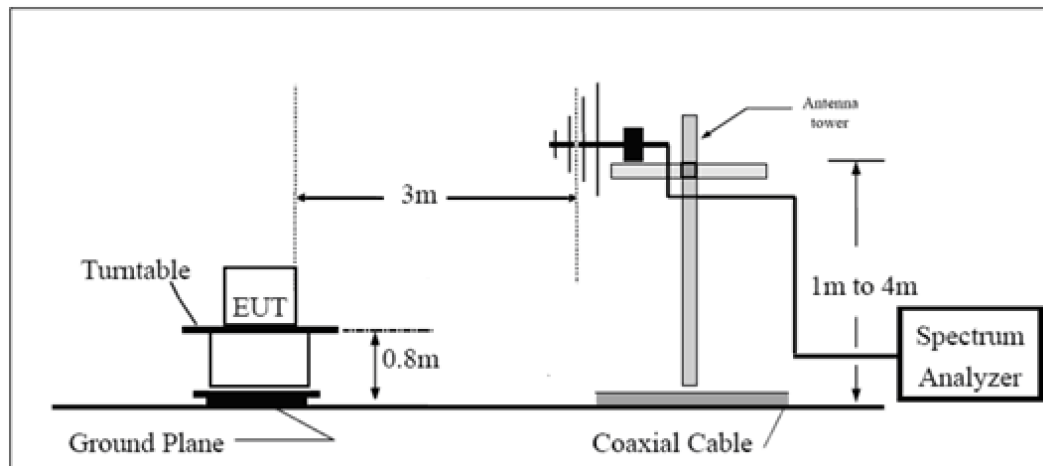

Above 1GHz

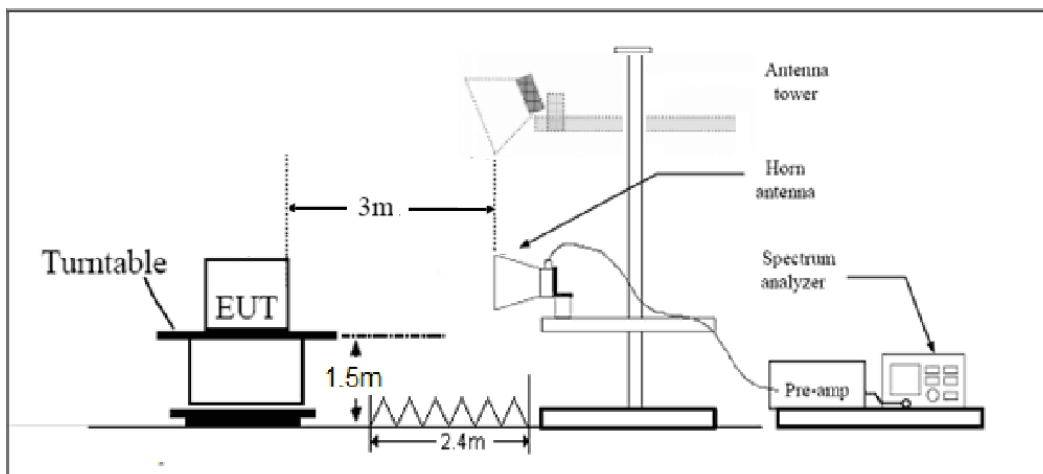

Note: Area side:2.4mX3.6m

Limits

Rule Part 27.53(h) specifies that “for operations in the 1695-1710 MHz, 1710-1755 MHz, 1755-1780 MHz, 1915-1920 MHz, 1995-2000 MHz, 2000-2020 MHz, 2110-2155 MHz, 2155-2180 MHz, and 2180-2200 bands, the power of any emission outside a licensee's frequency block shall be attenuated below the transmitter power (P) in watts by at least $43 + 10 \log_{10}(P)$ dB.”

Rule Part 27.53 (g) For operations in the 600 MHz band and the 698-746 MHz band, the power of any emission outside a licensee's frequency band(s) of operation shall be attenuated below the transmitter power (P) within the licensed band(s) of operation, measured in watts, by at least $43 + 10 \log(P)$ dB. Compliance with this provision is based on the use of measurement instrumentation employing a resolution bandwidth of 100 kilohertz or greater. However, in the 100 kilohertz bands immediately outside and adjacent to a licensee's frequency block, a resolution bandwidth of at least 30 kHz may be employed.

Rule Part 27.53(f) For operations in the 746-758 MHz, 775-788 MHz, and 805-806 MHz bands, emissions in the band 1559-1610 MHz shall be limited to -70 dBW/MHz equivalent isotropically radiated power (EIRP) for wideband signals, and -80 dBW EIRP for discrete emissions of less than 700 Hz bandwidth. For the purpose of equipment authorization, a transmitter shall be tested with an antenna that is representative of the type that will be used with the equipment in normal operation.

Part 27.53 (c) For operations in the 746-758 MHz band and the 776-788 MHz band, the power of any emission outside the licensee's frequency band(s) of operation shall be attenuated below the transmitter power (P) within the licensed band(s) of operation, measured in watts, in accordance with the following:

- (1) On any frequency outside the 746-758 MHz band, the power of any emission shall be attenuated outside the band below the transmitter power (P) by at least $43 + 10 \log(P)$ dB;
- (2) On any frequency outside the 776-788 MHz band, the power of any emission shall be attenuated outside the band below the transmitter power (P) by at least $43 + 10 \log(P)$ dB;
- (3) On all frequencies between 763-775 MHz and 793-805 MHz, by a factor not less than $76 + 10 \log(P)$ dB in a 6.25 kHz band segment, for base and fixed stations;
- (4) On all frequencies between 763-775 MHz and 793-805 MHz, by a factor not less than $65 + 10 \log(P)$ dB in a 6.25 kHz band segment, for mobile and portable stations;
- (5) Compliance with the provisions of paragraphs (c)(1) and (c)(2) of this section is based on the use of measurement instrumentation employing a resolution bandwidth of 100 kHz or greater. However, in the 100 kHz bands immediately outside and adjacent to the frequency block, a resolution bandwidth of at least 30 kHz may be employed;

Part 27.53 (h)/(g) Limit		-13 dBm
Part 27.53(f) Limit	Limit out of the band 1559-1610 MHz	-13 dBm
	Limit in the band 1559-1610 MHz	-40 dBm

Measurement Uncertainty

The assessed measurement uncertainty to ensure 95% confidence level for the normal distribution is with the coverage factor $k = \pm 1.96$, $U = \pm 3.55$ dB.

Test Results

Refer to the section 6.2 of this report for test data.

6 Test Results

6.1 RF Power Output and Effective Isotropic Radiated Power

LTE-M Band 4	Channel/ Frequency(MHz)	Index	RB# RBstart	Conducted Power (dBm)		EIRP (dBm)	
				QPSK	16QAM	QPSK	16QAM
1.4MHz	19957/1710.7	0	1#0	20.83	19.76	21.80	20.73
		0	6#0	18.78	19.04	19.75	20.01
	20175/1732.5	0	1#0	20.57	19.62	21.54	20.59
		0	6#0	18.52	18.54	19.49	19.51
	20393/1754.3	0	1#5	19.92	19.75	20.89	20.72
		0	6#0	18.63	18.48	19.60	19.45
3MHz	19965/1711.5	0	1#0	20.41	20.02	21.38	20.99
		0	6#0	18.71	18.78	19.68	19.75
	20175/1732.5	0	1#0	20.32	19.37	21.29	20.34
		0	6#0	18.71	18.94	19.68	19.91
	20385/1753.5	1	1#5	20.15	19.15	21.12	20.12
		1	6#0	18.81	19.01	19.78	19.98
5MHz	19975/1712.5	0	1#0	20.39	20.51	21.36	21.48
		0	6#0	19.81	19.91	20.78	20.88
	20175/1732.5	0	1#0	20.28	20.39	21.25	21.36
		0	6#0	19.73	19.67	20.70	20.64
	20375/1752.5	3	1#5	20.11	20.17	21.08	21.14
		3	6#0	19.72	19.69	20.69	20.66
10MHz	20000/1715	0	1#0	20.38	20.49	21.35	21.46
		0	4#0	20.27	20.14	21.24	21.11
	20175/1732.5	0	1#0	20.16	20.24	21.13	21.21
		0	4#0	20.12	19.98	21.09	20.95
	20350/1750	7	1#5	19.94	20.07	20.91	21.04
		7	4#2	20.04	19.91	21.01	20.88
15MHz	20025/1717.5	0	1#0	20.33	20.48	21.30	21.45
		0	6#0	20.27	20.42	21.24	21.39
	20175/1732.5	0	1#0	20.16	20.31	21.13	21.28
		0	6#0	20.12	20.24	21.09	21.21
	20325/1747.5	11	1#5	19.97	20.11	20.94	21.08
		11	6#0	20.04	20.11	21.01	21.08
20MHz	20050/1720	0	1#0	20.32	20.46	21.29	21.43
		0	6#0	20.19	20.36	21.16	21.33
	20175/1732.5	0	1#0	20.24	20.38	21.21	21.35
		0	6#0	20.09	20.21	21.06	21.18

	20300/1745	15	1#5	20.11	20.14	21.08	21.11
		15	6#0	20.11	20.16	21.08	21.13

LTE-M Band 12	Channel/ Frequency(MHz)	Index	RB# RBstart	Conducted Power (dBm)		ERP (dBm)	
				QPSK	16QAM	QPSK	16QAM
1.4MHz	23017/699.7	0	1#0	20.02	19.76	19.00	18.74
		0	6#0	18.64	18.62	17.62	17.60
	23095/707.5	0	1#0	19.85	19.73	18.83	18.71
		0	6#0	18.51	18.42	17.49	17.40
	23173/715.3	0	1#5	20.46	19.32	19.44	18.30
		0	6#0	18.56	19.03	17.54	18.01
3MHz	23025/700.5	0	1#0	20.25	19.76	19.23	18.74
		0	6#0	18.69	18.61	17.67	17.59
	23095/707.5	0	1#0	20.22	20.01	19.20	18.99
		0	6#0	18.47	18.58	17.45	17.56
	23165/714.5	1	1#5	20.21	19.81	19.19	18.79
		1	6#0	18.55	18.63	17.53	17.61
5MHz	23035/701.5	3	1#0	20.19	20.39	19.17	19.37
		0	6#0	19.67	19.82	18.65	18.80
	23095/707.5	0	1#0	20.01	20.21	18.99	19.19
		0	6#0	19.60	19.73	18.58	18.71
	23155/713.5	0	1#5	19.96	20.19	18.94	19.17
		3	6#0	19.61	19.77	18.59	18.75
10MHz	23060/704	3	1#0	20.21	20.41	19.19	19.39
		0	4#0	20.23	20.07	19.21	19.05
	23095/707.5	0	1#0	20.16	20.30	19.14	19.28
		0	4#0	20.07	19.95	19.05	18.93
	23130/711	4	1#5	19.91	20.13	18.89	19.11
		7	4#2	20.15	19.90	19.13	18.88

LTE-M Band 13	Channel/ Frequency(MHz)	Index	RB# RBstart	Conducted Power (dBm)		ERP (dBm)	
				QPSK	16QAM	QPSK	16QAM
5MHz	23205/779.5	0	1#0	20.18	20.53	19.16	19.51
		0	6#0	19.95	20.03	18.93	19.01
	23230/782	0	1#0	20.31	19.91	19.29	18.89
		0	6#0	19.81	20.02	18.79	19.00
	23255/784.5	3	1#5	20.02	20.43	19.00	19.41
		3	6#0	19.82	19.84	18.80	18.82
10MHz	23230/782	0	1#0	20.11	20.53	19.09	19.51
		0	4#0	19.84	19.57	18.82	18.55

LTE-M Band 66	Channel/ Frequency(MHz)	Index	RB# RBstart	Conducted Power (dBm)		EIRP (dBm)	
				QPSK	16QAM	QPSK	16QAM
1.4MHz	131979/1710.7	0	1#0	20.18	19.66	21.15	20.63
		0	6#0	18.38	18.49	19.35	19.46
	132322/1745	0	1#0	19.80	19.47	20.77	20.44
		0	6#0	18.34	18.08	19.31	19.05
	132665/1779.3	0	1#5	19.61	19.78	20.58	20.75
		0	6#0	18.50	18.33	19.47	19.30
3MHz	131987/1711.5	0	1#0	19.97	19.57	20.94	20.54
		0	6#0	18.32	18.25	19.29	19.22
	132322/1745	0	1#0	19.80	19.55	20.77	20.52
		0	6#0	18.20	18.12	19.17	19.09
	132657/1778.5	1	1#5	19.84	19.69	20.81	20.66
		1	6#0	18.52	18.35	19.49	19.32
5MHz	131997/1712.5	0	1#0	19.89	20.20	20.86	21.17
		0	6#0	19.35	19.36	20.32	20.33
	132322/1745	0	1#0	19.73	20.04	20.70	21.01
		0	6#0	19.18	19.29	20.15	20.26
	132647/1777.5	0	1#5	19.84	20.11	20.81	21.08
		3	6#0	19.55	19.57	20.52	20.54
10MHz	132022/1715	3	1#0	19.95	20.15	20.92	21.12
		0	4#0	19.88	19.79	20.85	20.76
	132022/1745	0	1#0	19.76	19.99	20.73	20.96
		0	4#0	19.83	19.58	20.80	20.55
	132622/1775	4	1#5	19.70	20.02	20.67	20.99
		7	4#2	19.87	19.81	20.84	20.78
15MHz	132047/1717.5	3	1#0	19.92	20.18	20.89	21.15
		0	6#0	19.84	19.87	20.81	20.84
	132322/1745	0	1#0	19.73	20.02	20.70	20.99
		0	6#0	19.79	19.83	20.76	20.80
	132597/1772.5	8	1#5	19.85	20.09	20.82	21.06
		11	6#0	19.94	19.95	20.91	20.92
20MHz	132072/1720	3	1#0	19.90	20.19	20.87	21.16
		0	6#0	19.81	19.94	20.78	20.91
	132322/1745	0	1#0	19.86	20.08	20.83	21.05
		0	6#0	19.82	19.91	20.79	20.88
	132572/1770	12	1#5	19.49	19.65	20.46	20.62
		15	6#0	19.52	19.67	20.49	20.64

LTE-M Band 85	Channel/ Frequency(MHz)	Index	RB# RBstart	Conducted Power (dBm)		ERP (dBm)	
				QPSK	16QAM	QPSK	16QAM
5MHz	134027/700.5	0	1#0	20.70	20.63	19.68	19.61
		0	6#0	20.46	20.54	19.44	19.52
	134092/707	0	1#0	21.18	20.71	20.16	19.69
		0	6#0	20.74	20.70	19.72	19.68
	134157/713.5	3	1#5	21.16	20.64	20.14	19.62
		3	6#0	20.71	20.63	19.69	19.61
10MHz	134052/703	0	1#0	20.91	20.37	19.89	19.35
		0	4#0	20.55	20.74	19.53	19.72
	134092/707	0	1#0	21.15	20.59	20.13	19.57
		0	4#0	21.08	21.29	20.06	20.27
	134132/711	0	1#5	21.28	20.62	20.26	19.60
		0	4#2	21.27	21.40	20.25	20.38

6.2 Radiated Spurious Emission

Sweep the whole frequency band through the range from 9kHz to the 10th harmonic of the carrier, the emissions below the noise floor will not be recorded in the report.

LTE-M Band 4 QPSK 1.4MHz CH-Middle, RB 1

Harmonic	Frequency (MHz)	SG (dBm)	Cable Loss (dB)	Gain (dBi)	Antenna Polarization	Result Level (dBm)	Limit (dBm)	Margin (dB)	Azimuth (deg)
2	3464.30	-75.63	2.70	12.70	Horizontal	-65.63	-13.00	52.63	79
3	5197.50	-76.24	3.20	12.50	Horizontal	-66.94	-13.00	53.94	4
4	6930.00	-71.51	4.20	11.80	Horizontal	-63.91	-13.00	50.91	36
5	8662.50	-66.72	4.40	12.50	Horizontal	-58.62	-13.00	45.62	2
6	10395.00	-61.78	4.70	11.30	Horizontal	-55.18	-13.00	42.18	186
7	12127.50	-64.21	5.20	13.80	Horizontal	-55.61	-13.00	42.61	23
8	13853.60	-57.55	5.70	11.30	Horizontal	-51.95	-13.00	38.95	175
9	15592.50	-68.33	6.10	16.80	Horizontal	-57.63	-13.00	44.63	64
10	17325.00	-62.16	6.10	14.20	Horizontal	-54.06	-13.00	41.06	25

Note: 1. The other Spurious RF Radiated emissions level is no more than noise floor.
2. The worst emission was found in the antenna is Horizontal position.

LTE-M Band 4 QPSK 5MHz CH-Middle, RB 1

Harmonic	Frequency (MHz)	SG (dBm)	Cable Loss (dB)	Gain (dBi)	Antenna Polarization	Result Level (dBm)	Limit (dBm)	Margin (dB)	Azimuth (deg)
2	3460.50	-75.22	2.70	12.70	Horizontal	-65.22	-13.00	52.22	142
3	5191.50	-76.11	3.20	12.50	Horizontal	-66.81	-13.00	53.81	78
4	6930.00	-71.69	4.20	11.80	Horizontal	-64.09	-13.00	51.09	0
5	8662.50	-66.03	4.40	12.50	Horizontal	-57.93	-13.00	44.93	23
6	10380.00	-61.89	4.70	11.30	Horizontal	-55.29	-13.00	42.29	1
7	12110.00	-64.37	5.20	13.80	Horizontal	-55.77	-13.00	42.77	214
8	13840.00	-57.13	5.70	11.30	Horizontal	-51.53	-13.00	38.53	14
9	15570.00	-68.17	6.10	16.80	Horizontal	-57.47	-13.00	44.47	90
10	17300.00	-62.37	6.10	14.20	Horizontal	-54.27	-13.00	41.27	158

Note: 1. The other Spurious RF Radiated emissions level is no more than noise floor.
2. The worst emission was found in the antenna is Horizontal position.

LTE-M Band 4 QPSK 20MHz CH-Middle, RB 1

Harmonic	Frequency (MHz)	SG (dBm)	Cable Loss (dB)	Gain (dBi)	Antenna Polarization	Result Level (dBm)	Limit (dBm)	Margin (dB)	Azimuth (deg)
2	3448.20	-76.07	2.70	12.70	Horizontal	-66.07	-13.00	53.07	142
3	5170.88	-76.13	3.20	12.50	Horizontal	-66.83	-13.00	53.83	23
4	6930.00	-71.63	4.20	11.80	Horizontal	-64.03	-13.00	51.03	3
5	8662.50	-66.56	4.40	12.50	Horizontal	-58.46	-13.00	45.46	76
6	10395.00	-62.09	4.70	11.30	Horizontal	-55.49	-13.00	42.49	17
7	12127.50	-64.20	5.20	13.80	Horizontal	-55.60	-13.00	42.60	176
8	13860.00	-57.64	5.70	11.30	Horizontal	-52.04	-13.00	39.04	1
9	15592.50	-68.59	6.10	16.80	Horizontal	-57.89	-13.00	44.89	23
10	17325.00	-62.76	6.10	14.20	Horizontal	-54.66	-13.00	41.66	86

Note: 1. The other Spurious RF Radiated emissions level is no more than noise floor.

2. The worst emission was found in the antenna is Horizontal position.

LTE-M Band 12 QPSK 1.4MHz CH-Middle, RB 1

Harmonic	Frequency (MHz)	SG (dBm)	Cable Loss (dB)	Gain (dBi)	Antenna Polarization	Result Level (dBm)	Limit (dBm)	Margin (dB)	Azimuth (deg)
2	1413.93	-69.04	1.70	8.70	Horizontal	-64.19	-13.00	51.19	185
3	2120.80	-62.71	2.10	11.10	Horizontal	-55.86	-13.00	42.86	75
4	2828.40	-66.98	2.30	13.10	Horizontal	-58.33	-13.00	45.33	36
5	3537.50	-67.86	2.60	12.70	Horizontal	-59.91	-13.00	46.91	21
6	4245.00	-65.63	3.30	12.50	Horizontal	-58.58	-13.00	45.58	175
7	4952.50	-64.54	3.40	12.50	Horizontal	-57.59	-13.00	44.59	25
8	5660.00	-64.13	3.30	12.50	Horizontal	-57.08	-13.00	44.08	175
9	6367.50	-59.78	3.80	11.50	Horizontal	-54.23	-13.00	41.23	0
10	7075.00	-54.53	4.20	11.80	Horizontal	-49.08	-13.00	36.08	12

Note: 1. The other Spurious RF Radiated emissions level is no more than noise floor.

2. The worst emission was found in the antenna is Horizontal position.

LTE-M Band 12 QPSK 5MHz CH-Middle, RB 1

Harmonic	Frequency (MHz)	SG (dBm)	Cable Loss (dB)	Gain (dBi)	Antenna Polarization	Result Level (dBm)	Limit (dBm)	Margin (dB)	Azimuth (deg)
2	1410.80	-67.77	1.70	8.70	Horizontal	-62.92	-13.00	49.92	2
3	2116.00	-63.18	2.10	11.10	Horizontal	-56.33	-13.00	43.33	78
4	2820.93	-66.79	2.30	13.10	Horizontal	-58.14	-13.00	45.14	125
5	3525.00	-67.05	2.60	12.70	Horizontal	-59.10	-13.00	46.10	28
6	4230.00	-64.71	3.30	12.50	Horizontal	-57.66	-13.00	44.66	69
7	4935.00	-65.20	3.40	12.50	Horizontal	-58.25	-13.00	45.25	14
8	5640.00	-63.53	3.30	12.50	Horizontal	-56.48	-13.00	43.48	135
9	6345.00	-58.46	3.80	11.50	Horizontal	-52.91	-13.00	39.91	2
10	7050.00	-55.28	4.20	11.80	Horizontal	-49.83	-13.00	36.83	76

Note: 1. The other Spurious RF Radiated emissions level is no more than noise floor.
 2. The worst emission was found in the antenna is Horizontal position.

LTE-M Band 12 QPSK 10MHz CH-Middle, RB 1

Harmonic	Frequency (MHz)	SG (dBm)	Cable Loss (dB)	Gain (dBi)	Antenna Polarization	Result Level (dBm)	Limit (dBm)	Margin (dB)	Azimuth (deg)
2	1406.60	-66.49	1.70	8.70	Horizontal	-61.64	-13.00	48.64	12
3	2109.60	-62.39	2.10	11.10	Horizontal	-55.54	-13.00	42.54	23
4	2813.53	-65.50	2.30	13.10	Horizontal	-56.85	-13.00	43.85	75
5	3512.50	-66.96	2.60	12.70	Horizontal	-59.01	-13.00	46.01	41
6	4215.00	-65.23	3.30	12.50	Horizontal	-58.18	-13.00	45.18	135
7	4917.50	-63.66	3.40	12.50	Horizontal	-56.71	-13.00	43.71	25
8	5620.00	-62.77	3.30	12.50	Horizontal	-55.72	-13.00	42.72	38
9	6322.50	-58.55	3.80	11.50	Horizontal	-53.00	-13.00	40.00	175
10	7025.00	-56.41	4.20	11.80	Horizontal	-50.96	-13.00	37.96	0

Note: 1. The other Spurious RF Radiated emissions level is no more than noise floor.
 2. The worst emission was found in the antenna is Horizontal position.

LTE-M Band 13 QPSK 5MHz CH-Middle, RB 1

Harmonic	Frequency (MHz)	SG (dBm)	Cable Loss (dB)	Gain (dBi)	Antenna Polarization	Result Level (dBm)	Limit (dBm)	Margin (dB)	Azimuth (deg)
2	1556.63	-70.94	1.70	8.70	Horizontal	-63.94	-40.00	23.94	152
3	2339.52	-55.41	2.10	12.00	Horizontal	-47.66	-13.00	34.66	17
4	3118.00	-67.87	2.30	13.10	Horizontal	-59.22	-13.00	46.22	56
5	3897.50	-65.06	2.90	12.50	Horizontal	-57.61	-13.00	44.61	178
6	4677.00	-65.35	3.10	12.50	Horizontal	-58.10	-13.00	45.10	12
7	5456.50	-62.23	3.30	12.50	Horizontal	-55.18	-13.00	42.18	26
8	6236.00	-60.41	3.50	12.80	Horizontal	-53.26	-13.00	40.26	76
9	7015.50	-55.56	4.20	11.80	Horizontal	-50.11	-13.00	37.11	123
10	7795.00	-56.44	4.40	12.30	Horizontal	-50.69	-13.00	37.69	28

Note: 1. The other Spurious RF Radiated emissions level is no more than noise floor.
 2. The worst emission was found in the antenna is Horizontal position.

LTE-M Band 13 QPSK 10MHz CH-Middle, RB 1

Harmonic	Frequency (MHz)	SG (dBm)	Cable Loss (dB)	Gain (dBi)	Antenna Polarization	Result Level (dBm)	Limit (dBm)	Margin (dB)	Azimuth (deg)
2	1574.45	-80.10	1.70	8.70	Horizontal	-73.10	-40.00	33.10	287
3	2333.22	-56.59	2.10	12.00	Horizontal	-48.84	-13.00	35.84	78
4	3108.00	-67.41	2.30	13.10	Horizontal	-58.76	-13.00	45.76	186
5	3885.00	-65.88	2.90	12.50	Horizontal	-58.43	-13.00	45.43	17
6	4662.00	-65.51	3.10	12.50	Horizontal	-58.26	-13.00	45.26	46
7	5439.00	-64.15	3.30	12.50	Horizontal	-57.10	-13.00	44.10	38
8	6216.00	-65.64	3.50	12.80	Horizontal	-58.49	-13.00	45.49	37
9	6993.00	-60.09	4.20	11.80	Horizontal	-54.64	-13.00	41.64	175
10	7770.00	-55.63	4.40	12.30	Horizontal	-49.88	-13.00	36.88	26

Note: 1. The other Spurious RF Radiated emissions level is no more than noise floor.
 2. The worst emission was found in the antenna is Horizontal position.

LTE-M Band 66 QPSK 1.4MHz CH-Middle, RB 1

Harmonic	Frequency (MHz)	SG (dBm)	Cable Loss (dB)	Gain (dBi)	Antenna Polarization	Result Level (dBm)	Limit (dBm)	Margin (dB)	Azimuth (deg)
2	3488.60	-76.73	2.70	12.70	Horizontal	-66.73	-13.00	53.73	3
3	5232.90	-68.49	3.20	12.50	Horizontal	-59.19	-13.00	46.19	25
4	6977.20	-71.56	4.20	11.80	Horizontal	-63.96	-13.00	50.96	196
5	8721.50	-66.99	4.40	12.50	Horizontal	-58.89	-13.00	45.89	25
6	10465.80	-63.06	4.70	11.80	Horizontal	-55.96	-13.00	42.96	241
7	12210.10	-63.41	5.20	13.80	Horizontal	-54.81	-13.00	41.81	26
8	13954.40	-60.44	5.70	13.20	Horizontal	-52.94	-13.00	39.94	23
9	15698.70	-68.20	6.10	16.80	Horizontal	-57.50	-13.00	44.50	175
10	17443.00	-63.35	6.10	14.20	Horizontal	-55.25	-13.00	42.25	14

Note: 1. The other Spurious RF Radiated emissions level is no more than noise floor.
 2. The worst emission was found in the antenna is Horizontal position.

LTE-M Band 66 QPSK 5MHz CH-Middle, RB 1

Harmonic	Frequency (MHz)	SG (dBm)	Cable Loss (dB)	Gain (dBi)	Antenna Polarization	Result Level (dBm)	Limit (dBm)	Margin (dB)	Azimuth (deg)
2	3486.00	-77.59	2.70	12.70	Horizontal	-67.59	-13.00	54.59	2
3	5229.00	-67.05	3.20	12.50	Horizontal	-57.75	-13.00	44.75	24
4	6972.00	-71.76	4.20	11.80	Horizontal	-64.16	-13.00	51.16	246
5	8715.00	-66.30	4.40	12.50	Horizontal	-58.20	-13.00	45.20	142
6	10458.00	-62.66	4.70	11.80	Horizontal	-55.56	-13.00	42.56	26
7	12201.00	-63.42	5.20	13.80	Horizontal	-54.82	-13.00	41.82	3
8	13944.00	-60.56	5.70	13.20	Horizontal	-53.06	-13.00	40.06	76
9	15687.00	-67.70	6.10	16.80	Horizontal	-57.00	-13.00	44.00	143
10	17430.00	-63.14	6.10	14.20	Horizontal	-55.04	-13.00	42.04	25

Note: 1. The other Spurious RF Radiated emissions level is no more than noise floor.
 2. The worst emission was found in the antenna is Horizontal position.

LTE-M Band 66 QPSK 20MHz CH-Middle, RB 1

Harmonic	Frequency (MHz)	SG (dBm)	Cable Loss (dB)	Gain (dBi)	Antenna Polarization	Result Level (dBm)	Limit (dBm)	Margin (dB)	Azimuth (deg)
2	3472.88	-77.10	2.70	12.70	Horizontal	-67.10	-13.00	54.10	12
3	5209.00	-66.15	3.20	12.50	Horizontal	-56.85	-13.00	43.85	135
4	6945.75	-71.43	4.20	11.80	Horizontal	-63.83	-13.00	50.83	2
5	8682.00	-66.64	4.40	12.50	Horizontal	-58.54	-13.00	45.54	68
6	10418.63	-62.29	4.70	11.80	Horizontal	-55.19	-13.00	42.19	79
7	12455.00	-64.83	5.20	13.80	Horizontal	-56.23	-13.00	43.23	142
8	13891.50	-60.35	5.70	13.20	Horizontal	-52.85	-13.00	39.85	21
9	15627.00	-68.06	6.10	16.80	Horizontal	-57.36	-13.00	44.36	95
10	17364.38	-62.40	6.10	14.20	Horizontal	-54.30	-13.00	41.30	25

Note: 1. The other Spurious RF Radiated emissions level is no more than noise floor.
 2. The worst emission was found in the antenna is Horizontal position.

LTE-M Band 85 QPSK 5MHz CH-Middle, RB 1

Harmonic	Frequency (MHz)	SG (dBm)	Cable Loss (dB)	Gain (dBi)	Antenna Polarization	Result Level (dBm)	Limit (dBm)	Margin (dB)	Azimuth (deg)
2	1409.00	-69.63	1.70	8.70	Horizontal	-64.78	-13.00	51.78	2
3	2114.40	-59.40	2.10	11.10	Horizontal	-52.55	-13.00	39.55	78
4	2819.33	-65.26	2.30	13.10	Horizontal	-56.61	-13.00	43.61	125
5	3490.00	-66.80	2.60	12.70	Horizontal	-58.85	-13.00	45.85	21
6	4188.00	-65.08	3.30	12.50	Horizontal	-58.03	-13.00	45.03	175
7	4886.00	-63.99	3.40	12.50	Horizontal	-57.04	-13.00	44.04	25
8	5584.00	-62.82	3.30	12.50	Horizontal	-55.77	-13.00	42.77	175
9	6282.00	-59.24	3.80	11.50	Horizontal	-53.69	-13.00	40.69	0
10	6980.00	-59.48	4.20	11.80	Horizontal	-54.03	-13.00	41.03	12

Note: 1. The other Spurious RF Radiated emissions level is no more than noise floor.
 2. The worst emission was found in the antenna is Horizontal position.

LTE-M Band 85 QPSK 10MHz CH-Middle, RB 1

Harmonic	Frequency (MHz)	SG (dBm)	Cable Loss (dB)	Gain (dBi)	Antenna Polarization	Result Level (dBm)	Limit (dBm)	Margin (dB)	Azimuth (deg)
2	1404.00	-68.95	1.70	8.70	Horizontal	-64.10	-13.00	51.10	12
3	2108.27	-58.22	2.10	11.10	Horizontal	-51.37	-13.00	38.37	23
4	2810.27	-65.60	2.30	13.10	Horizontal	-56.95	-13.00	43.95	75
5	3510.00	-66.35	2.60	12.70	Horizontal	-58.40	-13.00	45.40	28
6	4212.00	-64.83	3.30	12.50	Horizontal	-57.78	-13.00	44.78	69
7	4914.00	-64.83	3.40	12.50	Horizontal	-57.88	-13.00	44.88	14
8	5616.00	-62.05	3.30	12.50	Horizontal	-55.00	-13.00	42.00	135
9	6318.00	-58.82	3.80	11.50	Horizontal	-53.27	-13.00	40.27	2
10	7020.00	-55.65	4.20	11.80	Horizontal	-50.20	-13.00	37.20	76

Note: 1. The other Spurious RF Radiated emissions level is no more than noise floor.

2. The worst emission was found in the antenna is Horizontal position.

7 Main Test Instruments

Name	Manufacturer	Type	Serial Number	Calibration Date	Expiration Date
Spectrum Analyzer	R&S	FSV30	104028	2024-05-07	2025-05-06
TRILOG Broadband Antenna	SCHWARZBECK	VULB 9163	1439	2024-07-06	2027-07-05
Horn Antenna	SCHWARZBECK	BBHA 9120D	01799	2022-09-01	2025-08-31
Software	R&S	EMC32	10.35.10	/	/

ANNEX A: The EUT Appearance

The EUT Appearance are submitted separately.

ANNEX B: Test Setup Photos

The Test Setup Photos are submitted separately.

***** END OF REPORT *****