

**Wi-Fi Connected Smart Pellet Grill
with Touch Screen**

Model
910-05005
SKU
085-0219-0

User Manual

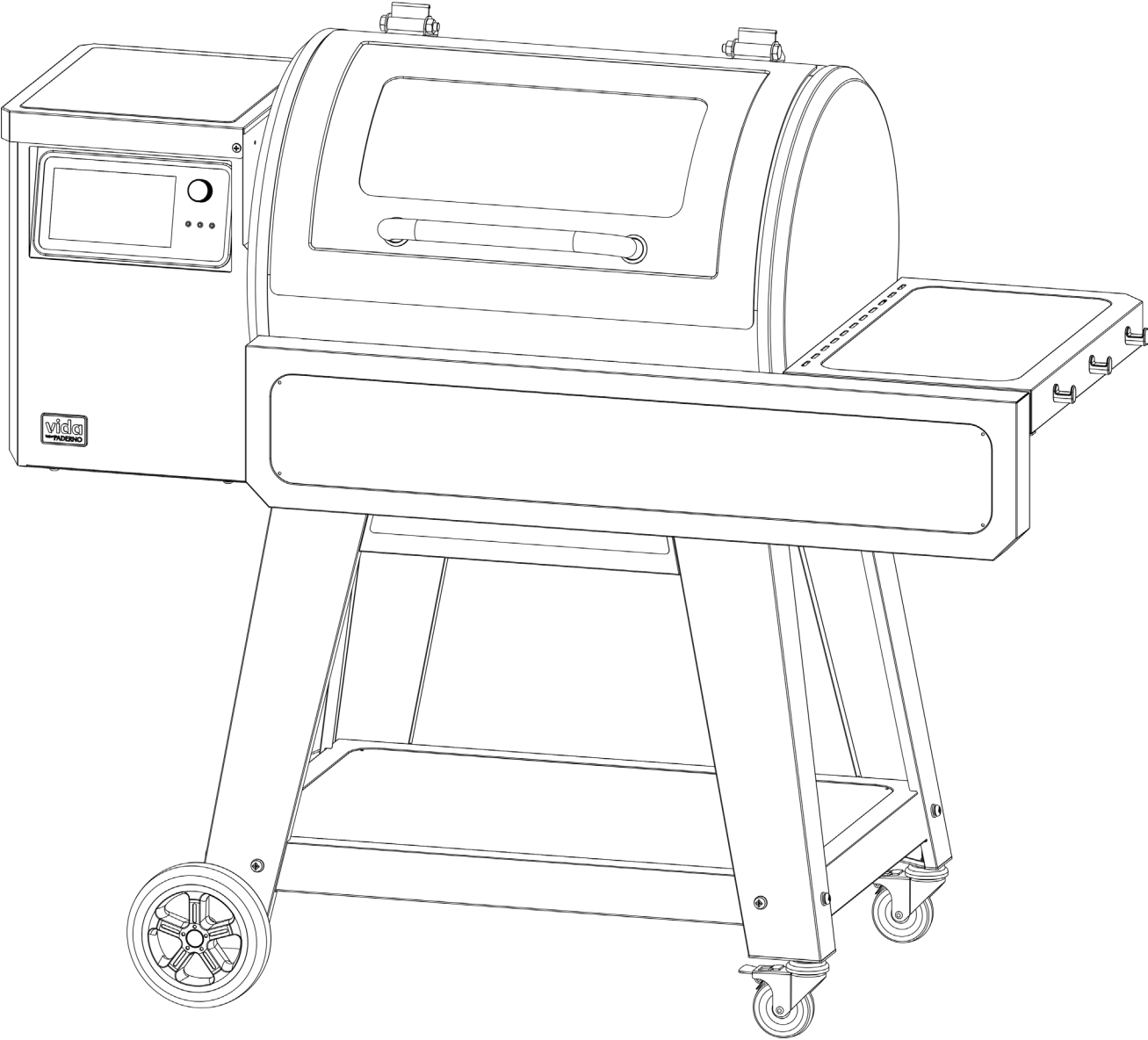

vidaTM
by PADERNO

Table of Contents

Safety	Safety Warnings	3
Assembly	Package Parts List	5
	Assembly Instructions	8
Setup	Controller Guide	18
	App Guide	23
	Setup Instructions	24
Use and Maintenance	Lighting Instructions	25
	Operating Instructions	26
	Care and Maintenance	27
	Storage	27
	Troubleshooting	28
Warranty	Limited Warranty	29
	Service	30
	Electrical Diagram	31
	Parts List	32

- **This instruction manual contains important information necessary for the proper assembly and safe use of the appliance.**
- **Please read this entire manual before installation and use of this pellet fuel-burning appliance. Failure to follow these instructions could result in property damage, bodily injury or even death.**
- **Follow all warnings and instructions when using the appliance.**
- **Save these instructions.**
- **Not for commercial use.**
- **Contact local building or fire officials about restrictions and installation inspection requirements in your area.**

FOR OUTDOOR USE ONLY

Safety Warnings

WARNING! Follow these guidelines to prevent this colorless, odorless gas from poisoning you, your family or others:

- Know the symptoms of carbon monoxide poisoning: headache, dizziness, weakness, nausea, vomiting, sleepiness, and confusion. Carbon monoxide reduces the blood’s ability to carry oxygen. Low blood oxygen levels can result in loss of consciousness and death.
- See a doctor if you and others develop cold or flu-like symptoms while cooking or in the vicinity of this appliance. Carbon monoxide poisoning, which can easily be mistaken for cold or flu, is often detected too late.
- Alcohol consumption and drug use increase the effects of carbon monoxide poisoning.

Carbon monoxide is especially toxic to mother and child during pregnancy, infants, the elderly, smokers, and people with blood or circulatory system problems, such as anemia, or heart disease.

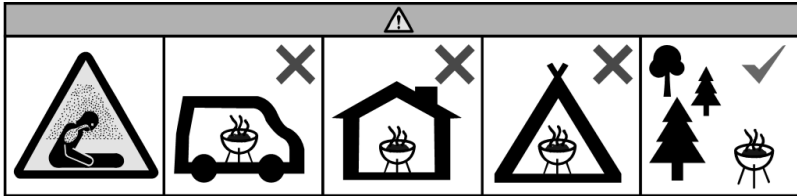

WARNING! Do not use the barbecue in a confined and/or habitable space, e.g., houses, tents, caravans, motor homes, boats. Danger of carbon monoxide poisoning fatality.

WARNING! If fire occurs:

- Keep away from the appliance and immediately call your local fire department.
- Do not try to move appliance, smother fire, or put water on the fire.
- Keep the appliance clean – refer to the Care and Maintenance Instructions.

CAUTION! Never use gasoline, gasoline-type lantern fuel, kerosene, charcoal lighter fluid, or similar liquids to start or ‘freshen up’ a fire in this appliance. Keep all such liquids well away from the appliance when in use.

WARNING!

- Do not use heating grade pellets. Use only cooking grade pellets manufactured of 100% natural wood that is intended for pellet grill usage.
- Do not use pellet fuel labelled as having additives.
- Never put wood chips or chunks into the hopper.
- Only use dry pellets. If the grill was stored with the hopper full, check the pellets to ensure that they are completely dry before use. Hardwood pellets can absorb moisture in wet or humid environments, causing them to expand and possibly obstruct or jam the auger system.
- Never allow the hopper to empty while the grill is in operation. Make sure to fill the pellet hopper with enough pellets before use or refill the pellet hopper as necessary.

Safety Warnings

SAFETY PRACTICES TO AVOID INJURY

When properly cared for, your grill will provide safe and reliable service for many years. However, extreme care must be used as the grill produces intense heat that has a potential to cause injury when misused. When using this appliance, basic safety practices must be followed, including the following:

- Do not repair or replace any part of the grill unless specifically recommended in this manual. All other service should be referred to a qualified technician.
- This outdoor cooking appliance is not intended to be installed in or on boats and other recreational vehicles.
- Do not use this grill under any overhead combustible construction including ceilings or overhangs.
- **WARNING!** Keep children and pets away. Children should not be left alone or unattended in an area where the grill is being used. Do not allow them to sit, stand or play in or around the grill at any time.
- Do not store items of interest to children around or below the grill.
- For personal safety, wear proper apparel. Loose fitting garments or sleeves should never be worn while using this appliance. Some synthetic fabrics are highly flammable and **should not** be worn while cooking.
- Always use heat-resistant gloves or mitts when handling particularly hot components. When using the grill, do not touch the warming rack, burner grate or immediate surroundings as these areas become extremely hot and could cause burns. Use only dry potholders. Moist or damp potholders on hot surfaces may cause steam burns. Do not use a towel or bulky cloth in place of potholders. Do not allow potholders to touch hot portions of the grill rack.
- Only certain types of glass, heat-proof glass ceramic, earthenware, or other glazed utensils are suitable for grill use. These materials may break with sudden temperature changes. Use only on low or medium heat settings in accordance with the manufacturer's guidelines.
- Do not heat unopened food containers. A build-up of pressure may cause the containers to burst.
- Never lean over an open grill.
- Grease is flammable. Let hot grease cool before attempting to handle it. Clean out the grease tray and grease bucket often to avoid build-up.
- Do not use water to control flare ups or extinguish the fire. Turn off the grill, unplug the power cord, and wait for the grill to cool down.
- Always have the grease system properly installed while operating this grill. Never operate without the grease tray and grease pan installed.
- Dispose of ashes after the grill has completely cooled following a proper shutdown. Wait until grease and ash are completely cooled before disposing.
- Wait until the fuel is extinguished and the grill is completely cool before moving, covering, or storing the grill.
- Do not use aluminum foil to line the grill racks or grill bottom. This can severely upset combustion airflow or trap excessive heat in the control area.
- Clean the grill with caution. To avoid steam burns, do not use a wet sponge or cloth to clean the grill while it is hot. Some cleaners produce toxic fumes or can ignite if applied to a hot surface.
- Turn off grill controls and make certain the grill is cool before using any type of aerosol cleaner on or around the grill. The chemical that produces the spraying action could, in the presence of heat, ignite or cause metal parts to corrode.
- Keep the area surrounding the grill free from combustible materials including, fluids, trash, and vapours such as gasoline or charcoal lighter fluid. Do not obstruct the flow of combustion and ventilation air.
- To reduce the risk of fire, remove pots and pans while the operating appliance is unattended.
- Do not use accessories that are not specified for this appliance.
- The use of alcohol, prescription, or non-prescription drugs may impair the consumer's ability to properly assemble or safely operate the appliance.
- Disposal of Ashes: Ashes should be placed in a metal container with a tight-fitting lid. The closed container of ashes should be placed on a non-combustible floor or on the ground, well away from all combustible materials, pending final disposal. The ashes should remain in the closed container until all cinders have thoroughly cooled.

CAUTION: ELECTRICAL COMPONENTS





- Disconnect the electric power before servicing. Do not attempt to clean or repair the grill while it is connected to an electricity source.
- The external electrical power source used for this appliance must be electrically grounded in accordance with local codes.
- Check the plug receptacle before use. Do not plug in the grill if it is damaged.
- Make sure that the power cord does not come in contact with any hot surfaces.
- Do not cut or remove the grounding prong from the plug. Only use a GFCI-protected circuit to power the grill.
- High voltage used to power the grill can cause electric shock, or even death. Do not immerse any electronic or heating element in liquid. Do not use near any source of water or in the rain.
- When unplugging the grill, never pull from the cord. Always pull from the plug itself.



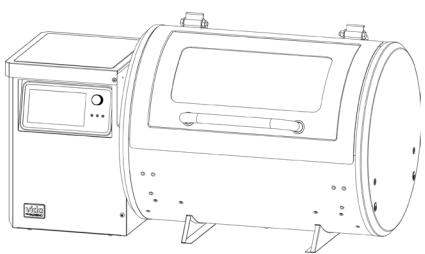
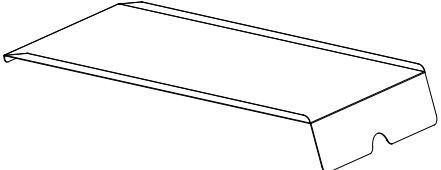
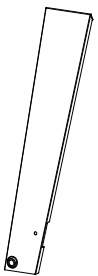

CAUTION:

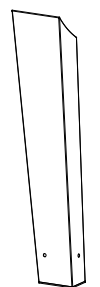
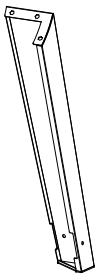
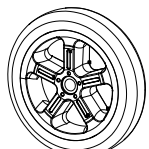
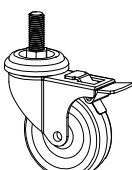
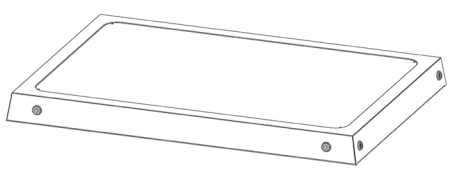
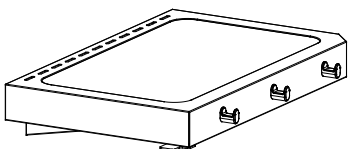
Do not install or use grill within 24" (61 cm) of combustible materials from back and sides of grill. Grill shall not be located under overhead surfaces (closed carport, garage, porch, patio) that can catch fire.

Package Parts List

1 	2 
3 	4 
5 	6 
7 <small>x2</small> 	8 <small>x2</small> 
9 	10 
11 	12 <small>x2</small> 

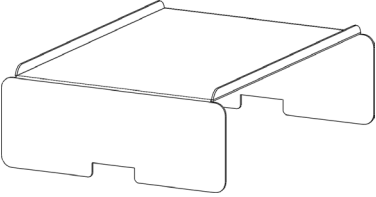
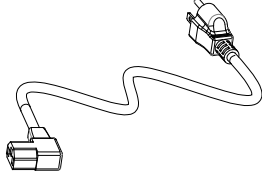
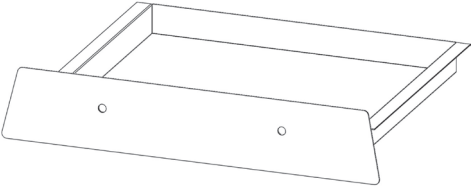
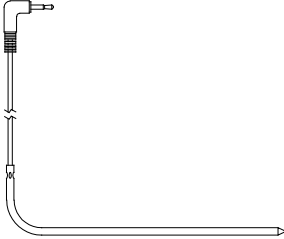
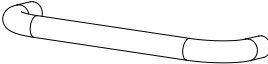
Package Parts List

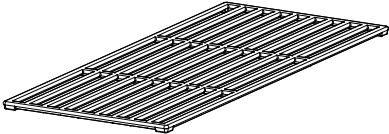
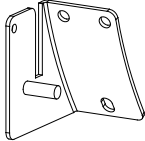
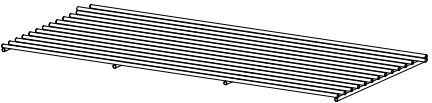
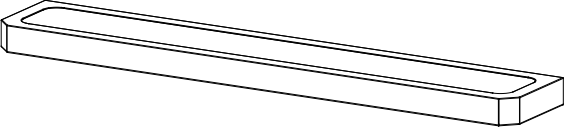
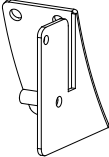
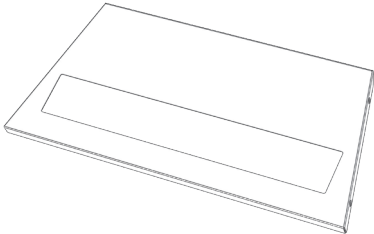
13 	14 
15 	16 
17 	18 x2 
19 x3 	20 
21 	22 
23 	24 

Hardware List

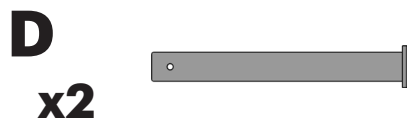
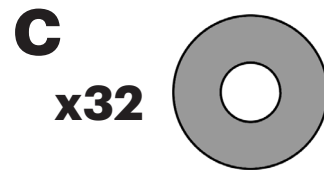
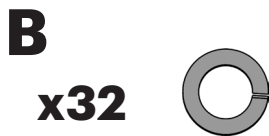

SOME PARTS COME WITH SCREWS PRE-INSTALLED. LOOSEN AND RE-TIGHTEN FOR FINAL ASSEMBLY.

TOOLS NEEDED (NOT INCLUDED):

#2 Cross-head Screwdriver 

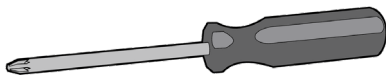

NOTE:
Some assembly steps require two people.
Use a flat and level surface to assemble the grill.

PREPARATION:

Before beginning assembly, installation or operation of this product, make sure all parts are present and undamaged. Compare parts with packaging contents list and diagram above. If any part is missing or damaged, do not attempt to assemble, install or operate the product. Contact our customer service for replacement parts.

Use a blanket, or flatten shipping carton, to cover the working area to protect the finish during assembly.

READ ALL SAFETY WARNINGS, ASSEMBLY AND INSTALLATION INSTRUCTIONS CAREFULLY BEFORE ATTEMPTING TO ASSEMBLE.

 **CAUTION!**

Incomplete or improper assembly may be dangerous. Do not use the grill if any parts are missing. The grill must be assembled properly according to the instructions provided by the manufacturer.

Assembly

1

A  x6

B  x6

C  x6

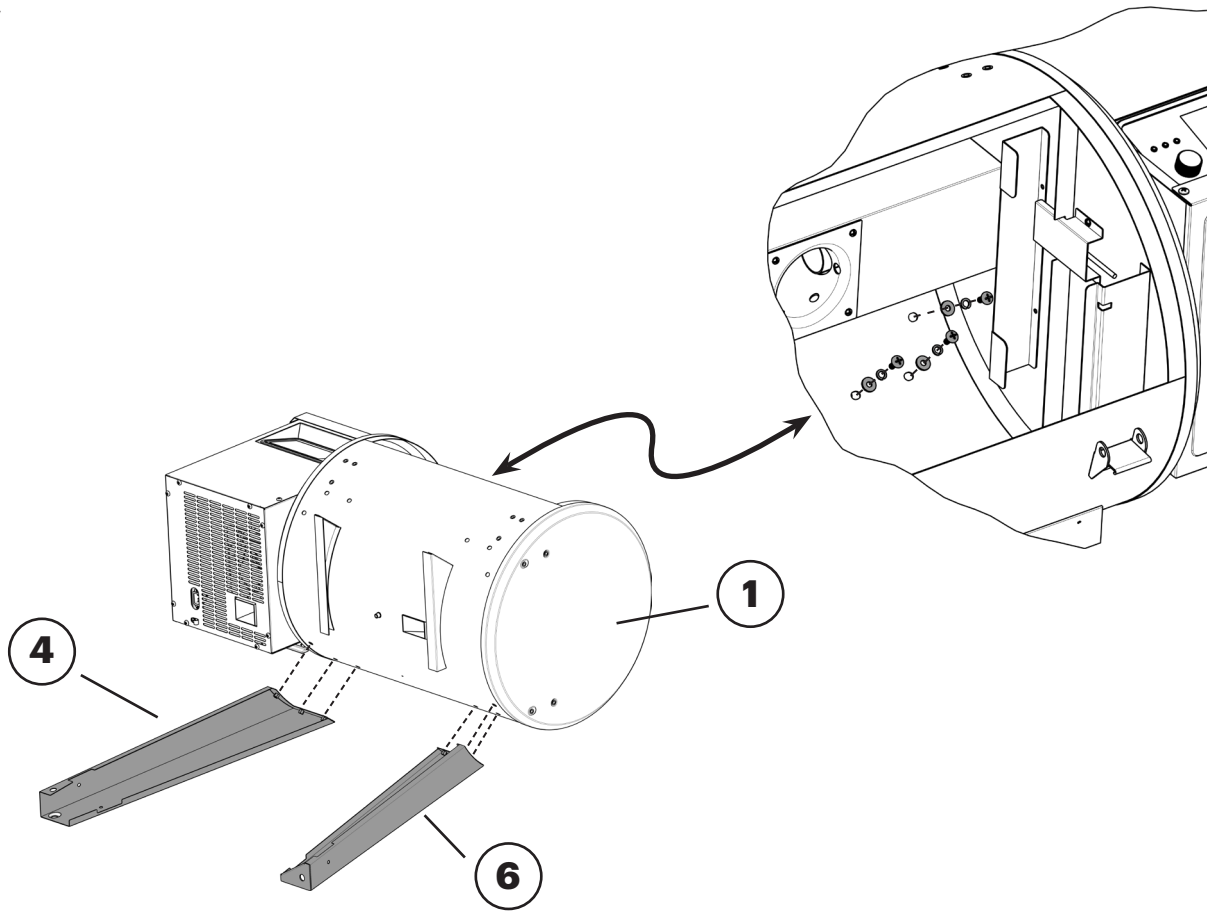

2

A  x2

B  x2

C  x2

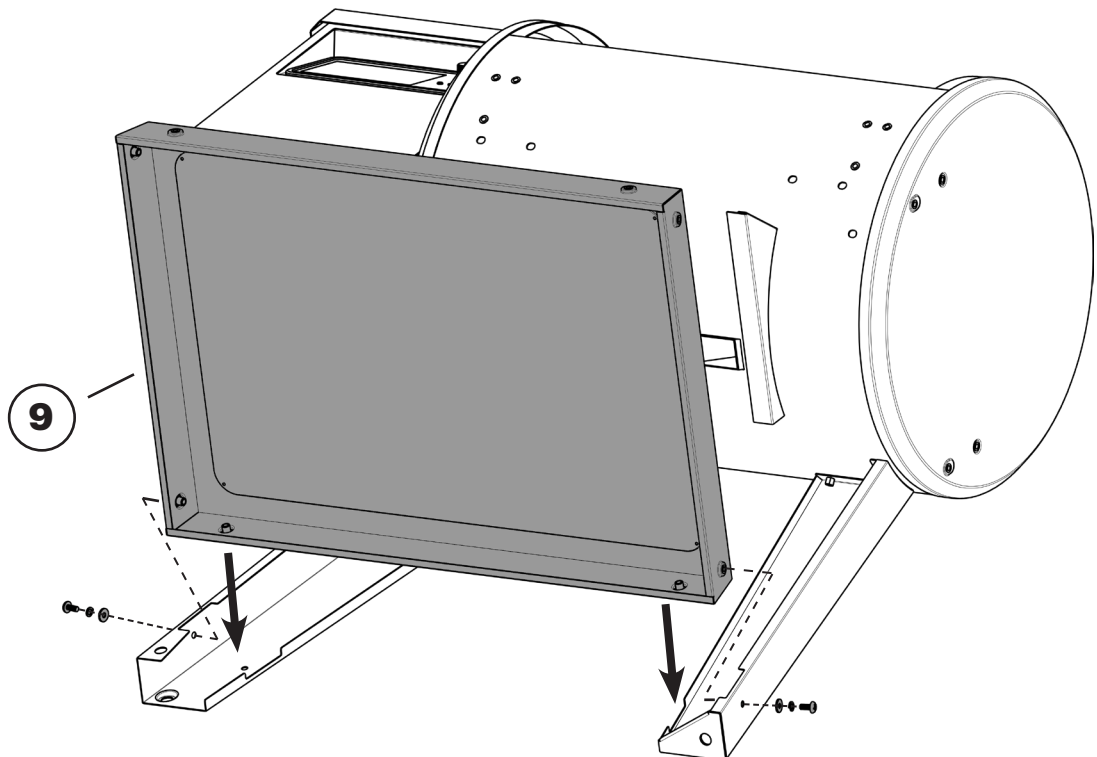

Assembly

3

H  **x4**

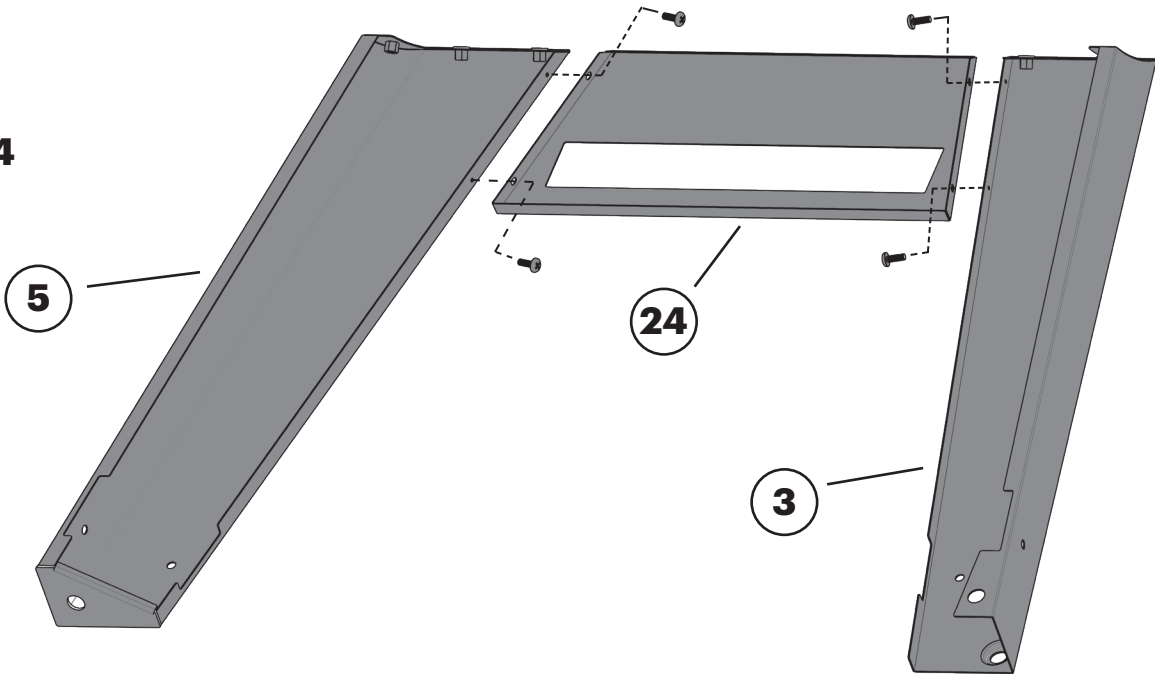

4

A  **x10**

B  **x10**

C  **x10**

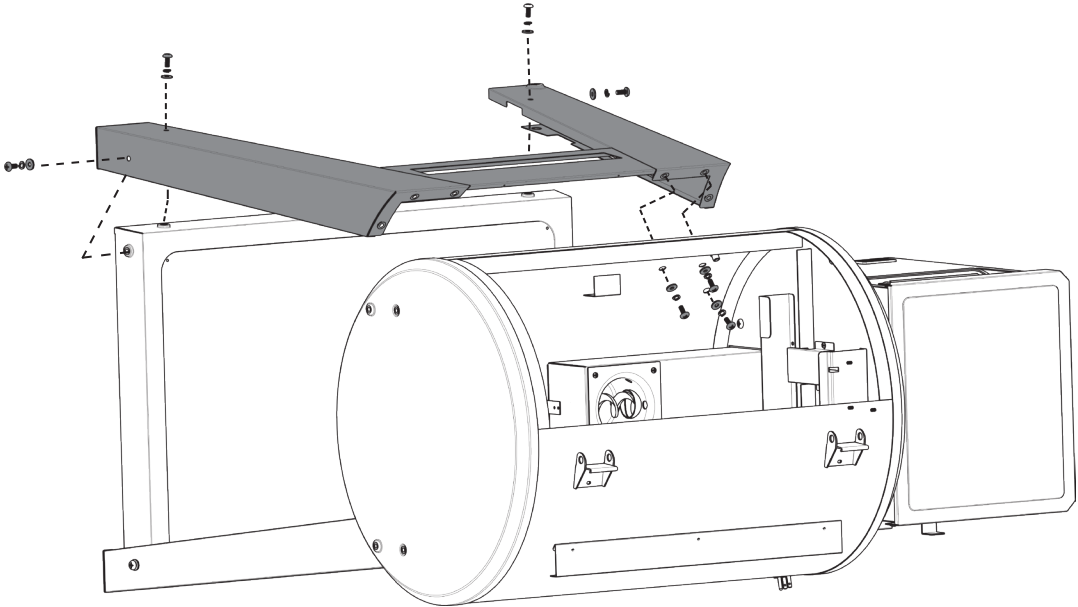

Assembly

5

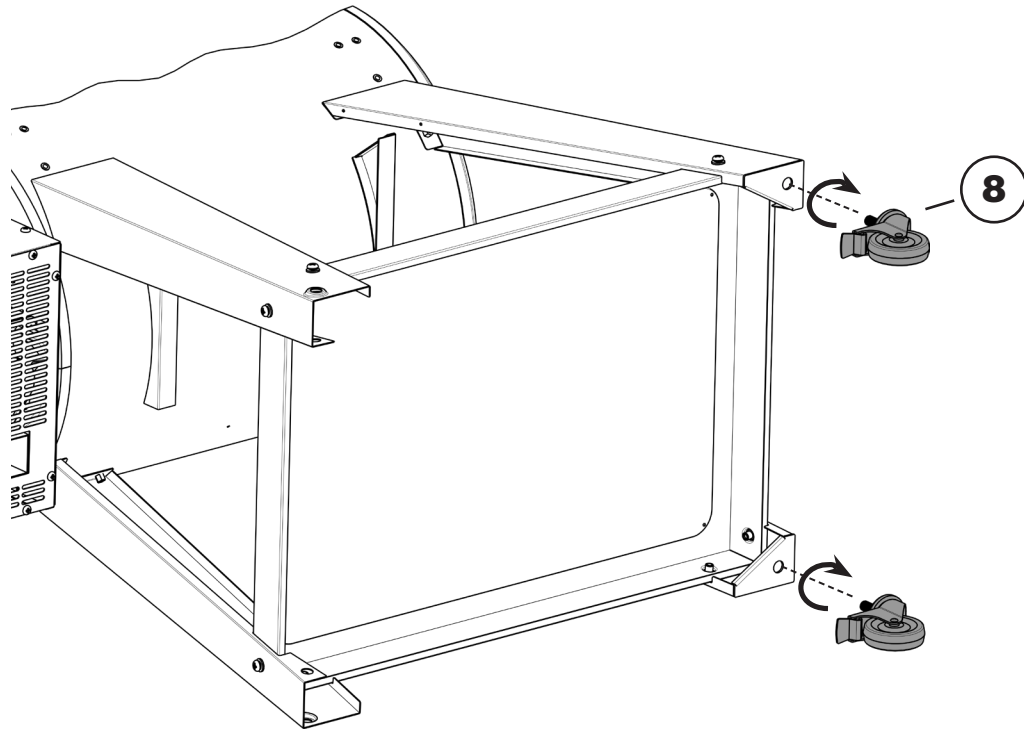

6

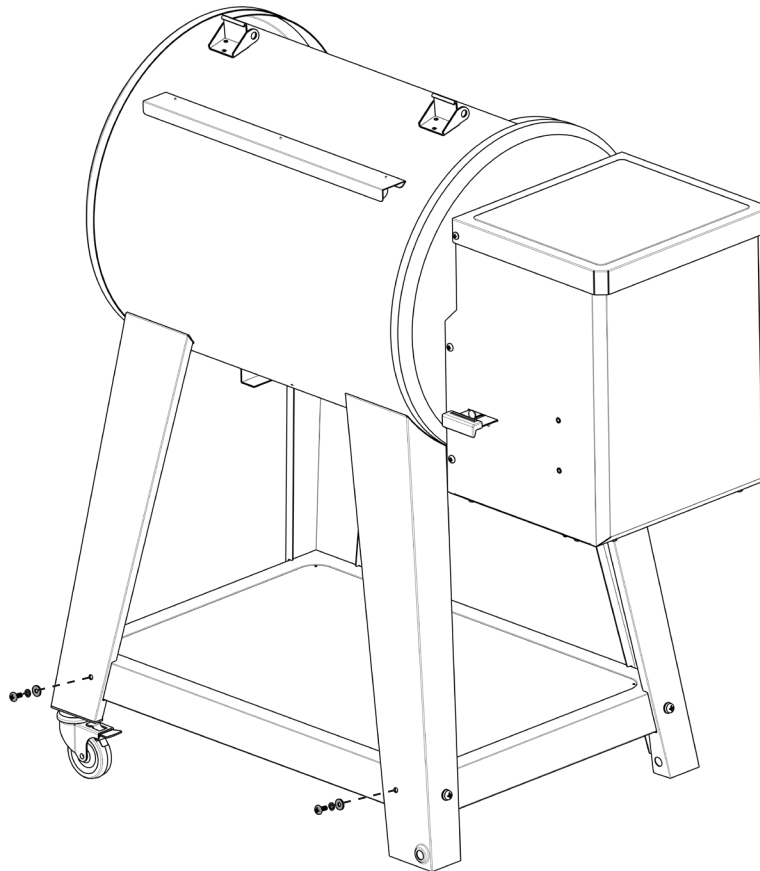
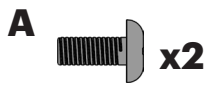

Assembly

7

D x2

E x2

F x2

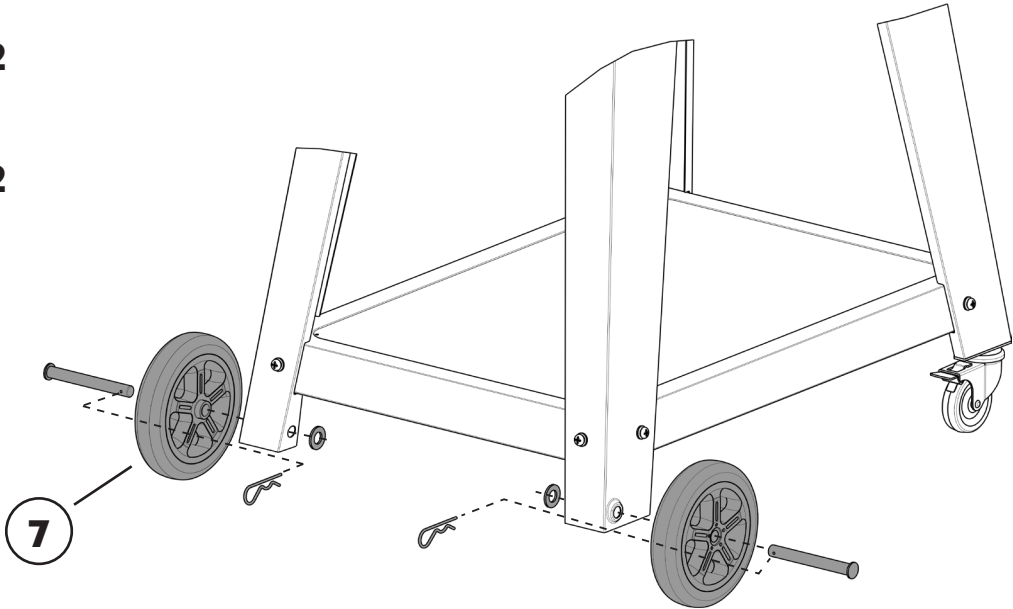

8

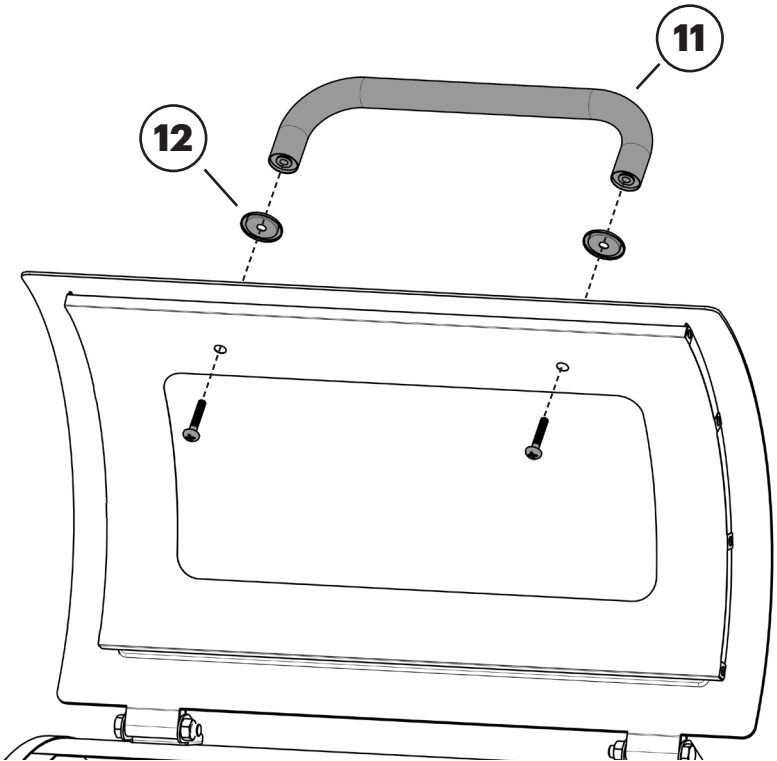

Assembly

9

A  x2

B  x2

C  x2

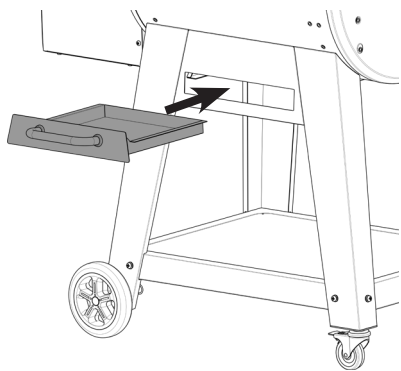
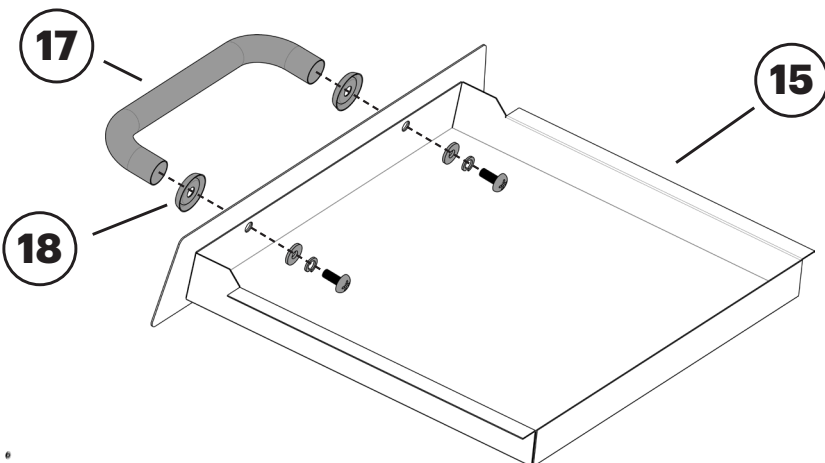

10

A  x6

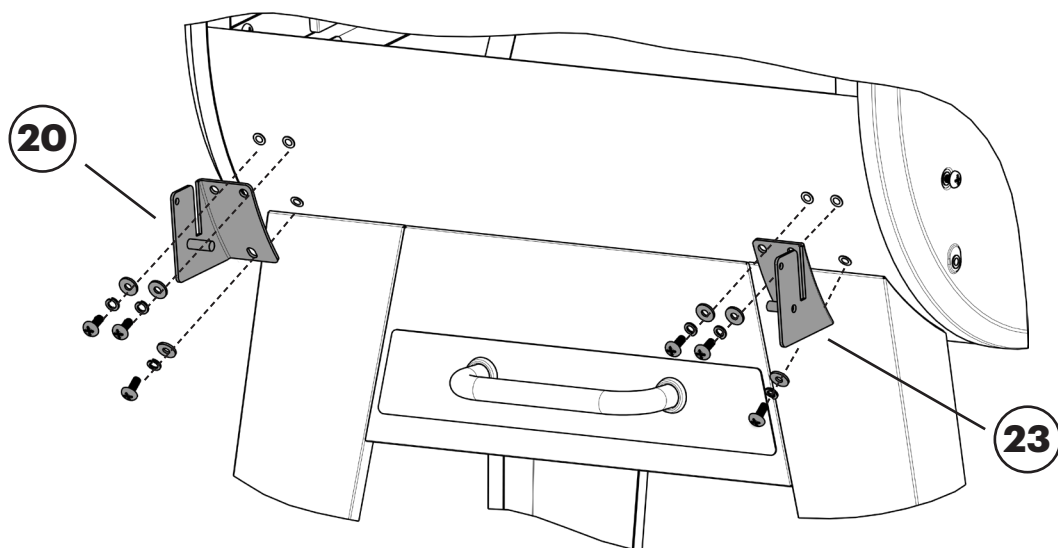

B  x6

C  x6



Assembly

11

- A  x2
- B  x2
- C  x2

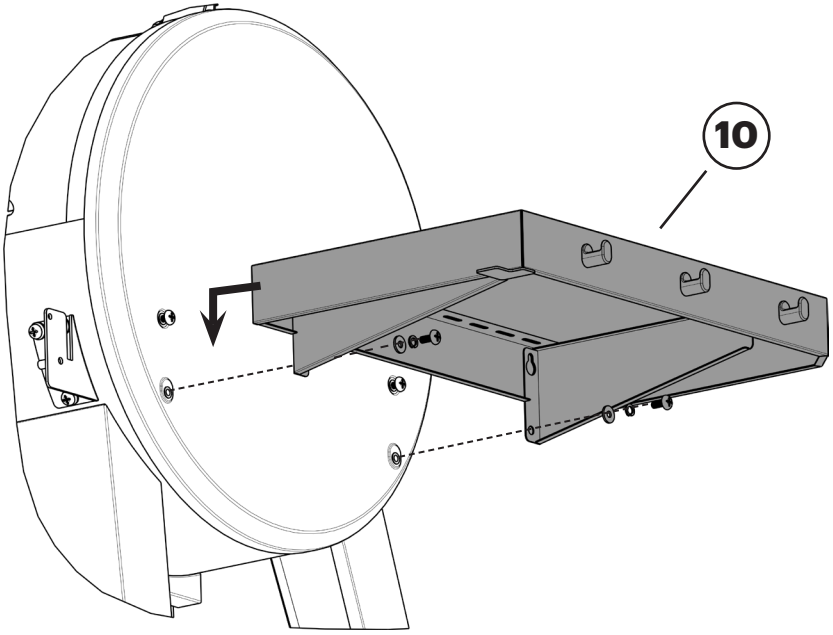

12

- G  x2

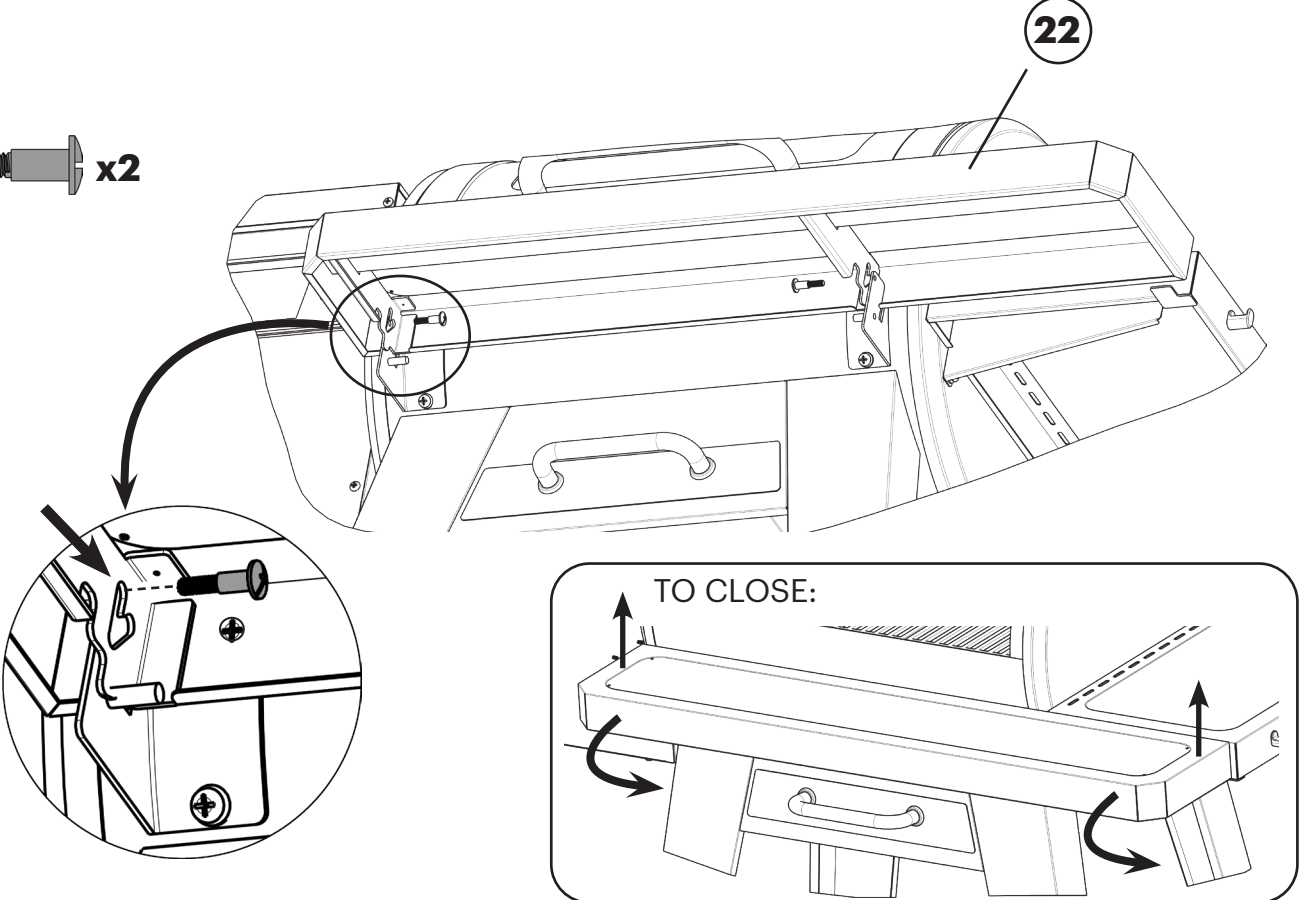

Assembly

13

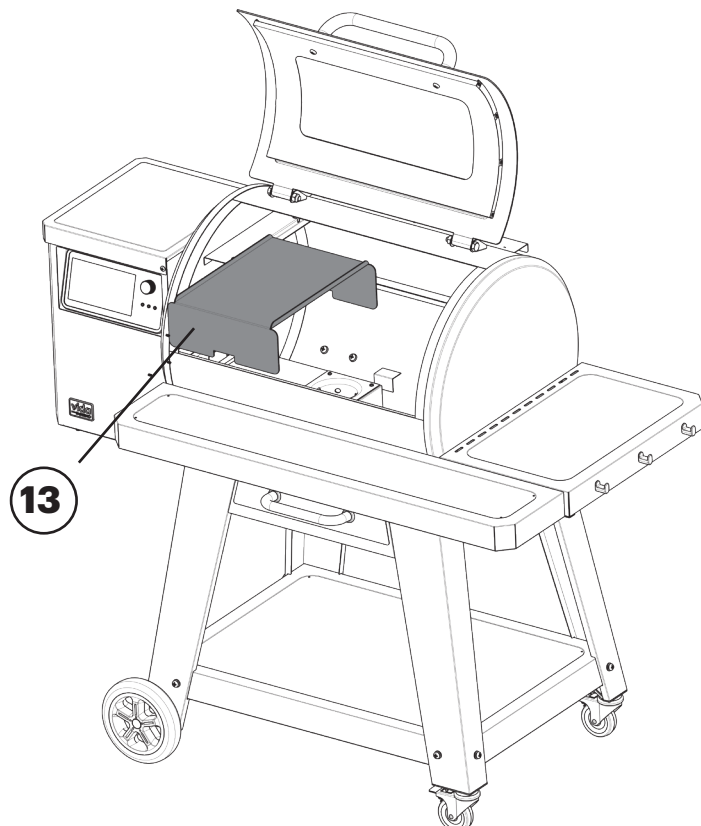

14

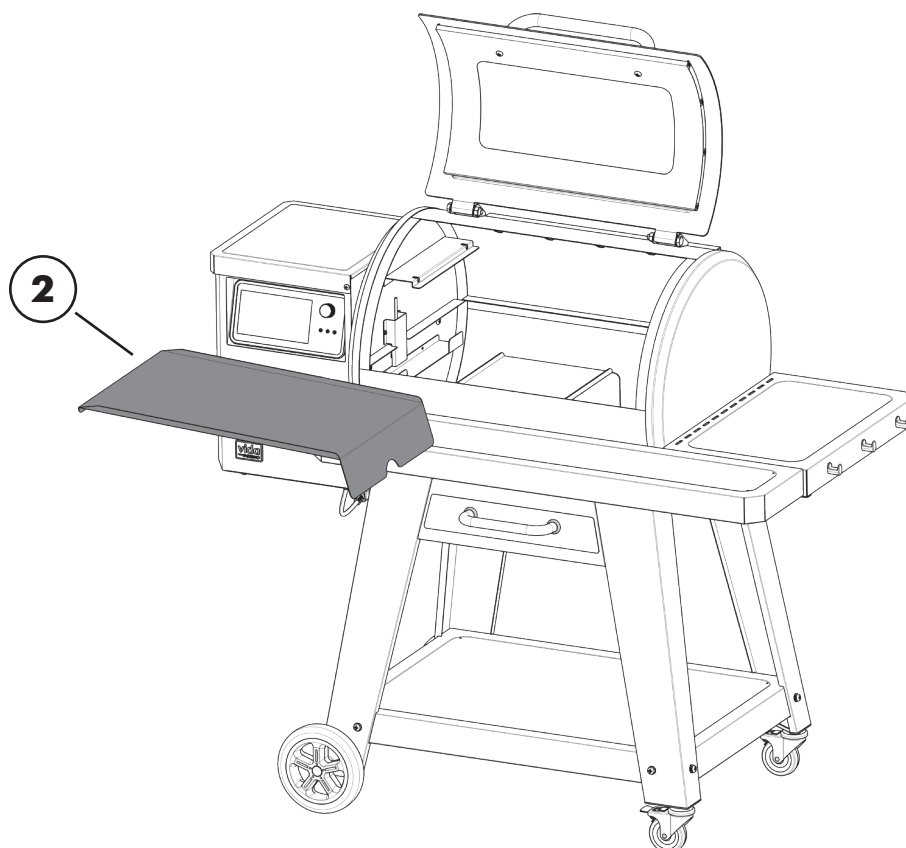

Assembly

15

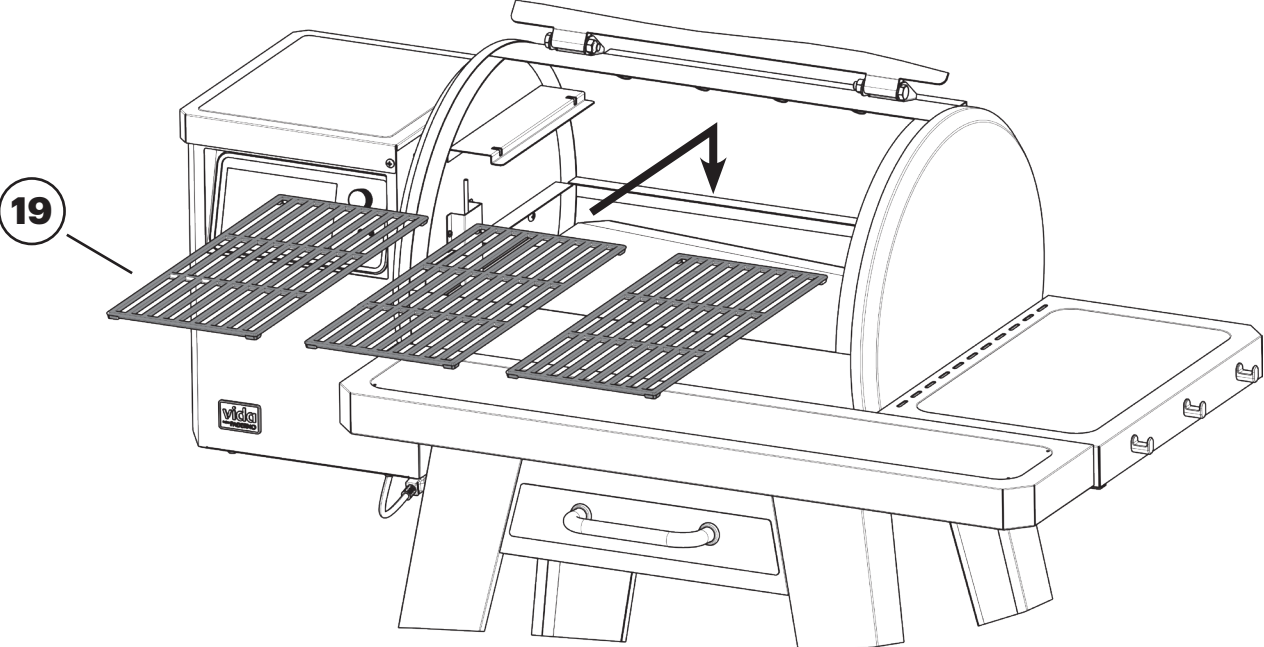

16

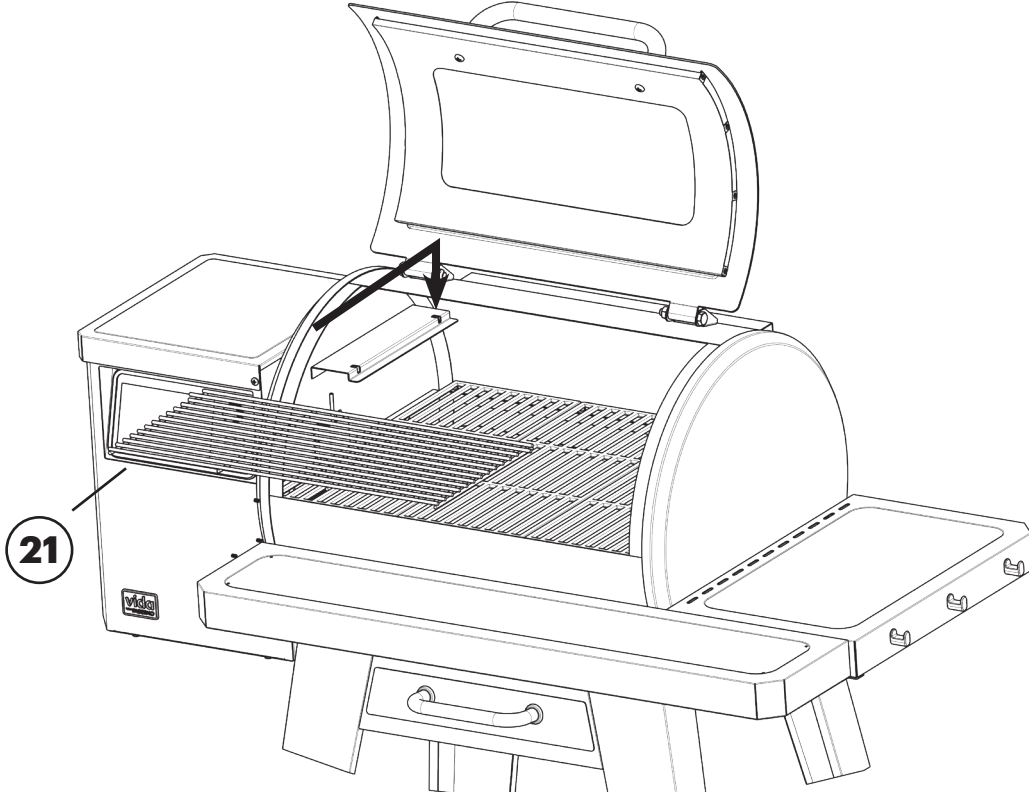

Assembly

17

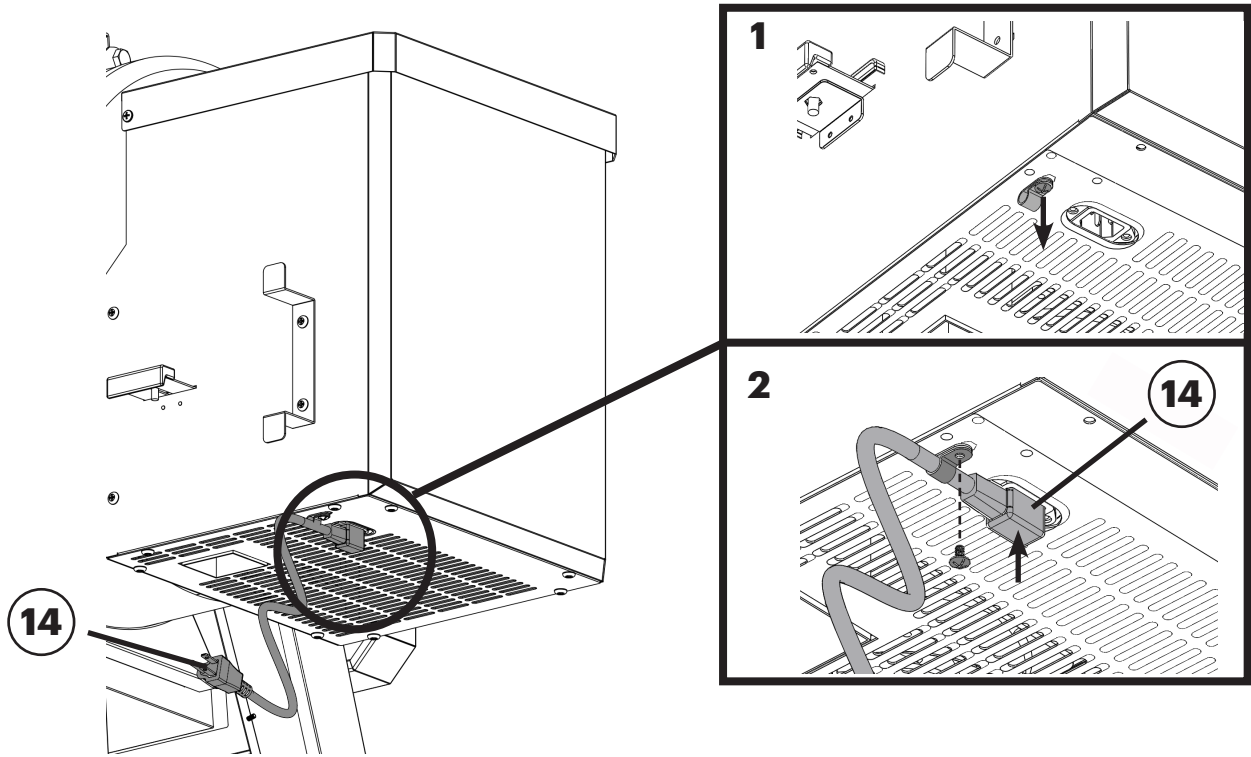

18

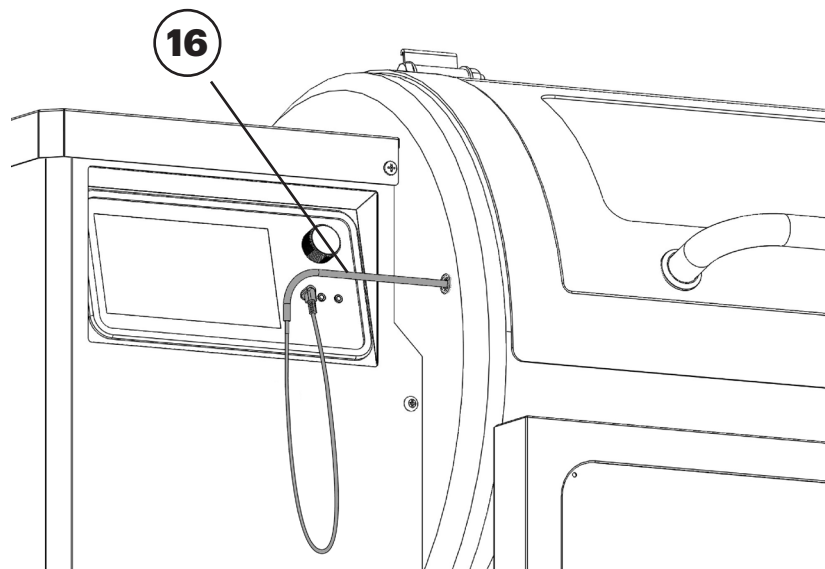

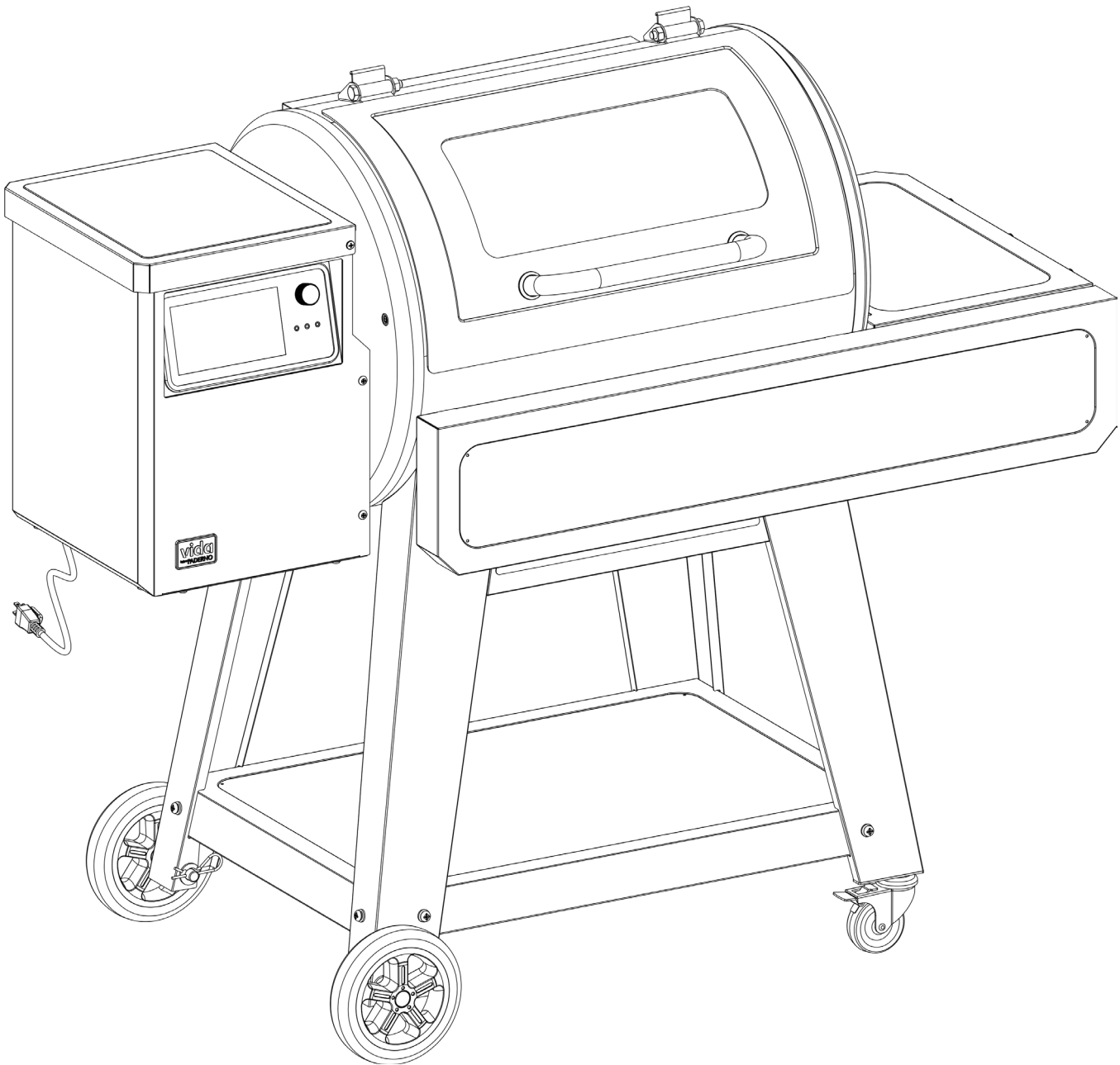

Controller Guide

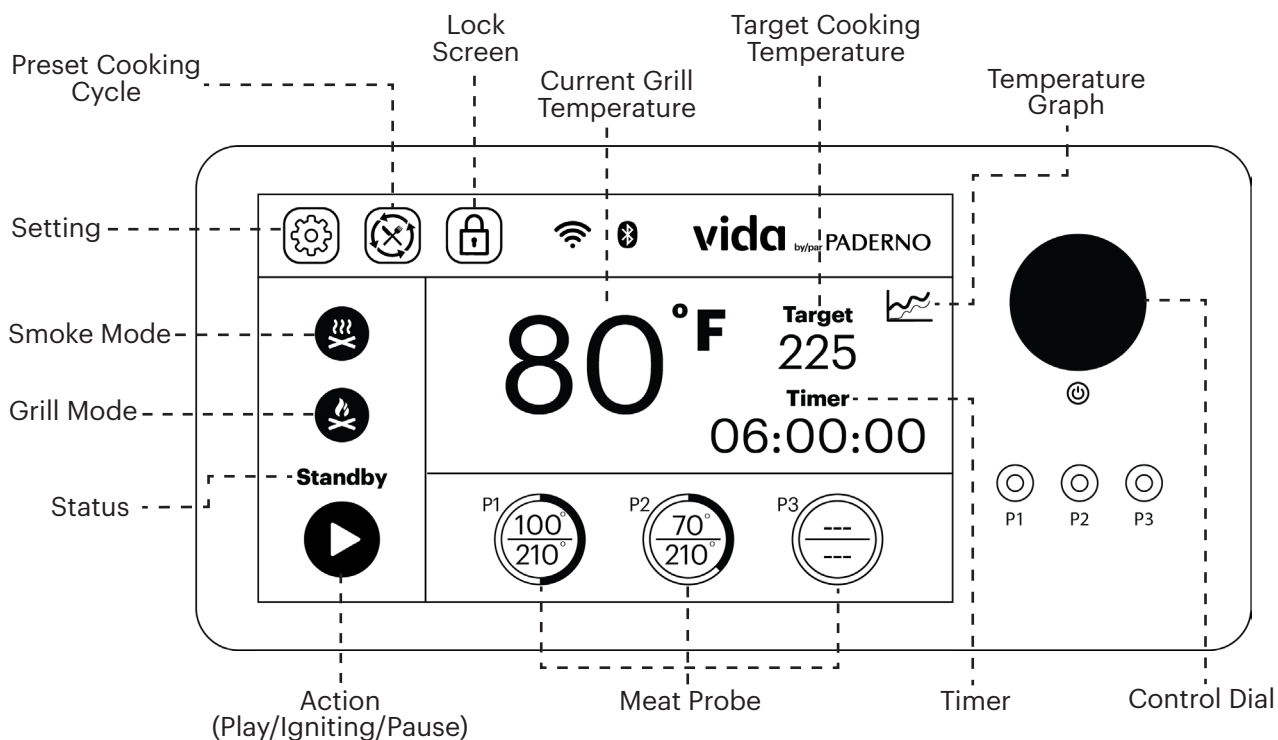

Power

Press and hold the control dial for 3 seconds to turn on the controller. A short video will appear before displaying the home screen.

NOTE: When the ambient temperature is below -15°C (5°F), the screen warms up for a maximum of 1 minute before displaying.

Setting the Target Temperature

From the home screen, touch "Target" to open the settings page. Tap "Up" or "Down" arrows to adjust the target temperature, which adjusts in increments of 25°F. Choose "Confirm" once the desired target temperature is set.

Setting the Timer

Touch "Timer" on the home screen to open the setting page. Tap "Up" or "Down" arrows to adjust the time as desired. Select "Confirm" to start the timer and return to the home screen.

When the timer expires, an audible beep will sound and the timer will flash orange until "Timer" is pressed. This will cancel the alarm and return to the home screen.

Controller Guide

Cooking Modes

The current cooking mode is identified by the orange ring around the icon.

Smoke Mode



Smoke Mode uses a program to create more smoke while providing low temperature cooking. To smoke food, press the "Smoke" icon. The default target temperature is 225°F and includes a default timer for 6 hours. This default information can be changed in "Settings".

Grill Mode



Use Grill Mode for typical barbecue grilling. When the "Grill" icon is touched, the default target temperature will change to 350°F with a default timer of 10 minutes. This default information can be changed in "Settings".

Status and Actions



Play

The "Play" icon appears when the grill is in standby mode. Touch the "Play" icon to start the ignition process once the cooking mode is selected or the desired target cooking temperature and timer are set. Or touch the "Play" icon to resume a paused cooking cycle.



Igniting

The "Igniting" icon appears during the ignition process. All the icons on the screen will be locked during this process. Once the grill has lit, the home screen will unlock. To cancel the ignition process, press and hold the control dial for 3 seconds to enter the shut down process.



Pause

The "Pause" icon appears when the controller is running a cooking cycle. Tap the "Pause" icon to pause the program, which stops the auger from feeding pellets to the fire pot. This will prevent overfeeding pellets due to a temperature decrease when the lid is open for a few minutes.

Meat Probes

The meat probe icon reflects the current temperature (top) and the target (bottom). The icon will appear blank if a meat probe is not connected or does not function. To set a target temperature, touch the desired meat probe icon. Tap the "Up" or "Down" arrows select the desired target temperature. Press "Confirm" to enter this temperature and return to the home screen.

When a meat probe reaches the programmed target temperature, an audible beep will sound and the "ring" outline of the icon will flash orange. To cancel an alarm, press the alarming meat probe or unplug that meat probe.

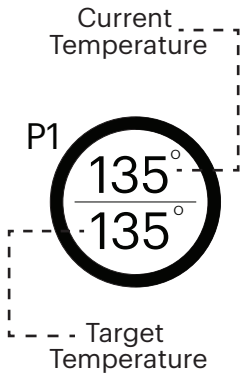

Controller Guide

Changing Default Temperature

The default temperature, for Smoke and Grill modes, as well as the temperature scale, can be modified. To do so, tap the gear icon to open the “Settings” screen and then choose “Start Up”. Select the desired cooking mode of the temperature to adjusted. Using the arrows, adjust to a new default temperature. When finished, press “Confirm” and return to the settings screen.

NOTE: The default temperature scale is Fahrenheit (F). Change to Celsius (C) by tapping the degree symbol.

Meat Probe Calibration

If you find the meat probe is not accurate, you can change the calibration from the Settings screen. Start by placing the meat probe tip into a cup of ice water for at least 5 minutes. Then insert the meat probe plug into a terminal on the controller. Open settings by tapping the gear icon. Choose “Calibration”. If the current displayed temperature does not match the ice water temperature, press “Calibrate”. Press Home to return to the home screen or select any other tab in the settings menu.

Prime/Purge Auger

If the auger tube is empty (because the grill is new or the auger has been purged for storage or changing pellet flavors), you can “Prime” the auger before use to decrease the ignition time. Do not prime the auger if it is already full. Doing so will overfill the fire pot resulting in a larger initial fire which can be hazardous.

To prime the auger, open the settings screen and tap “Auger”. Then select “Load Pellets”. The auger will automatically run for a designated time to properly load pellets into the auger tube. To cancel this action while the auger is loading, hit “Cancel”.

When you want to change the pellets or clean the grill for long term storage, you can run the auger to clear any remaining pellets from the auger tube by choosing “Empty Auger”. Once the auger stops running, you can remove the pellets from the fire pot using a vacuum.

Preset Cooking Cycles

There are four preset cooking cycles and two custom cycles that simplify cooking by automatically setting the target temperature for specific meats. Each cycle also includes an optional timer and meat probe. Select the desired cycle before or after lighting the grill.

To begin, tap the “Preset Cooking Cycle” icon at the top of the screen. Now select the preprogrammed cycle or create your custom cooking cycle. Choose other options as desired, refer to the screen image on the following page.

Once the ignition and preheat cycles have ended, a notification will appear asking you to confirm the cooking cycle. By pressing “Confirm”, the timer will begin. Otherwise, press “Cancel” to prevent the cooking cycle from beginning. The home screen will appear and the default grill temperature will remain as set by the preset cooking cycle.

Controller Guide

Preset Cooking Cycle

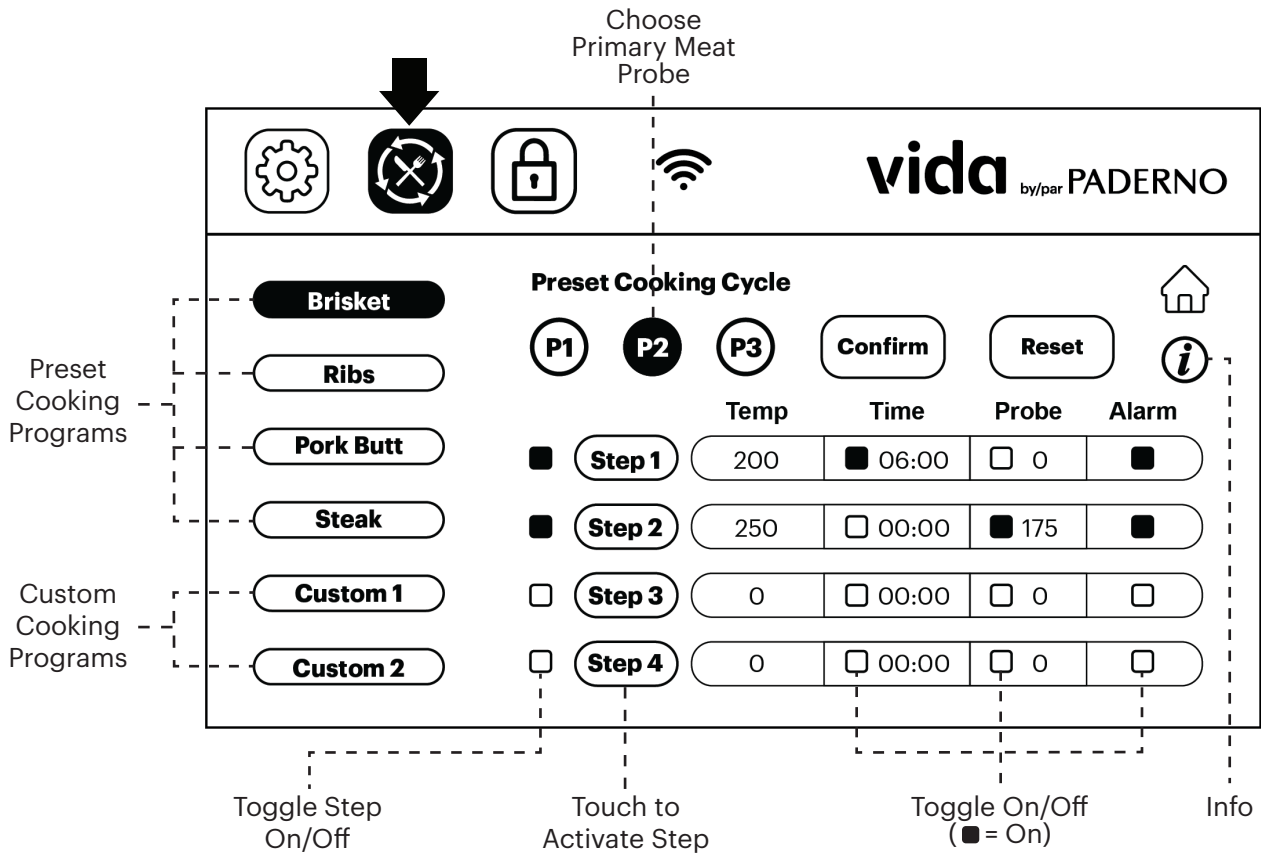

Screen Lock/Unlock

For child safety and to prevent accidental changes, the screen can automatically lock. Access the default settings to review or change the screen lock time.

NOTE: Water drops can impact the touch sensitivity. If using in rain, always lock the screen.



To Lock or Unlock, press the Lock icon at the top of the screen to open a confirmation screen.

Move the slider to confirm Lock or Unlock, depending on the current status.

Shut Down Cycle

When you have finished cooking, press and hold the dial for three seconds to initiate a pre-programmed shut down cycle. A pop-up screen will ask you to confirm this action. Then the "Shut Down" screen will appear with a count-down timer showing the process time remaining and a brief description. Do not unplug the grill until this process has ended.

Controller Guide

Error Codes

If an error is detected, the controller will display an error code. Refer to the following table for descriptions and solutions:

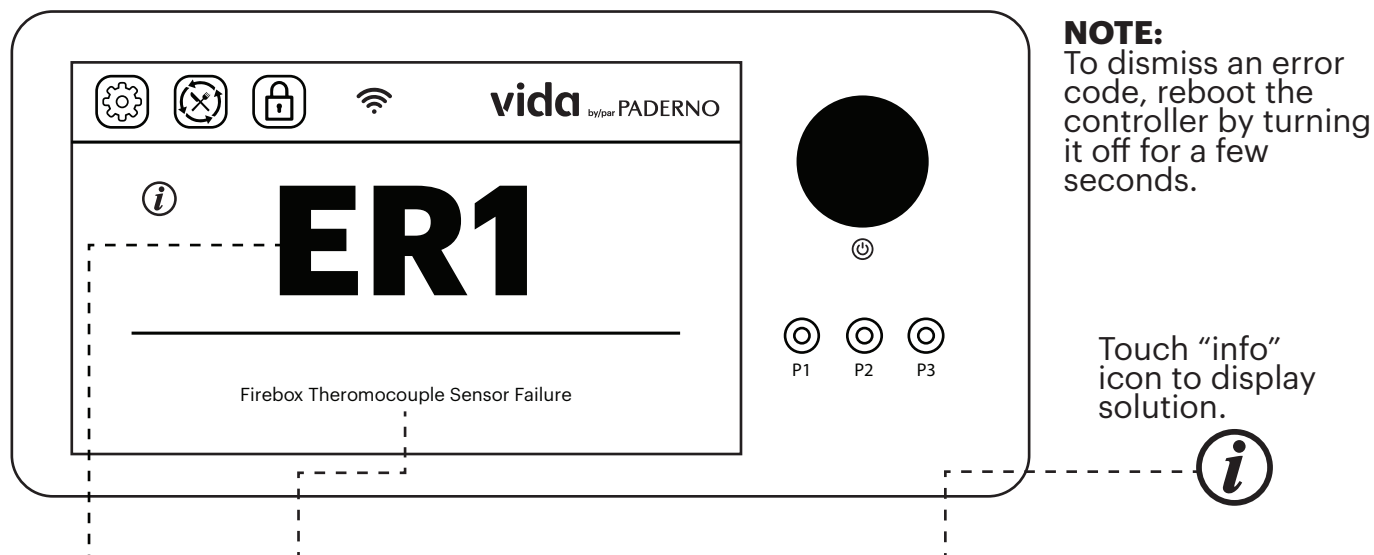

ERROR CODE	ERROR DESCRIPTION	SOLUTION
ER1	Grill Probe (RTD) Sensor Failure	Check wiring connection from RTD to the controller. If wire terminals are secure, RTD replacement may be required.
ER2	Ignition Failure	<ul style="list-style-type: none"> Inspect pellet feed system; verify pellets reach fire pot; restart. Remove excess ash and/or pellet build-up in fire pot; restart. Check ambient outdoor temperature. If RTD is too cold, the pellets may ignite but not get the RTD warm enough within the programmed time.
ER3	High Temperature Limit Protection	<ul style="list-style-type: none"> Allow grill to cool. Inspect cause of excessive temperature (grease fire, food fire, excess pellets). Clean grease or food residue. Clean fire pot. Restart grill.
ER4	Low Temperature Limit	<ul style="list-style-type: none"> Close lid (if grilling for a long time with lid open). Restart grill. Check pellet feed system and ensure pellets reach fire pot. Clean fire pot if needed. Restart grill.
ER5	Probe Communication Failure	Check meat probe connection at each port where attached. Remove mini plug and re-insert. If error continues, replace meat probe.
ER9	Network Communication Failure	Check Wi-Fi network is operating properly and the grill is in range of a strong network signal. Allow time for proper connection to be established. If it does not re-connect, reboot the grill. Sometimes rebooting the network server/router is required to issue new IP addresses (due to quantity of connected devices).

App Guide

Connecting to the Grill

Using your smartphone, download the Vida™ by PADERNO app.

NOTE: Be certain your smartphone is using the latest version of its operating system before attempting to connect to your grill.

When you open the app, you may choose to login using one your existing platforms. Otherwise, please create a new user account. You should allow push notifications for full functionality of alarms, timers and other useful notifications.

The initial connection between your device and the grill uses BLUETOOTH® wireless technology. Please be certain Bluetooth® is enabled on your device, but do not attempt to add the grill from the device settings. Also, turn off/disable Wi-Fi or disconnect from your home Wi-Fi network during this initial set-up. Turn on the grill, if not already.

In the Vida™ by PADERNO app, tap the “+” to add a new grill. Your device will scan for the grill and prompt for confirmation. Once connected, you may enter a nickname for the grill. We recommend taking a screenshot of this page as it includes the grill’s product ID number, which may be needed for tech support. The Bluetooth® icon will be displayed at the top of the controller screen while connected.

Now you are ready to connect to your home network. We recommend always using a Wi-Fi connection since it provides better communication between your device and the grill. During this step, you may be prompted to enable Wi-Fi. Select your network and enter the password. Now the Wi-Fi icon will be displayed at the top of the of the controller screen. Once connection is established, you can disable Bluetooth® if you prefer. The controller will always look for the Wi-Fi connection every time it is turned on.

You are now ready to use the Vida™ by PADERNO app to control your grill! Keep in mind that you cannot ignite, or start, your grill from the app. The app allows remote viewing and setting of cooking temperature, meat probe temperature, and alarms. During operation, various notifications will be sent to your phone or tablet to keep you informed.

Note: The Wi-Fi connection is not direct between the device and the grill. Sometimes, due to network activity, there may be a delay or variance between what the controller and device displays.

Updating the Controller

Use the Vida™ by PADERNO app to download and install the latest software to the controller.

Operating Instructions

Initial Setup

1. Remove all packaging materials from the grill.
2. Open the grill to make sure the warming rack, cooking grids, diffuser and grease tray are properly installed.
3. Open the hopper lid and verify there are no foreign objects obstructing the auger.
4. Make sure the hopper safety guard is in place and the pellet clean-out door is closed and locked.
5. Fill the hopper with your choice of barbecue pellets and close the hopper lid.
6. Make sure the power cord is connected to the grill before plugging the other end into a grounded electrical outlet.
7. Turn on your grill by pressing the dial for 3 seconds.
8. Open the grill lid.
9. Prime the auger tube by entering settings, then press "Auger". Select "Load Pellets". Once you press "Confirm", the auger will engage filling the auger with pellets and automatically stop.
10. Set the temperature to 400°F (204°C) and "Confirm".
11. Press PLAY/PAUSE to start the ignition process.
12. Once the grill has lit, close the grill lid. During ignition, there may be a large amount of smoke coming from the grill.
13. While monitoring the grill, let it run for at least 30 minutes. This will remove manufacturing process oils.
14. When complete, press the dial for 3 seconds to turn off the controller and start the automatic shutdown process.
15. Once the grill has been properly shut down and cooled, unplug the grill from the power source.
16. Open the lid and clean the cooking grids and warming rack with a grill brush or wood scraper.
17. Clean thoroughly following the instructions in "Care and Maintenance Instruction" section.
18. Once your grill is cleaned, make sure all parts are reinstalled properly before use.

Regular Use

Follow these steps every time you operate the pellet grill:

1. Make sure the hopper is filled with enough pellets.
2. Clean and dispose of any residual ash and grease. Inspect for creosote buildup. Remove accumulated grease and creosote to reduce the risk of fire. Remove ash from the fire pot at least every third use (if not each time). Accumulated ash may impact ignition and performance.
3. Always plug the power cord into a grounded outlet.
4. Open the grill lid while lighting to help verify proper ignition.

Lighting Instructions

Automatic Ignition

Make sure your grill is properly set up and ready for use.

1. Open the grill lid and verify all the components are in place.
2. Ensure the hopper does not contain foreign objects and is filled with enough barbecue pellets.
3. Be certain the auger is primed and ready for use.
4. Plug the power cord into a properly grounded electrical outlet and press the power button (press dial 3 seconds).
5. Press PLAY or first enter the desired cooking mode and temperature. If nothing was entered, the grill will start with a default target temperature of 350°F (176°C). Within 5 minutes smoke should be visible. If not, turn off the controller and wait 5 minutes before repeating.
6. Once the grill has lit, close the lid. Set the desired cooking mode and temperature, if not already entered.

NOTE: The screen locks until the ignition is completed. The only way to stop the ignition process is to press and hold the dial for 3 seconds to proceed with the shutdown process.

Manual Ignition

Make sure your grill is properly set up and ready for use.

1. Open the grill lid and remove the grids, grease tray and diffuser.
2. Ensure the hopper does not contain foreign objects and is filled with enough barbecue pellets.
3. Check that the fire pot is clean and does not contain any foreign objects.
4. Plug the power cord into a properly grounded electrical outlet.
5. The auger should be primed and ready for use. If not, review Prime/Purge Auger section for proper setup.
6. Add a handful of barbecue pellets to the fire pot.
7. Add a natural wood fire starter or gel to the fire pot.
8. With a long match or lighter, ignite the fire starter.
9. After the pellets are burning well, replace the diffuser, grease tray and grids.
10. Turn on the controller (press dial for 3 seconds).
11. Press PLAY/PAUSE. Observe that more pellets have been added and are burning properly.
12. Once the grill has lit, close the lid.
13. Set the desired cooking mode and temperature if not already entered.

Automatic Shutdown

When finished grilling, the grill must be properly turned off to clear the fire pot of any remaining pellets and ashes. Use this procedure to properly turn off your grill after each use:

1. Open the lid, remove all meat probes and food.
2. With the lid still open, press the power button to begin the automatic shutdown process. During this process, a countdown timer will be displayed and the fan will continue to run until the grill temperature falls below 54°C (130°F) or the time has expired. Do not unplug the grill until after the display and fan have completed this process and turned off.
3. Unplug the grill from the power source.
4. Wait until the grill has cooled down before storing it.

Operating Instructions

Changing/Removing Pellets

When you want to change the pellet flavor, clear the hopper for maintenance or long-term storage, follow these steps to empty the hopper and auger:

1. Locate the opening on the bottom of pellet hopper and place a large container underneath.
2. From the back of the grill, loosen the lock screw on the pellet clean-out door by turning counter-clockwise at least two full turns. See Figure A.
3. Pull out the pellet clean-out door to release the pellets into your container.
4. Once the hopper is empty, return the pellet clean-out door to the closed position and lock it by rotating the lock screw clockwise. See Figure B.
5. Connect the grill to a grounded outlet and turn on the power.
6. Press prime so the auger removes pellets from the auger screw into the fire pot. Repeat this until the auger is empty.
7. Using a vacuum, remove the pellets and ash from the fire pot.

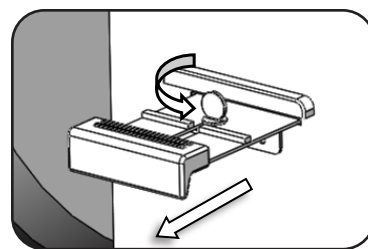

Figure A. Clean-Out Door Open.

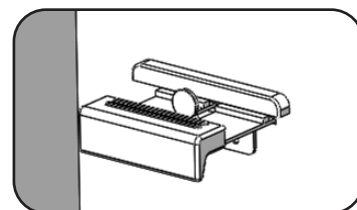

Figure B. Clean-Out Door Closed.

WARNING: Visually inspect the hopper finger safety guard to make sure that it is in place and not damaged before filling the hopper with barbecue pellets. DO NOT change pellets when the grill is hot.

Meat Temperature Probes

To monitor the meat's internal temperature while cooking, install a meat probe as follows:

1. Insert a meat probe mini connector into one of the ports found on the controller, under the dial knob.
2. Route the probe through the grommet of the cooking chamber end cap, located just to the right of the controller. Doing so avoids the wire(s) passing through the lid opening, which might damage the wire when the lid closes.
3. Open the lid to access the meat probe. While wearing heat protective gloves, insert the probe tip into the desired meat at its thickest portion. Position the probe tip near the centre of the meat thickness.
4. Place the meat in a desired location and close the lid.
5. Monitor the meat's internal temperature on the controller's screen or on the app.

Care and Maintenance



CAUTION!

MAKE SURE THE GRILL IS COOL AND DISCONNECTED FROM THE POWER SOURCE BEFORE PERFORMING ANY CLEANING OR MAINTENANCE.

GRILL INTERIOR

COOKING GRIDS

- After the grill has cooled, scrub both sides of the cooking grates with a grill brush.
- Any stubborn, baked-on food residue can be scraped off with a scraper.
- Grids can also be removed from the grill and washed with dish soap and warm water. Dry thoroughly.
- The cooking grids should be cleaned after each use.

GREASE SYSTEM

- Remove the cooking grids and scrape food and grease residue off the grease tray using a scraper or grill brush.
- Grease tray can also be removed from the grill and washed with dish soap and warm water. Dry thoroughly.
- The grease tray should be cleaned after each use. The grease pan should be emptied once it reaches $\frac{3}{4}$ full.

INTERIOR SURFACES

- Brush or scrape off any grease or debris accumulated on the interior surfaces using a scraper or grill brush.
- Vacuum ash and food remnants out of the bottom of the firebox and fire pot.
- All surfaces can be washed with mild, soapy water and/or a mild degreaser. Dry thoroughly.
- Interior surfaces should be monitored and cleaned when build-up of grease and debris has accumulated, but not less than twice per year.

GRILL EXTERIOR

COATED AND PLASTIC SURFACES

- After the grill has cooled completely, exterior surfaces can be wiped down with a mild mixture of soap and water. Dry thoroughly.
- Do not use abrasive cleaners.

STAINLESS STEEL

- Use a stainless-steel cleaner and non-abrasive, lint-free cloth to clean stainless steel components.
- Always rub in the direction of the grain to avoid scratches and do not use paper towels.

TO PREVENT DAMAGE TO ELECTRICAL COMPONENTS, DO NOT SPRAY THE GRILL WITH A GARDEN HOSE OR POWER WASHER.

STORAGE

- Always store your grill with a cover between uses to prevent corrosion or other damage to the grill, especially if it is stored in a rainy or humid environment.
- Do not store the grill with the hopper and/or auger full of pellets, especially in wet or humid conditions. Moisture will expand the pellets and can lead to an auger jam. Use the pellet quick-release door located at the back of the hopper to empty leftover pellets into a container and burn off any pellets remaining in the auger before storage.
- Store spare wood pellets in an airtight container, away from heat-producing appliances, moisture, and other fuel containers. Before use, check the freshness of your pellets by breaking one in half. The pellet should break with a snap. If it crumbles, that means your pellet is not fresh and will impact the performance of the grill.



Creosote – Formation and Need for Removal

When wood pellets are burned slowly, they produce tar and other organic vapours that combine with expelled moisture to form creosote. The creosote vapours condense in a relatively cool oven flue and exhaust hood of a slow burning fire. As a result, creosote residue accumulates on the flue lining and exhaust hood. When ignited, this creosote makes an extremely hot fire.

The grease duct should be inspected at least twice a year to determine when grease and/or creosote build up has occurred.

When grease or creosote has accumulated, it should be removed to reduce risk of fire.

Troubleshooting

ERROR CODES

On a rare occasion, your controller may detect an issue and you may see an error code displayed on the screen. The following table offers descriptions and recommended solutions:

ERROR CODE	ERROR DESCRIPTION	SOLUTION
ER1	Grill Probe (RTD) Sensor Failure	Check wiring connection from RTD to the controller. If wire terminals are secure, RTD replacement may be required.
ER2	Ignition Failure	<ul style="list-style-type: none"> Inspect pellet feed system; verify pellets reach fire pot; restart. Remove excess ash and/or pellet build-up in fire pot; restart. Check ambient outdoor temperature. If RTD is too cold, the pellets may ignite but not get the RTD warm enough within the programmed time.
ER3	High Temperature Limit Protection	<ul style="list-style-type: none"> Allow grill to cool. Inspect cause of excessive temperature (grease fire, food fire, excess pellets). Clean grease or food residue. Clean fire pot. Restart grill.
ER4	Low Temperature Limit	<ul style="list-style-type: none"> Close lid (if grilling for long time with lid open). Restart grill. Check pellet feed system and ensure pellets reach fire pot. Clean fire pot if needed. Restart grill.
ER5	Probe Communication Failure	Check meat probe connection at each port where attached. Remove mini plug and re-insert. If error continues, replace meat probe.
ER9	Network Communication Failure	Check Wi-Fi network is operating properly and the grill is in range of a strong network signal. Allow time for proper connection to be established. If it does not re-connect, reboot the grill. Sometimes rebooting the network server/router is required to issue new IP addresses (due to quantity of connected devices).

NOTE: To dismiss an error code, reboot the controller by turning it off for a few seconds.

IMPORTANT: Use only factory authorized parts, if replacement is necessary. The use of any unauthorized part can be dangerous and will void your warranty.

Contact us for replacement parts or warranty issues at 1-800-263-9768.

FREQUENTLY ASKED QUESTIONS

QUESTION	ANSWER
How do I clear an auger jam?	<ol style="list-style-type: none"> Unplug the grill and wait for it to cool. Look inside the hopper to determine if the jam can be cleared from there or near the fire pot. If the jam cannot be cleared, empty all pellets from the hopper and then remove the hopper assembly from the grill. Disassemble the hopper housing to expose the internal components. Remove the auger motor and auger screw. Contact customer service if more instructions are required.
Why is the temperature fluctuating?	Temperature fluctuations are normal. Any significant fluctuation could be the result of wind and ambient temperature, pellet quantity, or lack of maintenance. Avoid using the pellet grill when it is windy or raining outside.
Why is the fire not remaining lit?	Excess ash in the fire pot can cause ignition failure and prevent the fire from burning. Unplug the grill and wait for it to cool, then remove the cooking grids, grease tray, and heat diffuser. Remove any pellets and ash from the fire pot. A vacuum with a hose attachment is ideal to remove ashes from the fire pot.
Why is the grill not heating to the set temperature?	This is typically due to lack of air in the fire pot or poor pellet quality. Verify the fan is operating properly. Inspect the fire pot and remove excess ash. Check the hopper and add more pellets if necessary. Replace them if they are damp.
How do I avoid flare-ups?	If you are cooking food that contains a lot of fat or grease, keep the temperature at or below 350°F (177°C). Avoid placing food directly over the fire pot area.

Limited Warranty

The manufacturer warrants to the original consumer-purchaser only that this product (Model Number 910-05005/SKU 085-0219-0) shall be free from defects in workmanship and materials after correct assembly and under normal and reasonable home use for the periods indicated below beginning on the date of purchase. The manufacturer reserves the right to require photographic evidence of damage, or the return of defective parts, postage and or freight pre-paid by the consumer, for review and examination.

FIREBOX: 5-year LIMITED warranty

ELECTRICAL COMPONENTS: 3-year LIMITED warranty

COOKING GRID(S): 3-Year LIMITED warranty; does not cover dropping, chipping, scratching, or surface damage.

ALL OTHER PARTS: 1-Year LIMITED warranty (includes, but is not limited to, frame, housing, cart, igniter); does not cover chipping, scratching, cracking surface corrosion, scratches or rust.

Upon consumer supplying proof of purchase as provided herein, Manufacturer will repair or replace the parts that are proven defective during the applicable warranty period. Parts required to complete such repair or replacement shall be free of charge to you except for shipping costs, as long as the purchaser is within the warranty period from the original date of purchase. The original consumer/purchaser will be responsible for all shipping charges of parts replaced under the terms of this limited warranty. This limited warranty is applicable in the United States and Canada, is only available to the original owner of the product and is not transferable. Manufacturer requires reasonable proof of your date of purchase. Therefore, you should retain your sales receipt and/or invoice. If the unit was received as a gift, please ask the gift-giver to send in the receipt on your behalf, to the below address. Defective or missing parts subject to this limited warranty will not be replaced without proof of purchase. This limited warranty applies to the functionality of the product ONLY and does not cover cosmetic issues such as scratches, dents, corruptions or discoloring by heat, abrasive and chemical cleaners or any tools used in the assembly or installation of the appliance, surface rust, or the discoloration of stainless-steel surfaces. Surface rust, corrosion, or powder paint chipping on metal parts that does not affect the structural integrity of the product is not considered a defect in workmanship or material and is not covered by this warranty. This limited warranty will not reimburse you for the cost of any inconvenience, food, personal injury or property damage. If an original replacement part is not available, a comparable replacement part will be sent. You will be responsible for all shipping charges of parts replaced under the terms of this limited warranty.

ITEMS MANUFACTURER WILL NOT PAY FOR:

- Service calls to your home.
- Repairs when your product is used for other than normal, single-family household or residential use.
- Damage resulting from accident, alteration, misuse, lack of maintenance/cleaning, abuse, fire, flood, acts of God, improper installation, and installation not in accordance with electrical or plumbing codes or use of products not approved by the manufacturer.
- Any food loss due to product failures.
- Replacement parts or repair labour costs for units operated outside the United States or Canada.
- Pickup and delivery of your product.
- Postage fees or photo processing fees for photos sent in as documentation.
- Repairs to parts or systems resulting from unauthorized modifications made to the product.
- The removal and/or re-installation of your product.
- Shipping cost, standard or expedited, for warranty/non-warranty and replacement parts.

DISCLAIMER OF IMPLIED WARRANTIES; LIMITATION OF REMEDIES

Repair or replacement of defective parts is your exclusive remedy under the terms of this limited warranty. Manufacturer will not be responsible for any consequential or incidental damages arising from the breach of either this limited warranty or any applicable implied warranty, or for failure or damage resulting from acts of God, improper care and maintenance, grease fire, accident, alteration, replacement of parts by anyone other than Manufacturer, misuse, transportation, commercial use, abuse, hostile environments (inclement weather, acts of nature, animal tampering), improper installation or installation not in accordance with local codes or printed manufacturer instructions.

THIS LIMITED WARRANTY IS THE SOLE EXPRESS WARRANTY GIVEN BY THE MANUFACTURER. NO PRODUCT PERFORMANCE SPECIFICATION OR DESCRIPTION WHEREVER APPEARING IS WARRANTED BY MANUFACTURER EXCEPT TO THE EXTENT SET FORTH IN THIS LIMITED WARRANTY. ANY IMPLIED WARRANTY PROTECTION ARISING UNDER THE LAWS OF ANY STATE OR PROVINCE, INCLUDING IMPLIED WARRANTY OF MERCHANTABILITY OR FITNESS FOR A PARTICULAR PURPOSE OR USE, IS HEREBY LIMITED IN DURATION TO THE DURATION OF THIS LIMITED WARRANTY.

Neither Dealers nor the retail establishment selling this product have any authority to make any additional warranties or to promise remedies in addition to or inconsistent with those stated above. Manufacturer's maximum liability, in any event, shall not exceed the documented purchase price of the product paid by the original consumer. This warranty only applies to units purchased from an authorized retailer and or re-seller. NOTE: Some states and provinces do not allow an exclusion or limitation of incidental or consequential damages, so some of the above limitations or exclusions may not apply to you; this limited warranty gives you specific legal rights as set for herein. You may also have other rights, which vary from province to province.

All consumer returns, parts orders, general questions, and troubleshooting assistance can be acquired by calling our Customer Service Department at 1-800-263-9768

Service

BEFORE YOU CALL FOR SERVICE have the following information available:

- 1. Serial number:** The serial number can be found on the rating label located inside the hopper lid.
- 2. Model number:** The model number is located on the cover page of the assembly manual.
- 3. Proof of purchase** by the original owner.

If your product is damaged do not return to the store for replacement of damaged or defective parts. Vida™ by PADERNO Customer Support will ensure that all in-stock replacement parts arrive at your home.

Concealed Damage: If damage is unnoticed until merchandise is unpacked, resolve issue by contacting Vida™ by PADERNO Customer Support immediately. Missing or damaged parts should be claimed within 30 days of purchase.

Grill Information

Complete and retain for future use. We recommend to save a copy of the receipt in this manual.

MODEL NUMBER: 910-05005

SERIAL NUMBER: _____

PURCHASE DATE: _____

Call our Vida™ by PADERNO Customer Support

1-800-263-9768

Ordering Replacement Parts

Refer to the replacement parts list on the following pages to ensure you order the correct part needed for your repair. Keep this assembly and operating instruction manual for convenient referral, and for replacement parts ordering.

Contact our customer service at 1-800-263-9768 to order replacement parts.

Electrical Circuit Diagram

120 V AC, 60 Hz, 230 W

