

---

# FCC Test Report

---

Report No.: AGC00408230403FE06

**FCC ID** : 2A3DR-PADP1  
**APPLICATION PURPOSE** : Original Equipment  
**PRODUCT DESIGNATION** : Smart tablet  
**BRAND NAME** : AGM  
**MODEL NAME** : AGM\_PAD\_P1  
**APPLICANT** : AGM MOBILE LIMITED  
**DATE OF ISSUE** : Jun. 01, 2023  
**STANDARD(S)** : FCC Part 15 Subpart E §15.407  
**REPORT VERSION** : V1.0

Attestation of Global Compliance (Shenzhen) Co., Ltd



Any report having not been signed by authorized approver, or having been altered without authorization, or having not been stamped by the "Dedicated Testing/Inspection Stamp" is deemed to be invalid. Copying or excerpting portion of, or altering the content of the report is not permitted without the written authorization of AGC. The test results presented in the report apply only to the tested sample. Any objections to report issued by AGC should be submitted to AGC within 15days after the issuance of the test report. Further enquiry of validity or verification of the test report should be addressed to AGC by agc01@agccert.com.

Attestation of Global Compliance(Shenzhen)Co., Ltd  
Attestation of Global Compliance(Shenzhen)Std & Tech Co., Ltd  
Tel: +86-755 2523 4088 E-mail: agc@agccert.com Web: <http://www.agccert.com/>



### REPORT REVISE RECORD

Report Version	Revise Time	Issued Date	Valid Version	Notes
V1.0	/	Jun. 01, 2023	Valid	Initial Release

Any report having not been signed by authorized approver, or having been altered without authorization, or having not been stamped by the "Dedicated Testing/Inspection Stamp" is deemed to be invalid. Copying or excerpting portion of, or altering the content of the report is not permitted without the written authorization of AGC. The test results presented in the report apply only to the tested sample. Any objections to report issued by AGC should be submitted to AGC within 15days after the issuance of the test report. Further enquiry of validity or verification of the test report should be addressed to AGC by [agc01@agccert.com](mailto:agc01@agccert.com).

**TABLE OF CONTENTS**

**1. VERIFICATION OF CONFORMITY..... 5**

**2. GENERAL INFORMATION ..... 6**

    2.1. PRODUCT DESCRIPTION..... 6

    2.2. TABLE OF CARRIER FREQUENCIES..... 7

    2.3. RELATED SUBMITTAL(S) / GRANT (S) ..... 10

    2.4. TEST METHODOLOGY..... 10

    2.5. SPECIAL ACCESSORIES ..... 10

    2.6. EQUIPMENT MODIFICATIONS ..... 10

    2.7. ANTENNA REQUIREMENT ..... 10

**3. TEST ENVIRONMENT ..... 11**

    3.1 ADDRESS OF THE TEST LABORATORY ..... 11

    3.2 TEST FACILITY..... 11

    3.3 ENVIRONMENTAL CONDITIONS..... 12

    3.4 MEASUREMENT UNCERTAINTY..... 12

    3.5 LIST OF EQUIPMENTS USED..... 13

**4. DESCRIPTION OF TEST MODES ..... 14**

**5. SYSTEM TEST CONFIGURATION ..... 15**

    5.1. CONFIGURATION OF EUT SYSTEM..... 15

    5.2. EQUIPMENT USED IN EUT SYSTEM..... 15

    5.3. SUMMARY OF TEST RESULTS ..... 15

**6. RF OUTPUT POWER MEASUREMENT..... 16**

    6.1 MEASUREMENT LIMITS ..... 16

    6.2 MEASUREMENT PROCEDURE ..... 16

    6.3 MEASUREMENT SETUP (BLOCK DIAGRAM OF CONFIGURATION)..... 17

    6.4 MEASUREMENT RESULT ..... 17

**7. 6DB&26DB BANDWIDTH MEASUREMENT ..... 20**

    7.1 MEASUREMENT LIMITS ..... 20

    7.2 MEASUREMENT PROCEDURE ..... 20

    7.3 MEASUREMENT SETUP (BLOCK DIAGRAM OF CONFIGURATION)..... 20

    7.4 MEASUREMENT RESULTS..... 21

**8. POWER SPECTRAL DENSITY MEASUREMENT ..... 62**

    8.1 MEASUREMENT LIMITS ..... 62

    8.2 MEASUREMENT PROCEDURE ..... 62

    8.3 MEASUREMENT SETUP (BLOCK DIAGRAM OF CONFIGURATION)..... 62

    8.4 MEASUREMENT RESULT ..... 63

**9. CONDUCTED SPURIOUS EMISSION..... 96**

Any report having not been signed by authorized approver, or having been altered without authorization, or having not been stamped by the “Dedicated Testing/Inspection Stamp” is deemed to be invalid. Copying or excerpting portion of, or altering the content of the report is not permitted without the written authorization of AGC. The test results presented in the report apply only to the tested sample. Any objections to report issued by AGC should be submitted to AGC within 15days after the issuance of the test report. Further enquiry of validity or verification of the test report should be addressed to AGC by agc01@agccert.com.

9.1 MEASUREMENT LIMIT .....	96
9.2 MEASUREMENT PROCEDURE .....	96
9.3 MEASUREMENT SETUP (BLOCK DIAGRAM OF CONFIGURATION) .....	96
9.4 MEASUREMENT RESULTS.....	97
<b>10. RADIATED EMISSION .....</b>	<b>141</b>
10.1 LIMITS OF RADIATED EMISSION TEST .....	141
10.2 MEASUREMENT PROCEDURE .....	142
10.3 MEASUREMENT SETUP (BLOCK DIAGRAM OF CONFIGURATION).....	144
10.4 MEASUREMENT RESULT .....	145
<b>11. AC POWER LINE CONDUCTED EMISSION TEST .....</b>	<b>180</b>
11.1. LIMITS OF LINE CONDUCTED EMISSION TEST .....	180
11.2. BLOCK DIAGRAM OF LINE CONDUCTED EMISSION TEST .....	180
11.3. PRELIMINARY PROCEDURE OF LINE CONDUCTED EMISSION TEST .....	181
11.4. FINAL PROCEDURE OF LINE CONDUCTED EMISSION TEST .....	181
11.5. TEST RESULT OF LINE CONDUCTED EMISSION TEST .....	182
<b>APPENDIX I: PHOTOGRAPHS OF TEST SETUP .....</b>	<b>184</b>
<b>APPENDIX II: PHOTOGRAPHS OF EUT .....</b>	<b>184</b>



Any report having not been signed by authorized approver, or having been altered without authorization, or having not been stamped by the “Dedicated Testing/Inspection Stamp” is deemed to be invalid. Copying or excerpting portion of, or altering the content of the report is not permitted without the written authorization of AGC. The test results presented in the report apply only to the tested sample. Any objections to report issued by AGC should be submitted to AGC within 15days after the issuance of the test report. Further enquiry of validity or verification of the test report should be addressed to AGC by agc01@agccert.com.

### 1. VERIFICATION OF CONFORMITY

<b>Applicant</b>	AGM MOBILE LIMITED
<b>Address</b>	FLAT/RM 2253 22/F HOI TAI FACTORY ESTATE TSING YEUNG CIRCUIT TUEN MUN NT HONG KONG,CHINA
<b>Manufacturer</b>	SHENZHEN AIJIEMO SCIENCE AND TECHNOLOGY CO.,LTD
<b>Address</b>	1st Floor 101 and 2nd Floor 201, Building A2, Huafeng Century Technology Park, Nanchang Community, Xixiang, Baoan District, Shenzhen, China
<b>Factory</b>	SHENZHEN AIJIEMO SCIENCE AND TECHNOLOGY CO.,LTD
<b>Address</b>	1st Floor 101 and 2nd Floor 201, Building A2, Huafeng Century Technology Park, Nanchang Community, Xixiang, Baoan District, Shenzhen, China
<b>Product Designation</b>	Smart tablet
<b>Brand Name</b>	AGM
<b>Test Model</b>	AGM_PAD_P1
<b>Date of receipt of test item</b>	Apr. 26, 2023
<b>Date of test</b>	Apr. 26, 2023~Jun. 01, 2023
<b>Deviation</b>	No any deviation from the test method
<b>Condition of Test Sample</b>	Normal
<b>Test Result</b>	Pass
<b>Report Template</b>	AGCRT-US-BGN/RF

We hereby certify that:

The above equipment was tested by Attestation of Global Compliance (Shenzhen) Co., Ltd. The test data, data evaluation, test procedures, and equipment configurations shown in this report were made in accordance with the procedures given in ANSI C63.10 (2013) and the energy emitted by the sample EUT tested as described in this report is in compliance with requirement of FCC Part 15 Rules requirement.

Prepared By	 <hr/> Bibo Zhang (Project Engineer)	Jun. 01, 2023
Reviewed By	 <hr/> Calvin Liu (Reviewer)	Jun. 01, 2023
Approved By	 <hr/> Max Zhang Authorized Officer	Jun. 01, 2023

Any report having not been signed by authorized approver, or having been altered without authorization, or having not been stamped by the “Dedicated Testing/Inspection Stamp” is deemed to be invalid. Copying or excerpting portion of, or altering the content of the report is not permitted without the written authorization of AGC. The test results presented in the report apply only to the tested sample. Any objections to report issued by AGC should be submitted to AGC within 15days after the issuance of the test report. Further enquiry of validity or verification of the test report should be addressed to AGC by agc01@agccert.com.

## 2. GENERAL INFORMATION

### 2.1. PRODUCT DESCRIPTION

<b>Equipment Type</b>	<input type="checkbox"/> Outdoor access points <input type="checkbox"/> Indoor access points <input type="checkbox"/> Fixed P2P access points <input checked="" type="checkbox"/> Client devices
<b>Operation Frequency</b>	<input checked="" type="checkbox"/> U-NII 1:5150MHz~5250MHz <input checked="" type="checkbox"/> U-NII 2A: 5250MHz~5350MHz <input checked="" type="checkbox"/> U-NII 2C:5470MHz~5725MHz <input checked="" type="checkbox"/> U-NII 3: 5725MHz~5850MHz
<b>DFS Design Type</b>	<input type="checkbox"/> Master <input type="checkbox"/> Slave with radar detection <input checked="" type="checkbox"/> Slave without radar detection
<b>TPC Function</b>	<input type="checkbox"/> Yes <input checked="" type="checkbox"/> No
<b>Hardware Version</b>	V1.00
<b>Software Version</b>	N2060.6.01.00.00
<b>Test Frequency Range</b>	For 802.11a/n-HT20/ac-VHT20: 5180~5240MHz, 5260~5320MHz, 5500~5720MHz, 5745~5825MHz For 802.11n-HT40/ac-VHT40: 5190~5230MHz, 5270~5310MHz, 5510~5710MHz, 5755~5795MHz For 802.11ac-VHT80: 5210MHz, 5290MHz, 5530~5690MHz, 5775MHz
<b>Output Power</b>	IEEE 802.11a(HT20):10.36dBm; IEEE 802.11n(HT20):10.18dBm; IEEE802.11n(HT40):10.37dBm; IEEE 802.11ac(VHT20):10.11dBm; IEEE802.11ac(VHT40):10.44dBm; IEEE802.11ac(VHT80):10.79dBm;
<b>Modulation</b>	802.11a/n:(64-QAM, 16-QAM, QPSK, BPSK) OFDM 802.11ac :(256-QAM, 64-QAM, 16-QAM, QPSK, BPSK) OFDM
<b>Data Rate</b>	802.11a:6/9/12/18/24/36/48/54Mbps; 802.11n:up to 300Mbps; 802.11ac:up to 866.6Mbps;
<b>Number of channels</b>	7 channels of U-NII-1 Band 7 channels of U- NII-2A Band 12 channels of U-NII-2C Band 8 channels of U- NII 3 Band
<b>Antenna Designation</b>	PIFA Antenna
<b>Antenna Gain</b>	1.0dBi
<b>Power Supply</b>	DC 3.8V by battery

Any report having not been signed by authorized approver, or having been altered without authorization, or having not been stamped by the "Dedicated Testing/Inspection Stamp" is deemed to be invalid. Copying or excerpting portion of, or altering the content of the report is not permitted without the written authorization of AGC. The test results presented in the report apply only to the tested sample. Any objections to report issued by AGC should be submitted to AGC within 15days after the issuance of the test report. Further enquiry of validity or verification of the test report should be addressed to AGC by agc01@agccert.com.

## 2.2. TABLE OF CARRIER FREQUENCIES

For 5180~5240MHz:

4 channels are provided for 802.11a, 802.11n (HT20), 802.11ac (VHT20):

Channel	Frequency	Channel	Frequency
36	5180 MHz	44	5220 MHz
40	5200 MHz	48	5240 MHz

2 channels are provided for 802.11n (HT40), 802.11ac (VHT40), 802.11ax (HE40):

Channel	Frequency	Channel	Frequency
38	5190 MHz	46	5230 MHz

1 channel is provided for 802.11ac (VHT80), 802.11ax (VHT80):

Channel	Frequency	Channel	Frequency
42	5210 MHz	--	--

For 5260~5320MHz:

5 channels are provided for 802.11a, 802.11n (HT20), 802.11ac (VHT20):

Channel	Frequency	Channel	Frequency
52	5260 MHz	60	5300 MHz
56	5280 MHz	64	5320 MHz

2 channels are provided for 802.11n (HT40), 802.11ac (VHT40), 802.11ax (HE40):

Channel	Frequency	Channel	Frequency
54	5270 MHz	62	5310 MHz

1 channel is provided for 802.11ac (VHT80), 802.11ax (HE80):

Channel	Frequency	Channel	Frequency
58	5290 MHz	--	--

Any report having not been signed by authorized approver, or having been altered without authorization, or having not been stamped by the "Dedicated Testing/Inspection Stamp" is deemed to be invalid. Copying or excerpting portion of, or altering the content of the report is not permitted without the written authorization of AGC. The test results presented in the report apply only to the tested sample. Any objections to report issued by AGC should be submitted to AGC within 15days after the issuance of the test report. Further enquiry of validity or verification of the test report should be addressed to AGC by agc01@agccert.com.

**For 5500~5720MHz:**

**12 channels are provided for 802.11a, 802.11n (HT20), 802.11ac (VHT20):**

Channel	Frequency	Channel	Frequency
100	5500 MHz	124	5620 MHz
104	5520 MHz	128	5640 MHz
108	5540 MHz	132	5660 MHz
112	5560 MHz	136	5680 MHz
116	5580 MHz	140	5700 MHz
120	5600 MHz	144	5720 MHz

**6 channels are provided for 802.11n (HT40), 802.11ac (VHT40):**

Channel	Frequency	Channel	Frequency
102	5510 MHz	126	5630 MHz
110	5550 MHz	134	5670 MHz
118	5590 MHz	142	5710 MHz

**3 channel is provided for 802.11ac (VHT80):**

Channel	Frequency	Channel	Frequency
106	5530 MHz	122	5610 MHz
138	5690 MHz	--	--

Any report having not been signed by authorized approver, or having been altered without authorization, or having not been stamped by the "Dedicated Testing/Inspection Stamp" is deemed to be invalid. Copying or excerpting portion of, or altering the content of the report is not permitted without the written authorization of AGC. The test results presented in the report apply only to the tested sample. Any objections to report issued by AGC should be submitted to AGC within 15days after the issuance of the test report. Further enquiry of validity or verification of the test report should be addressed to AGC by agc01@agccert.com.



**For 5745~5825MHz:**

**5 channels are provided for 802.11a, 802.11n (HT20), 802.11ac (VHT20):**

Channel	Frequency	Channel	Frequency
149	5745 MHz	161	5805 MHz
153	5765 MHz	165	5825 MHz
157	5785 MHz	--	--

**2 channels are provided for 802.11n (HT40), 802.11ac (VHT40):**

Channel	Frequency	Channel	Frequency
151	5755 MHz	159	5795 MHz

**1 channel is provided for 802.11ac (VHT80):**

Channel	Frequency	Channel	Frequency
155	5775 MHz	--	--

Any report having not been signed by authorized approver, or having been altered without authorization, or having not been stamped by the "Dedicated Testing/Inspection Stamp" is deemed to be invalid. Copying or excerpting portion of, or altering the content of the report is not permitted without the written authorization of AGC. The test results presented in the report apply only to the tested sample. Any objections to report issued by AGC should be submitted to AGC within 15days after the issuance of the test report. Further enquiry of validity or verification of the test report should be addressed to AGC by agc01@agccert.com.

### 2.3. RELATED SUBMITTAL(S) / GRANT (S)

This submittal(s) (test report) is intended for **FCC ID: 2A3DR-PADP1** filing to comply with the FCC Part 15 requirements.

### 2.4. TEST METHODOLOGY

No.	Identity	Document Title
1	FCC 47 CFR Part 2	Frequency allocations and radio treaty matters; general rules and regulations
2	FCC 47 CFR Part 15	Radio Frequency Devices
3	ANSI C63.10-2013	American National Standard for Testing Unlicensed Wireless Devices
4	KDB 662911	662911 D01 Multiple Transmitter Output v02r01
5	KDB 789033	789033 D02 General U-NII Test Procedures New Rules v02r01

### 2.5. SPECIAL ACCESSORIES

Refer to section 5.2.

### 2.6. EQUIPMENT MODIFICATIONS

Not available for this EUT intended for grant.

### 2.7. ANTENNA REQUIREMENT

Standard Requirement
<p><b>15.203 requirement:</b> An intentional radiator shall be designed to ensure that no antenna other than that furnished by the responsible party shall be used with the device. The use of a permanently attached antenna or of an antenna that uses a unique coupling to the intentional radiator, the manufacturer may design the unit so that a broken antenna can be replaced by the user, but the use of a standard antenna jack or electrical connector is prohibited.</p>
<p><b>EUT Antenna:</b> The non-detachable antenna inside the device cannot be replaced by the user at will. The gain is 0dBi</p>

Any report having not been signed by authorized approver, or having been altered without authorization, or having not been stamped by the "Dedicated Testing/Inspection Stamp" is deemed to be invalid. Copying or excerpting portion of, or altering the content of the report is not permitted without the written authorization of AGC. The test results presented in the report apply only to the tested sample. Any objections to report issued by AGC should be submitted to AGC within 15 days after the issuance of the test report. Further enquiry of validity or verification of the test report should be addressed to AGC by agc01@agccert.com.

### 3. TEST ENVIRONMENT

#### 3.1 ADDRESS OF THE TEST LABORATORY

Laboratory: Attestation of Global Compliance (Shenzhen) Co., Ltd.

Address: 1-2/F, Building 19, Junfeng Industrial Park, Chongqing Road, Heping Community, Fuhai Street, Bao'an District, Shenzhen, Guangdong, China

#### 3.2 TEST FACILITY

The test facility is recognized, certified, or accredited by the following organizations:

##### **CNAS-Lab Code: L5488**

Attestation of Global Compliance (Shenzhen) Co., Ltd. has been assessed and proved to be in compliance with CNAS-CL01 Accreditation Criteria for Testing and Calibration Laboratories (identical to ISO/IEC17025: 2017 General Requirements) for the Competence of Testing and Calibration Laboratories.

##### **A2LA-Lab Cert. No.: 5054.02**

Attestation of Global Compliance (Shenzhen) Co., Ltd. EMC Laboratory has been accredited by A2LA for technical competence in the field of electrical testing, and proved to be in compliance with ISO/IEC 17025: 2017 General Requirements for the Competence of Testing and Calibration Laboratories and any additional program requirements in the identified field of testing.

##### **FCC-Registration No.: 975832**

Attestation of Global Compliance (Shenzhen) Co., Ltd. EMC Laboratory has been registered and fully described in a report filed with the FCC (Federal Communications Commission). The acceptance letter from the FCC is maintained in our files with Registration 975832.

##### **IC-Registration No.: 24842 (CAB identifier: CN0063)**

Attestation of Global Compliance (Shenzhen) Co., Ltd. EMC Laboratory has been registered and fully described in a report filed with the Certification and Engineering Bureau of Industry Canada. The acceptance letter from the IC is maintained in our files with Registration 24842.

Any report having not been signed by authorized approver, or having been altered without authorization, or having not been stamped by the "Dedicated Testing/Inspection Stamp" is deemed to be invalid. Copying or excerpting portion of, or altering the content of the report is not permitted without the written authorization of AGC. The test results presented in the report apply only to the tested sample. Any objections to report issued by AGC should be submitted to AGC within 15days after the issuance of the test report. Further enquiry of validity or verification of the test report should be addressed to AGC by [agc01@agccert.com](mailto:agc01@agccert.com).

### 3.3 ENVIRONMENTAL CONDITIONS

	NORMAL CONDITIONS	EXTREME CONDITIONS
Temperature range (°C)	15 - 35	-20 - 50
Relative humidity range	20 % - 75 %	20 % - 75 %
Pressure range (kPa)	86 - 106	86 - 106
Power supply	DC 3.8V	DC 3.23V/DC 4.35V
Note: The Extreme Temperature and Extreme Voltages declared by the manufacturer.		

### 3.4 MEASUREMENT UNCERTAINTY

The reported uncertainty of measurement  $y \pm U$ , where expanded uncertainty  $U$  is based on a standard uncertainty multiplied by a coverage factor of  $k=2$ , providing a level of confidence of approximately 95%.

Item	Measurement Uncertainty
Uncertainty of Conducted Emission for AC Port	$U_c = \pm 3.1$ dB
Uncertainty of Radiated Emission below 1GHz	$U_c = \pm 4.0$ dB
Uncertainty of Radiated Emission above 1GHz	$U_c = \pm 4.8$ dB
Uncertainty of total RF power, conducted	$U_c = \pm 0.8$ dB
Uncertainty of RF power density, conducted	$U_c = \pm 2.6$ dB
Uncertainty of spurious emissions, conducted	$U_c = \pm 2$ %
Uncertainty of Occupied Channel Bandwidth	$U_c = \pm 2.7$ %

Any report having not been signed by authorized approver, or having been altered without authorization, or having not been stamped by the "Dedicated Testing/Inspection Stamp" is deemed to be invalid. Copying or excerpting portion of, or altering the content of the report is not permitted without the written authorization of AGC. The test results presented in the report apply only to the tested sample. Any objections to report issued by AGC should be submitted to AGC within 15days after the issuance of the test report. Further enquiry of validity or verification of the test report should be addressed to AGC by [agc01@agccert.com](mailto:agc01@agccert.com).

### 3.5 LIST OF EQUIPMENTS USED

#### TEST EQUIPMENT OF CONDUCTED EMISSION TEST

Equipment	Manufacturer	Model	S/N	Cal. Date	Cal. Due
TEST RECEIVER	R&S	ESPI	101206	Aug. 04, 2022	Aug. 03, 2023
LISN	R&S	ESH2-Z5	100086	Jun. 08, 2022	Jun. 07, 2023
Test software	R&S	ES-K1 (Ver.V1.71)	N/A	N/A	N/A

#### TEST EQUIPMENT OF RADIATED EMISSION TEST

Equipment	Manufacturer	Model	S/N	Cal. Date	Cal. Due
TEST RECEIVER	R&S	ESCI	10096	Feb. 18, 2023	Feb. 17, 2024
EXA Signal Analyzer	Aglient	N9010A	MY53470504	Aug. 04, 2022	Aug. 03, 2023
Power sensor	Aglient	U2021XA	MY54110007	Mar. 03, 2023	Mar. 02, 2024
5GHz Fliter	EM Electronics	5150-5880MHz	N/A	N/A	N/A
Attenuator	ZHINAN	E-002	N/A	Sep. 01, 2022	Aug. 31, 2023
Horn antenna	SCHWARZBECK	BBHA 9170	#768	Oct. 31, 2021	Oct. 30, 2023
Active loop antenna (9K-30MHZ)	ZHINAN	ZN30900C	18051	Mar. 12, 2022	Mar. 11, 2024
Double-Ridged Waveguide Horn	ETS LINDGREN	3117	00034609	Mar. 03, 2023	Mar. 02, 2024
Broadband Preamplifier	ETS LINDGREN	3117PA	00225134	N/A	N/A
ANTENNA	SCHWARZBECK	VULB9168	494	Jan. 05, 2023	Jan. 04, 2025
Test software	Tonscend	JS32-RE (Ver.2.5)	N/A	N/A	N/A

Any report having not been signed by authorized approver, or having been altered without authorization, or having not been stamped by the "Dedicated Testing/Inspection Stamp" is deemed to be invalid. Copying or excerpting portion of, or altering the content of the report is not permitted without the written authorization of AGC. The test results presented in the report apply only to the tested sample. Any objections to report issued by AGC should be submitted to AGC within 15days after the issuance of the test report. Further enquiry of validity or verification of the test report should be addressed to AGC by agc01@agccert.com.

#### 4. DESCRIPTION OF TEST MODES

Mode	Available channel	Tested channel	Modulation	Date rate (Mbps)
802.11a/n/ac	Refer to Section 2.2	36,40,48,52,60,64,100 116,140,149,157,165	OFDM/OFDMA	6Mbps/MCS0
802.11n/ac		38,46,54,62,102 110,134,151,159	OFDM/OFDMA	MCS0
802.11ac		42,58,106,121,155	OFDM/OFDMA	MCS0

**Note:**

1. The EUT has been set to operate continuously on tested channel individually, and the EUT is operating at its maximum duty cycle>or equal 98%.
2. All modes under which configure applicable have been tested and the worst mode test data recording in the test report, if no other mode data.
3. The test software is through engineering commands, EUT can be set to a separate test mode.

Any report having not been signed by authorized approver, or having been altered without authorization, or having not been stamped by the “Dedicated Testing/Inspection Stamp” is deemed to be invalid. Copying or excerpting portion of, or altering the content of the report is not permitted without the written authorization of AGC. The test results presented in the report apply only to the tested sample. Any objections to report issued by AGC should be submitted to AGC within 15days after the issuance of the test report. Further enquiry of validity or verification of the test report should be addressed to AGC by agc01@agccert.com.

## 5. SYSTEM TEST CONFIGURATION

### 5.1. CONFIGURATION OF EUT SYSTEM

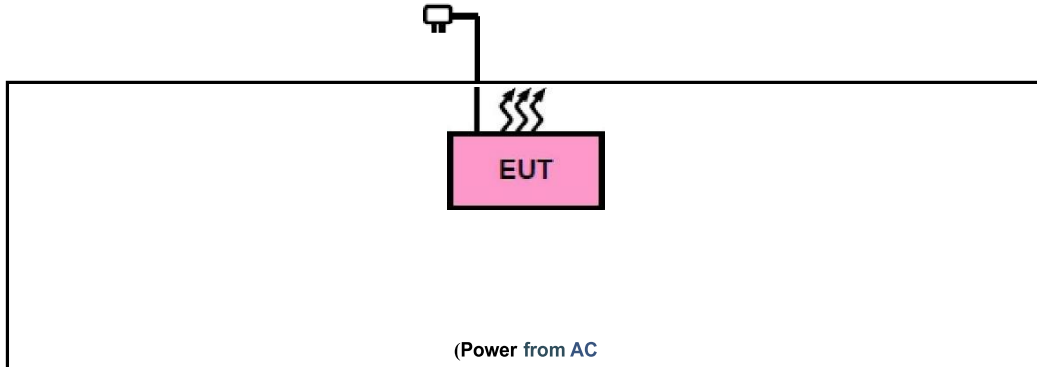

### 5.2. EQUIPMENT USED IN EUT SYSTEM

Item	Equipment	Model No.	ID or Specification	Remark
1	Smart tablet	AGM_PAD_P1	FCC ID: 2A3DR-PADP1	EUT
2	Battery	AGM_PAD_P1	DC 3.8V 7000mAh	Accessories
3	Adapter	U312E0A050200	Input: AC 100-240V 50/60Hz, 0.35A DC 5.0V 2A	Accessories
4	USB Cable	N/A	N/A	Accessories

### 5.3. SUMMARY OF TEST RESULTS

Item	FCC Rules	Description Of Test	Result
1	§15.203	Antenna Equipment	Pass
2	§15.407(a/1/2/3)	RF Output Power	Pass
3	§15.407(e)	6dB Bandwidth Measurement	Pass
4	§2.1049	26dB bandwidth Measurement	Pass
5	§15.407(a/1/2/3)	Power Spectral Density	Pass
6	§15.407(b)(1/2/3/4/5)	Conducted Spurious Emission	Pass
7	§15.209, §15.407(b)(1/2/3/4/5)	Radiated Emission & Band Edge	Pass
8	§15.207	AC Power Line Conducted Emission	Pass

Any report having not been signed by authorized approver, or having been altered without authorization, or having not been stamped by the "Dedicated Testing/Inspection Stamp" is deemed to be invalid. Copying or excerpting portion of, or altering the content of the report is not permitted without the written authorization of AGC. The test results presented in the report apply only to the tested sample. Any objections to report issued by AGC should be submitted to AGC within 15 days after the issuance of the test report. Further enquiry of validity or verification of the test report should be addressed to AGC by agc01@agccert.com.

## 6. RF OUTPUT POWER MEASUREMENT

### 6.1 MEASUREMENT LIMITS

Operation Band	EUT Category		LIMIT
U-NII-1	<input type="checkbox"/>	Outdoor Access Point	1 Watt (30 dBm) (Max. e.i.r.p < 125mW(21 dBm) at any elevation angle above 30 degrees as measured from the horizon)
	<input type="checkbox"/>	Fixed point-to-point Access Point	1 Watt (30 dBm)
	<input type="checkbox"/>	Indoor Access Point	1 Watt (30 dBm)
	<input checked="" type="checkbox"/>	Client devices	250mW (23.98 dBm)
U-NII-2A	/		250mW (23.98 dBm) or 11 dBm+10 log B*
U-NII-2C	/		250mW (23.98 dBm) or 11 dBm+10 log B*
U-NII-3	/		1 Watt (30 dBm)

Note: Where B is the 26dB emission bandwidth in MHz.

### 6.2 MEASUREMENT PROCEDURE

Method PM is Measurement using an RF average power meter. The procedure for this method is as follows:

1. The testing follows the ANSI C63.10 Section 12.3.3.1
2. Measurements may be performed using a wideband RF power meter with a thermocouple detector or equivalent if all of the following conditions are satisfied:
3. The EUT is configured to transmit continuously, or to transmit with a constant duty cycle.
4. At all times when the EUT is transmitting, it shall be transmitting at its maximum power control level.
5. The integration period of the power meter exceeds the repetition period of the transmitted signal by at least a factor of five.
6. Determine according to the duty cycle of the equipment: when it is less than 98%, follow the steps below.
7. Measure the average power of the transmitter. This measurement is an average over both the ON and OFF periods of the transmitter.
8. Adjust the measurement in dBm by adding  $[10 \log (1 / D)]$ , where D is the duty cycle {e.g.,  $[10 \log (1 / 0.25)]$ , if the duty cycle is 25%}.
9. Record the test results in the report.

Any report having not been signed by authorized approver, or having been altered without authorization, or having not been stamped by the "Dedicated Testing/Inspection Stamp" is deemed to be invalid. Copying or excerpting portion of, or altering the content of the report is not permitted without the written authorization of AGC. The test results presented in the report apply only to the tested sample. Any objections to report issued by AGC should be submitted to AGC within 15days after the issuance of the test report. Further enquiry of validity or verification of the test report should be addressed to AGC by agc01@agccert.com.



### 6.3 MEASUREMENT SETUP (BLOCK DIAGRAM OF CONFIGURATION)

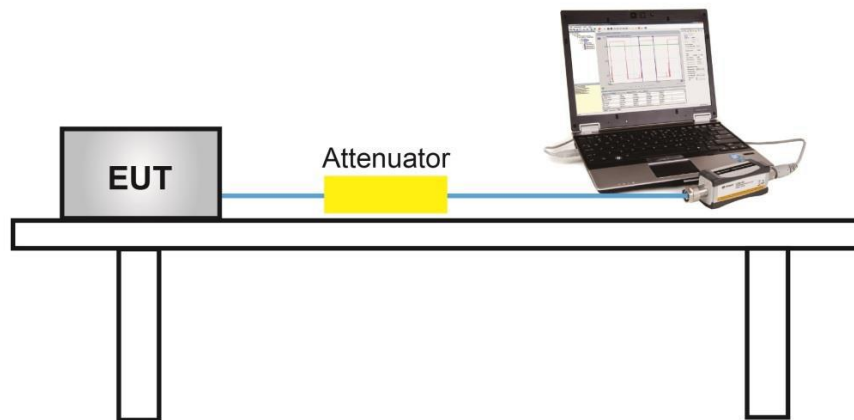

### 6.4 MEASUREMENT RESULT

Test Data of Conducted Output Power for band 5.15-5.25 GHz				
Test Mode	Test Channel (MHz)	Average Power (dBm)	Limits (dBm)	Pass or Fail
802.11a	5180	10.36	23.98	Pass
	5200	9.98	23.98	Pass
	5240	9.53	23.98	Pass
802.11n20	5180	10.18	23.98	Pass
	5200	9.90	23.98	Pass
	5240	9.41	23.98	Pass
802.11n40	5190	10.23	23.98	Pass
	5230	9.77	23.98	Pass
802.11ac20	5180	9.85	23.98	Pass
	5200	9.83	23.98	Pass
	5240	9.35	23.98	Pass
802.11ac40	5190	10.33	23.98	Pass
	5230	9.84	23.98	Pass
802.11ac80	5210	10.58	23.98	Pass

Any report having not been signed by authorized approver, or having been altered without authorization, or having not been stamped by the "Dedicated Testing/Inspection Stamp" is deemed to be invalid. Copying or excerpting portion of, or altering the content of the report is not permitted without the written authorization of AGC. The test results presented in the report apply only to the tested sample. Any objections to report issued by AGC should be submitted to AGC within 15days after the issuance of the test report. Further enquiry of validity or verification of the test report should be addressed to AGC by agc01@agccert.com.

Test Data of Conducted Output Power for band 5.25-5.35 GHz				
Test Mode	Test Channel (MHz)	Average Power (dBm)	Limits (dBm)	Pass or Fail
802.11a	5260	9.36	23.98	Pass
	5300	8.50	23.98	Pass
	5320	8.35	23.98	Pass
802.11n20	5260	8.87	23.98	Pass
	5300	8.52	23.98	Pass
	5320	8.29	23.98	Pass
802.11n40	5270	9.00	23.98	Pass
	5310	8.60	23.98	Pass
802.11ac20	5260	8.89	23.98	Pass
	5300	8.46	23.98	Pass
	5320	8.30	23.98	Pass
802.11ac40	5270	9.02	23.98	Pass
	5310	8.62	23.98	Pass
802.11ac80	5290	9.08	23.98	Pass

Any report having not been signed by authorized approver, or having been altered without authorization, or having not been stamped by the "Dedicated Testing/Inspection Stamp" is deemed to be invalid. Copying or excerpting portion of, or altering the content of the report is not permitted without the written authorization of AGC. The test results presented in the report apply only to the tested sample. Any objections to report issued by AGC should be submitted to AGC within 15days after the issuance of the test report. Further enquiry of validity or verification of the test report should be addressed to AGC by agc01@agccert.com.

Test Data of Conducted Output Power for band 5.470-5.725 GHz				
Test Mode	Test Channel (MHz)	Average Power (dBm)	Limits (dBm)	Pass or Fail
802.11a	5500	10.10	23.98	Pass
	5600	9.65	23.98	Pass
	5700	8.07	23.98	Pass
802.11n20	5500	9.99	23.98	Pass
	5600	9.49	23.98	Pass
	5700	8.00	23.98	Pass
802.11n40	5510	10.37	23.98	Pass
	5590	10.03	23.98	Pass
	5670	8.39	23.98	Pass
802.11ac20	5500	10.11	23.98	Pass
	5600	9.47	23.98	Pass
	5700	7.93	23.98	Pass
802.11ac40	5510	10.44	23.98	Pass
	5590	9.93	23.98	Pass
	5670	8.24	23.98	Pass
802.11ac80	5530	10.79	23.98	Pass
	5610	10.01	23.98	Pass

Test Data of Conducted Output Power for band 5.725-5.850 GHz				
Test Mode	Test Channel (MHz)	Average Power (dBm)	Limits (dBm)	Pass or Fail
802.11a	5745	8.35	30	Pass
	5785	8.77	30	Pass
	5825	8.93	30	Pass
802.11n20	5745	8.30	30	Pass
	5785	8.57	30	Pass
	5825	8.83	30	Pass
802.11n40	5755	8.77	30	Pass
	5795	8.83	30	Pass
802.11ac20	5745	8.22	30	Pass
	5785	8.54	30	Pass
	5825	8.75	30	Pass
802.11ac40	5755	8.56	30	Pass
	5795	8.83	30	Pass
802.11ac80	5775	8.96	30	Pass

Any report having not been signed by authorized approver, or having been altered without authorization, or having not been stamped by the "Dedicated Testing/Inspection Stamp" is deemed to be invalid. Copying or excerpting portion of, or altering the content of the report is not permitted without the written authorization of AGC. The test results presented in the report apply only to the tested sample. Any objections to report issued by AGC should be submitted to AGC within 15days after the issuance of the test report. Further enquiry of validity or verification of the test report should be addressed to AGC by agc01@agccert.com.

## 7. 6DB&26DB BANDWIDTH MEASUREMENT

### 7.1 MEASUREMENT LIMITS

The minimum 6dB bandwidth shall be at least 500 kHz.

### 7.2 MEASUREMENT PROCEDURE

7.2.1 -6dB bandwidth (DTS bandwidth) Test setting:

1. Connect EUT RF output port to the Spectrum Analyzer through an RF attenuator
2. Set the EUT Work on operation frequency individually.
3. Set RBW = 100kHz.
4. Set the VBW  $\geq 3 \times$  RBW. Detector = Peak. Trace mode = max hold.
5. Measure the maximum width of the emission that is 6 dB down from the peak of the emission.

7.2.2 99% occupied bandwidth test setting:

1. Connect EUT RF output port to the Spectrum Analyzer through an RF attenuator
2. Set the EUT Work on the top, the middle and the bottom operation frequency individually.
3. Set Span = approximately 1.5 to 5 times the OBW, centered on a nominal channel  
The nominal IF filter bandwidth (3 dB RBW) shall be in the range of 1% to 5% of the OBW and video bandwidth (VBW) shall be approximately three times RBW; Sweep = auto; Detector function = peak
4. Set SPA Trace 1 Max hold, then View.

7.2.3 -26dB Bandwidth test setting:

1. Set RBW = approximately 1% of the emission bandwidth.
2. Set the VBW > RBW.
3. Detector = Peak.
4. Trace mode = max hold.
5. Measure the maximum width of the emission that is 26 dB down from the maximum of the emission.  
Compare this with the RBW setting of the analyzer. Readjust RBW and repeat measurement as needed until the RBW/EBW ratio is approximately 1%.

**Note:** The EUT was tested according to KDB 789033 for compliance to FCC 47CFR 15.407 requirements.

### 7.3 MEASUREMENT SETUP (BLOCK DIAGRAM OF CONFIGURATION)

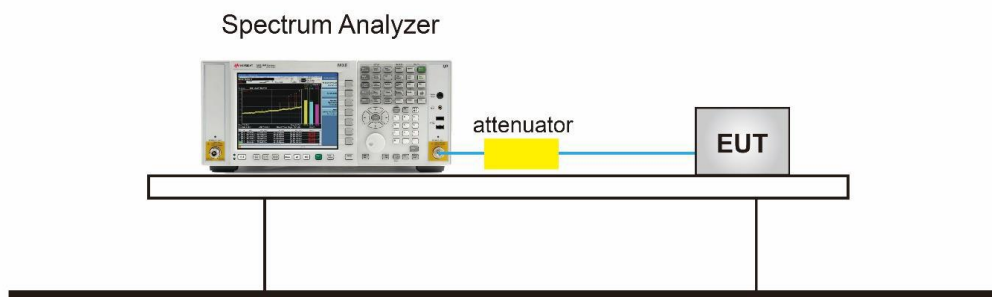

Any report having not been signed by authorized approver, or having been altered without authorization, or having not been stamped by the "Dedicated Testing/Inspection Stamp" is deemed to be invalid. Copying or excerpting portion of, or altering the content of the report is not permitted without the written authorization of AGC. The test results presented in the report apply only to the tested sample. Any objections to report issued by AGC should be submitted to AGC within 15days after the issuance of the test report. Further enquiry of validity or verification of the test report should be addressed to AGC by agc01@agccert.com.

#### 7.4 MEASUREMENT RESULTS

Test Data of Occupied Bandwidth and -26dB Bandwidth for band 5.15-5.25 GHz					
Test Mode	Test Channel (MHz)	99% Occupied Bandwidth (MHz)	-26dB Bandwidth (MHz)	Limits (MHz)	Pass or Fail
802.11a	5180	16.384	19.552	N/A	Pass
	5200	16.449	20.043	N/A	Pass
	5240	16.427	19.900	N/A	Pass
802.11n20	5180	17.562	20.190	N/A	Pass
	5200	17.582	20.140	N/A	Pass
	5240	17.599	20.014	N/A	Pass
802.11n40	5190	35.966	40.633	N/A	Pass
	5230	35.972	40.121	N/A	Pass
802.11ac20	5180	17.554	20.027	N/A	Pass
	5200	17.569	20.128	N/A	Pass
	5240	17.561	20.037	N/A	Pass
802.11ac40	5190	35.946	39.783	N/A	Pass
	5230	35.894	39.758	N/A	Pass
802.11ac80	5210	75.298	89.578	N/A	Pass

Any report having not been signed by authorized approver, or having been altered without authorization, or having not been stamped by the "Dedicated Testing/Inspection Stamp" is deemed to be invalid. Copying or excerpting portion of, or altering the content of the report is not permitted without the written authorization of AGC. The test results presented in the report apply only to the tested sample. Any objections to report issued by AGC should be submitted to AGC within 15days after the issuance of the test report. Further enquiry of validity or verification of the test report should be addressed to AGC by agc01@agccert.com.

Test Data of Occupied Bandwidth and -26dB Bandwidth for band 5.25-5.35 GHz					
Test Mode	Test Channel (MHz)	99% Occupied Bandwidth (MHz)	-26dB Bandwidth (MHz)	Limits (MHz)	Pass or Fail
802.11a	5260	16.433	20.273	N/A	Pass
	5300	16.452	19.616	N/A	Pass
	5320	16.438	19.643	N/A	Pass
802.11n20	5260	17.586	20.366	N/A	Pass
	5300	17.582	20.630	N/A	Pass
	5320	17.571	20.091	N/A	Pass
802.11n40	5270	36.019	45.243	N/A	Pass
	5310	36.007	40.777	N/A	Pass
802.11ac20	5260	17.554	20.016	N/A	Pass
	5300	17.535	19.984	N/A	Pass
	5320	17.558	20.020	N/A	Pass
802.11ac40	5270	35.999	40.195	N/A	Pass
	5310	35.984	40.388	N/A	Pass
802.11ac80	5290	75.358	80.478	N/A	Pass

Any report having not been signed by authorized approver, or having been altered without authorization, or having not been stamped by the "Dedicated Testing/Inspection Stamp" is deemed to be invalid. Copying or excerpting portion of, or altering the content of the report is not permitted without the written authorization of AGC. The test results presented in the report apply only to the tested sample. Any objections to report issued by AGC should be submitted to AGC within 15days after the issuance of the test report. Further enquiry of validity or verification of the test report should be addressed to AGC by agc01@agccert.com.

Test Data of Occupied Bandwidth and -26dB Bandwidth for band 5.47-5.725 GHz					
Test Mode	Test Channel (MHz)	99% Occupied Bandwidth (MHz)	-26dB Bandwidth (MHz)	Limits (MHz)	Pass or Fail
802.11a	5500	16.405	19.832	N/A	Pass
	5600	16.388	19.653	N/A	Pass
	5700	16.459	19.727	N/A	Pass
802.11n20	5500	17.536	19.994	N/A	Pass
	5600	17.595	20.020	N/A	Pass
	5700	17.589	20.692	N/A	Pass
802.11n40	5510	35.951	40.698	N/A	Pass
	5590	35.944	40.707	N/A	Pass
	5670	36.050	49.338	N/A	Pass
802.11ac20	5500	17.523	20.112	N/A	Pass
	5600	17.575	20.239	N/A	Pass
	5700	17.573	20.138	N/A	Pass
802.11ac40	5510	35.971	40.163	N/A	Pass
	5590	35.909	40.418	N/A	Pass
	5670	36.015	40.336	N/A	Pass
802.11ac80	5530	75.246	80.261	N/A	Pass
	5610	75.169	80.225	N/A	Pass

Any report having not been signed by authorized approver, or having been altered without authorization, or having not been stamped by the "Dedicated Testing/Inspection Stamp" is deemed to be invalid. Copying or excerpting portion of, or altering the content of the report is not permitted without the written authorization of AGC. The test results presented in the report apply only to the tested sample. Any objections to report issued by AGC should be submitted to AGC within 15days after the issuance of the test report. Further enquiry of validity or verification of the test report should be addressed to AGC by agc01@agccert.com.

Test Data of Occupied Bandwidth and DTS Bandwidth for band 5.725-5.85 GHz					
Test Mode	Test Channel (MHz)	99% Occupied Bandwidth (MHz)	DTS Bandwidth (MHz)	Limits (MHz)	Pass or Fail
802.11a	5745	16.454	15.129	0.5	Pass
	5785	16.440	15.039	0.5	Pass
	5825	16.438	15.145	0.5	Pass
802.11n20	5745	17.581	15.130	0.5	Pass
	5785	17.563	15.119	0.5	Pass
	5825	17.571	15.072	0.5	Pass
802.11n40	5755	36.032	35.101	0.5	Pass
	5795	36.043	35.099	0.5	Pass
802.11ac20	5745	17.544	15.038	0.5	Pass
	5785	17.566	15.078	0.5	Pass
	5825	17.536	15.089	0.5	Pass
802.11ac40	5755	35.980	35.097	0.5	Pass
	5795	35.985	35.105	0.5	Pass
802.11ac80	5775	75.517	75.132	0.5	Pass

Any report having not been signed by authorized approver, or having been altered without authorization, or having not been stamped by the "Dedicated Testing/Inspection Stamp" is deemed to be invalid. Copying or excerpting portion of, or altering the content of the report is not permitted without the written authorization of AGC. The test results presented in the report apply only to the tested sample. Any objections to report issued by AGC should be submitted to AGC within 15days after the issuance of the test report. Further enquiry of validity or verification of the test report should be addressed to AGC by agc01@agccert.com.



**Test Graphs of Occupied Bandwidth and -26dB Bandwidth for band 5.15-5.25 GHz**

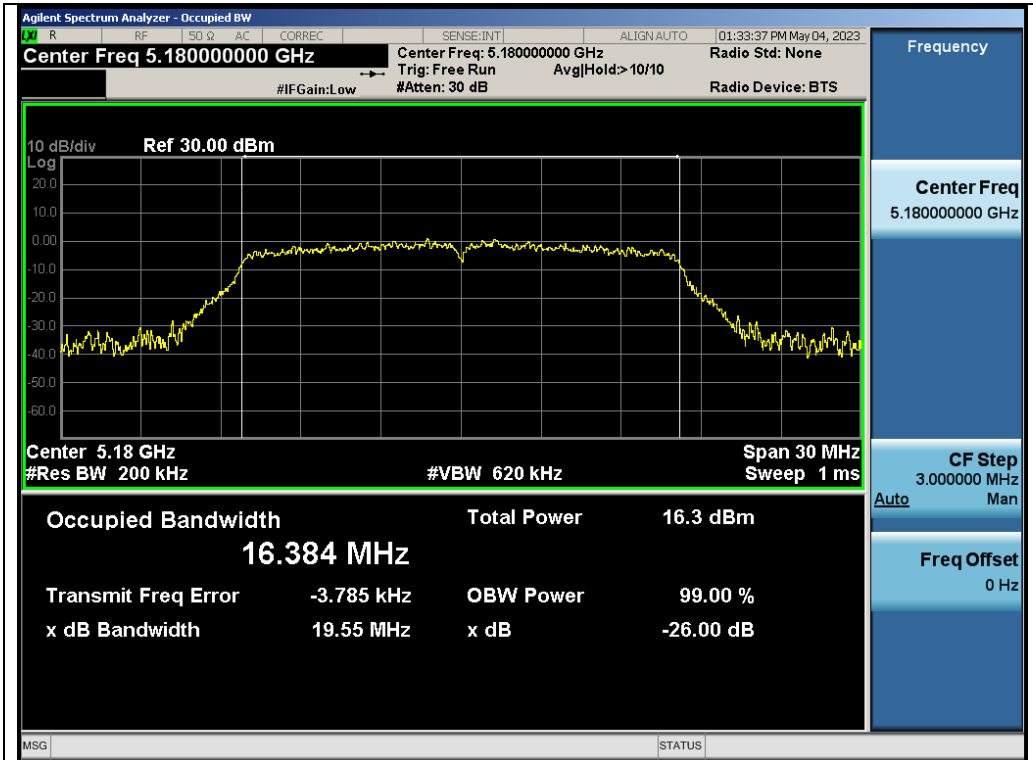

Test\_Graph\_802.11a\_ANT1\_5180\_6Mbps\_OBW

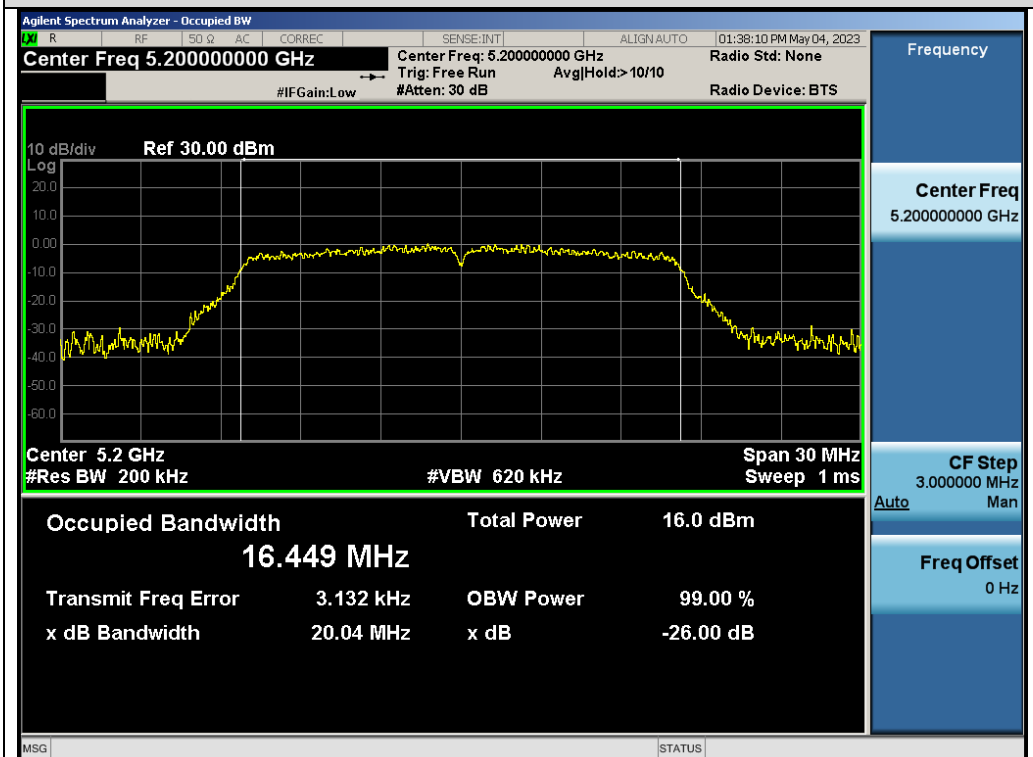

Test\_Graph\_802.11a\_ANT1\_5200\_6Mbps\_OBW

Any report having not been signed by authorized approver, or having been altered without authorization, or having not been stamped by the "Dedicated Testing/Inspection Stamp" is deemed to be invalid. Copying or excerpting portion of, or altering the content of the report is not permitted without the written authorization of AGC. The test results presented in the report apply only to the tested sample. Any objections to report issued by AGC should be submitted to AGC within 15days after the issuance of the test report. Further enquiry of validity or verification of the test report should be addressed to AGC by agc01@agccert.com.

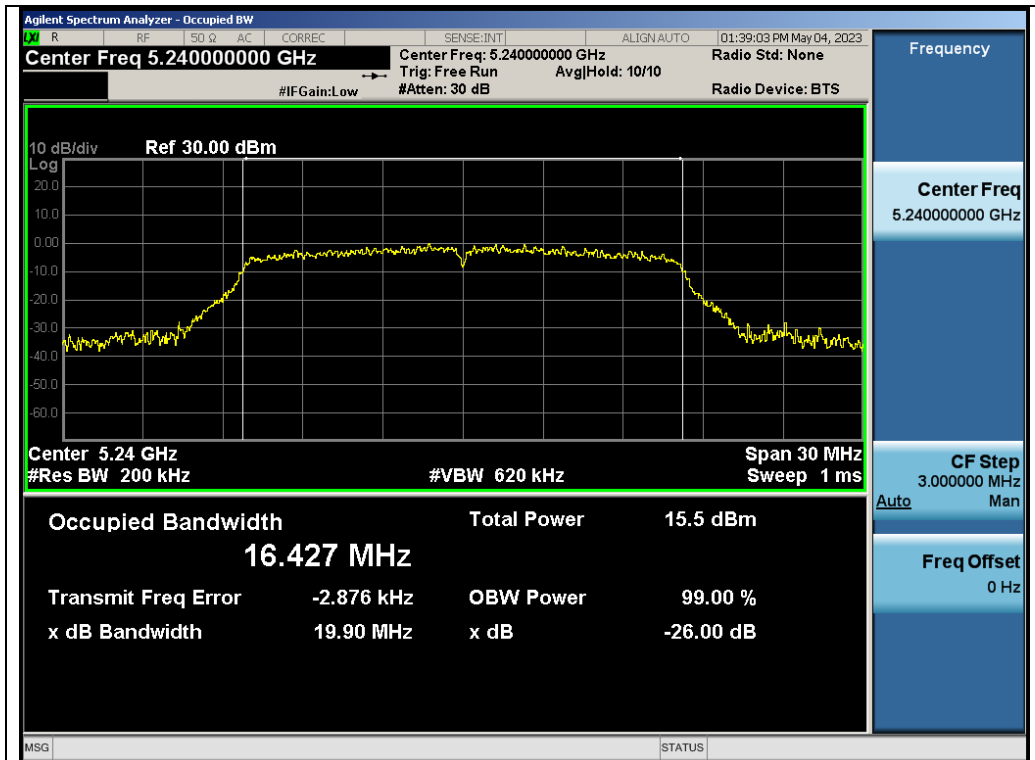

Test\_Graph\_802.11a\_ANT1\_5240\_6Mbps\_OBW

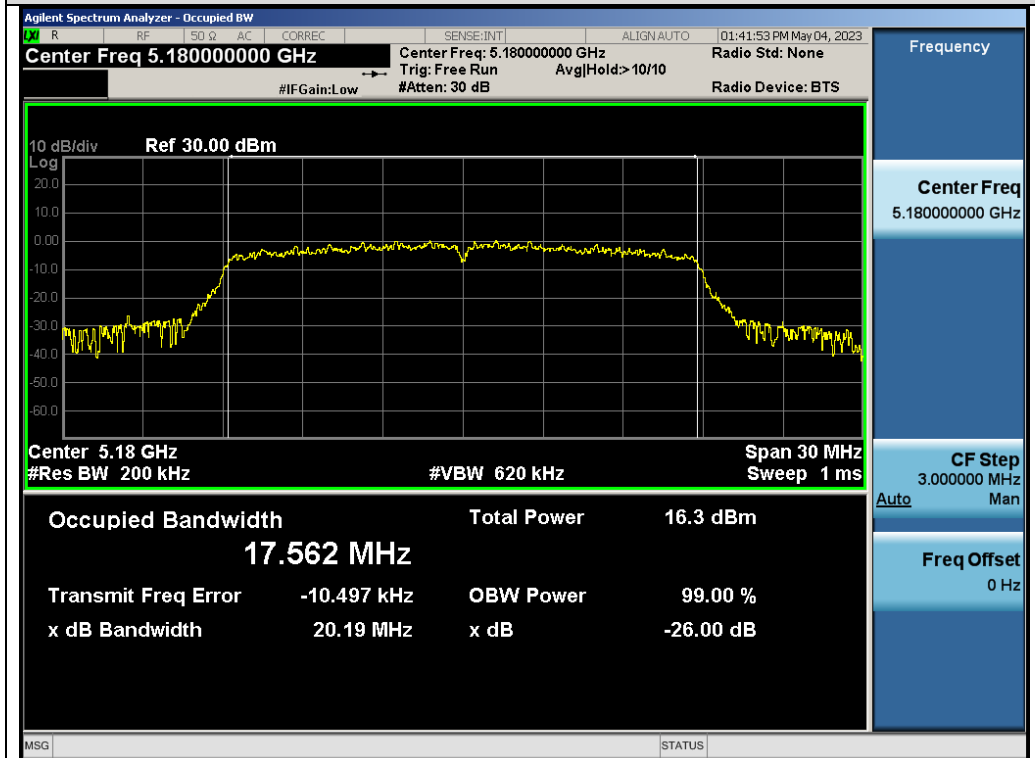

Test\_Graph\_802.11n20\_ANT1\_5180\_MCS0\_OBW

Any report having not been signed by authorized approver, or having been altered without authorization, or having not been stamped by the "Dedicated Testing/Inspection Stamp" is deemed to be invalid. Copying or excerpting portion of, or altering the content of the report is not permitted without the written authorization of AGC. The test results presented in the report apply only to the tested sample. Any objections to report issued by AGC should be submitted to AGC within 15 days after the issuance of the test report. Further enquiry of validity or verification of the test report should be addressed to AGC by agc01@agccert.com.

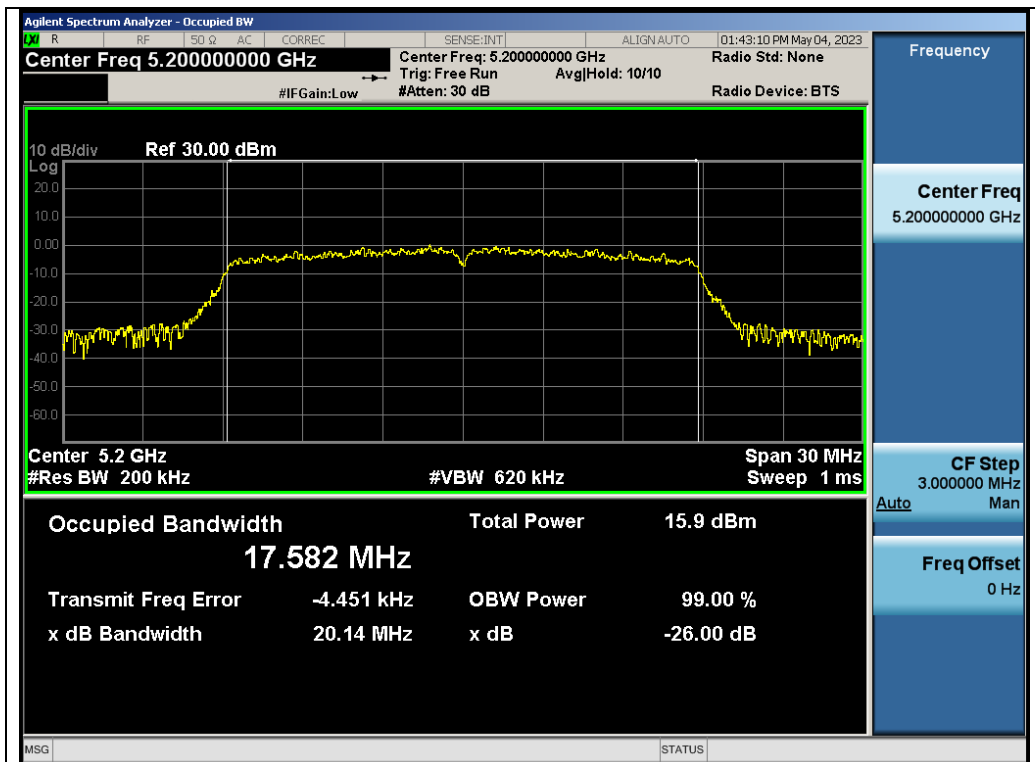

Test\_Graph\_802.11n20\_ANT1\_5200\_MCS0\_OBW

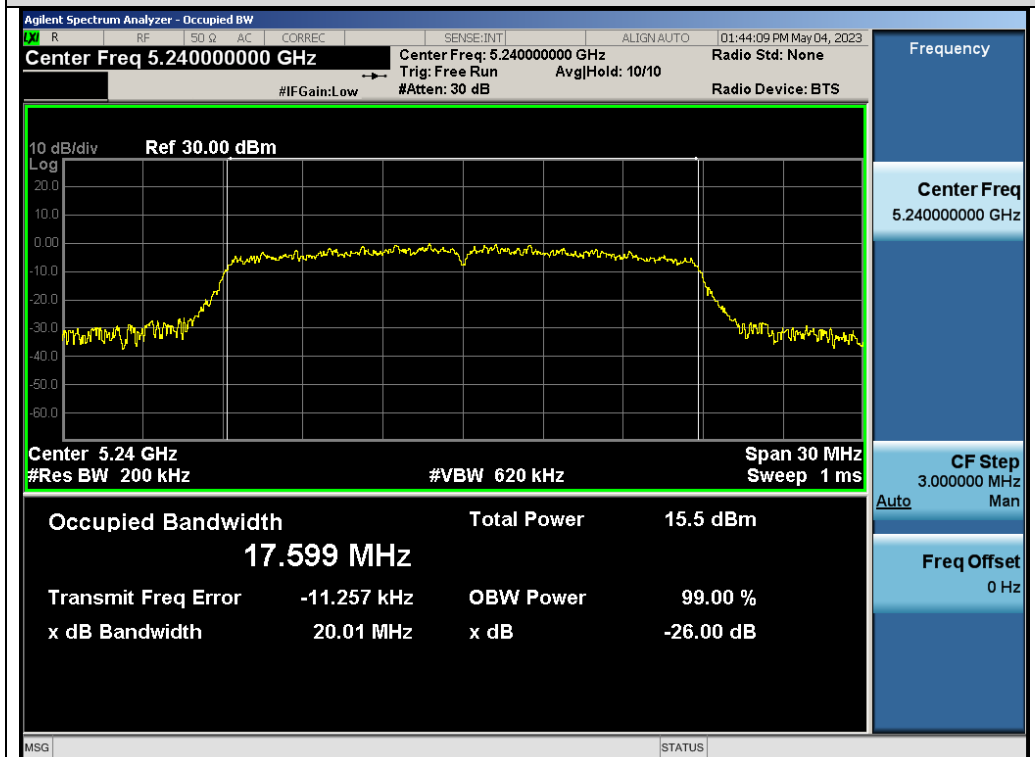

Test\_Graph\_802.11n20\_ANT1\_5240\_MCS0\_OBW

Any report having not been signed by authorized approver, or having been altered without authorization, or having not been stamped by the "Dedicated Testing/Inspection Stamp" is deemed to be invalid. Copying or excerpting portion of, or altering the content of the report is not permitted without the written authorization of AGC. The test results presented in the report apply only to the tested sample. Any objections to report issued by AGC should be submitted to AGC within 15days after the issuance of the test report. Further enquiry of validity or verification of the test report should be addressed to AGC by agc01@agccert.com.

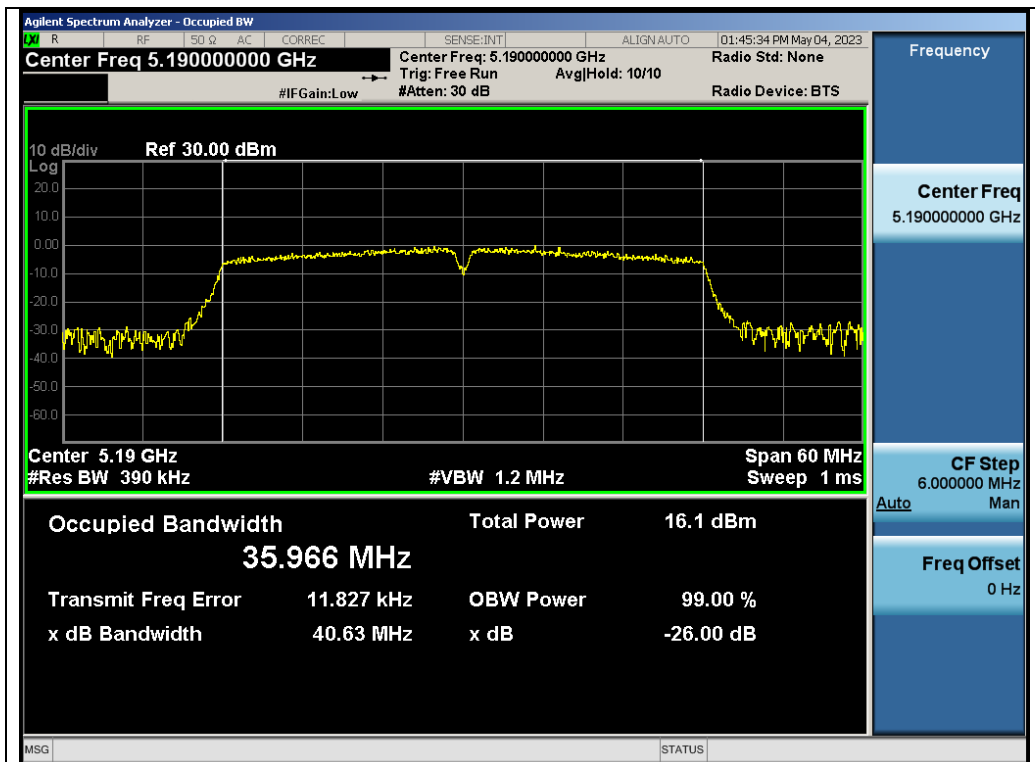

Test\_Graph\_802.11n40\_ANT1\_5190\_MCS0\_OBW

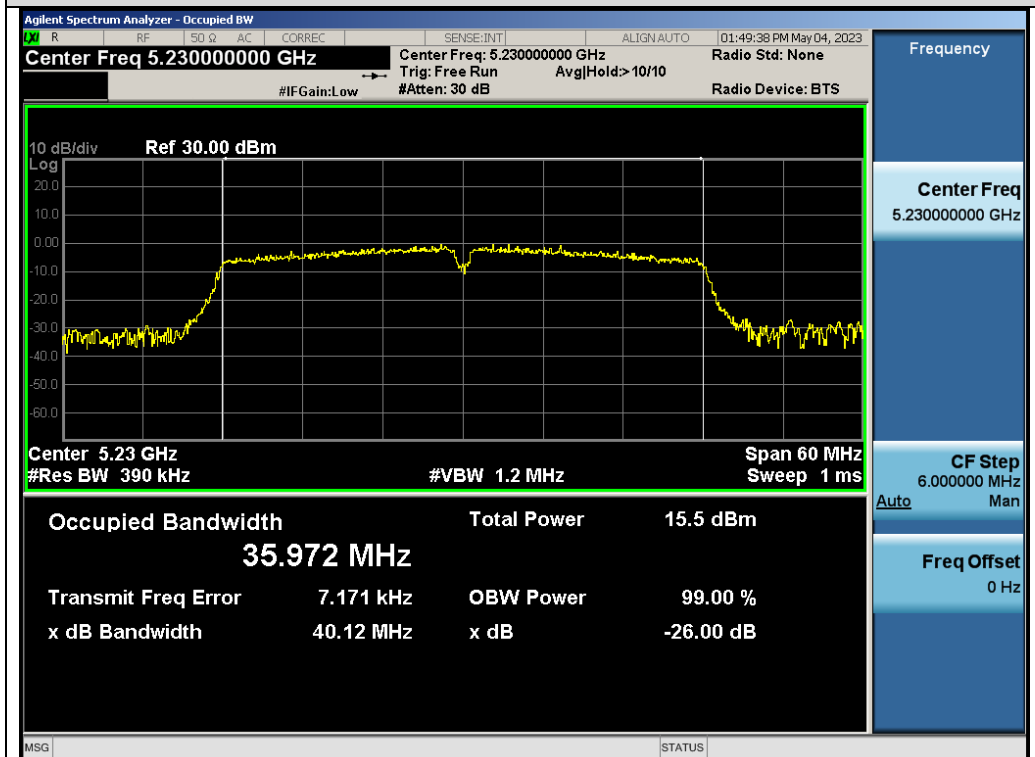

Test\_Graph\_802.11n40\_ANT1\_5230\_MCS0\_OBW

Any report having not been signed by authorized approver, or having been altered without authorization, or having not been stamped by the "Dedicated Testing/Inspection Stamp" is deemed to be invalid. Copying or excerpting portion of, or altering the content of the report is not permitted without the written authorization of AGC. The test results presented in the report apply only to the tested sample. Any objections to report issued by AGC should be submitted to AGC within 15days after the issuance of the test report. Further enquiry of validity or verification of the test report should be addressed to AGC by agc01@agccert.com.

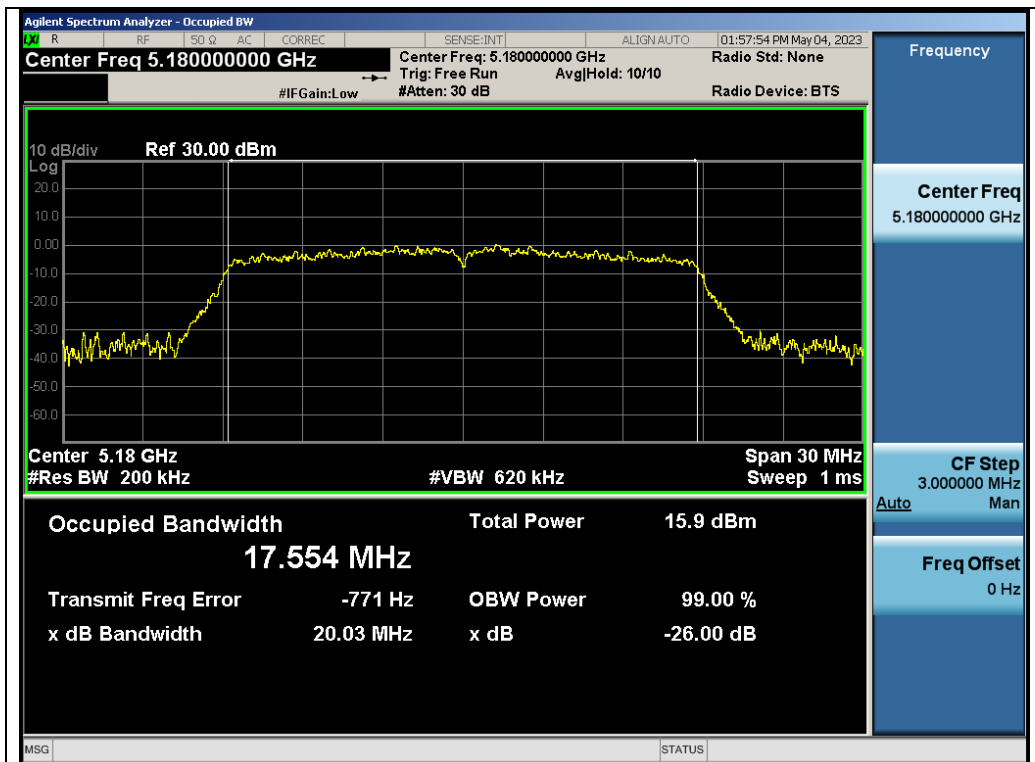

Test\_Graph\_802.11ac20\_ANT1\_5180\_MCS0\_OBW

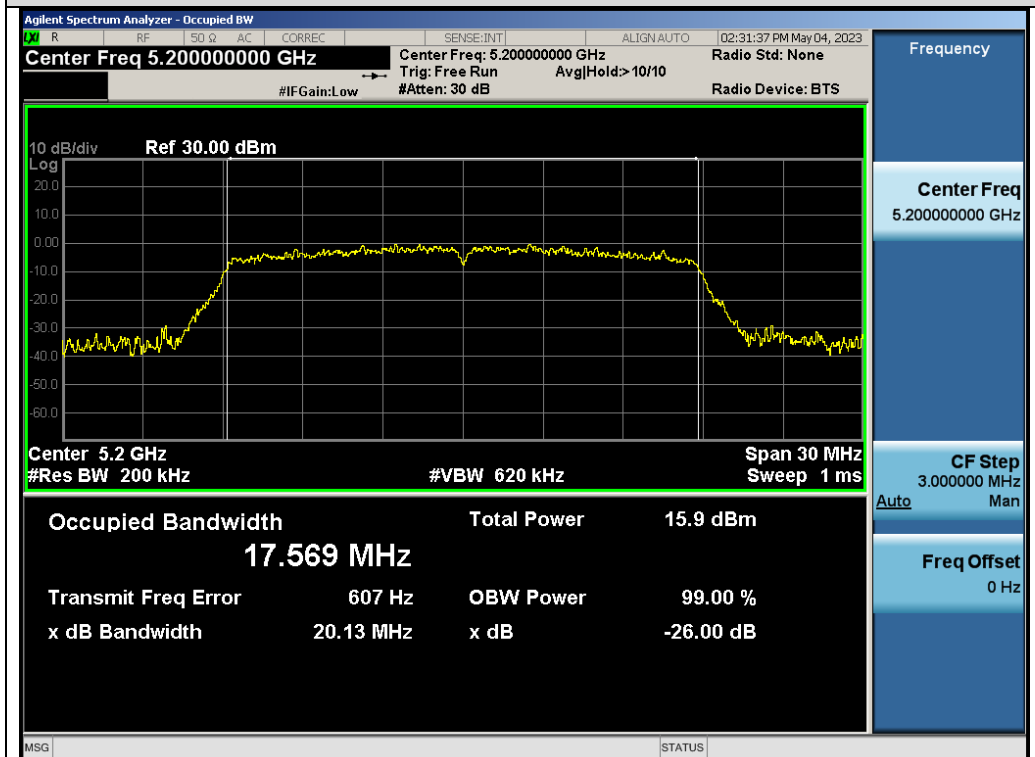

Test\_Graph\_802.11ac20\_ANT1\_5200\_MCS0\_OBW

Any report having not been signed by authorized approver, or having been altered without authorization, or having not been stamped by the "Dedicated Testing/Inspection Stamp" is deemed to be invalid. Copying or excerpting portion of, or altering the content of the report is not permitted without the written authorization of AGC. The test results presented in the report apply only to the tested sample. Any objections to report issued by AGC should be submitted to AGC within 15days after the issuance of the test report. Further enquiry of validity or verification of the test report should be addressed to AGC by agc01@agccert.com.

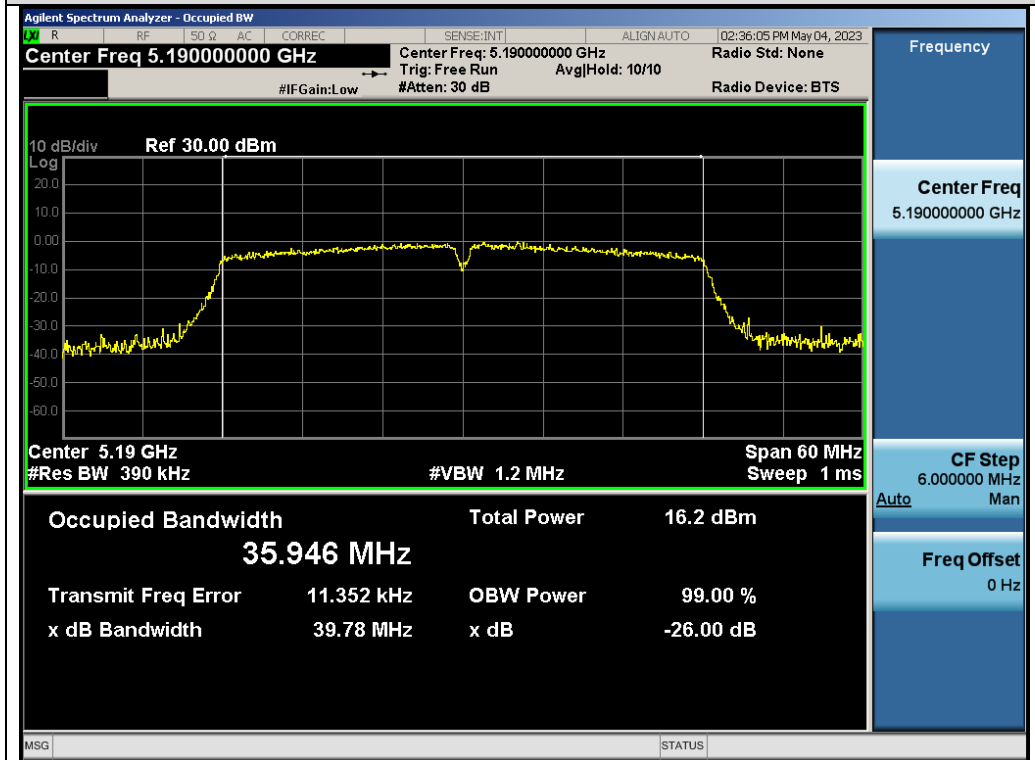
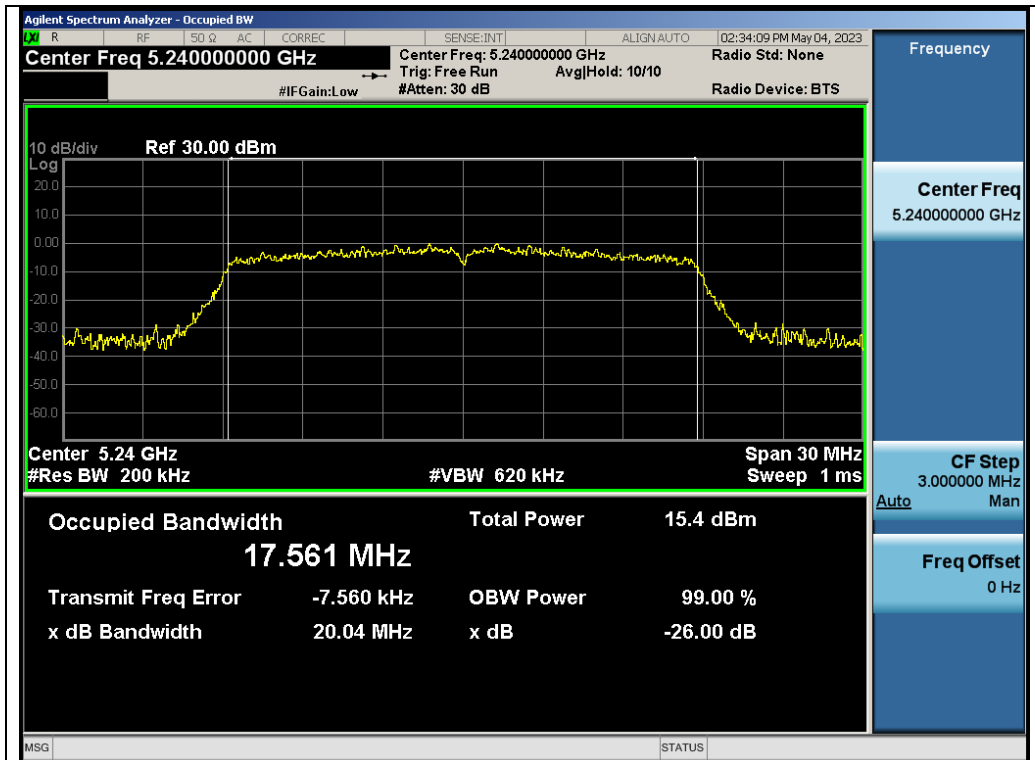

Any report having not been signed by authorized approver, or having been altered without authorization, or having not been stamped by the "Dedicated Testing/Inspection Stamp" is deemed to be invalid. Copying or excerpting portion of, or altering the content of the report is not permitted without the written authorization of AGC. The test results presented in the report apply only to the tested sample. Any objections to report issued by AGC should be submitted to AGC within 15days after the issuance of the test report. Further enquiry of validity or verification of the test report should be addressed to AGC by agc01@agccert.com.

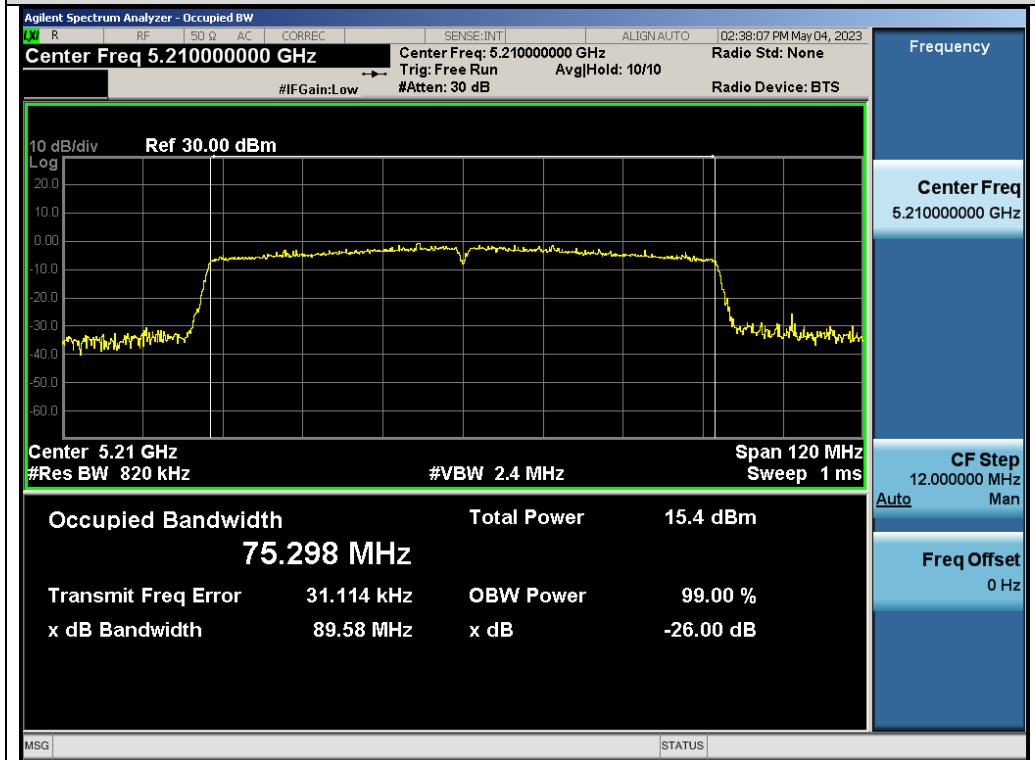
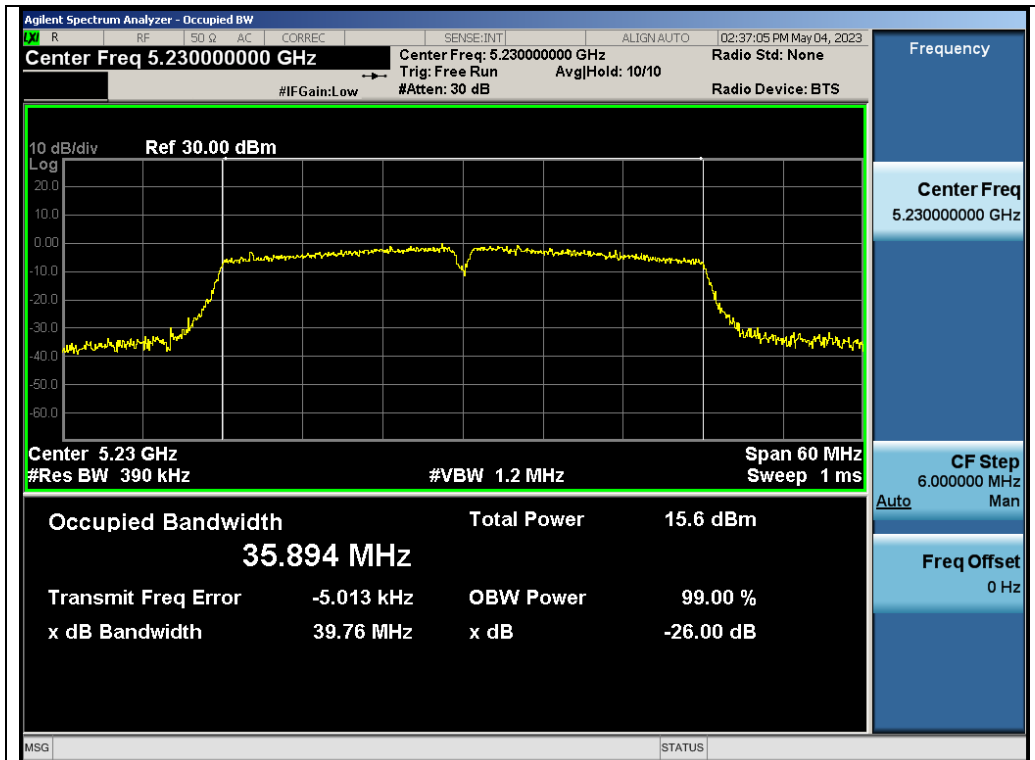

Any report having not been signed by authorized approver, or having been altered without authorization, or having not been stamped by the "Dedicated Testing/Inspection Stamp" is deemed to be invalid. Copying or excerpting portion of, or altering the content of the report is not permitted without the written authorization of AGC. The test results presented in the report apply only to the tested sample. Any objections to report issued by AGC should be submitted to AGC within 15days after the issuance of the test report. Further enquiry of validity or verification of the test report should be addressed to AGC by agc01@agccert.com.



### Test Graphs of Occupied Bandwidth for band 5.25-5.35 GHz

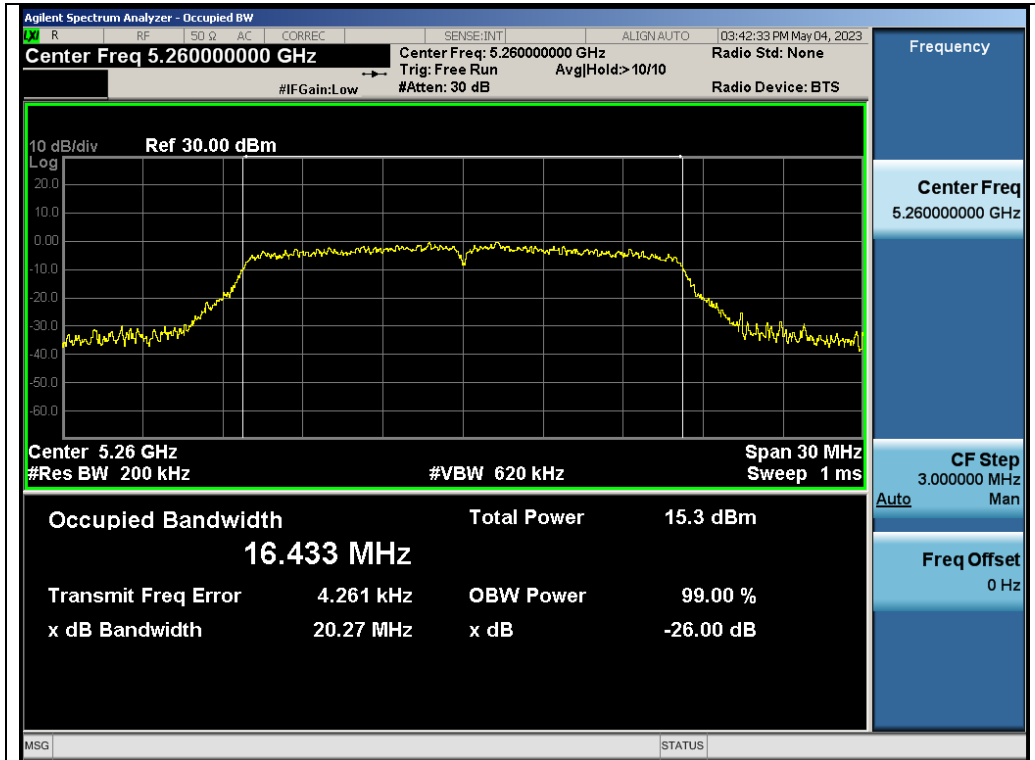

Test\_Graph\_802.11a\_ANT1\_5260\_6Mbps\_OBW

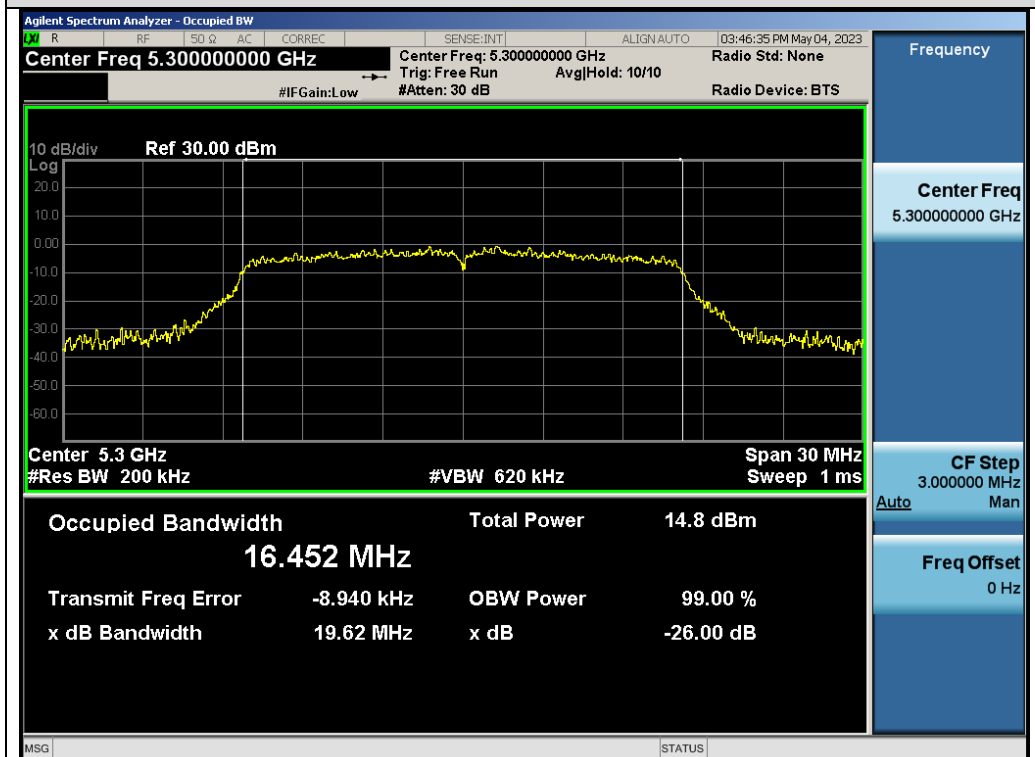

Test\_Graph\_802.11a\_ANT1\_5300\_6Mbps\_OBW

Any report having not been signed by authorized approver, or having been altered without authorization, or having not been stamped by the "Dedicated Testing/Inspection Stamp" is deemed to be invalid. Copying or excerpting portion of, or altering the content of the report is not permitted without the written authorization of AGC. The test results presented in the report apply only to the tested sample. Any objections to report issued by AGC should be submitted to AGC within 15days after the issuance of the test report. Further enquiry of validity or verification of the test report should be addressed to AGC by agc01@agccert.com.



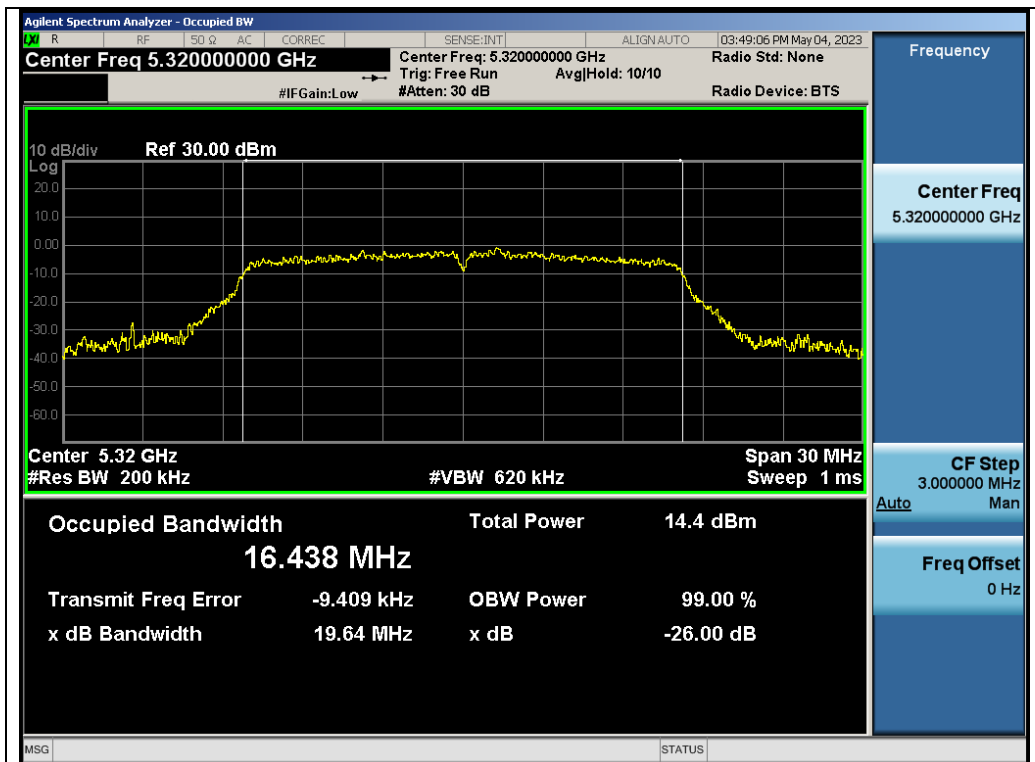

Test\_Graph\_802.11a\_ANT1\_5320\_6Mbps\_OBW

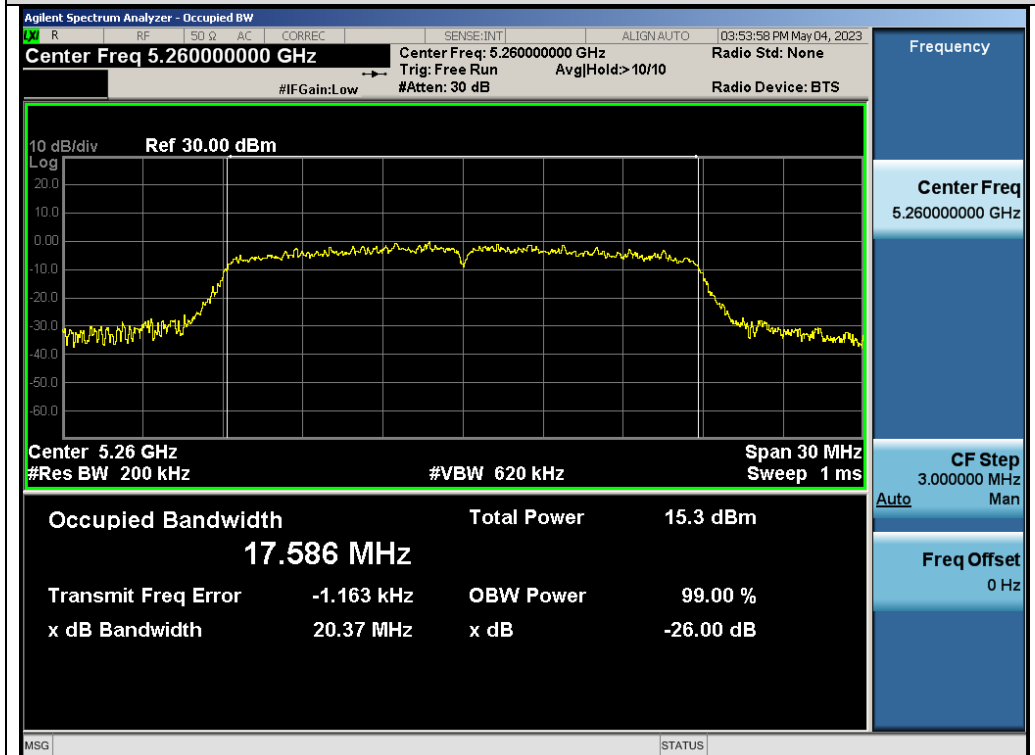

Test\_Graph\_802.11n20\_ANT1\_5260\_MCS0\_OBW

Any report having not been signed by authorized approver, or having been altered without authorization, or having not been stamped by the "Dedicated Testing/Inspection Stamp" is deemed to be invalid. Copying or excerpting portion of, or altering the content of the report is not permitted without the written authorization of AGC. The test results presented in the report apply only to the tested sample. Any objections to report issued by AGC should be submitted to AGC within 15days after the issuance of the test report. Further enquiry of validity or verification of the test report should be addressed to AGC by agc01@agccert.com.

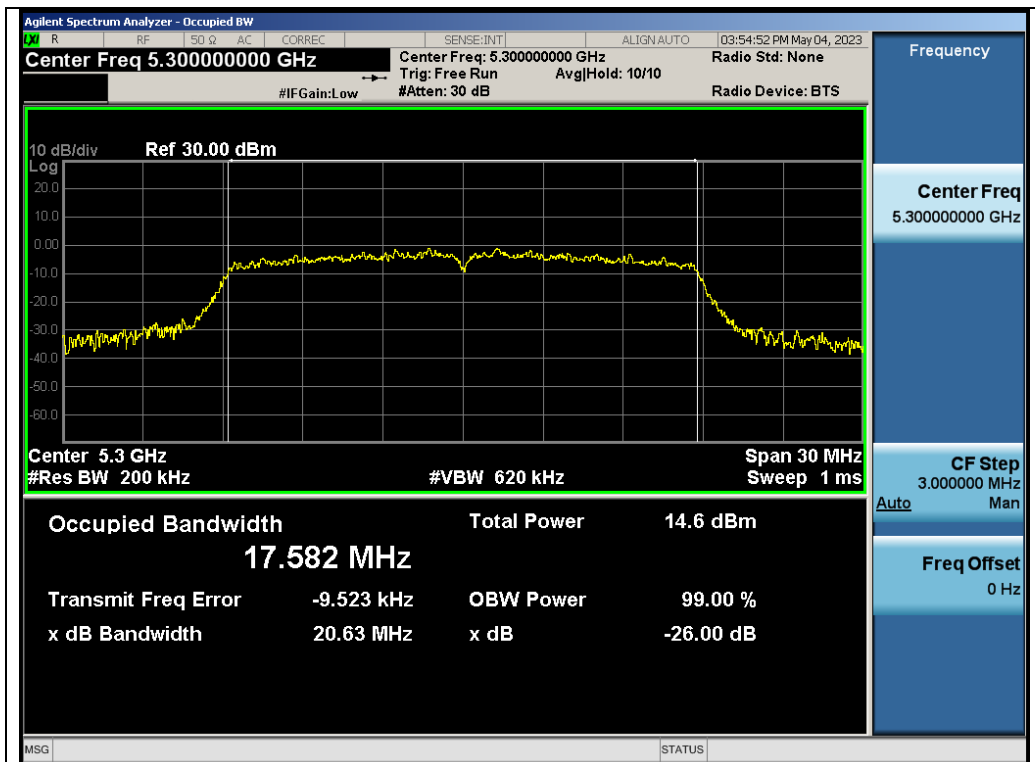

Test\_Graph\_802.11n20\_ANT1\_5300\_MCS0\_OBW

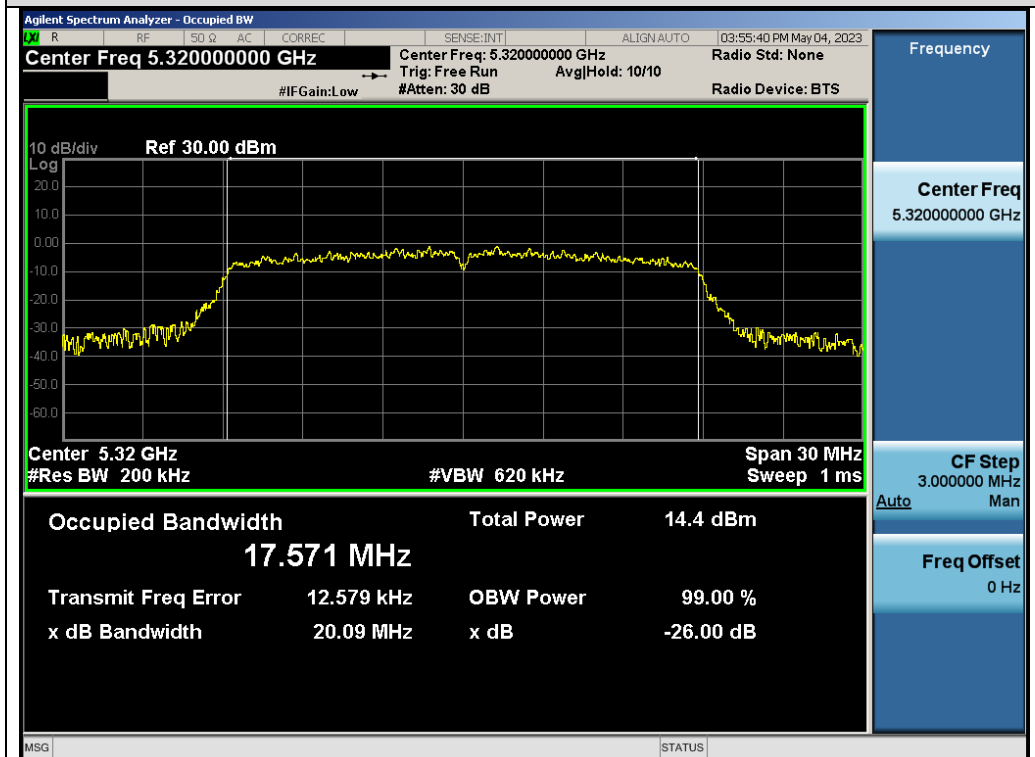

Test\_Graph\_802.11n20\_ANT1\_5320\_MCS0\_OBW

Any report having not been signed by authorized approver, or having been altered without authorization, or having not been stamped by the "Dedicated Testing/Inspection Stamp" is deemed to be invalid. Copying or excerpting portion of, or altering the content of the report is not permitted without the written authorization of AGC. The test results presented in the report apply only to the tested sample. Any objections to report issued by AGC should be submitted to AGC within 15days after the issuance of the test report. Further enquiry of validity or verification of the test report should be addressed to AGC by agc01@agccert.com.

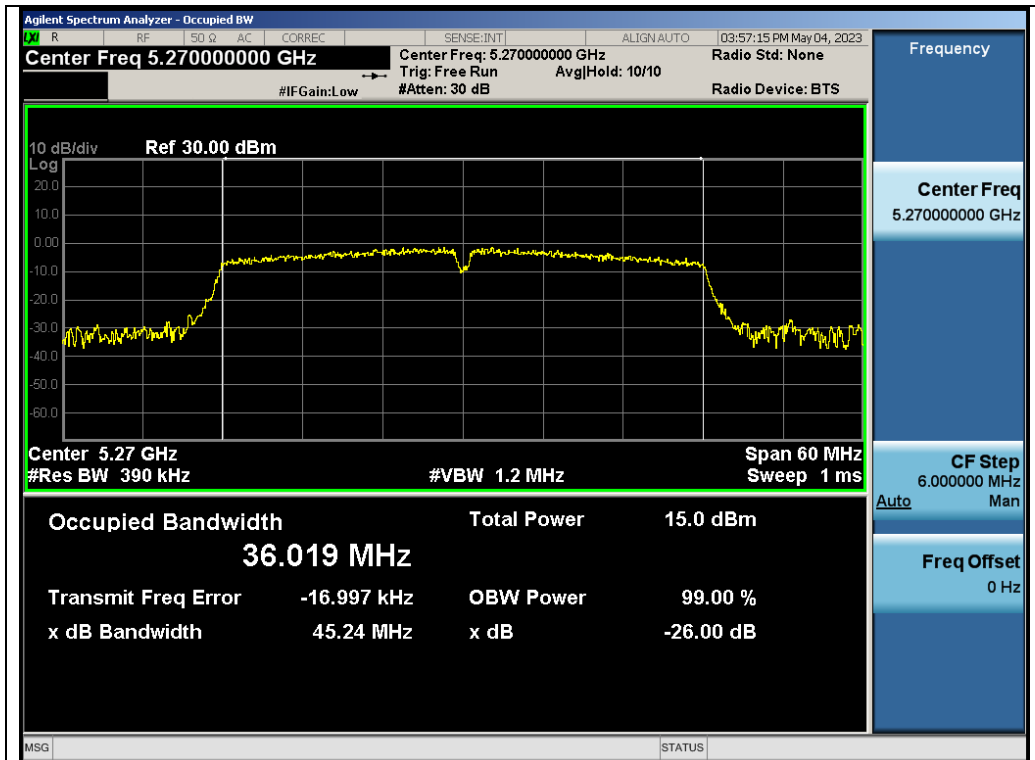

Test\_Graph\_802.11n40\_ANT1\_5270\_MCS0\_OBW

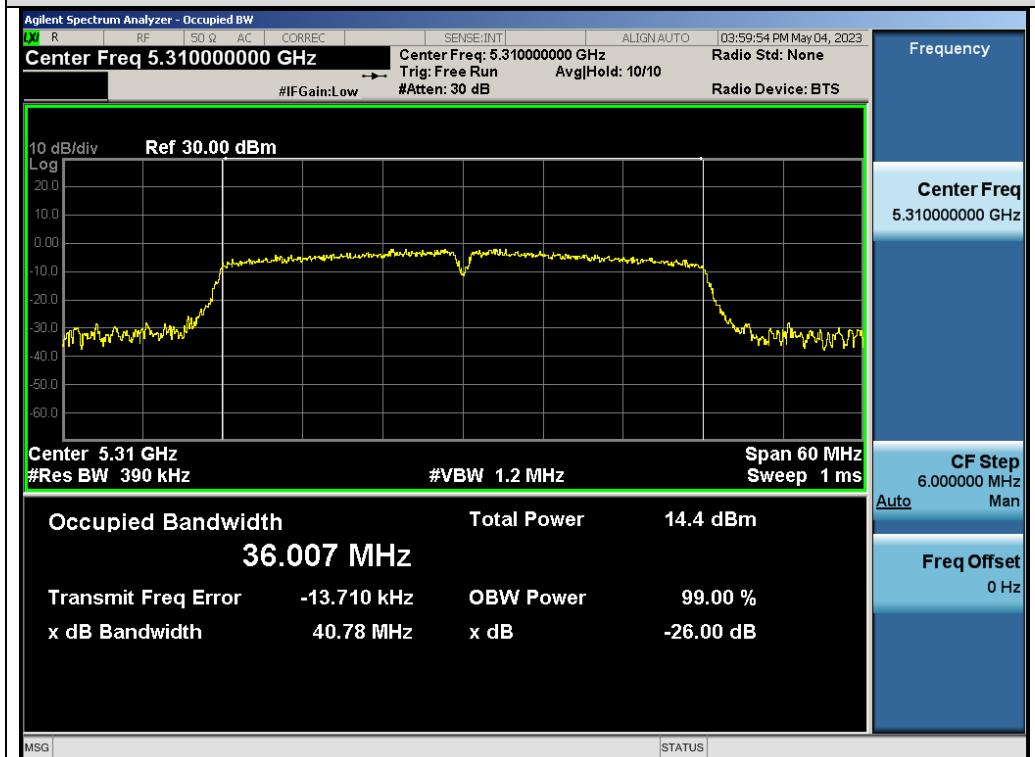

Test\_Graph\_802.11n40\_ANT1\_5310\_MCS0\_OBW

Any report having not been signed by authorized approver, or having been altered without authorization, or having not been stamped by the "Dedicated Testing/Inspection Stamp" is deemed to be invalid. Copying or excerpting portion of, or altering the content of the report is not permitted without the written authorization of AGC. The test results presented in the report apply only to the tested sample. Any objections to report issued by AGC should be submitted to AGC within 15days after the issuance of the test report. Further enquiry of validity or verification of the test report should be addressed to AGC by agc01@agccert.com.

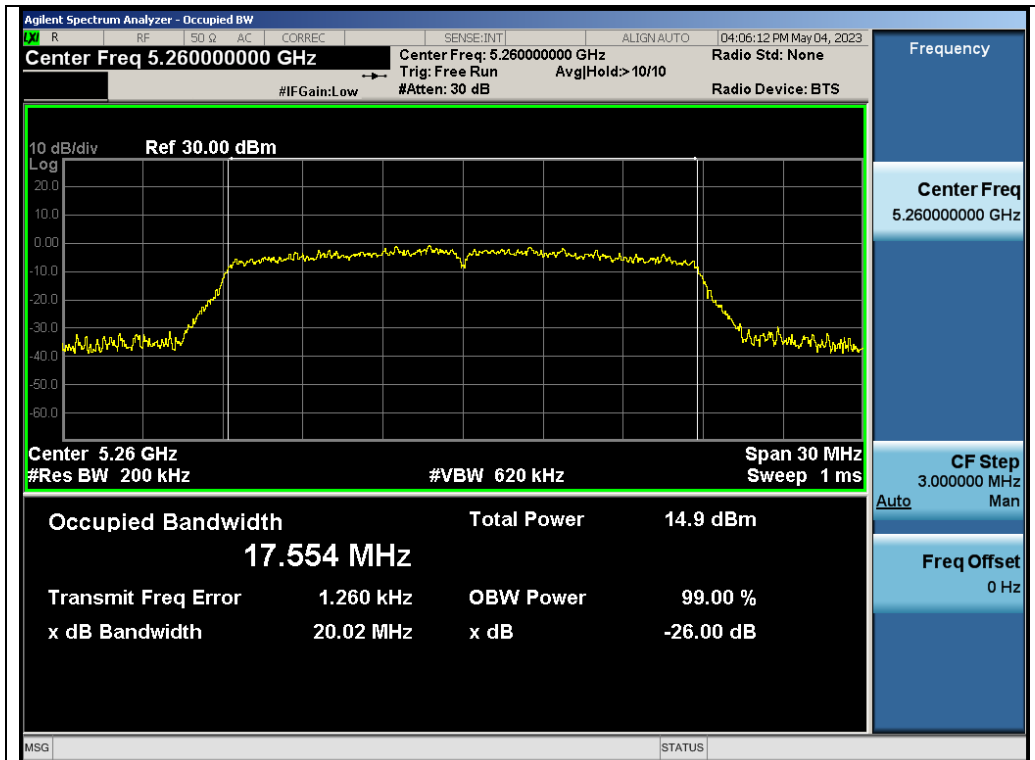

Test\_Graph\_802.11ac20\_ANT1\_5260\_MCS0\_OBW

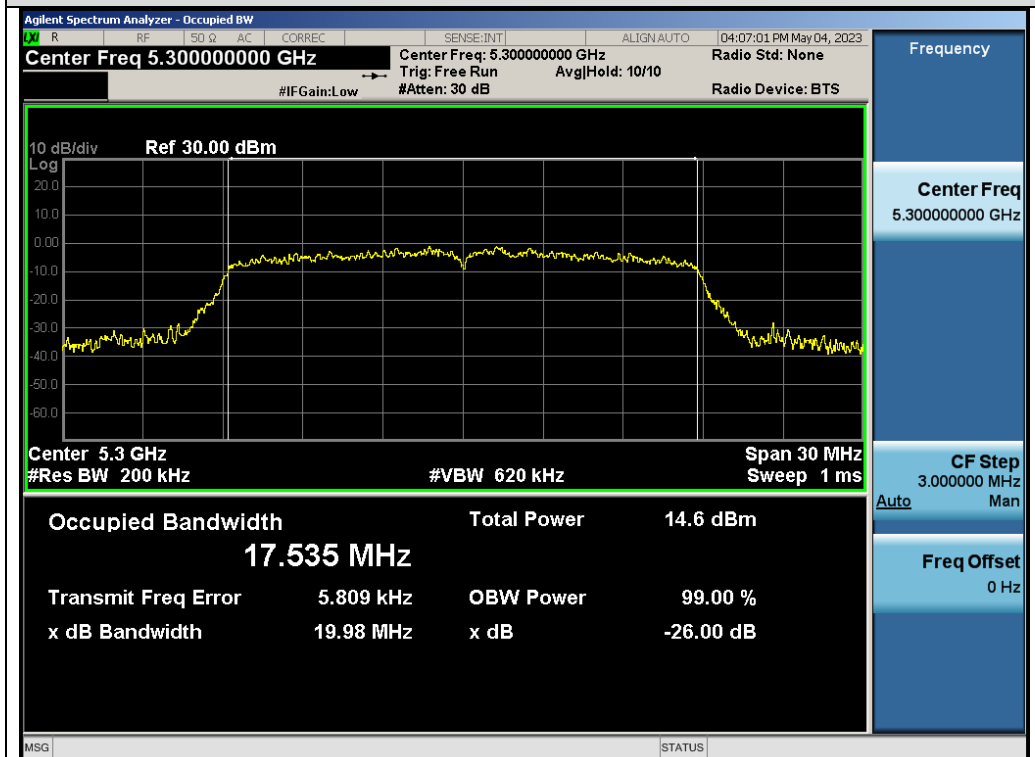

Test\_Graph\_802.11ac20\_ANT1\_5300\_MCS0\_OBW

Any report having not been signed by authorized approver, or having been altered without authorization, or having not been stamped by the "Dedicated Testing/Inspection Stamp" is deemed to be invalid. Copying or excerpting portion of, or altering the content of the report is not permitted without the written authorization of AGC. The test results presented in the report apply only to the tested sample. Any objections to report issued by AGC should be submitted to AGC within 15days after the issuance of the test report. Further enquiry of validity or verification of the test report should be addressed to AGC by agc01@agccert.com.

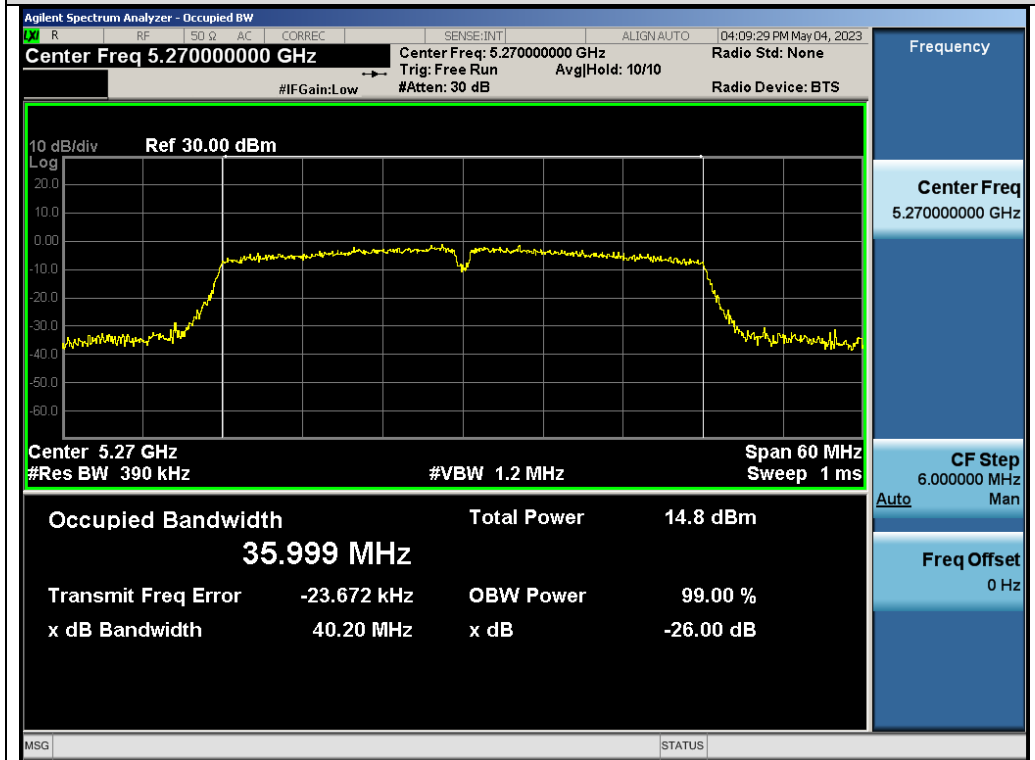
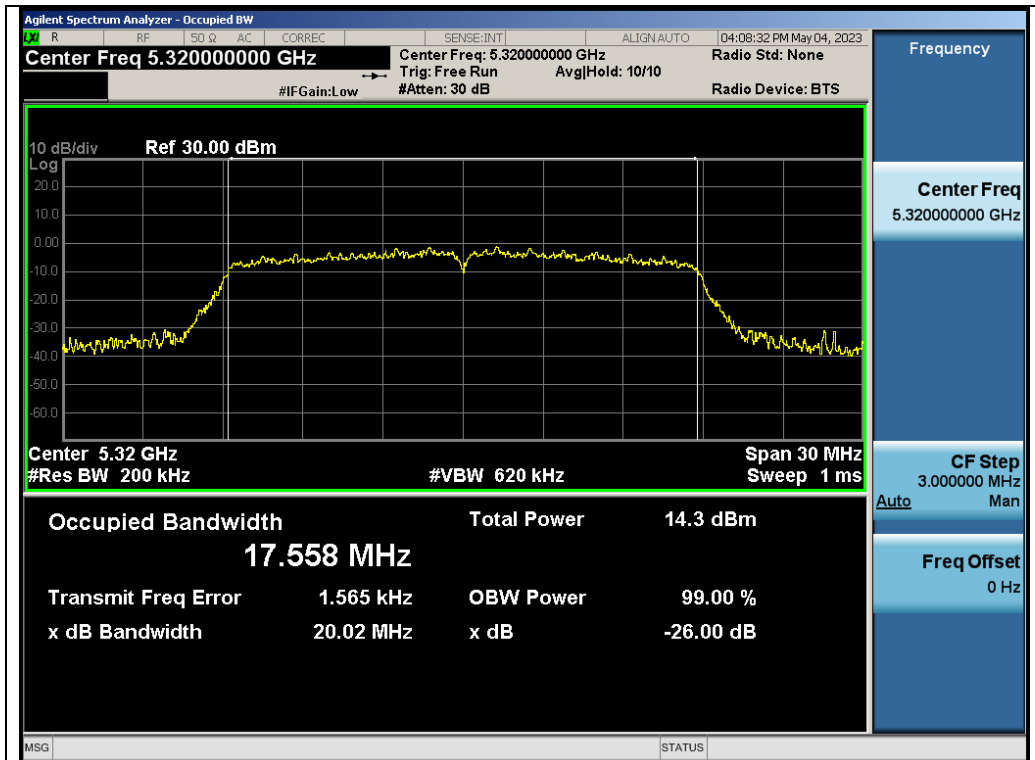

Any report having not been signed by authorized approver, or having been altered without authorization, or having not been stamped by the "Dedicated Testing/Inspection Stamp" is deemed to be invalid. Copying or excerpting portion of, or altering the content of the report is not permitted without the written authorization of AGC. The test results presented in the report apply only to the tested sample. Any objections to report issued by AGC should be submitted to AGC within 15days after the issuance of the test report. Further enquiry of validity or verification of the test report should be addressed to AGC by agc01@agccert.com.

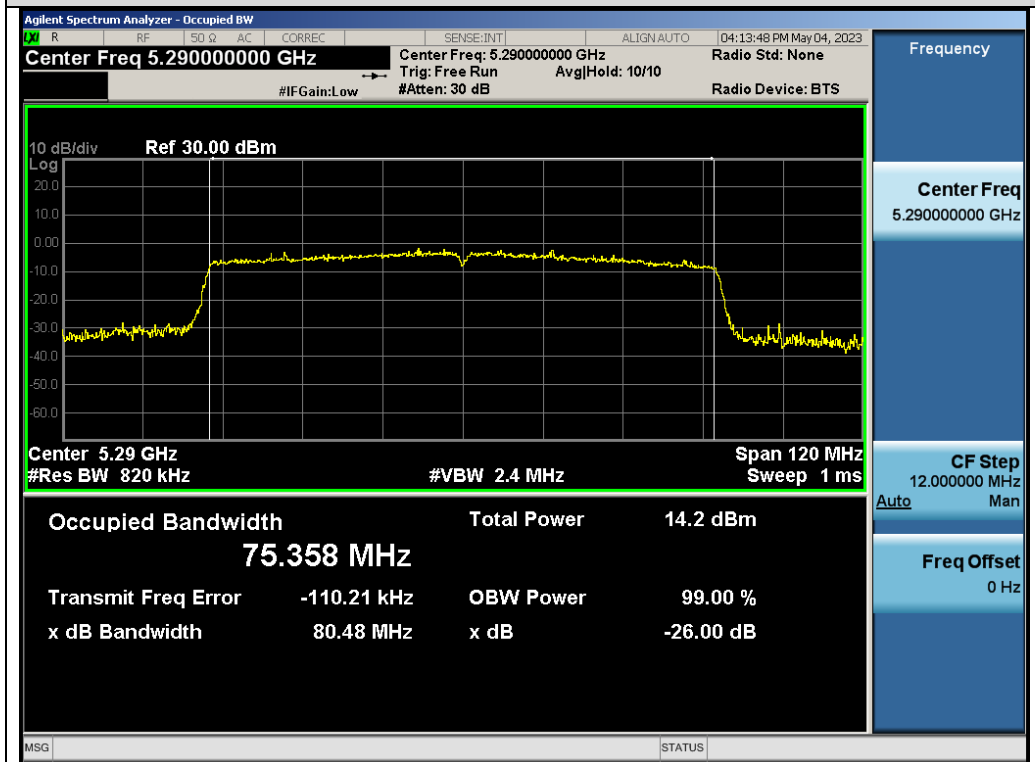
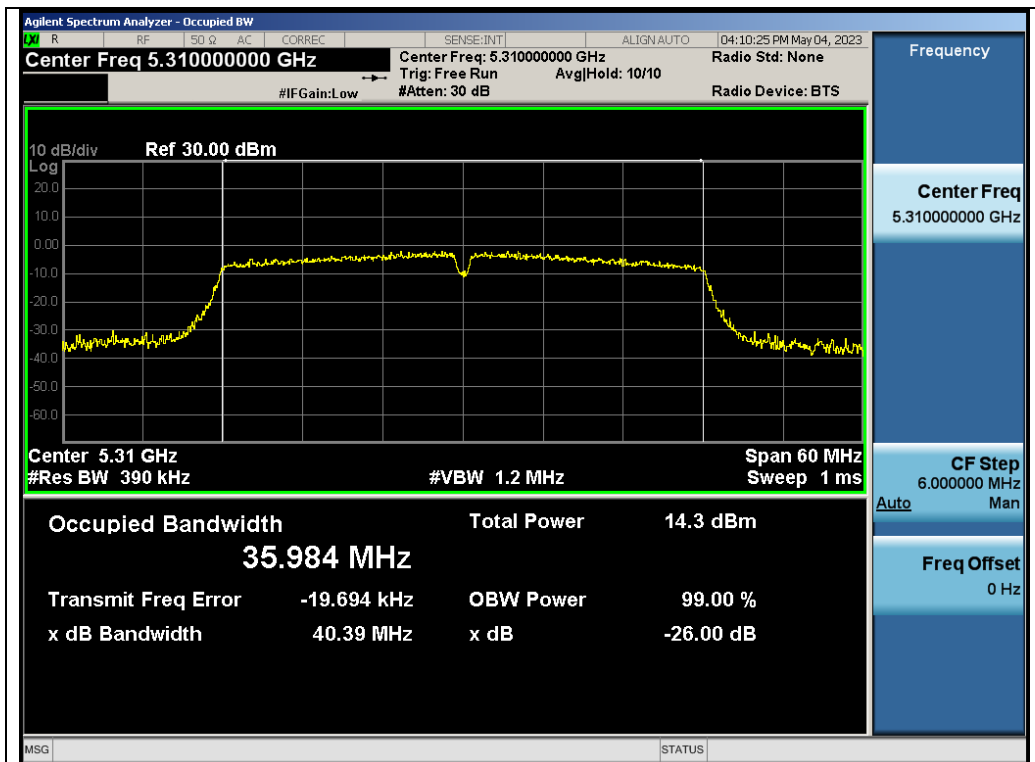

Any report having not been signed by authorized approver, or having been altered without authorization, or having not been stamped by the "Dedicated Testing/Inspection Stamp" is deemed to be invalid. Copying or excerpting portion of, or altering the content of the report is not permitted without the written authorization of AGC. The test results presented in the report apply only to the tested sample. Any objections to report issued by AGC should be submitted to AGC within 15days after the issuance of the test report. Further enquiry of validity or verification of the test report should be addressed to AGC by agc01@agccert.com.

**Test Graphs of Occupied Bandwidth and -26dB Bandwidth for band 5.470-5.725 GHz**

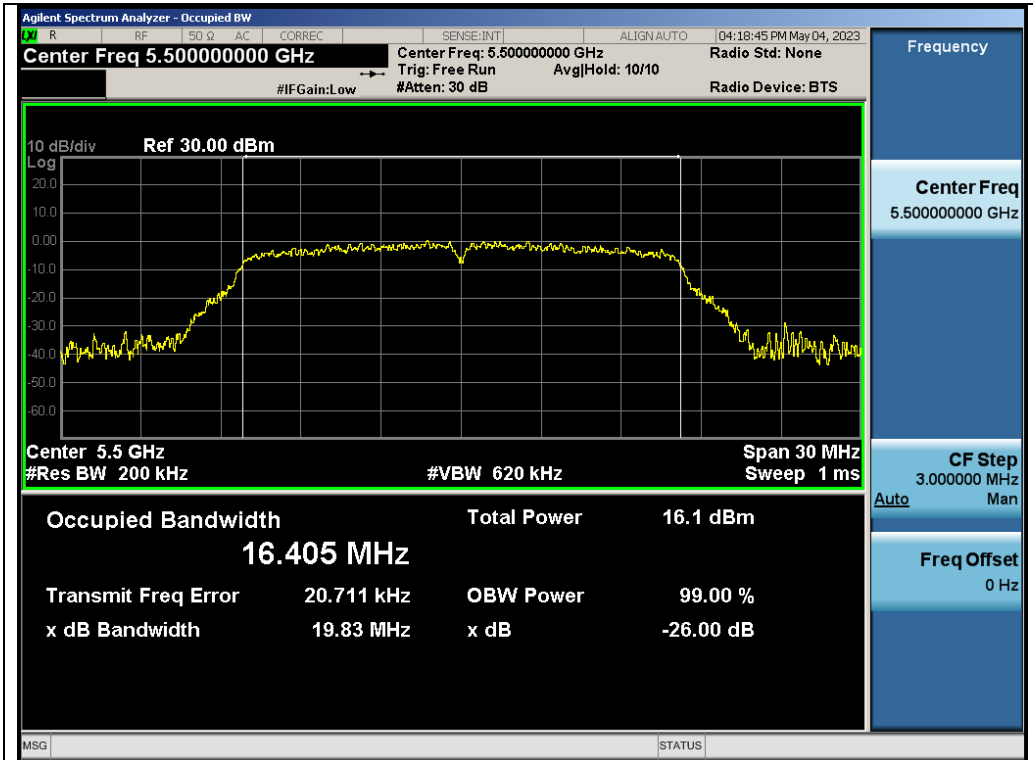

Test\_Graph\_802.11a\_ANT1\_5500\_6Mbps\_OBW

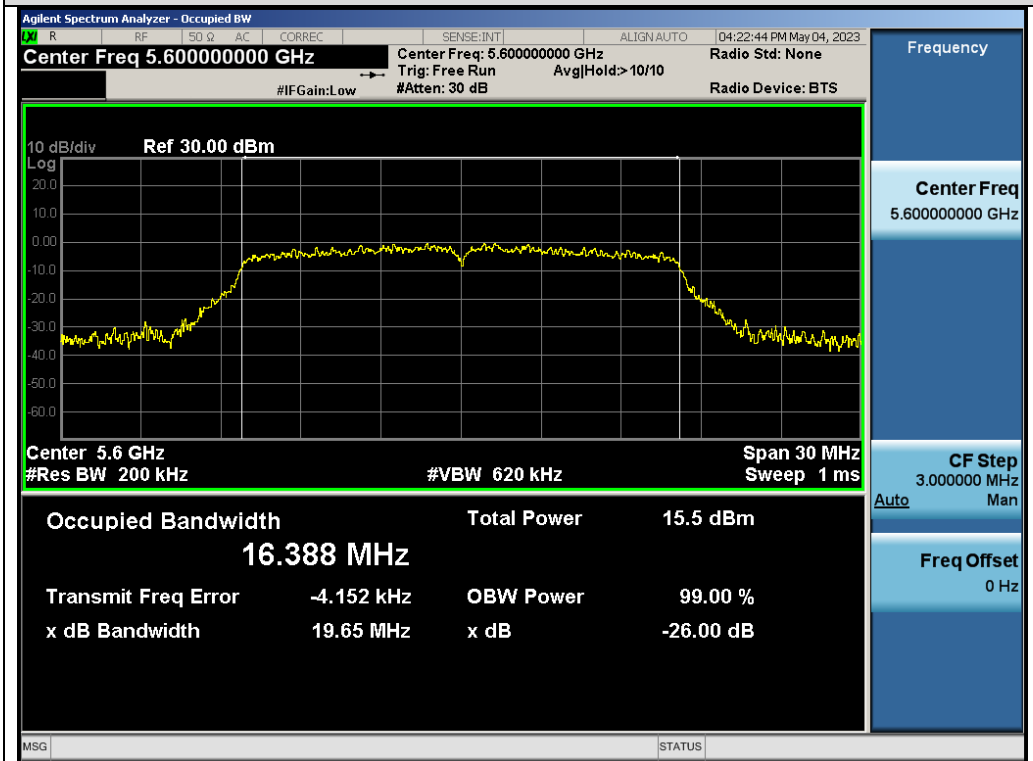

Test\_Graph\_802.11a\_ANT1\_5600\_6Mbps\_OBW

Any report having not been signed by authorized approver, or having been altered without authorization, or having not been stamped by the "Dedicated Testing/Inspection Stamp" is deemed to be invalid. Copying or excerpting portion of, or altering the content of the report is not permitted without the written authorization of AGC. The test results presented in the report apply only to the tested sample. Any objections to report issued by AGC should be submitted to AGC within 15 days after the issuance of the test report. Further enquiry of validity or verification of the test report should be addressed to AGC by agc01@agccert.com.



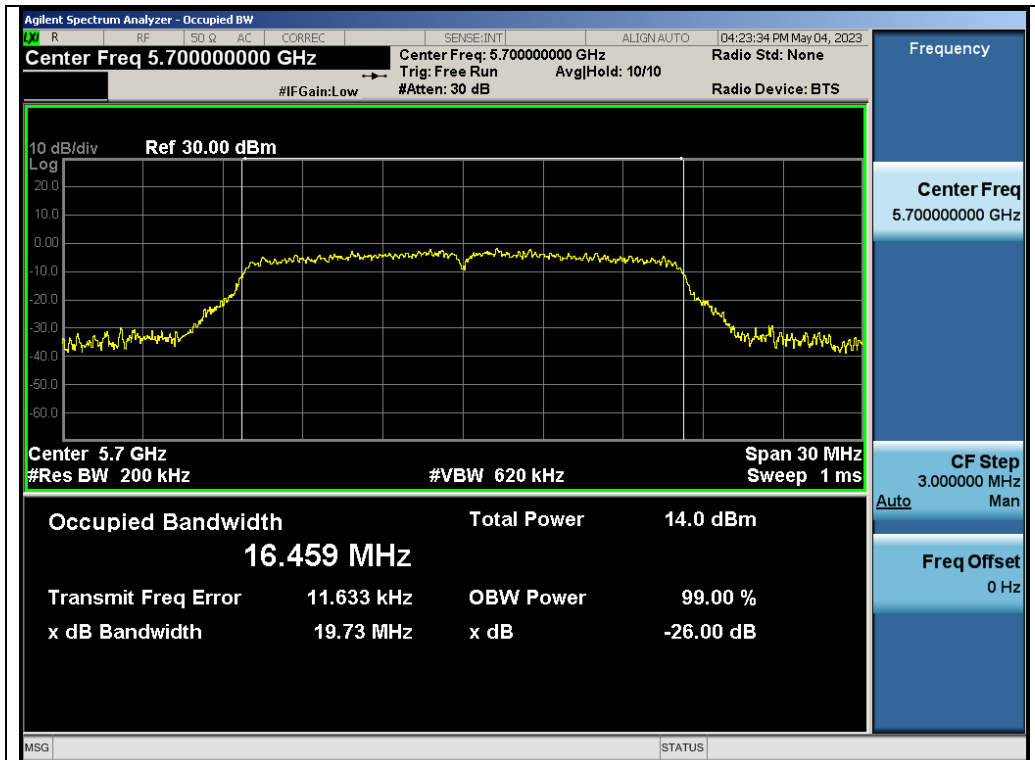

Test\_Graph\_802.11a\_ANT1\_5700\_6Mbps\_OBW

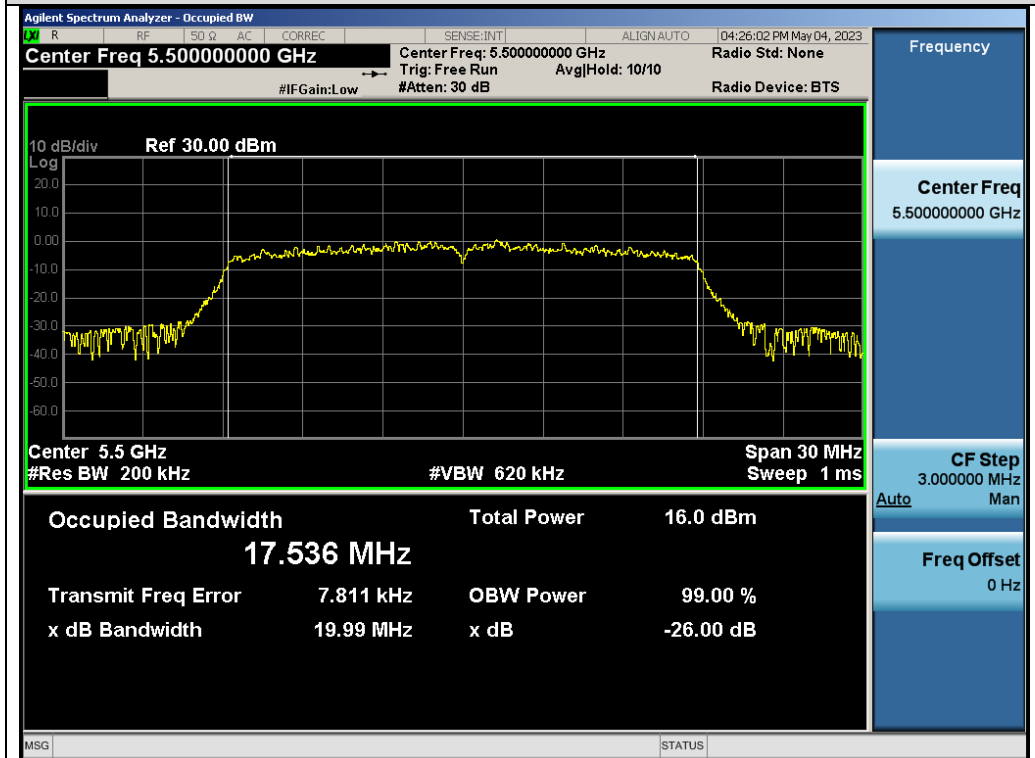

Test\_Graph\_802.11n20\_ANT1\_5500\_MCS0\_OBW

Any report having not been signed by authorized approver, or having been altered without authorization, or having not been stamped by the "Dedicated Testing/Inspection Stamp" is deemed to be invalid. Copying or excerpting portion of, or altering the content of the report is not permitted without the written authorization of AGC. The test results presented in the report apply only to the tested sample. Any objections to report issued by AGC should be submitted to AGC within 15days after the issuance of the test report. Further enquiry of validity or verification of the test report should be addressed to AGC by agc01@agccert.com.



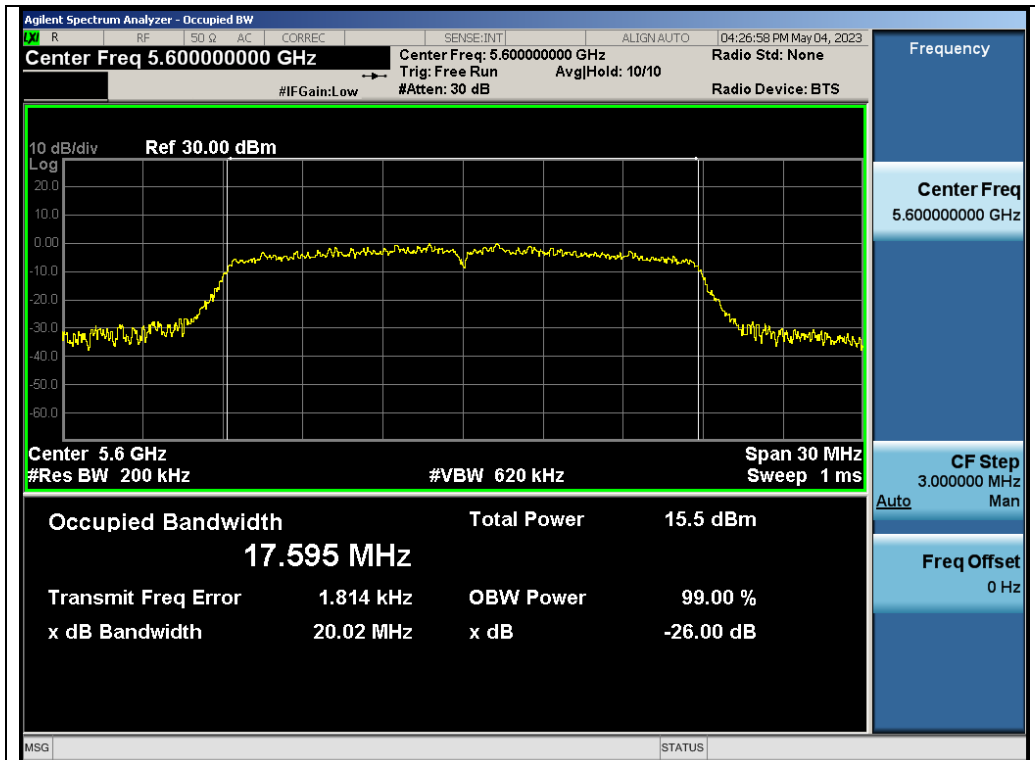

Test\_Graph\_802.11n20\_ANT1\_5600\_MCS0\_OBW

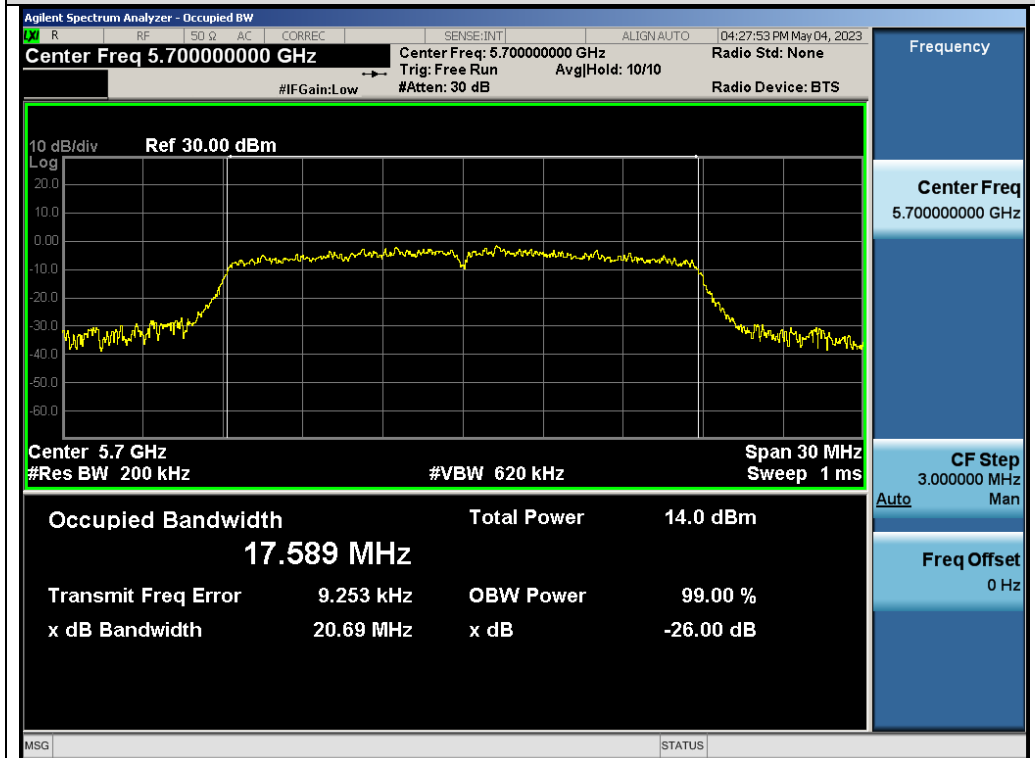

Test\_Graph\_802.11n20\_ANT1\_5700\_MCS0\_OBW

Any report having not been signed by authorized approver, or having been altered without authorization, or having not been stamped by the "Dedicated Testing/Inspection Stamp" is deemed to be invalid. Copying or excerpting portion of, or altering the content of the report is not permitted without the written authorization of AGC. The test results presented in the report apply only to the tested sample. Any objections to report issued by AGC should be submitted to AGC within 15days after the issuance of the test report. Further enquiry of validity or verification of the test report should be addressed to AGC by agc01@agccert.com.

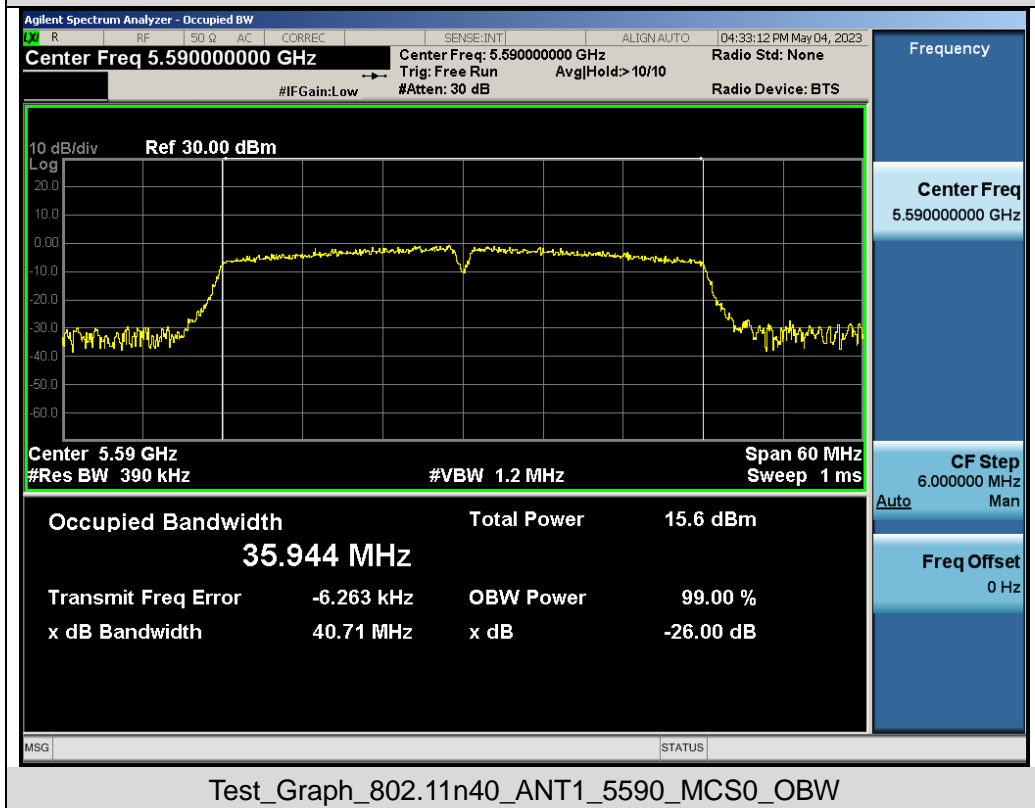
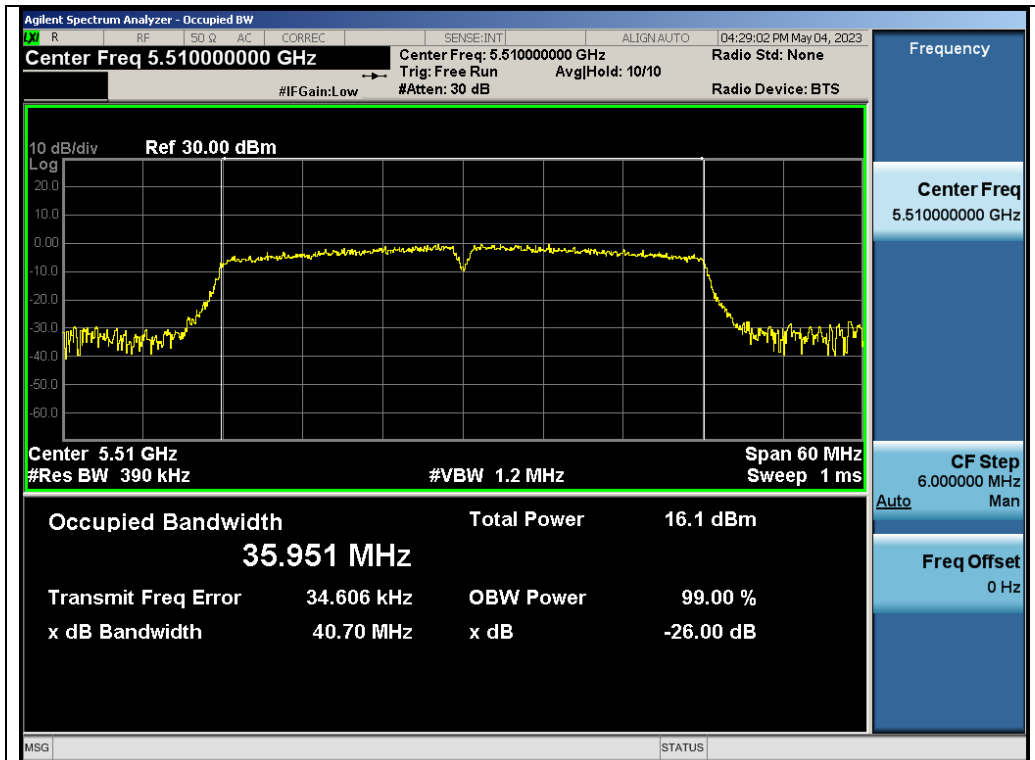

Any report having not been signed by authorized approver, or having been altered without authorization, or having not been stamped by the "Dedicated Testing/Inspection Stamp" is deemed to be invalid. Copying or excerpting portion of, or altering the content of the report is not permitted without the written authorization of AGC. The test results presented in the report apply only to the tested sample. Any objections to report issued by AGC should be submitted to AGC within 15days after the issuance of the test report. Further enquiry of validity or verification of the test report should be addressed to AGC by agc01@agccert.com.

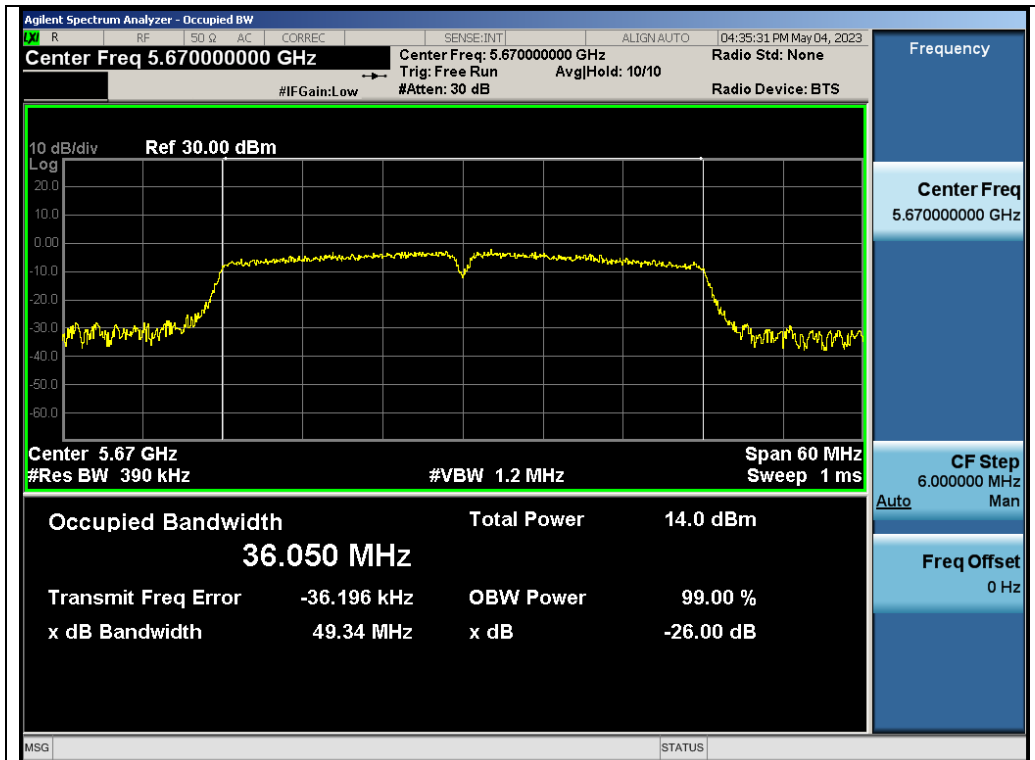

Test\_Graph\_802.11n40\_ANT1\_5670\_MCS0\_OBW

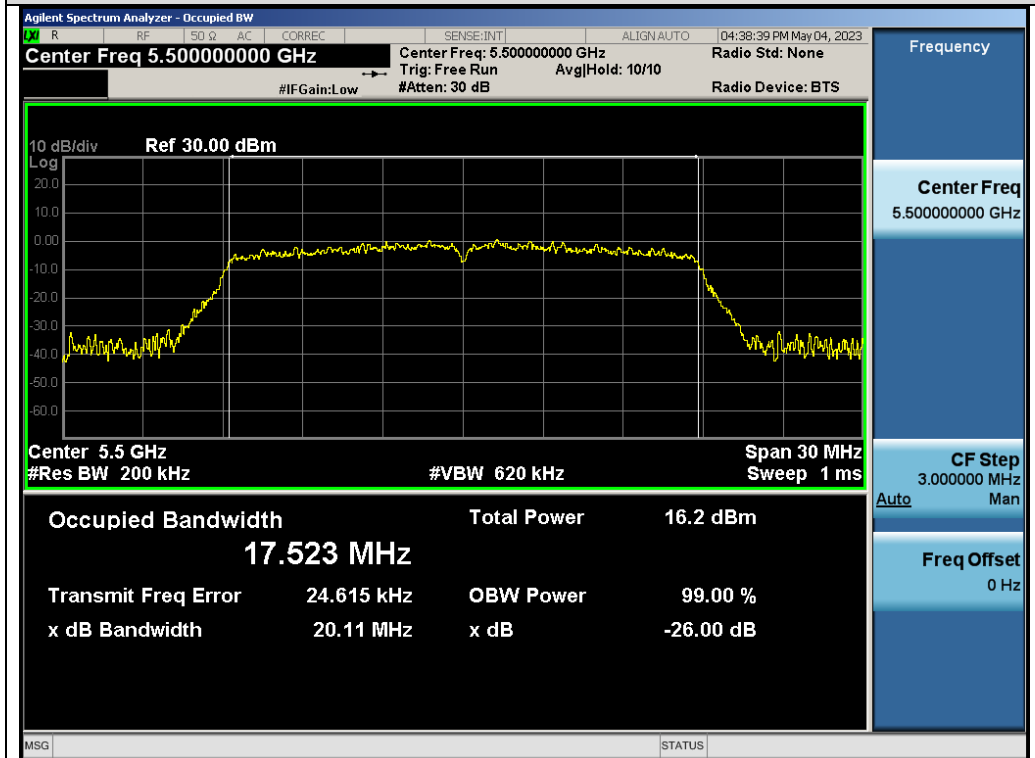

Test\_Graph\_802.11ac20\_ANT1\_5500\_MCS0\_OBW

Any report having not been signed by authorized approver, or having been altered without authorization, or having not been stamped by the "Dedicated Testing/Inspection Stamp" is deemed to be invalid. Copying or excerpting portion of, or altering the content of the report is not permitted without the written authorization of AGC. The test results presented in the report apply only to the tested sample. Any objections to report issued by AGC should be submitted to AGC within 15days after the issuance of the test report. Further enquiry of validity or verification of the test report should be addressed to AGC by agc01@agccert.com.

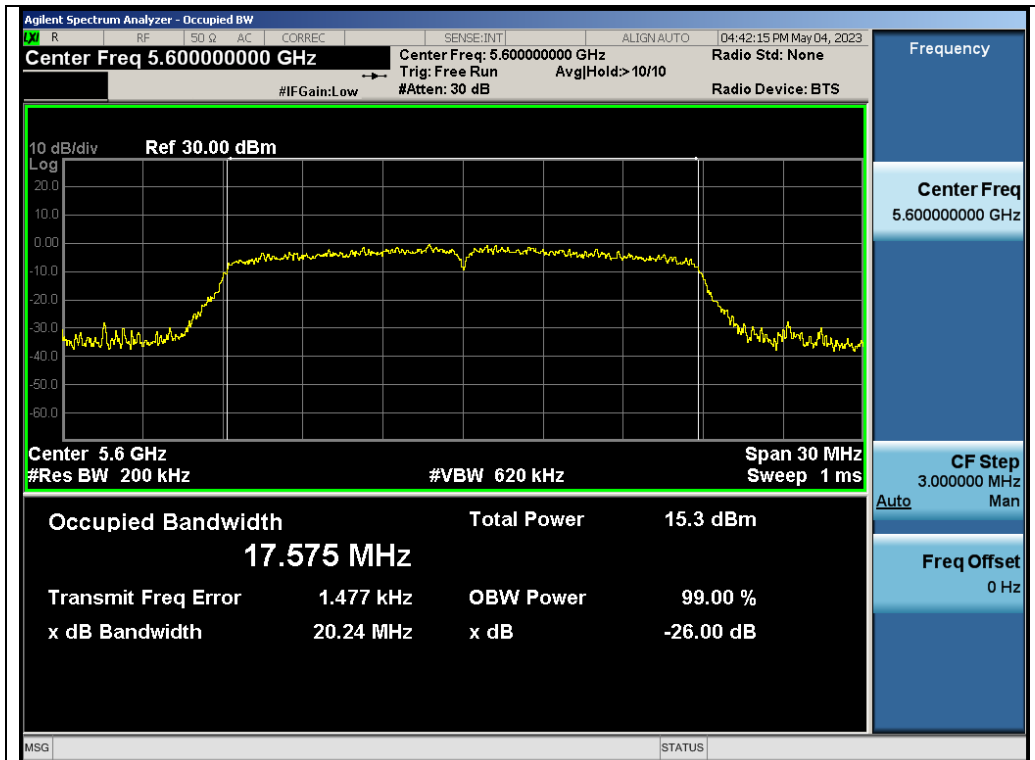

Test\_Graph\_802.11ac20\_ANT1\_5600\_MCS0\_OBW

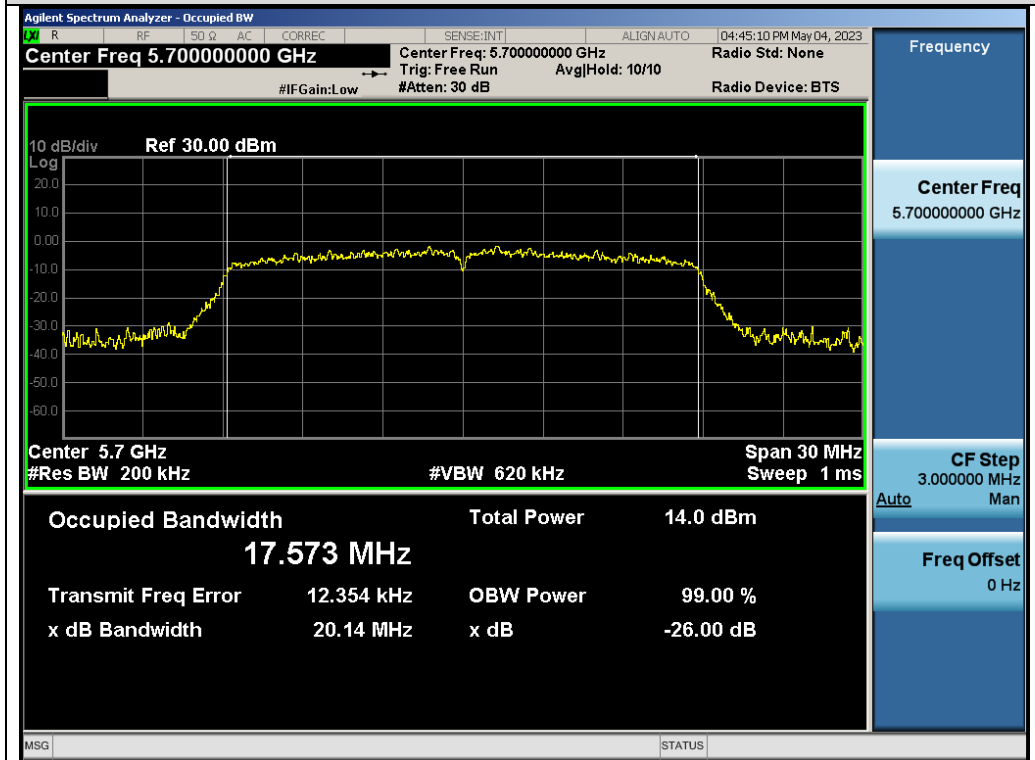

Test\_Graph\_802.11ac20\_ANT1\_5700\_MCS0\_OBW

Any report having not been signed by authorized approver, or having been altered without authorization, or having not been stamped by the "Dedicated Testing/Inspection Stamp" is deemed to be invalid. Copying or excerpting portion of, or altering the content of the report is not permitted without the written authorization of AGC. The test results presented in the report apply only to the tested sample. Any objections to report issued by AGC should be submitted to AGC within 15 days after the issuance of the test report. Further enquiry of validity or verification of the test report should be addressed to AGC by agc01@agccert.com.

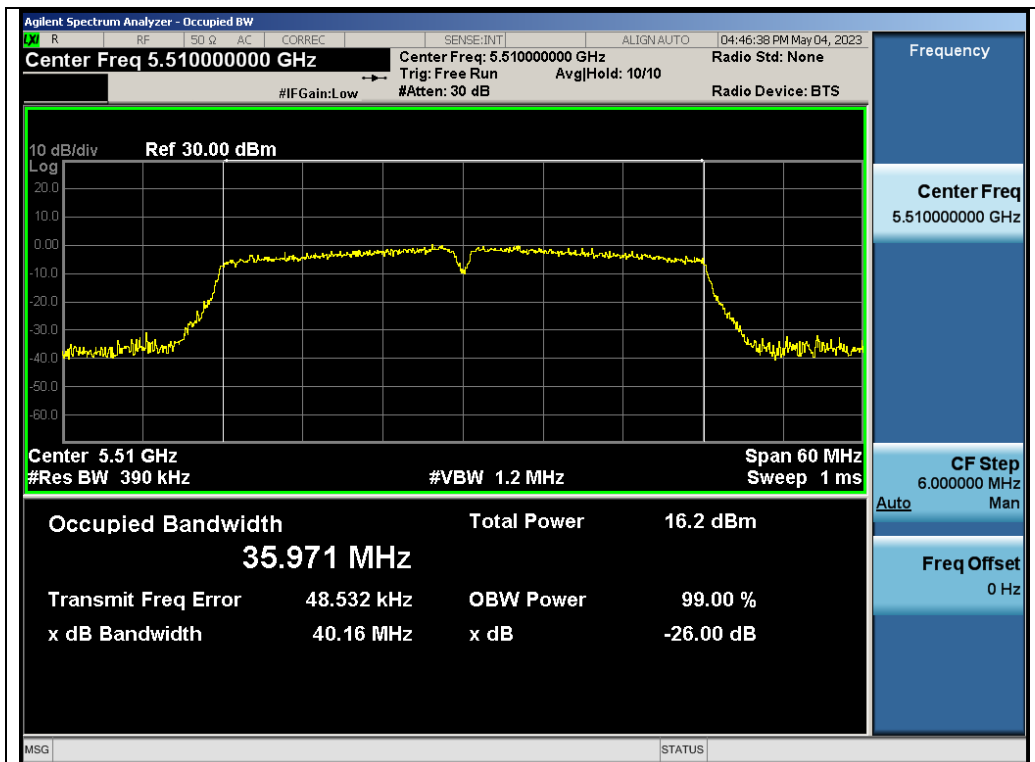

Test\_Graph\_802.11ac40\_ANT1\_5510\_MCS0\_OBW

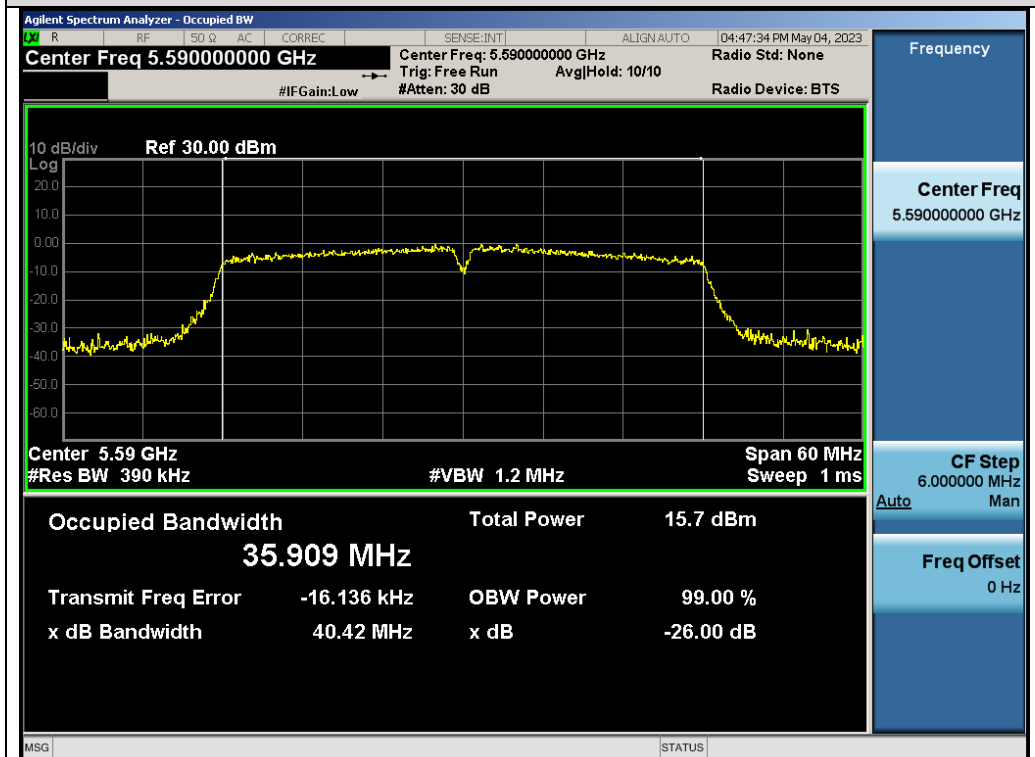

Test\_Graph\_802.11ac40\_ANT1\_5590\_MCS0\_OBW

Any report having not been signed by authorized approver, or having been altered without authorization, or having not been stamped by the "Dedicated Testing/Inspection Stamp" is deemed to be invalid. Copying or excerpting portion of, or altering the content of the report is not permitted without the written authorization of AGC. The test results presented in the report apply only to the tested sample. Any objections to report issued by AGC should be submitted to AGC within 15days after the issuance of the test report. Further enquiry of validity or verification of the test report should be addressed to AGC by agc01@agccert.com.

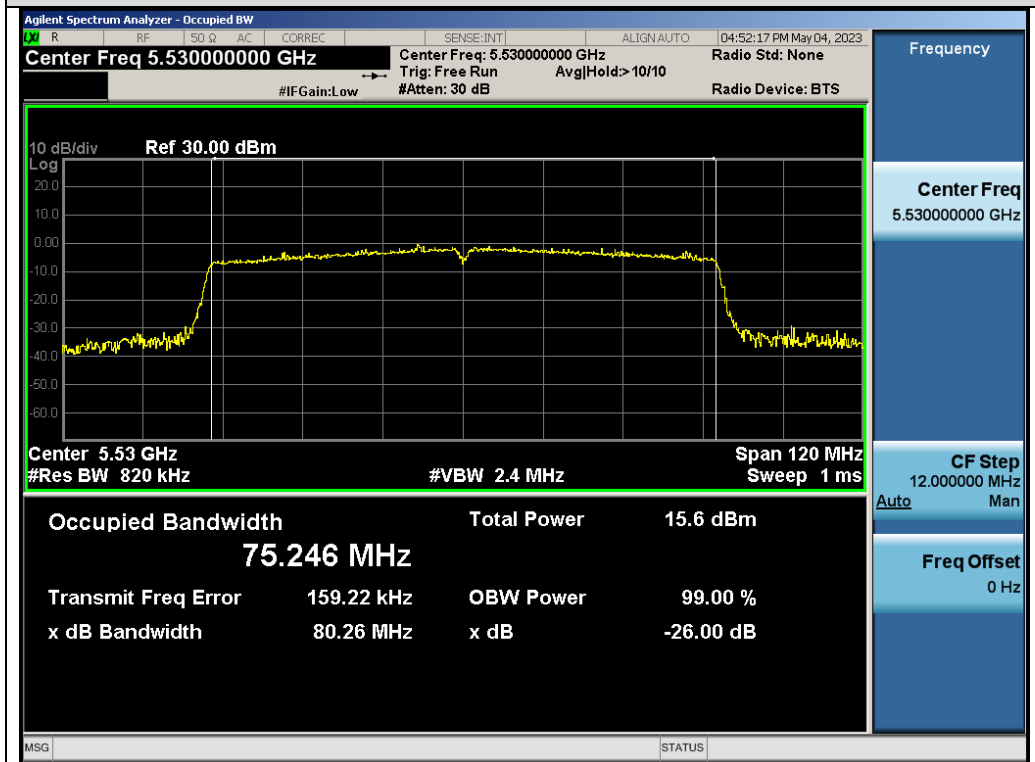
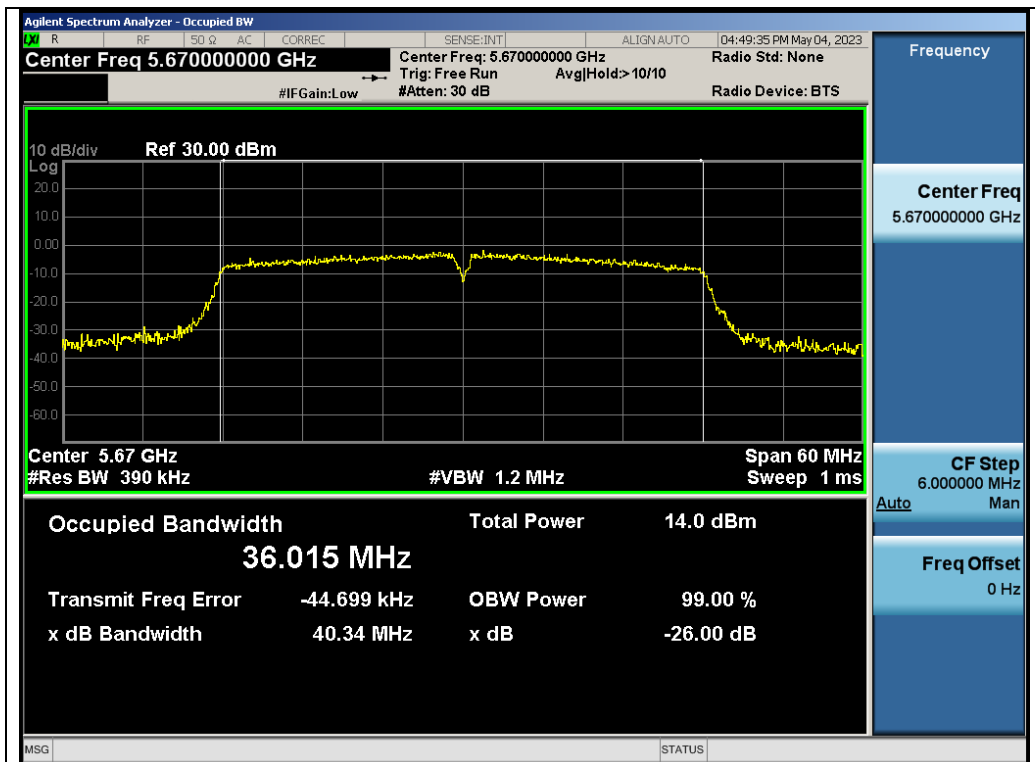

Any report having not been signed by authorized approver, or having been altered without authorization, or having not been stamped by the "Dedicated Testing/Inspection Stamp" is deemed to be invalid. Copying or excerpting portion of, or altering the content of the report is not permitted without the written authorization of AGC. The test results presented in the report apply only to the tested sample. Any objections to report issued by AGC should be submitted to AGC within 15 days after the issuance of the test report. Further enquiry of validity or verification of the test report should be addressed to AGC by agc01@agccert.com.

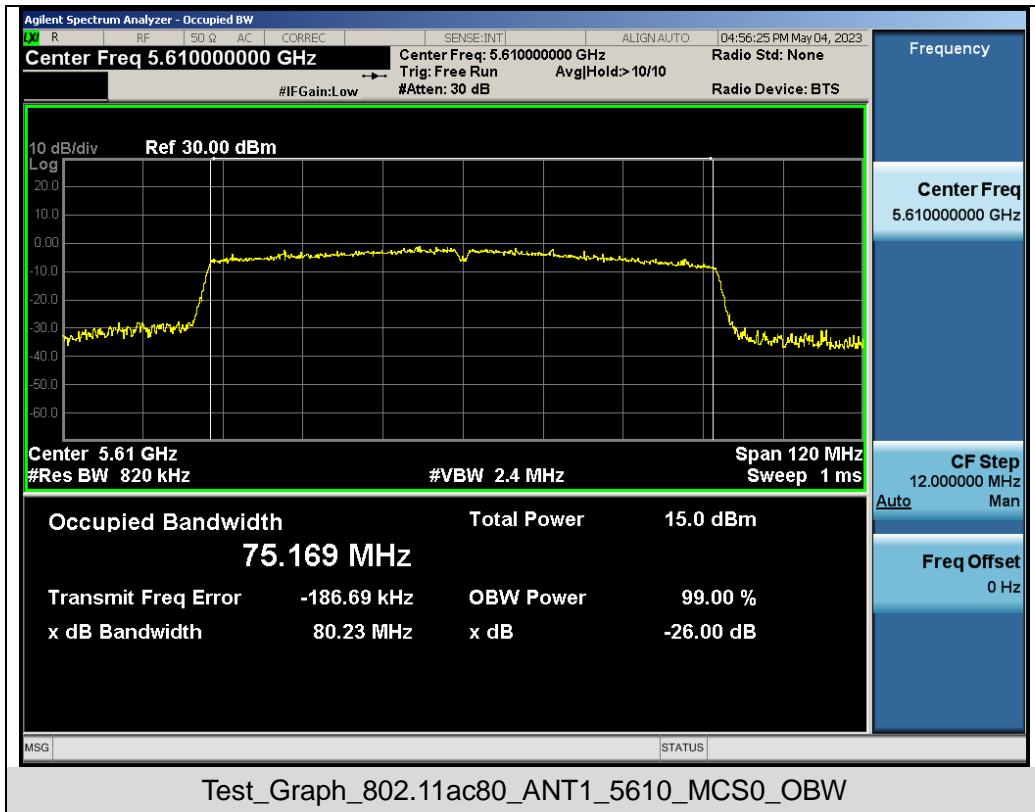

Any report having not been signed by authorized approver, or having been altered without authorization, or having not been stamped by the "Dedicated Testing/Inspection Stamp" is deemed to be invalid. Copying or excerpting portion of, or altering the content of the report is not permitted without the written authorization of AGC. The test results presented in the report apply only to the tested sample. Any objections to report issued by AGC should be submitted to AGC within 15days after the issuance of the test report. Further enquiry of validity or verification of the test report should be addressed to AGC by agc01@agccert.com.

Attestation of Global Compliance(Shenzhen)Co., Ltd  
 Attestation of Global Compliance(Shenzhen)Std & Tech Co., Ltd  
 Tel: +86-755 2523 4088 E-mail: agc@agccert.com Web: http://www.agccert.com/

**Test Graphs of Occupied Bandwidth and -26dB Bandwidth for band 5.745-5.825 GHz**

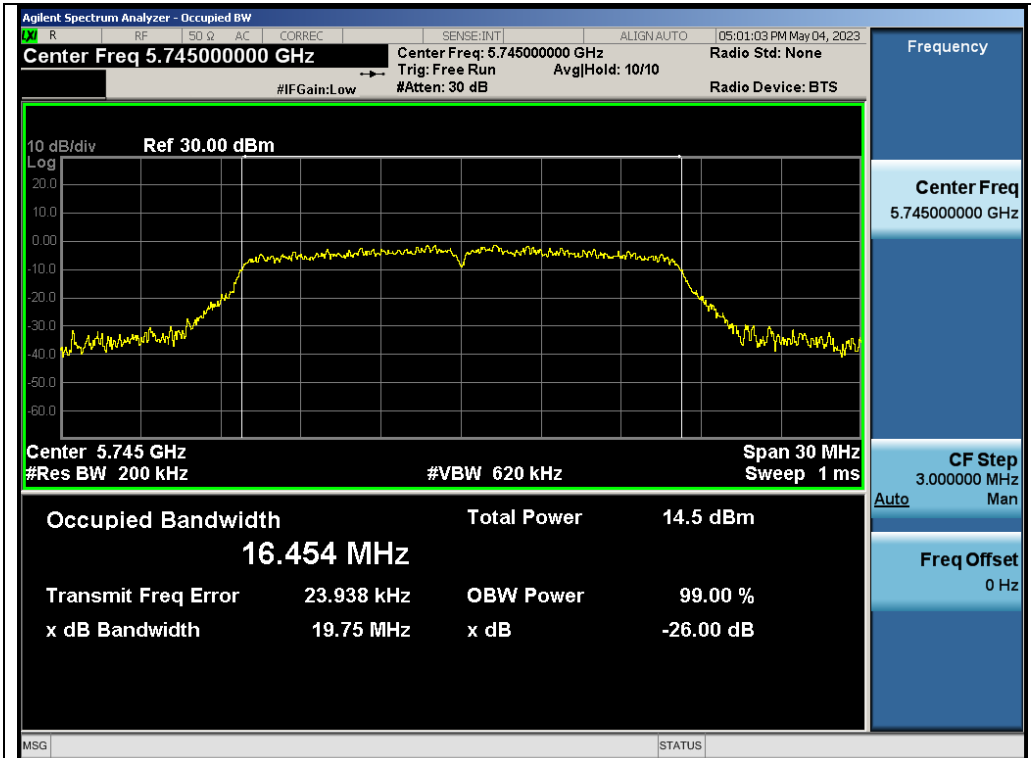

Test\_Graph\_802.11a\_ANT1\_5745\_6Mbps\_OBW

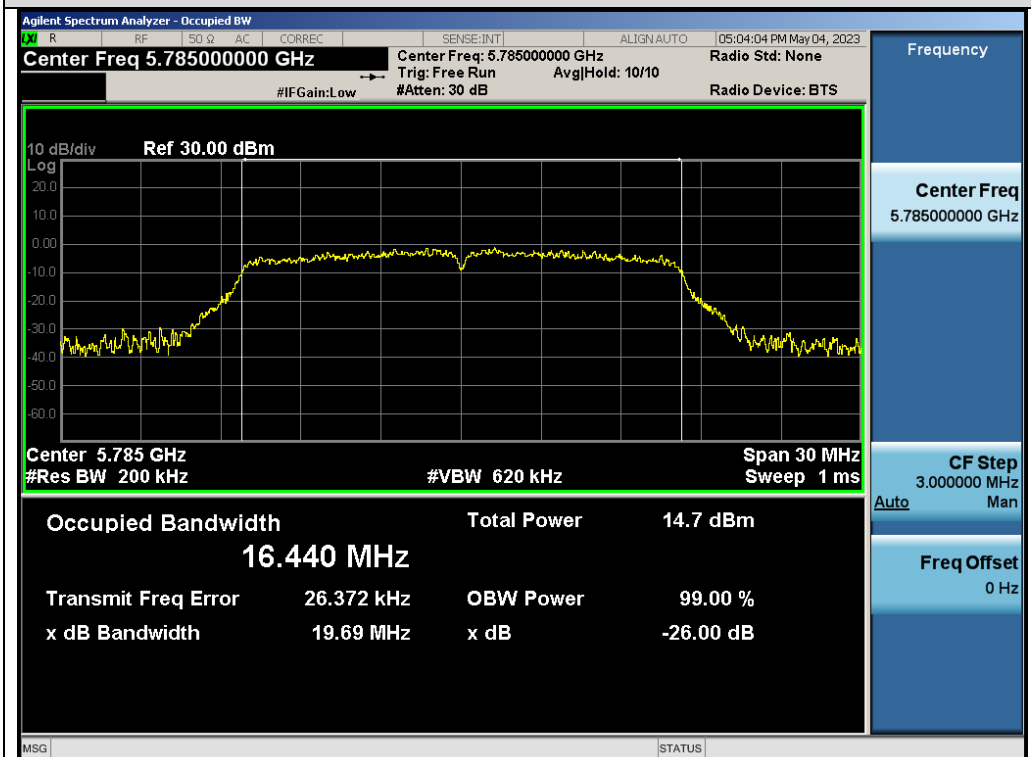

Test\_Graph\_802.11a\_ANT1\_5785\_6Mbps\_OBW

Any report having not been signed by authorized approver, or having been altered without authorization, or having not been stamped by the "Dedicated Testing/Inspection Stamp" is deemed to be invalid. Copying or excerpting portion of, or altering the content of the report is not permitted without the written authorization of AGC. The test results presented in the report apply only to the tested sample. Any objections to report issued by AGC should be submitted to AGC within 15days after the issuance of the test report. Further enquiry of validity or verification of the test report should be addressed to AGC by agc01@agccert.com.



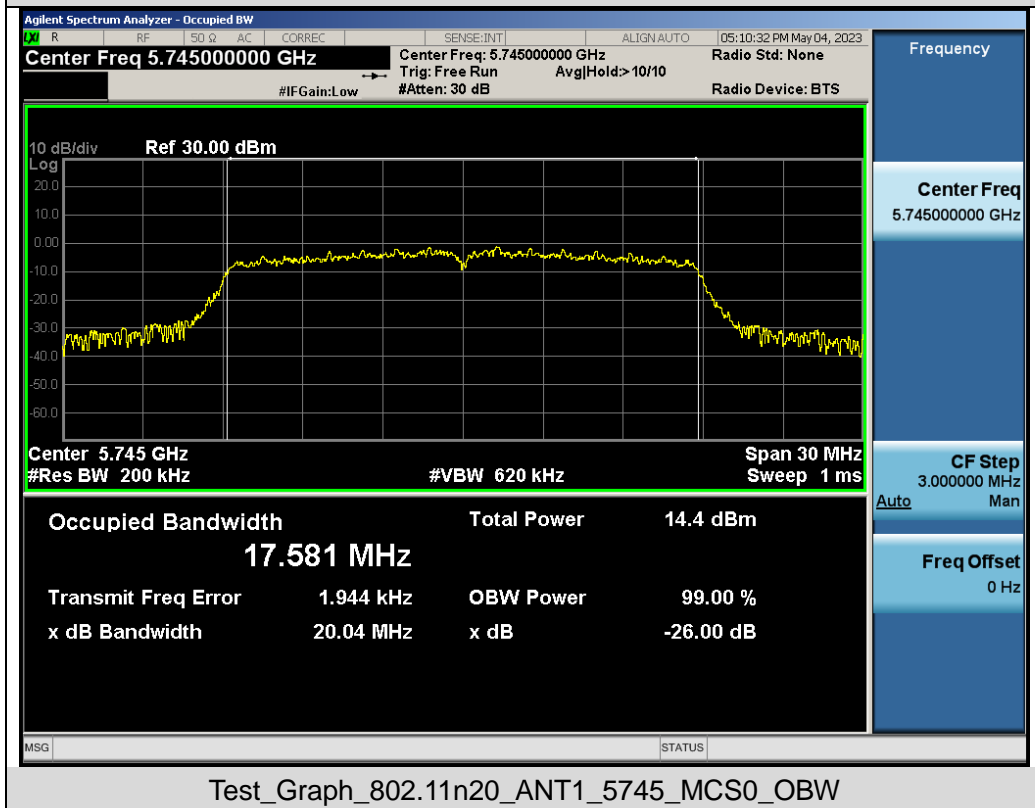
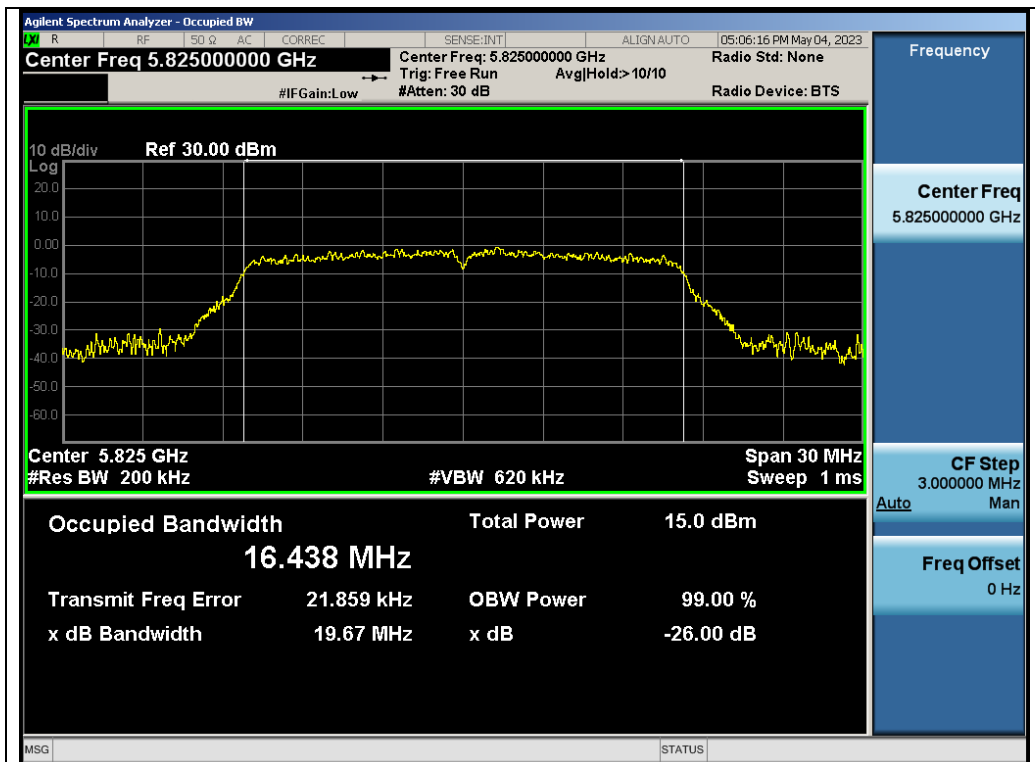

Any report having not been signed by authorized approver, or having been altered without authorization, or having not been stamped by the "Dedicated Testing/Inspection Stamp" is deemed to be invalid. Copying or excerpting portion of, or altering the content of the report is not permitted without the written authorization of AGC. The test results presented in the report apply only to the tested sample. Any objections to report issued by AGC should be submitted to AGC within 15days after the issuance of the test report. Further enquiry of validity or verification of the test report should be addressed to AGC by agc01@agccert.com.

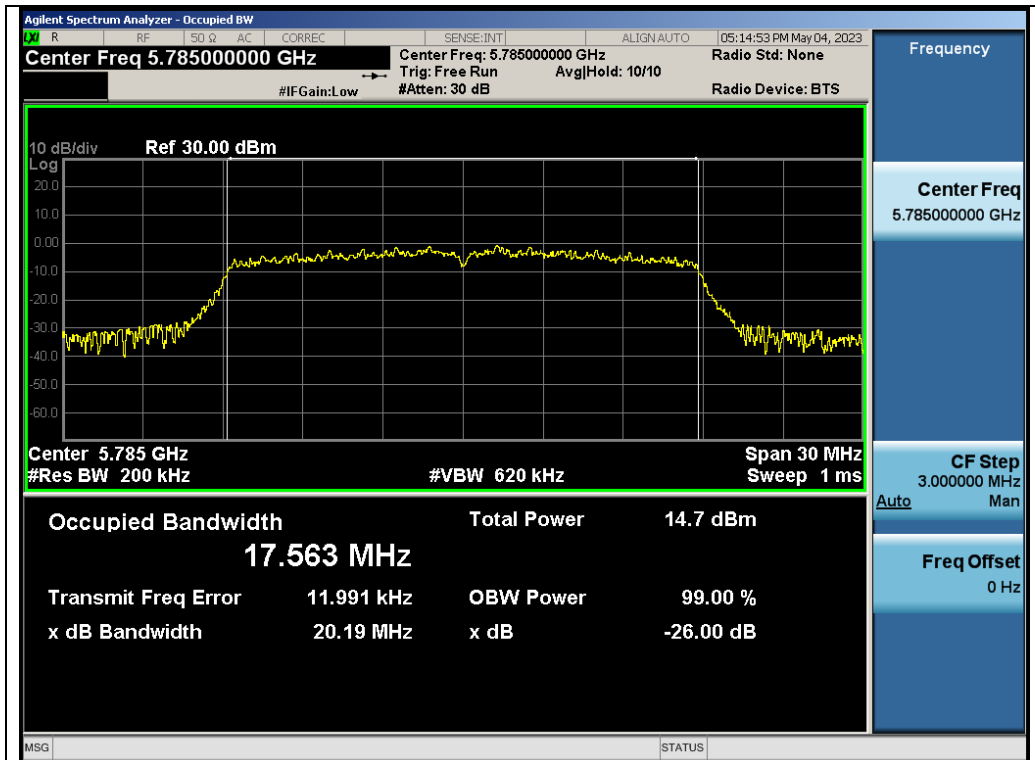

Test\_Graph\_802.11n20\_ANT1\_5785\_MCS0\_OBW

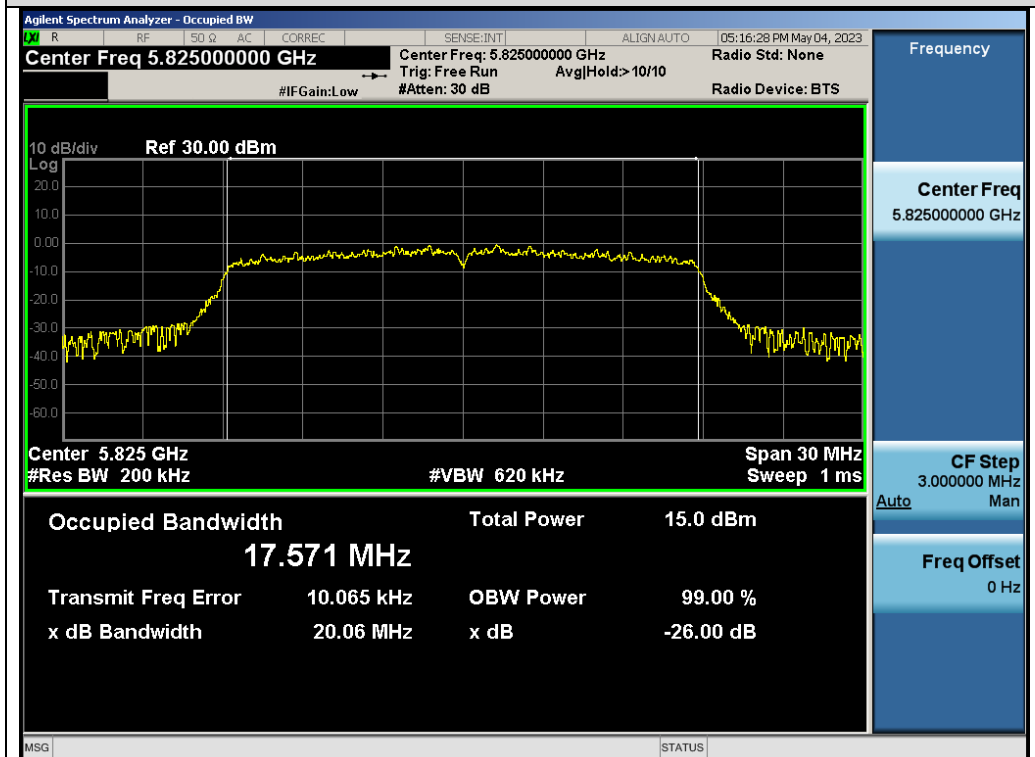

Test\_Graph\_802.11n20\_ANT1\_5825\_MCS0\_OBW

Any report having not been signed by authorized approver, or having been altered without authorization, or having not been stamped by the "Dedicated Testing/Inspection Stamp" is deemed to be invalid. Copying or excerpting portion of, or altering the content of the report is not permitted without the written authorization of AGC. The test results presented in the report apply only to the tested sample. Any objections to report issued by AGC should be submitted to AGC within 15days after the issuance of the test report. Further enquiry of validity or verification of the test report should be addressed to AGC by agc01@agccert.com.

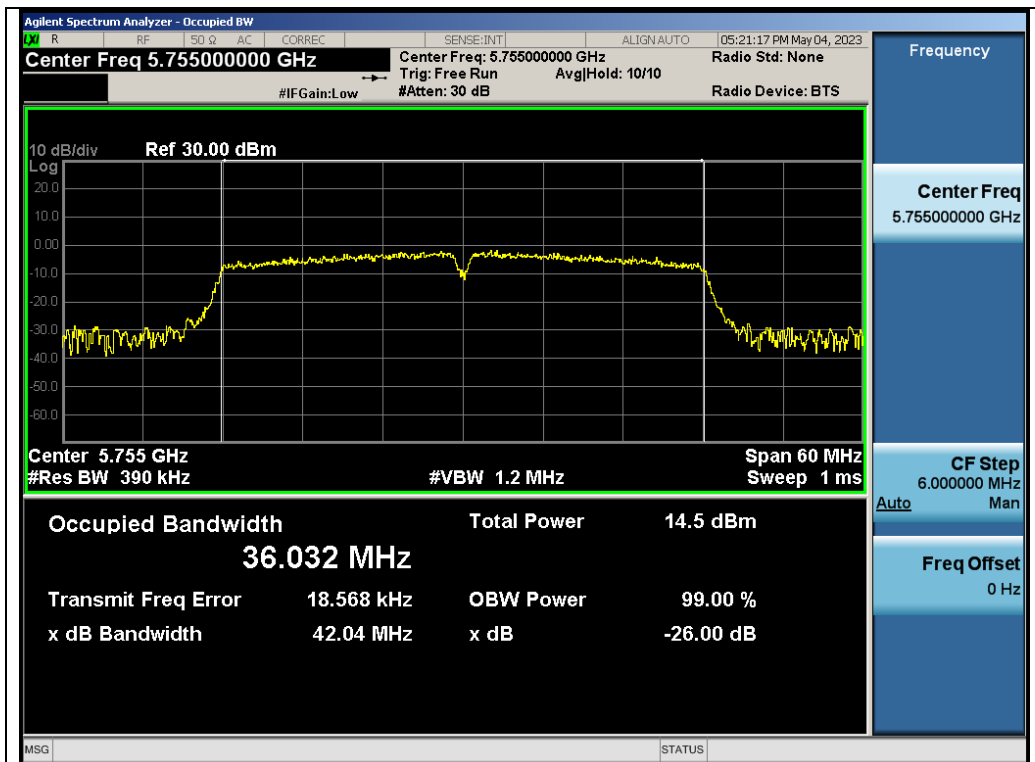

Test\_Graph\_802.11n40\_ANT1\_5755\_MCS0\_OBW

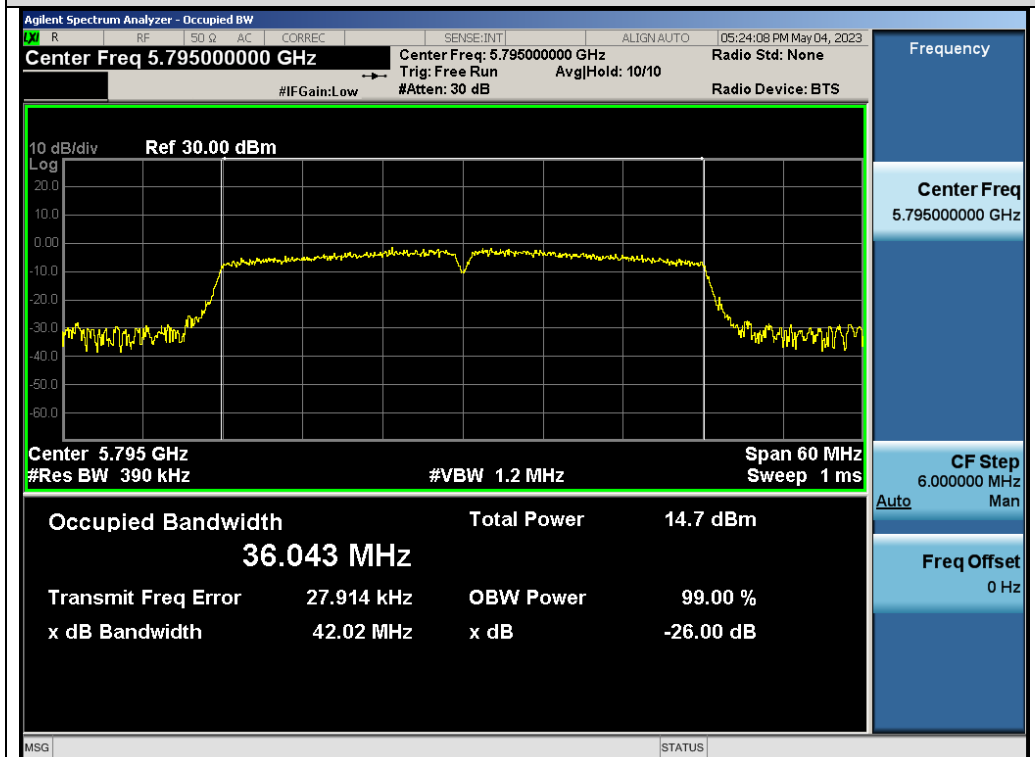

Test\_Graph\_802.11n40\_ANT1\_5795\_MCS0\_OBW

Any report having not been signed by authorized approver, or having been altered without authorization, or having not been stamped by the "Dedicated Testing/Inspection Stamp" is deemed to be invalid. Copying or excerpting portion of, or altering the content of the report is not permitted without the written authorization of AGC. The test results presented in the report apply only to the tested sample. Any objections to report issued by AGC should be submitted to AGC within 15days after the issuance of the test report. Further enquiry of validity or verification of the test report should be addressed to AGC by agc01@agccert.com.

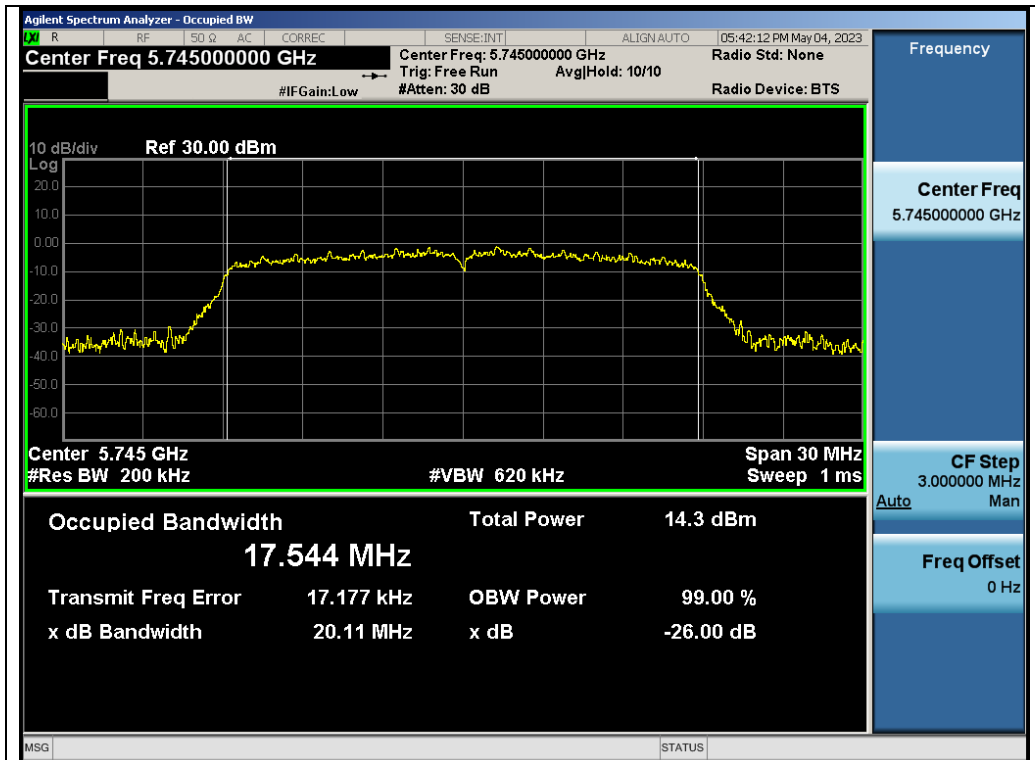

Test\_Graph\_802.11ac20\_ANT1\_5745\_MCS0\_OBW

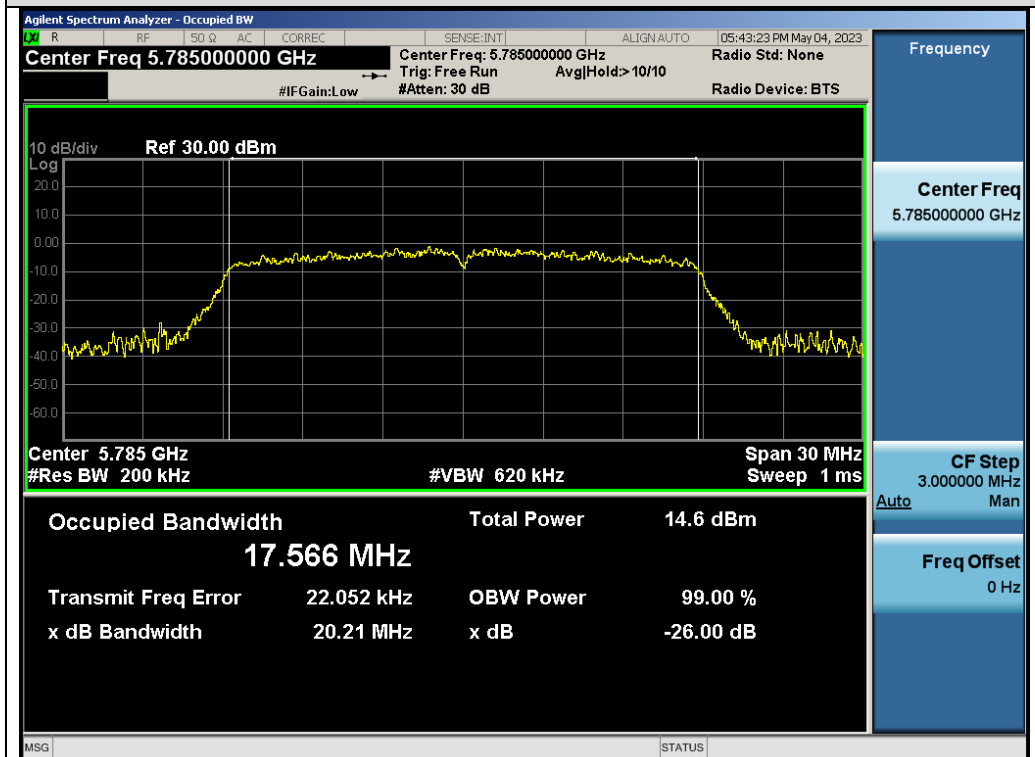

Test\_Graph\_802.11ac20\_ANT1\_5785\_MCS0\_OBW

Any report having not been signed by authorized approver, or having been altered without authorization, or having not been stamped by the "Dedicated Testing/Inspection Stamp" is deemed to be invalid. Copying or excerpting portion of, or altering the content of the report is not permitted without the written authorization of AGC. The test results presented in the report apply only to the tested sample. Any objections to report issued by AGC should be submitted to AGC within 15days after the issuance of the test report. Further enquiry of validity or verification of the test report should be addressed to AGC by agc01@agccert.com.

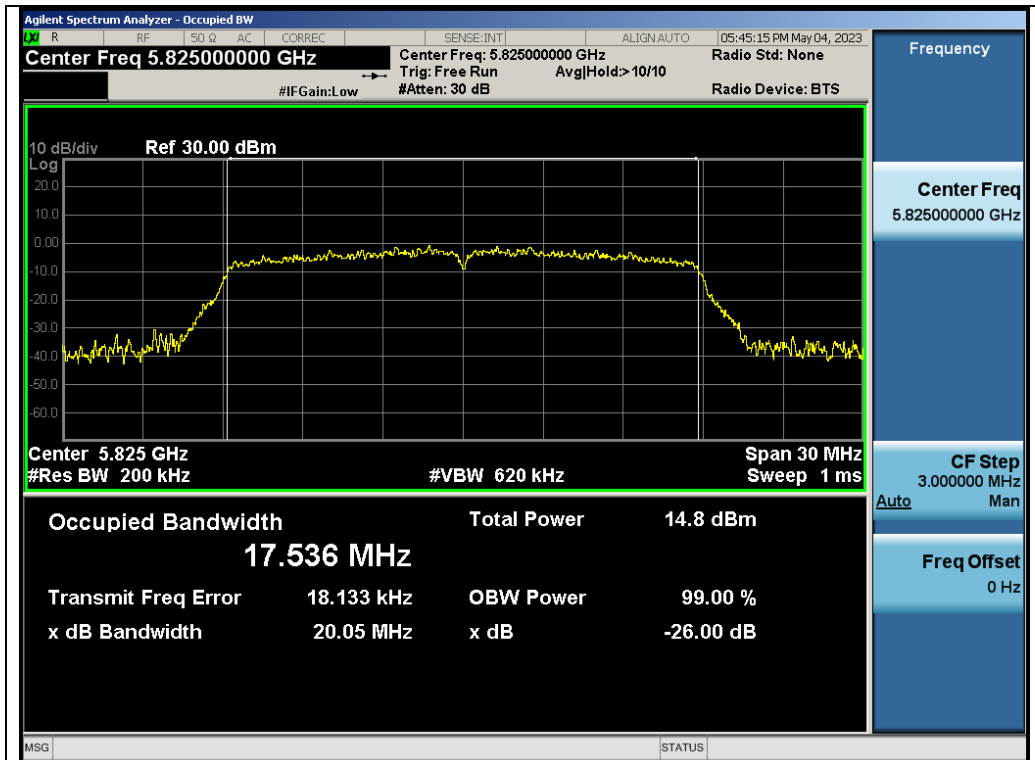

Test\_Graph\_802.11ac20\_ANT1\_5825\_MCS9\_OBW

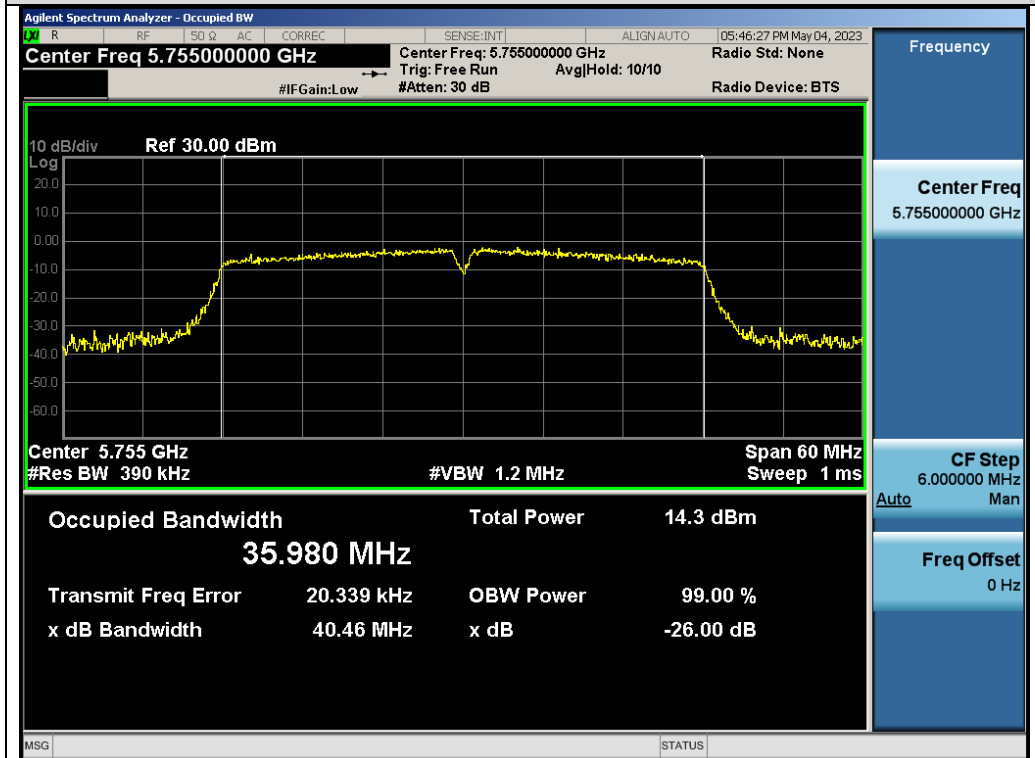

Test\_Graph\_802.11ac40\_ANT1\_5755\_MCS9\_OBW

Any report having not been signed by authorized approver, or having been altered without authorization, or having not been stamped by the "Dedicated Testing/Inspection Stamp" is deemed to be invalid. Copying or excerpting portion of, or altering the content of the report is not permitted without the written authorization of AGC. The test results presented in the report apply only to the tested sample. Any objections to report issued by AGC should be submitted to AGC within 15 days after the issuance of the test report. Further enquiry of validity or verification of the test report should be addressed to AGC by agc01@agccert.com.

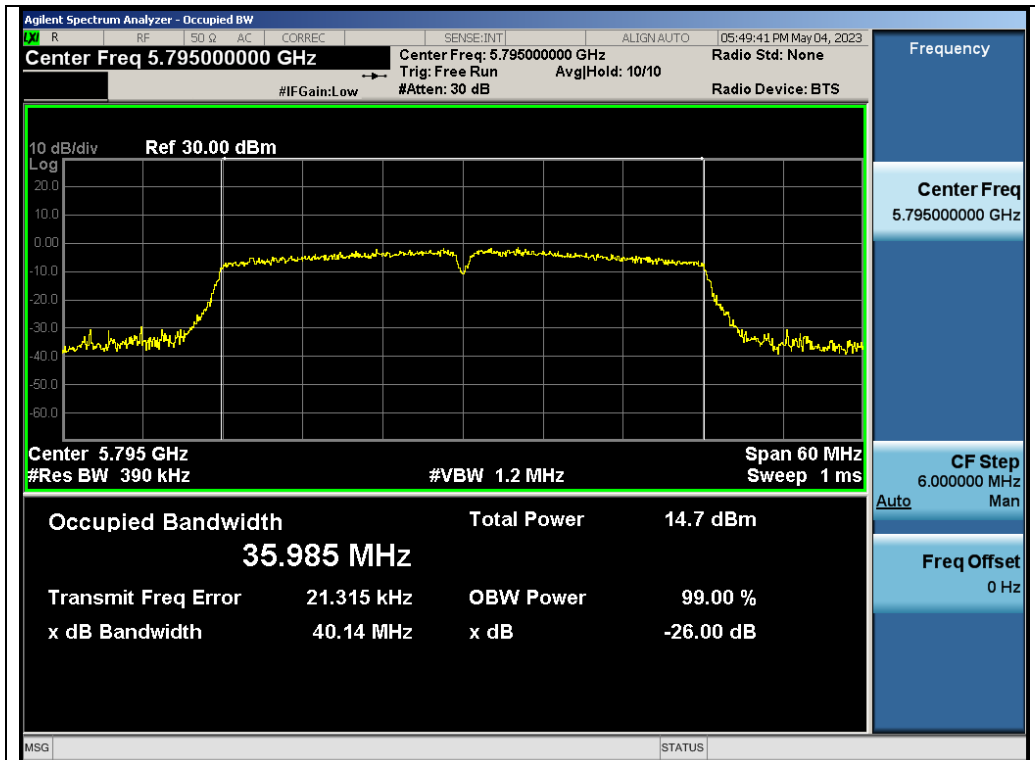

Test\_Graph\_802.11ac40\_ANT1\_5795\_MCS9\_OBW

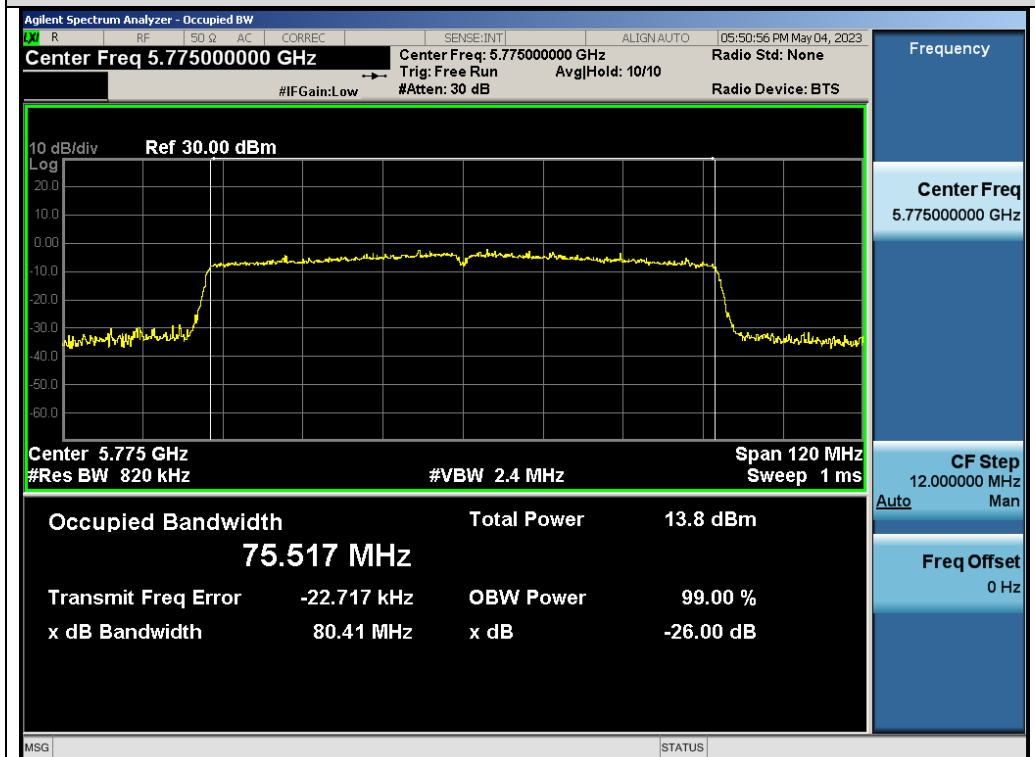

Test\_Graph\_802.11ac80\_ANT1\_5775\_MCS9\_OBW

Any report having not been signed by authorized approver, or having been altered without authorization, or having not been stamped by the "Dedicated Testing/Inspection Stamp" is deemed to be invalid. Copying or excerpting portion of, or altering the content of the report is not permitted without the written authorization of AGC. The test results presented in the report apply only to the tested sample. Any objections to report issued by AGC should be submitted to AGC within 15days after the issuance of the test report. Further enquiry of validity or verification of the test report should be addressed to AGC by agc01@agccert.com.

### Test Graphs of DTS Bandwidth for band 5.725-5.85 GHz

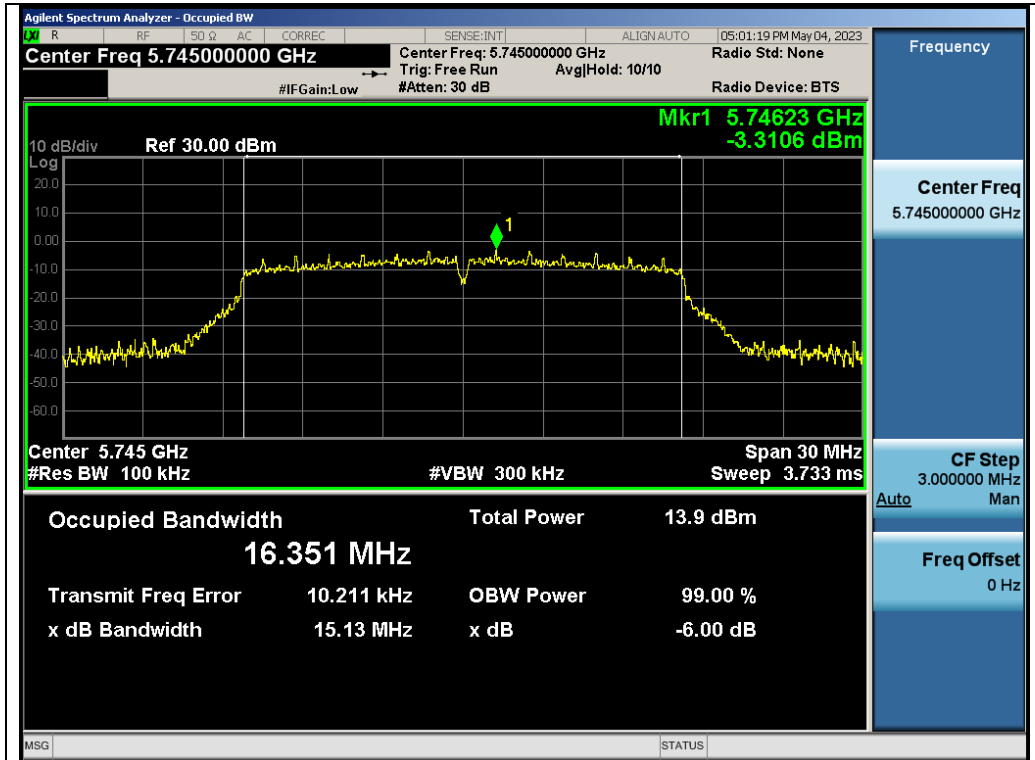

### Test\_Graph\_802.11a\_ANT1\_5745\_6Mbps\_DTSBW

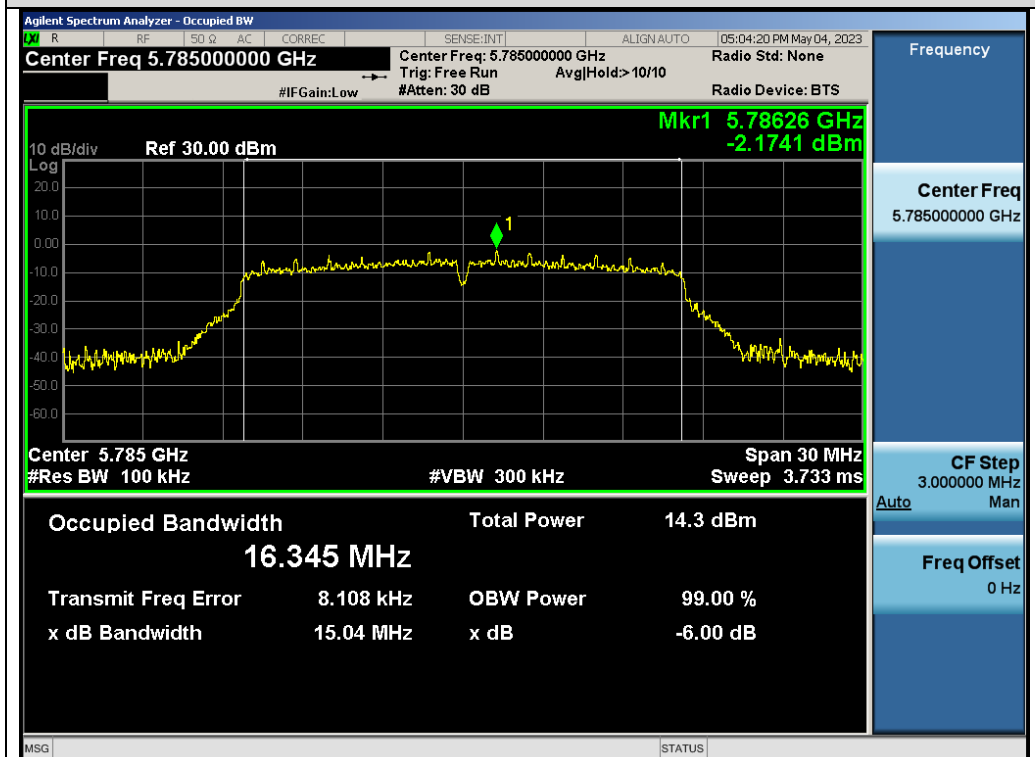

### Test\_Graph\_802.11a\_ANT1\_5785\_6Mbps\_DTSBW

Any report having not been signed by authorized approver, or having been altered without authorization, or having not been stamped by the "Dedicated Testing/Inspection Stamp" is deemed to be invalid. Copying or excerpting portion of, or altering the content of the report is not permitted without the written authorization of AGC. The test results presented in the report apply only to the tested sample. Any objections to report issued by AGC should be submitted to AGC within 15days after the issuance of the test report. Further enquiry of validity or verification of the test report should be addressed to AGC by agc01@agccert.com.



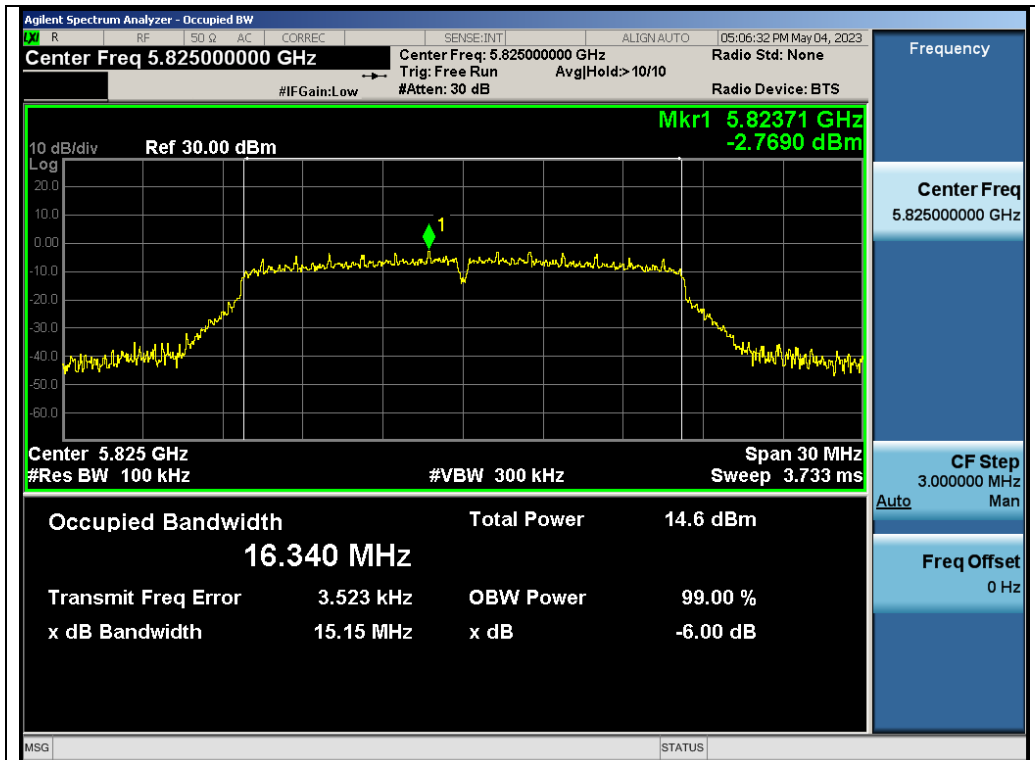

Test\_Graph\_802.11a\_ANT1\_5825\_6Mbps\_DTSBW

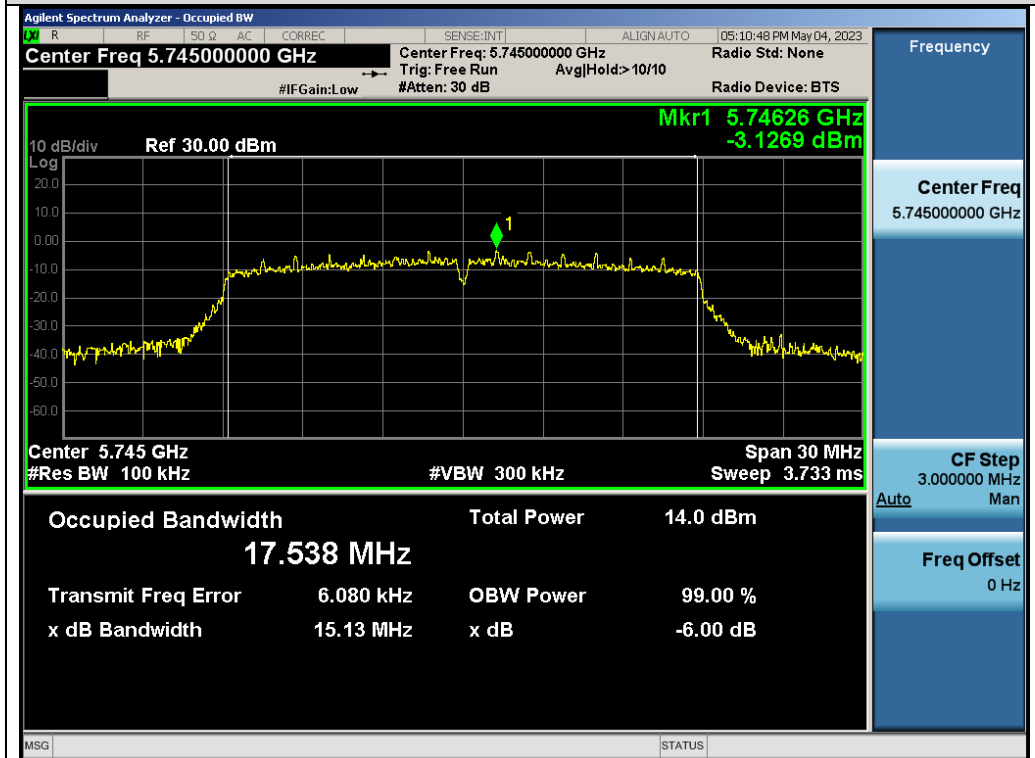

Test\_Graph\_802.11n20\_ANT1\_5745\_MCS0\_DTSBW

Any report having not been signed by authorized approver, or having been altered without authorization, or having not been stamped by the "Dedicated Testing/Inspection Stamp" is deemed to be invalid. Copying or excerpting portion of, or altering the content of the report is not permitted without the written authorization of AGC. The test results presented in the report apply only to the tested sample. Any objections to report issued by AGC should be submitted to AGC within 15 days after the issuance of the test report. Further enquiry of validity or verification of the test report should be addressed to AGC by agc01@agccert.com.



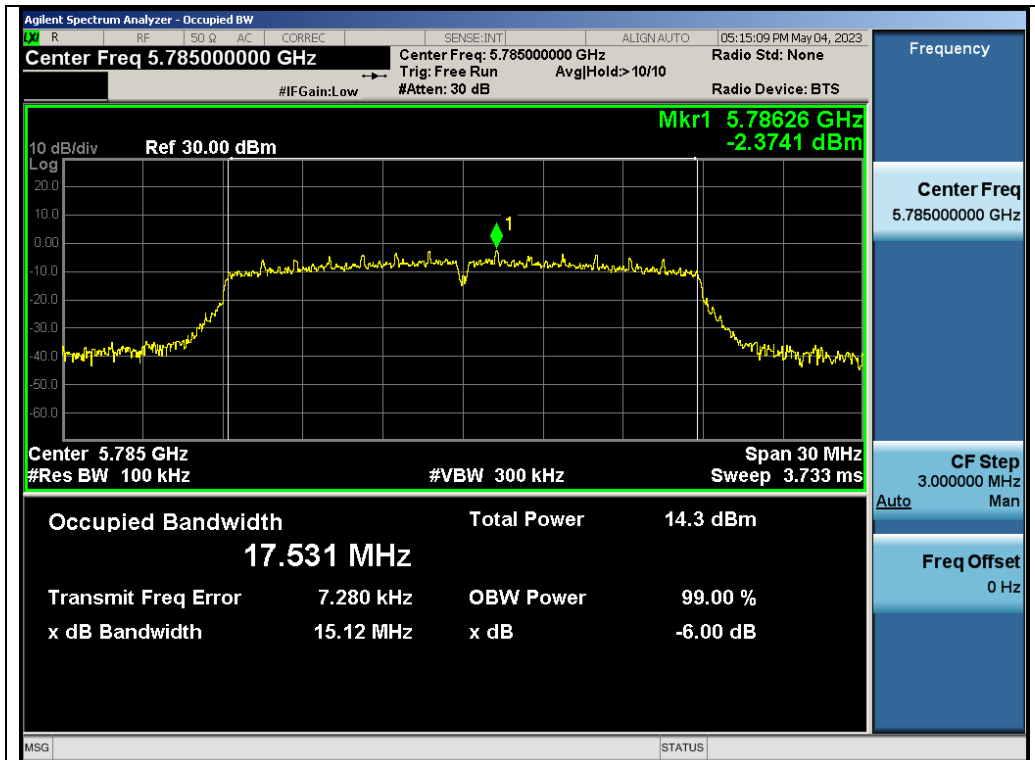

Test\_Graph\_802.11n20\_ANT1\_5785\_MCS0\_DTSBW

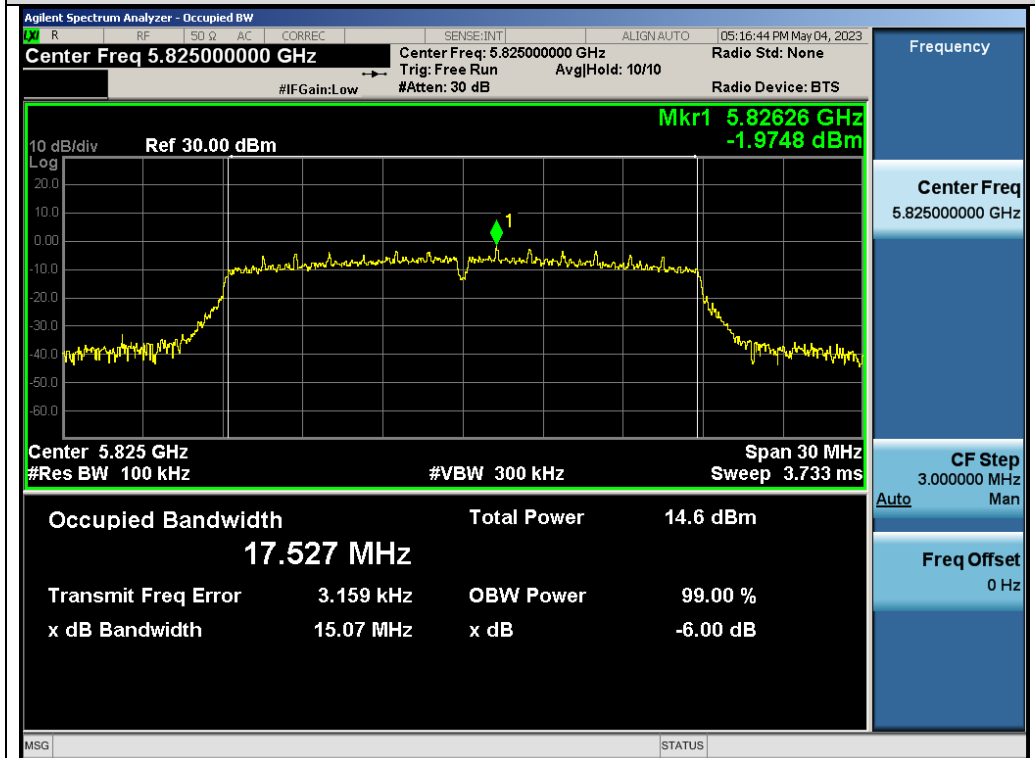

Test\_Graph\_802.11n20\_ANT1\_5825\_MCS0\_DTSBW

Any report having not been signed by authorized approver, or having been altered without authorization, or having not been stamped by the "Dedicated Testing/Inspection Stamp" is deemed to be invalid. Copying or excerpting portion of, or altering the content of the report is not permitted without the written authorization of AGC. The test results presented in the report apply only to the tested sample. Any objections to report issued by AGC should be submitted to AGC within 15days after the issuance of the test report. Further enquiry of validity or verification of the test report should be addressed to AGC by agc01@agccert.com.

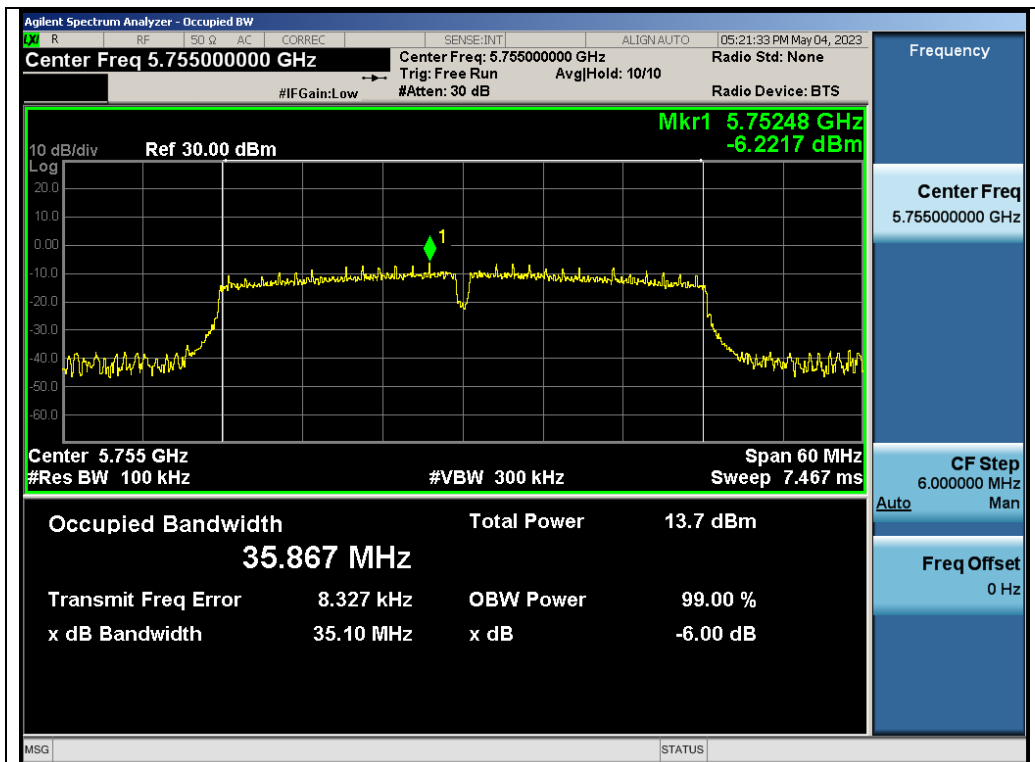

Test\_Graph\_802.11n40\_ANT1\_5755\_MCS0\_DTSBW

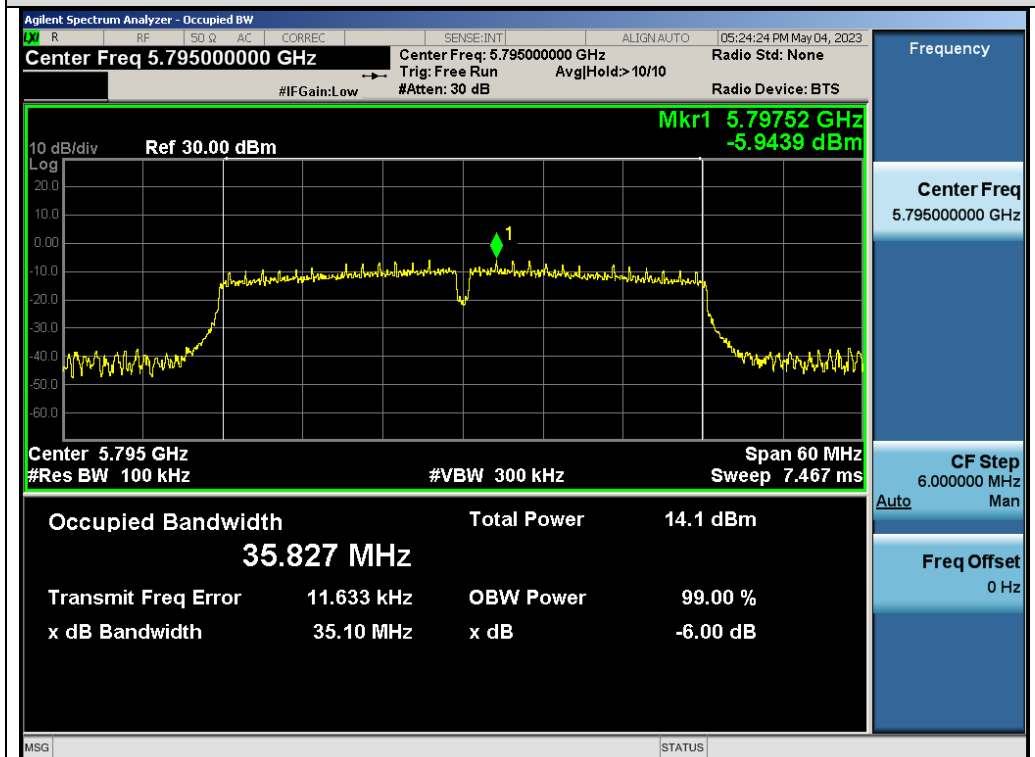

Test\_Graph\_802.11n40\_ANT1\_5795\_MCS0\_DTSBW

Any report having not been signed by authorized approver, or having been altered without authorization, or having not been stamped by the "Dedicated Testing/Inspection Stamp" is deemed to be invalid. Copying or excerpting portion of, or altering the content of the report is not permitted without the written authorization of AGC. The test results presented in the report apply only to the tested sample. Any objections to report issued by AGC should be submitted to AGC within 15days after the issuance of the test report. Further enquiry of validity or verification of the test report should be addressed to AGC by agc01@agccert.com.

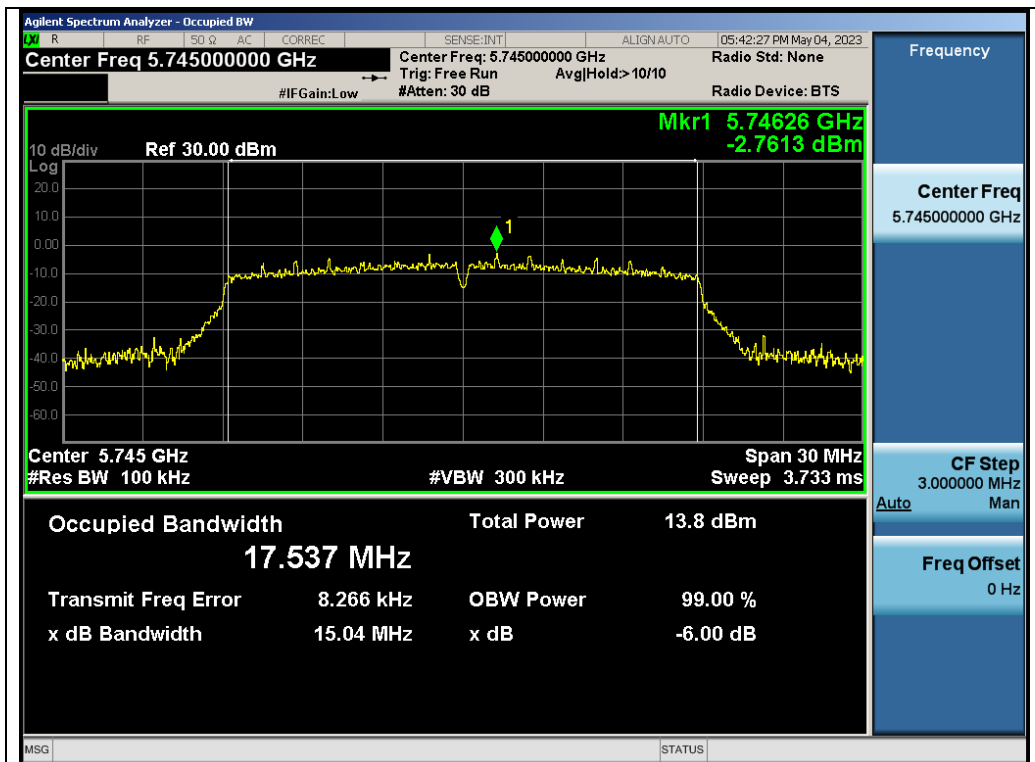

Test\_Graph\_802.11ac20\_ANT1\_5745\_MCS0\_DTSBW

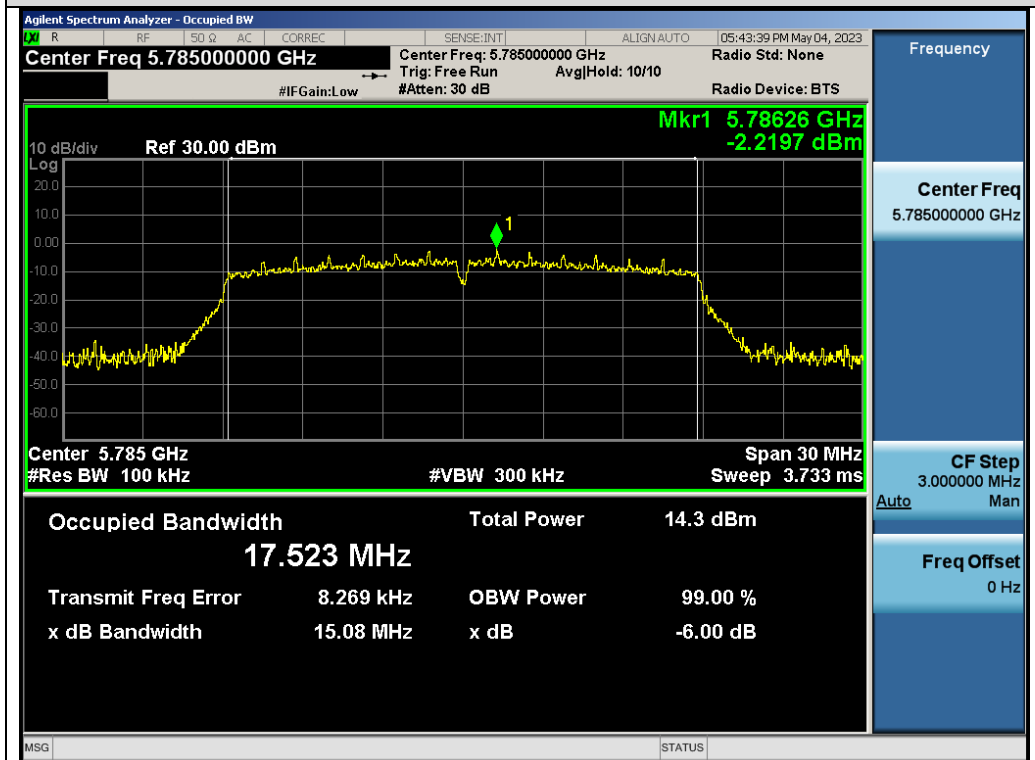

Test\_Graph\_802.11ac20\_ANT1\_5785\_MCS0\_DTSBW

Any report having not been signed by authorized approver, or having been altered without authorization, or having not been stamped by the "Dedicated Testing/Inspection Stamp" is deemed to be invalid. Copying or excerpting portion of, or altering the content of the report is not permitted without the written authorization of AGC. The test results presented in the report apply only to the tested sample. Any objections to report issued by AGC should be submitted to AGC within 15days after the issuance of the test report. Further enquiry of validity or verification of the test report should be addressed to AGC by agc01@agccert.com.

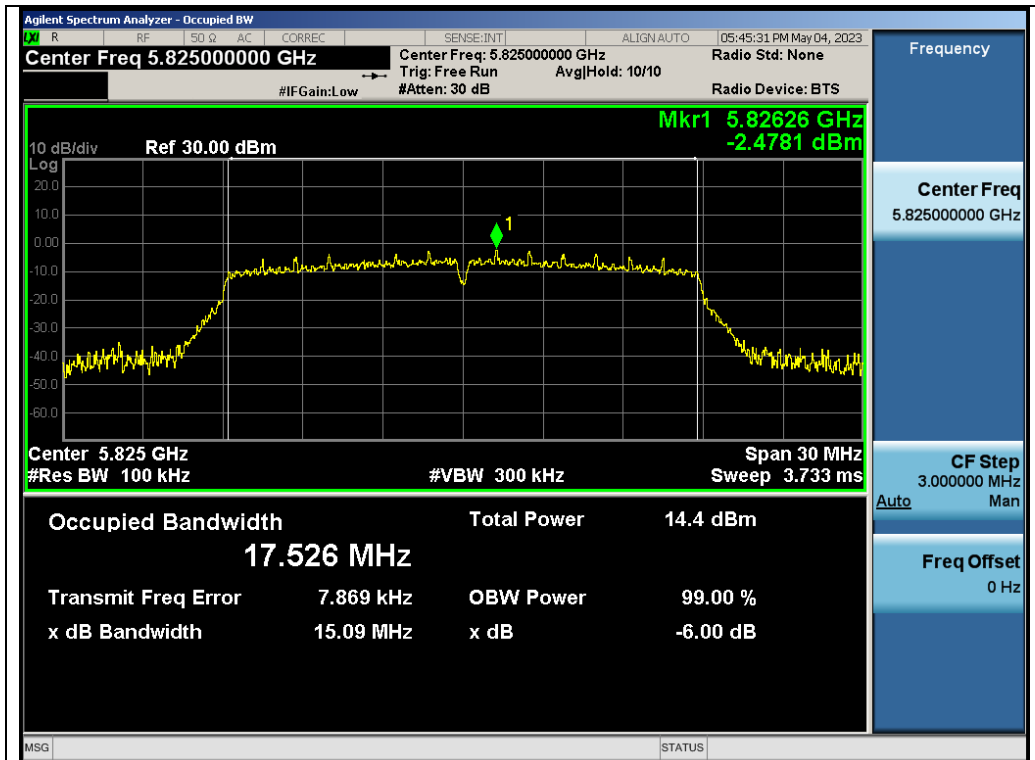

Test\_Graph\_802.11ac20\_ANT1\_5825\_MCS9\_DTSBW

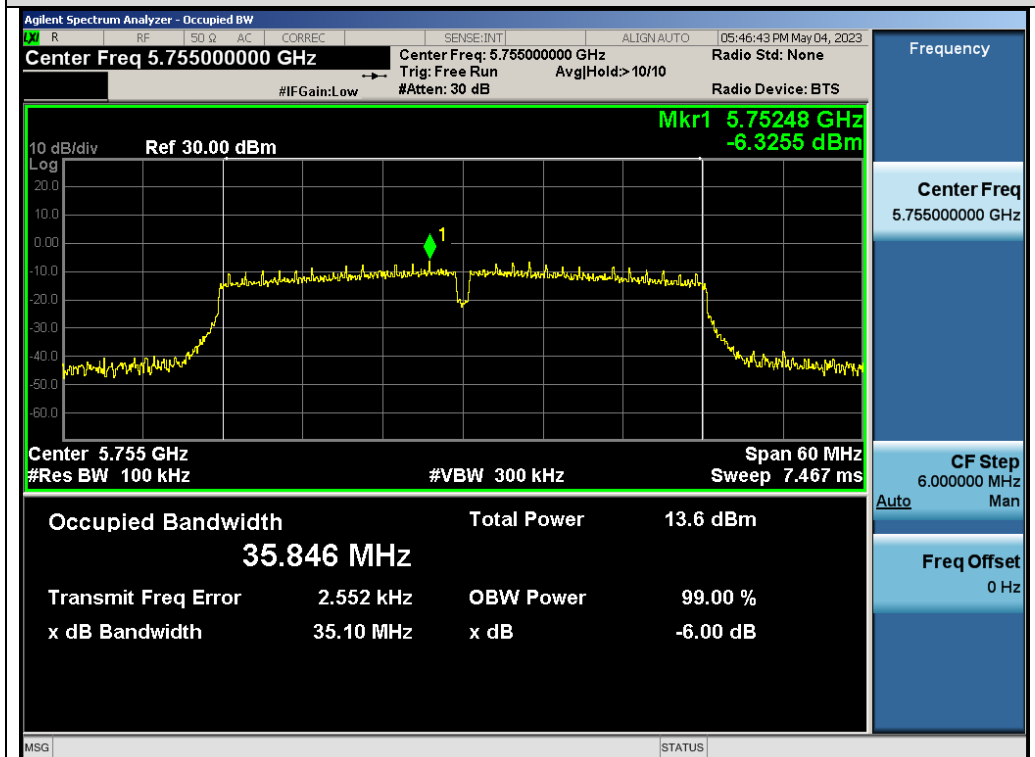

Test\_Graph\_802.11ac40\_ANT1\_5755\_MCS9\_DTSBW

Any report having not been signed by authorized approver, or having been altered without authorization, or having not been stamped by the "Dedicated Testing/Inspection Stamp" is deemed to be invalid. Copying or excerpting portion of, or altering the content of the report is not permitted without the written authorization of AGC. The test results presented in the report apply only to the tested sample. Any objections to report issued by AGC should be submitted to AGC within 15 days after the issuance of the test report. Further enquiry of validity or verification of the test report should be addressed to AGC by agc01@agccert.com.

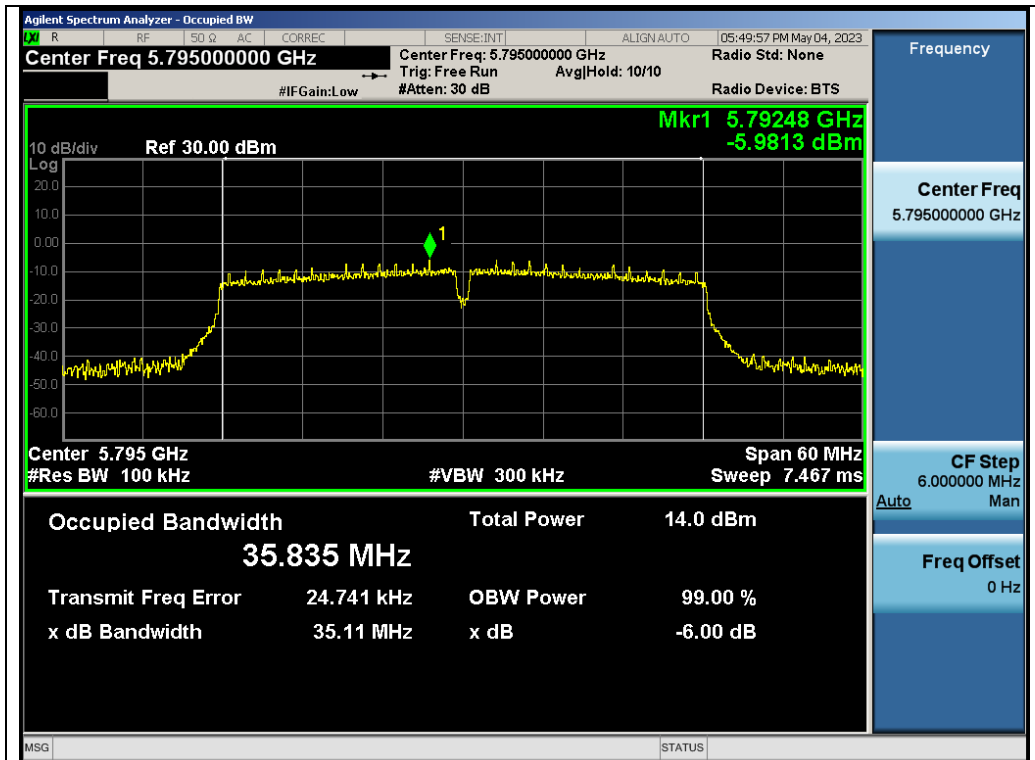

Test\_Graph\_802.11ac40\_ANT1\_5795\_MCS9\_DTSBW

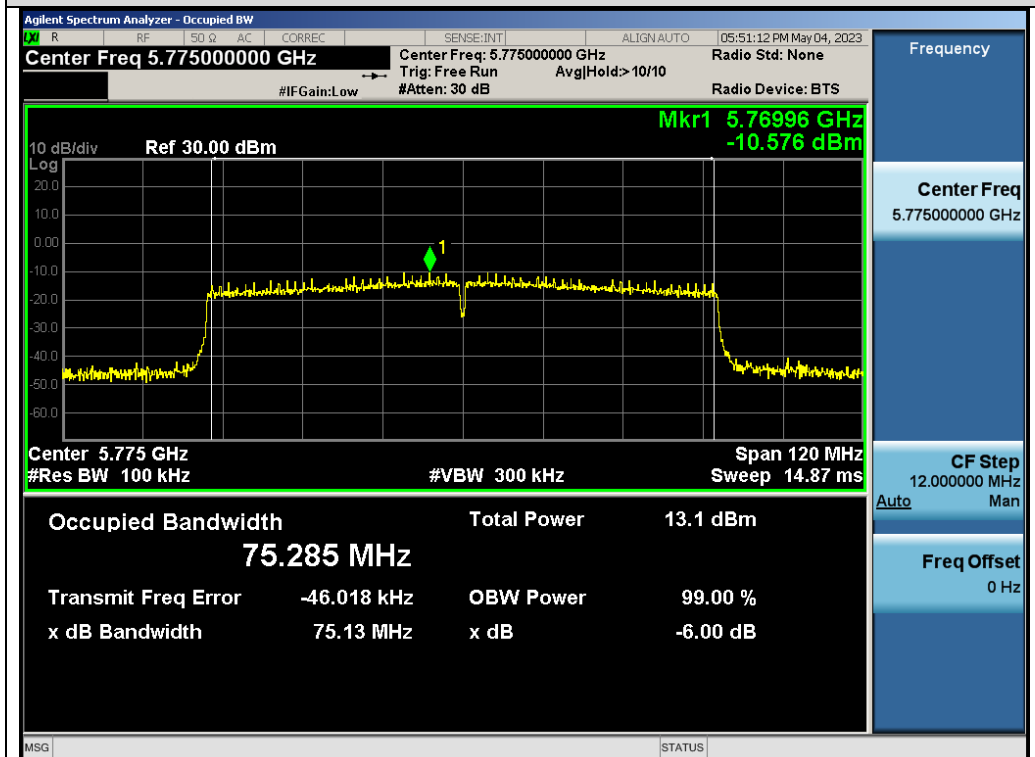

Test\_Graph\_802.11ac80\_ANT1\_5775\_MCS9\_DTSBW

Any report having not been signed by authorized approver, or having been altered without authorization, or having not been stamped by the "Dedicated Testing/Inspection Stamp" is deemed to be invalid. Copying or excerpting portion of, or altering the content of the report is not permitted without the written authorization of AGC. The test results presented in the report apply only to the tested sample. Any objections to report issued by AGC should be submitted to AGC within 15days after the issuance of the test report. Further enquiry of validity or verification of the test report should be addressed to AGC by agc01@agccert.com.

## 8. POWER SPECTRAL DENSITY MEASUREMENT

### 8.1 MEASUREMENT LIMITS

Operation Band	EUT Category		LIMIT
U-NII-1	<input type="checkbox"/>	Outdoor Access Point	17dBm/ MHz
	<input type="checkbox"/>	Fixed point-to-point Access Point	17dBm/ MHz
	<input type="checkbox"/>	Indoor Access Point	17dBm/ MHz
	<input checked="" type="checkbox"/>	Client devices	11dBm/ MHz
U-NII-2A	/		11dBm/ MHz
U-NII-2C	/		11dBm/ MHz
U-NII-3	/		30 dBm/500kHz

### 8.2 MEASUREMENT PROCEDURE

For Average power spectral density test:

1. Connect EUT RF output port to the Spectrum Analyzer through an RF attenuator.
2. Span was set to encompass the entire 26dB EBW of the signal.
3. RBW = 1MHz.
4. If measurement bandwidth of Maximum PSD is specified in 500 kHz, RBW = 100KHz
5. Set VBW  $\geq$  [3 $\times$ RBW].
6. Sweep Time=Auto couple.
7. Detector function=RMS (i.e., power averaging).
8. Trace average at least 100 traces in power averaging (rms) mode.
9. When the measurement bandwidth of Maximum PSD is specified in 100 kHz, add a constant factor  $10 \cdot \log(500\text{kHz}/100\text{kHz}) = 6.99$  dB to the measured result.
10. Determine according to the duty cycle of the equipment: when it is less than 98%, follow the steps below.
11. Add [10 log (1/D)], where D is the duty cycle, to the measured power to compute the average power during the actual transmission times (because the measurement represents an average over both the ON and OFF times of the transmission). For example, add [10 log (1/0.25)] = 6 dB if the duty cycle is 25%.
12. Record the test results in the report.

### 8.3 MEASUREMENT SETUP (BLOCK DIAGRAM OF CONFIGURATION)

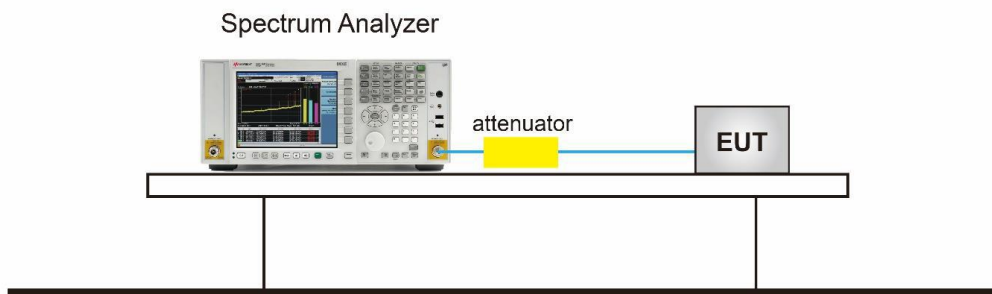

Any report having not been signed by authorized approver, or having been altered without authorization, or having not been stamped by the "Dedicated Testing/Inspection Stamp" is deemed to be invalid. Copying or excerpting portion of, or altering the content of the report is not permitted without the written authorization of AGC. The test results presented in the report apply only to the tested sample. Any objections to report issued by AGC should be submitted to AGC within 15days after the issuance of the test report. Further enquiry of validity or verification of the test report should be addressed to AGC by agc01@agccert.com.

#### 8.4 MEASUREMENT RESULT

Test Data of Conducted Output Power Density for band 5.15-5.25 GHz				
Test Mode	Test Channel (MHz)	Average Power Density (dBm/MHz)	Limits (dBm/MHz)	Pass or Fail
802.11a	5180	0.290	11	Pass
	5200	-0.164	11	Pass
	5240	-0.609	11	Pass
802.11n20	5180	-0.051	11	Pass
	5200	-0.434	11	Pass
	5240	-0.793	11	Pass
802.11n40	5190	-2.890	11	Pass
	5230	-3.215	11	Pass
802.11ac20	5180	-0.359	11	Pass
	5200	-0.192	11	Pass
	5240	-0.860	11	Pass
802.11ac40	5190	-2.799	11	Pass
	5230	-3.147	11	Pass
802.11ac80	5210	-5.801	11	Pass

Test Data of Conducted Output Power Density for band 5.25-5.35 GHz				
Test Mode	Test Channel (MHz)	Average Power Density (dBm/MHz)	Limits (dBm/MHz)	Pass or Fail
802.11a	5260	-0.490	11	Pass
	5300	-1.310	11	Pass
	5320	-1.772	11	Pass
802.11n20	5260	-1.441	11	Pass
	5300	-1.579	11	Pass
	5320	-2.034	11	Pass
802.11n40	5270	-4.046	11	Pass
	5310	-4.466	11	Pass
802.11ac20	5260	-1.396	11	Pass
	5300	-1.808	11	Pass
	5320	-1.950	11	Pass
802.11ac40	5270	-4.051	11	Pass
	5310	-4.243	11	Pass
802.11ac80	5290	-7.307	11	Pass

Any report having not been signed by authorized approver, or having been altered without authorization, or having not been stamped by the "Dedicated Testing/Inspection Stamp" is deemed to be invalid. Copying or excerpting portion of, or altering the content of the report is not permitted without the written authorization of AGC. The test results presented in the report apply only to the tested sample. Any objections to report issued by AGC should be submitted to AGC within 15days after the issuance of the test report. Further enquiry of validity or verification of the test report should be addressed to AGC by agc01@agccert.com.



Test Data of Conducted Output Power Density for band 5.470-5.725 GHz				
Test Mode	Test Channel (MHz)	Average Power Density (dBm/MHz)	Limits (dBm/MHz)	Pass or Fail
802.11a	5500	-0.058	11	Pass
	5600	-0.310	11	Pass
	5700	-1.957	11	Pass
802.11n20	5500	-0.219	11	Pass
	5600	-0.766	11	Pass
	5700	-2.320	11	Pass
802.11n40	5510	-2.534	11	Pass
	5590	-2.755	11	Pass
	5670	-4.799	11	Pass
802.11ac20	5500	-0.083	11	Pass
	5600	-0.874	11	Pass
	5700	-2.397	11	Pass
802.11ac40	5510	-2.684	11	Pass
	5590	-3.160	11	Pass
	5670	-4.819	11	Pass
802.11ac80	5530	-5.319	11	Pass
	5610	-5.972	11	Pass

Any report having not been signed by authorized approver, or having been altered without authorization, or having not been stamped by the "Dedicated Testing/Inspection Stamp" is deemed to be invalid. Copying or excerpting portion of, or altering the content of the report is not permitted without the written authorization of AGC. The test results presented in the report apply only to the tested sample. Any objections to report issued by AGC should be submitted to AGC within 15days after the issuance of the test report. Further enquiry of validity or verification of the test report should be addressed to AGC by agc01@agccert.com.



Test Data of Conducted Output Power Density for band 5.725-5.85 GHz					
Test Mode	Test Channel (MHz)	Average Power Density (dBm/100kHz)	Average Power Density (dBm/500kHz)	Limits (dBm/500kHz)	Pass or Fail
802.11a	5745	-10.189	-3.199	30	Pass
	5785	-10.255	-3.265	30	Pass
	5825	-9.987	-2.997	30	Pass
802.11n20	5745	-10.817	-3.827	30	Pass
	5785	-10.656	-3.666	30	Pass
	5825	-10.148	-3.158	30	Pass
802.11n40	5755	-13.513	-6.523	30	Pass
	5795	-13.64	-6.650	30	Pass
802.11ac20	5745	-11.005	-4.015	30	Pass
	5785	-10.851	-3.861	30	Pass
	5825	-10.177	-3.187	30	Pass
802.11ac40	5755	-13.814	-6.824	30	Pass
	5795	-13.366	-6.376	30	Pass
802.11ac80	5775	-15.99	-9.000	30	Pass

Note: 1. Power density (dBm/500kHz) = Power density (dBm/100kHz) + 10 \* log(500/100).

2. The Total PSD (dBm/500kHz) =  $10^{\text{Ant 1 PSD}/10} + 10^{\text{Ant 2 PSD}/10}$  (dBm/500kHz).

Any report having not been signed by authorized approver, or having been altered without authorization, or having not been stamped by the "Dedicated Testing/Inspection Stamp" is deemed to be invalid. Copying or excerpting portion of, or altering the content of the report is not permitted without the written authorization of AGC. The test results presented in the report apply only to the tested sample. Any objections to report issued by AGC should be submitted to AGC within 15 days after the issuance of the test report. Further enquiry of validity or verification of the test report should be addressed to AGC by agc01@agccert.com.

Test Graphs of Conducted Output Power Spectral Density for band 5.15-5.25 GHz

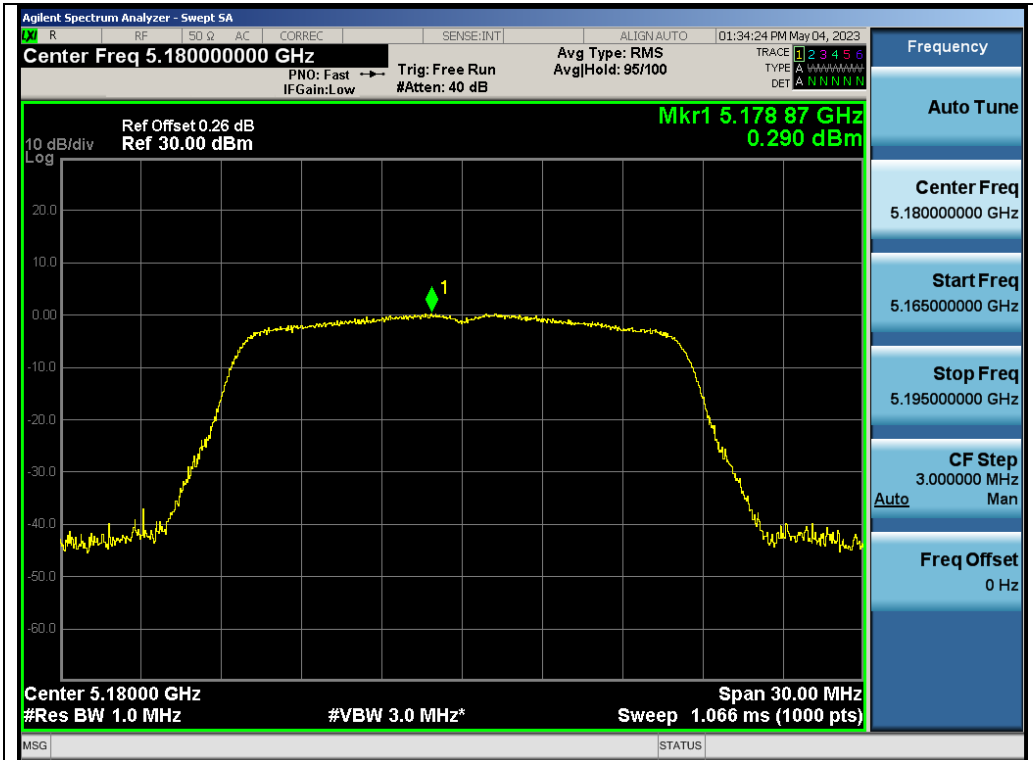

Test\_Graph\_802.11a\_ANT1\_5180\_6Mbps\_PSD

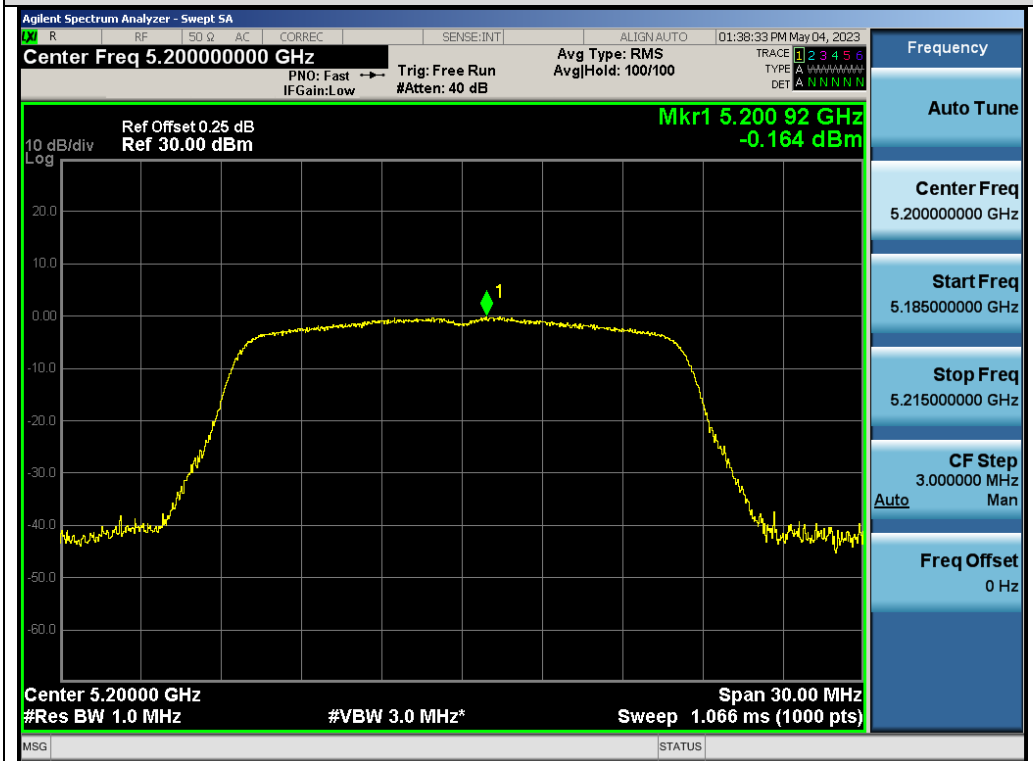

Test\_Graph\_802.11a\_ANT1\_5200\_6Mbps\_PSD

Any report having not been signed by authorized approver, or having been altered without authorization, or having not been stamped by the "Dedicated Testing/Inspection Stamp" is deemed to be invalid. Copying or excerpting portion of, or altering the content of the report is not permitted without the written authorization of AGC. The test results presented in the report apply only to the tested sample. Any objections to report issued by AGC should be submitted to AGC within 15days after the issuance of the test report. Further enquiry of validity or verification of the test report should be addressed to AGC by agc01@agccert.com.

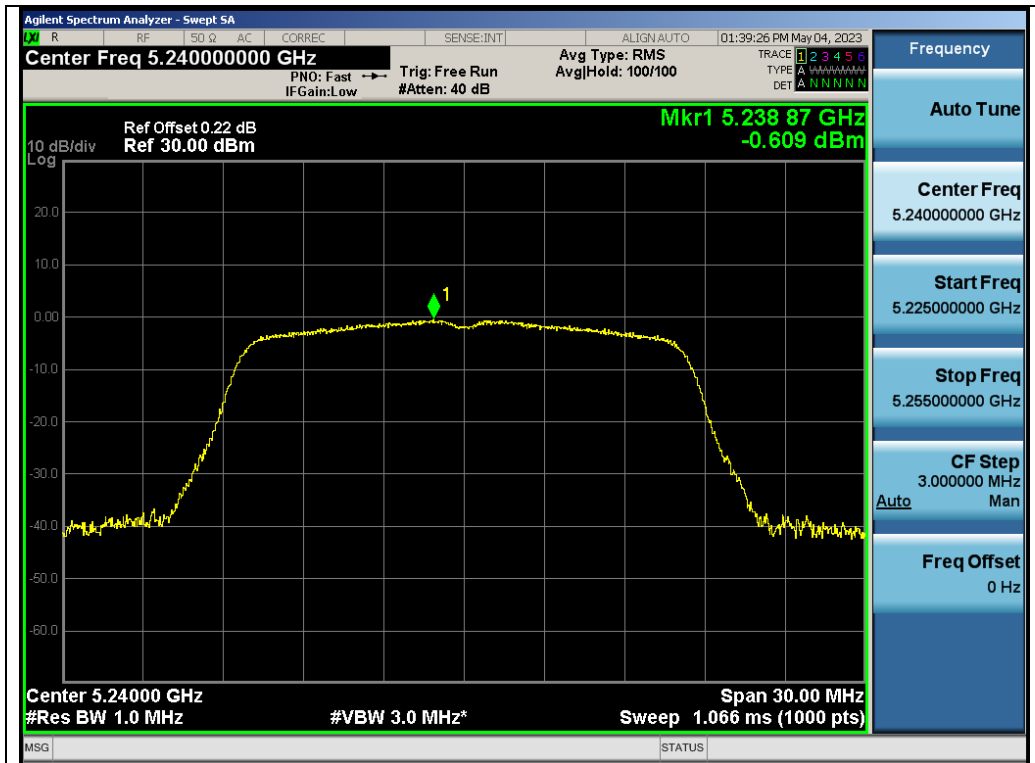

Test\_Graph\_802.11a\_ANT1\_5240\_6Mbps\_PSD

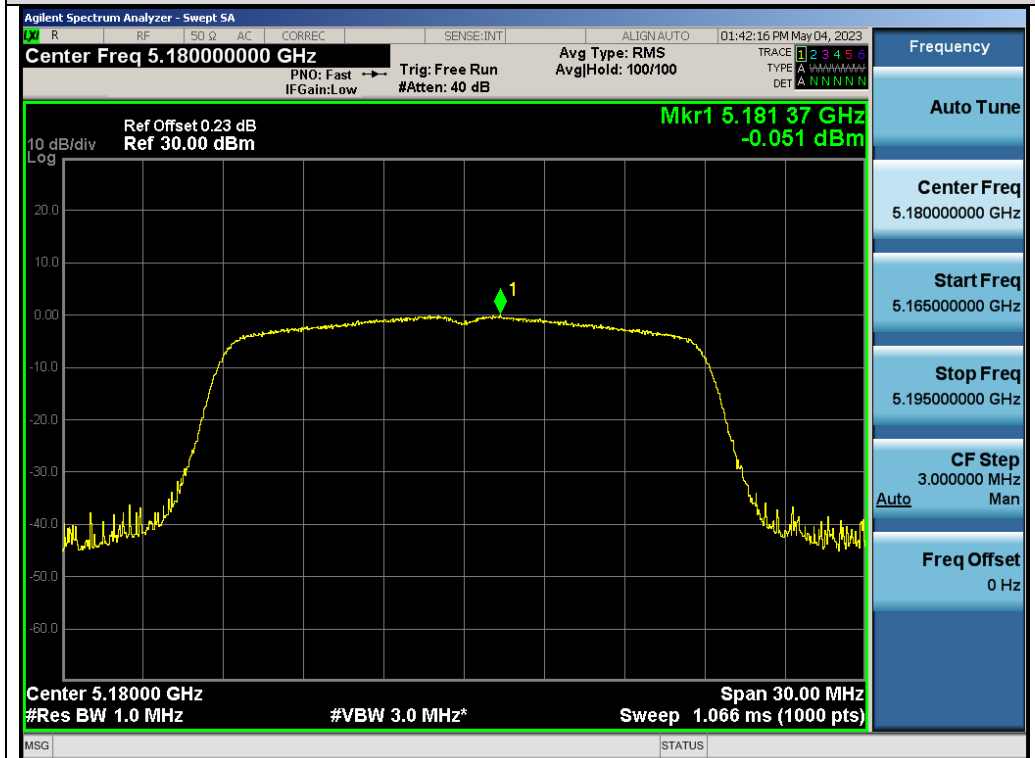

Test\_Graph\_802.11n20\_ANT1\_5180\_MCS0\_PSD

Any report having not been signed by authorized approver, or having been altered without authorization, or having not been stamped by the "Dedicated Testing/Inspection Stamp" is deemed to be invalid. Copying or excerpting portion of, or altering the content of the report is not permitted without the written authorization of AGC. The test results presented in the report apply only to the tested sample. Any objections to report issued by AGC should be submitted to AGC within 15days after the issuance of the test report. Further enquiry of validity or verification of the test report should be addressed to AGC by agc01@agccert.com.

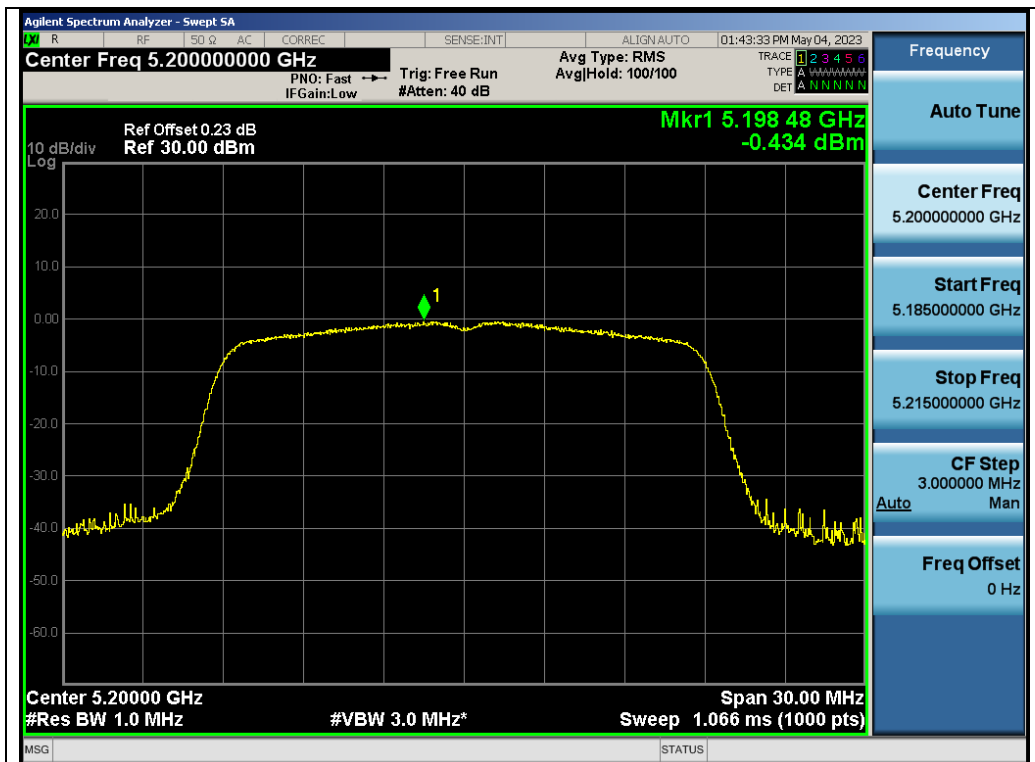

Test\_Graph\_802.11n20\_ANT1\_5200\_MCS0\_PSD

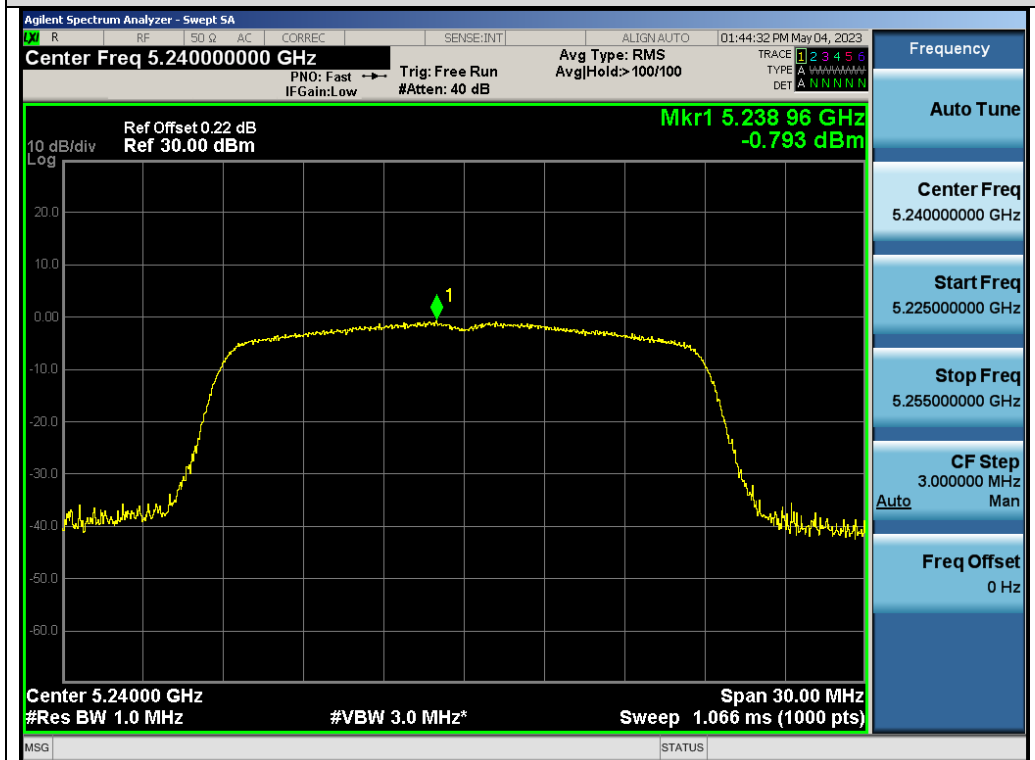

Test\_Graph\_802.11n20\_ANT1\_5240\_MCS0\_PSD

Any report having not been signed by authorized approver, or having been altered without authorization, or having not been stamped by the "Dedicated Testing/Inspection Stamp" is deemed to be invalid. Copying or excerpting portion of, or altering the content of the report is not permitted without the written authorization of AGC. The test results presented in the report apply only to the tested sample. Any objections to report issued by AGC should be submitted to AGC within 15days after the issuance of the test report. Further enquiry of validity or verification of the test report should be addressed to AGC by agc01@agccert.com.

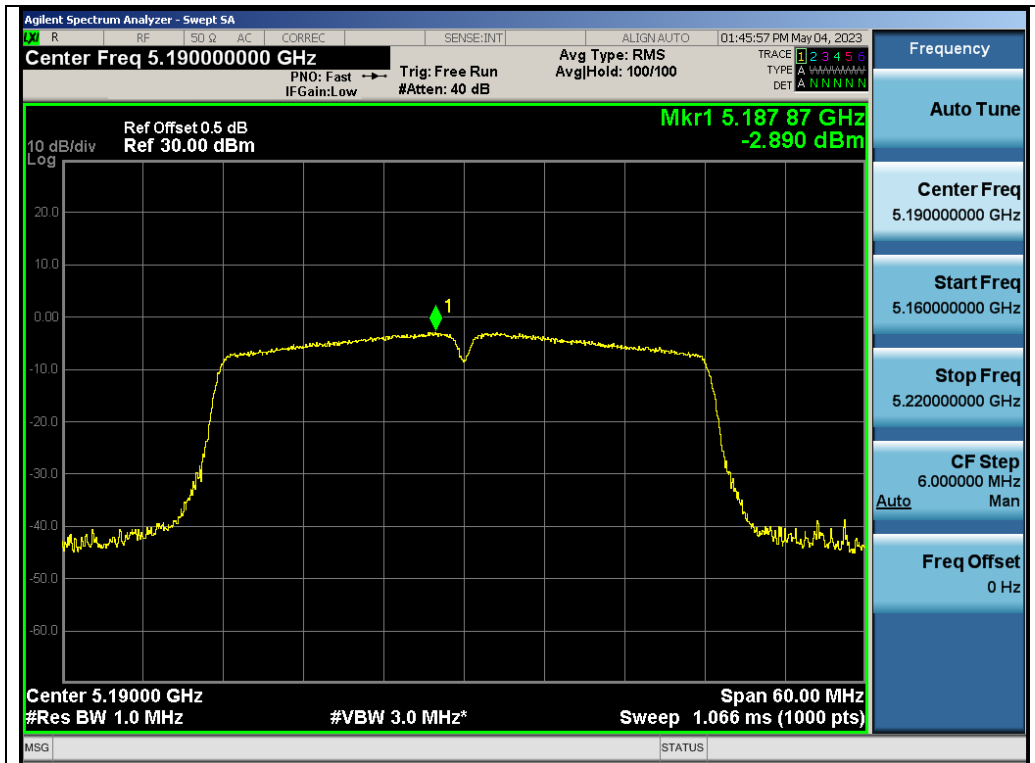

Test\_Graph\_802.11n40\_ANT1\_5190\_MCS0\_PSD

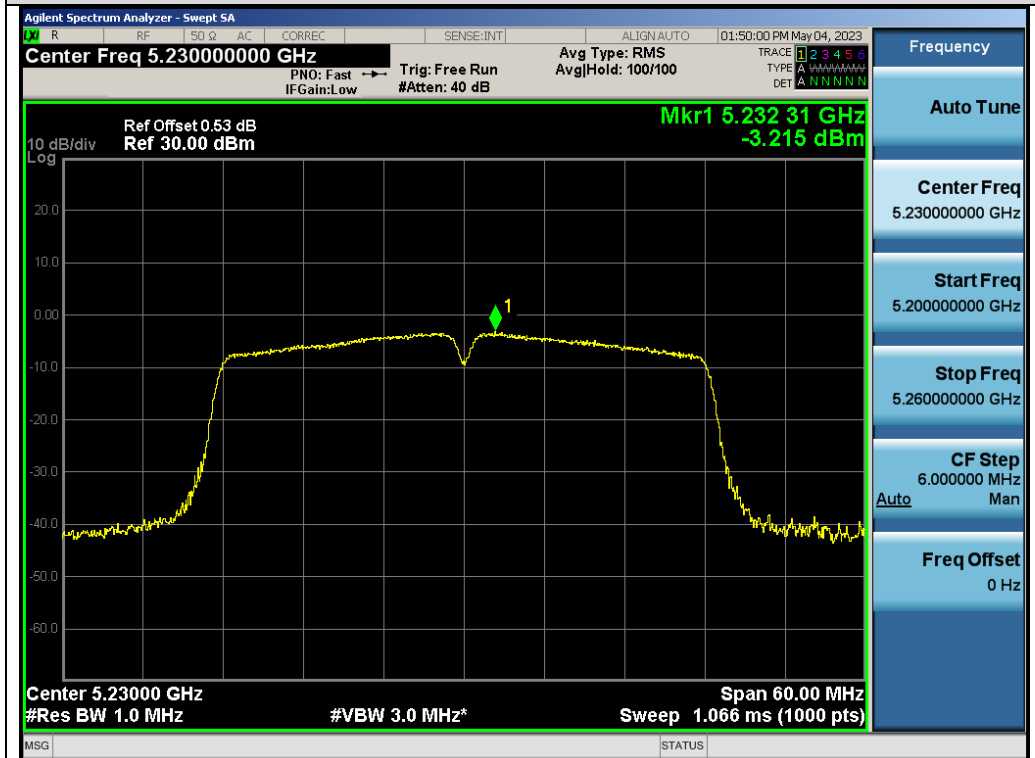

Test\_Graph\_802.11n40\_ANT1\_5230\_MCS0\_PSD

Any report having not been signed by authorized approver, or having been altered without authorization, or having not been stamped by the "Dedicated Testing/Inspection Stamp" is deemed to be invalid. Copying or excerpting portion of, or altering the content of the report is not permitted without the written authorization of AGC. The test results presented in the report apply only to the tested sample. Any objections to report issued by AGC should be submitted to AGC within 15days after the issuance of the test report. Further enquiry of validity or verification of the test report should be addressed to AGC by agc01@agccert.com.

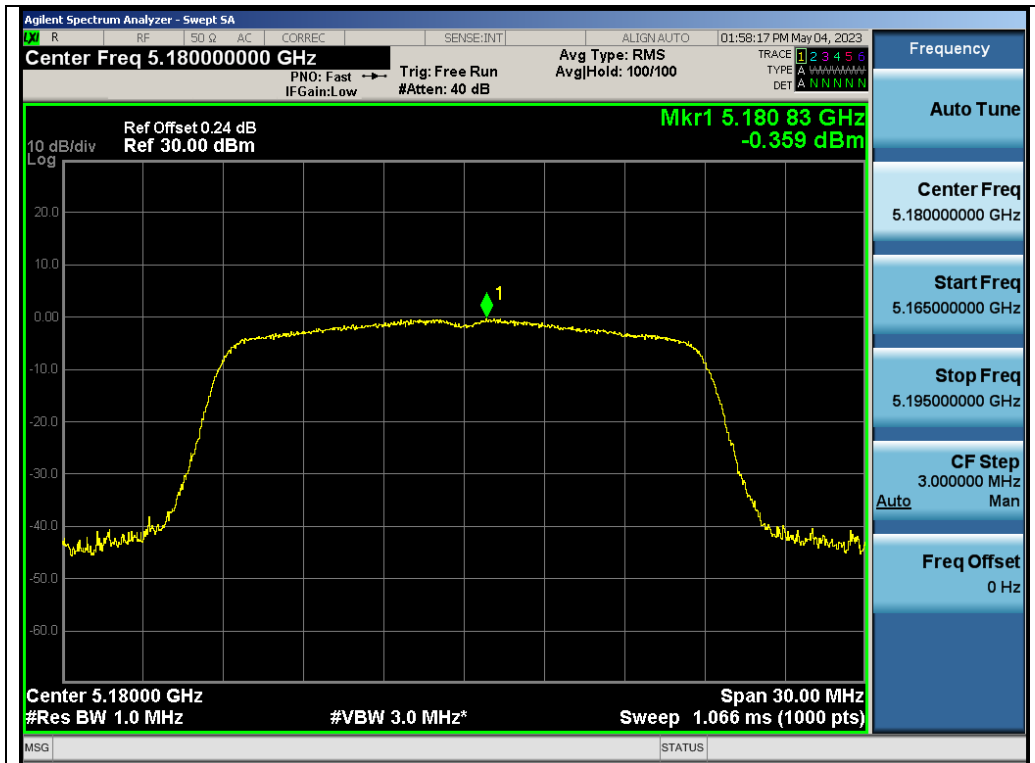

Test\_Graph\_802.11ac20\_ANT1\_5180\_MCS0\_PSD

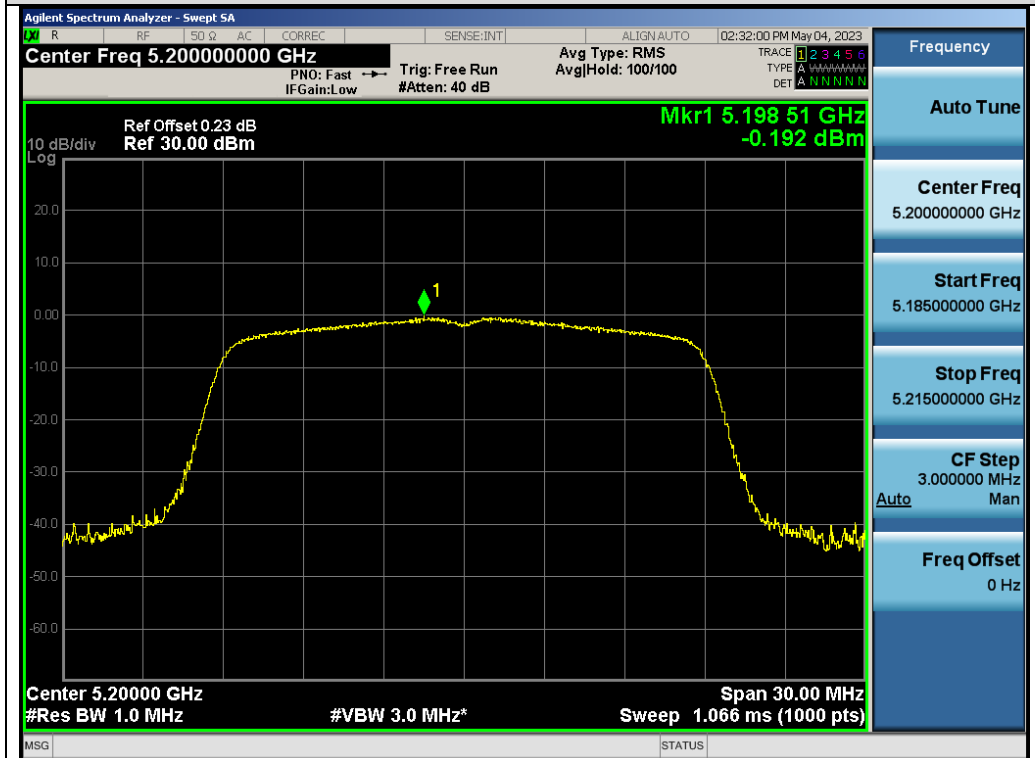

Test\_Graph\_802.11ac20\_ANT1\_5200\_MCS0\_PSD

Any report having not been signed by authorized approver, or having been altered without authorization, or having not been stamped by the "Dedicated Testing/Inspection Stamp" is deemed to be invalid. Copying or excerpting portion of, or altering the content of the report is not permitted without the written authorization of AGC. The test results presented in the report apply only to the tested sample. Any objections to report issued by AGC should be submitted to AGC within 15days after the issuance of the test report. Further enquiry of validity or verification of the test report should be addressed to AGC by agc01@agccert.com.

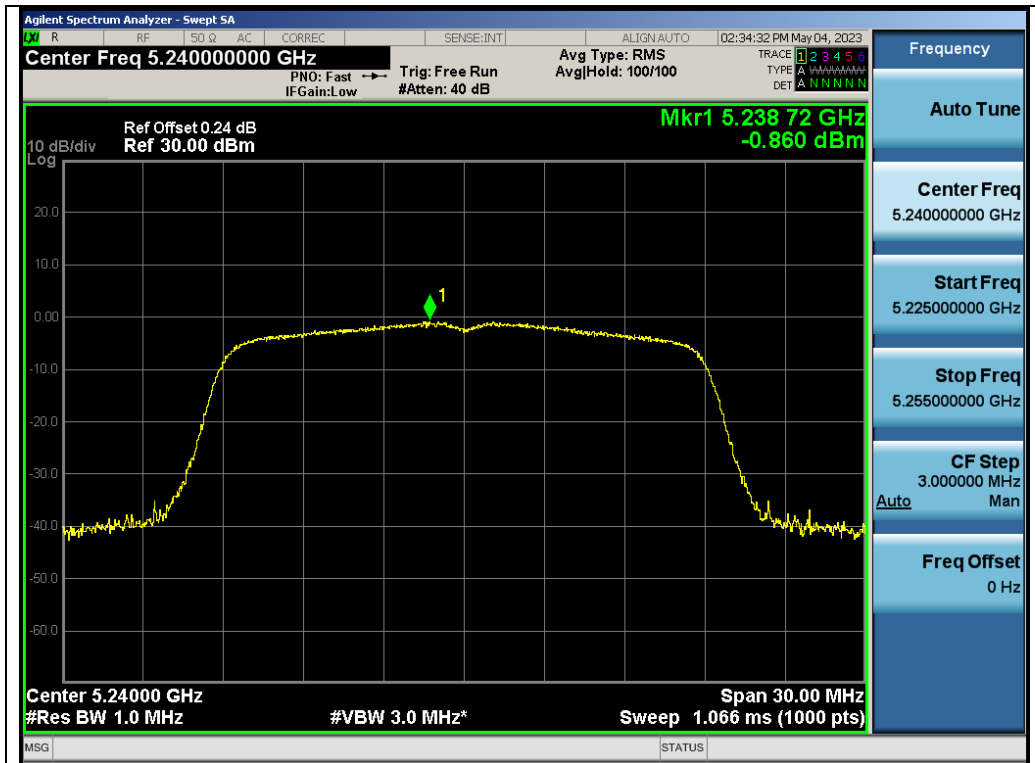

Test\_Graph\_802.11ac20\_ANT1\_5240\_MCS0\_PSD

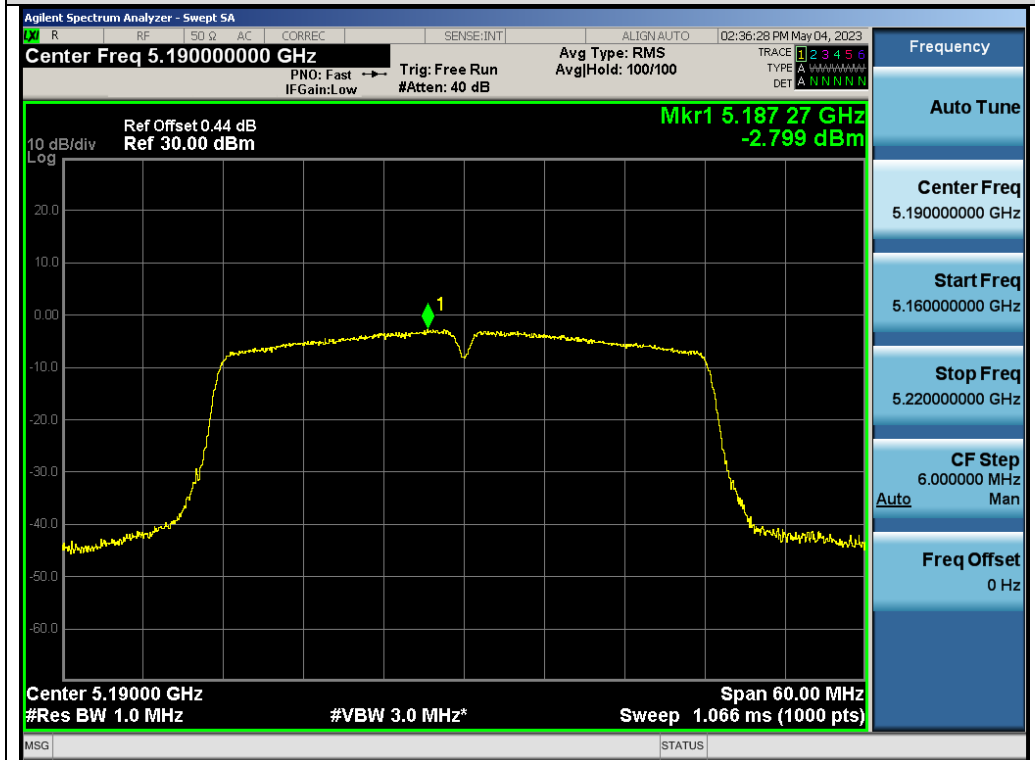

Test\_Graph\_802.11ac40\_ANT1\_5190\_MCS0\_PSD

Any report having not been signed by authorized approver, or having been altered without authorization, or having not been stamped by the "Dedicated Testing/Inspection Stamp" is deemed to be invalid. Copying or excerpting portion of, or altering the content of the report is not permitted without the written authorization of AGC. The test results presented in the report apply only to the tested sample. Any objections to report issued by AGC should be submitted to AGC within 15days after the issuance of the test report. Further enquiry of validity or verification of the test report should be addressed to AGC by agc01@agccert.com.

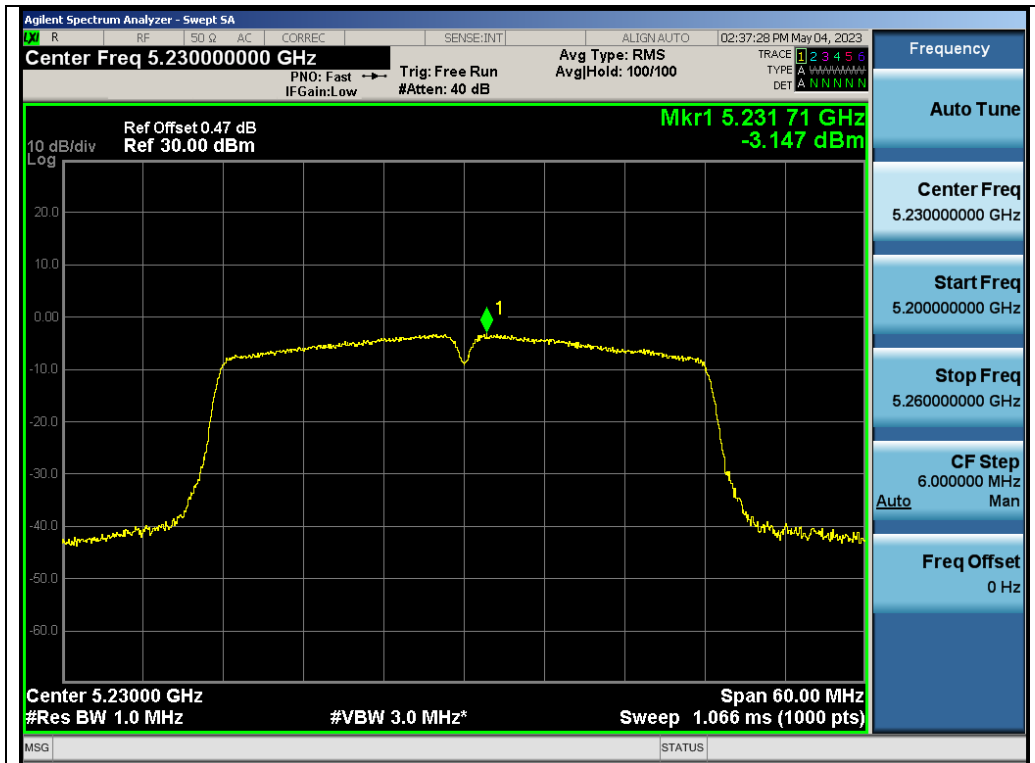

Test\_Graph\_802.11ac40\_ANT1\_5230\_MCS0\_PSD

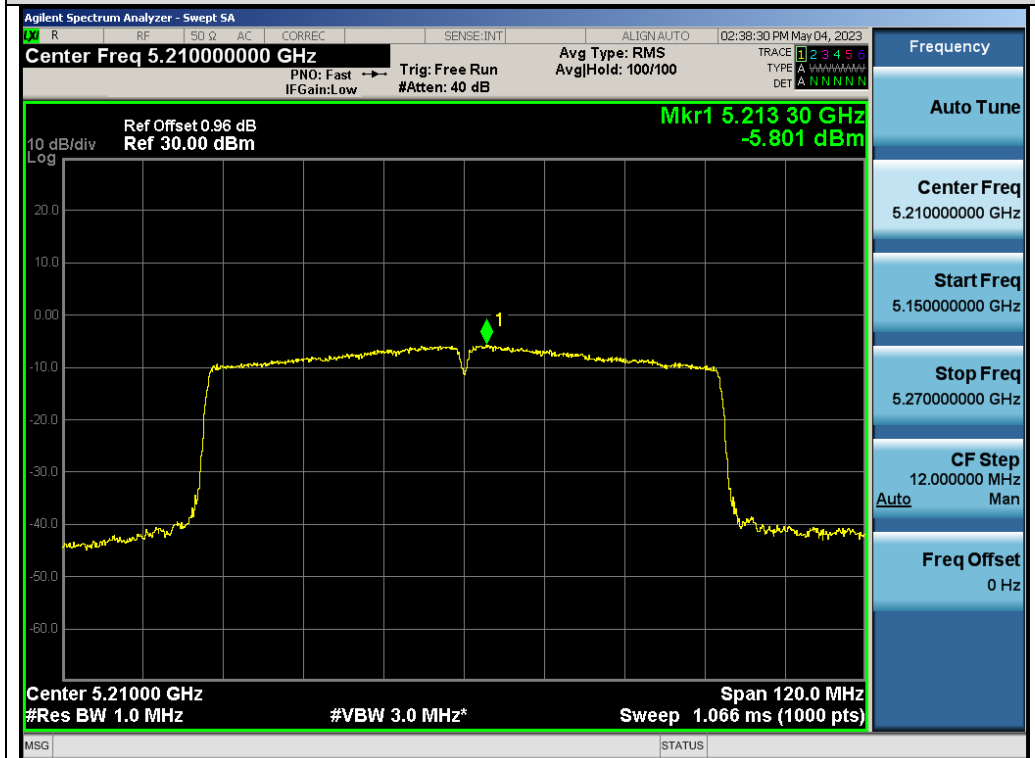

Test\_Graph\_802.11ac80\_ANT1\_5210\_MCS0\_PSD

Any report having not been signed by authorized approver, or having been altered without authorization, or having not been stamped by the "Dedicated Testing/Inspection Stamp" is deemed to be invalid. Copying or excerpting portion of, or altering the content of the report is not permitted without the written authorization of AGC. The test results presented in the report apply only to the tested sample. Any objections to report issued by AGC should be submitted to AGC within 15days after the issuance of the test report. Further enquiry of validity or verification of the test report should be addressed to AGC by agc01@agccert.com.



Test Graphs of Conducted Output Power Spectral Density for band 5.25-5.35 GHz

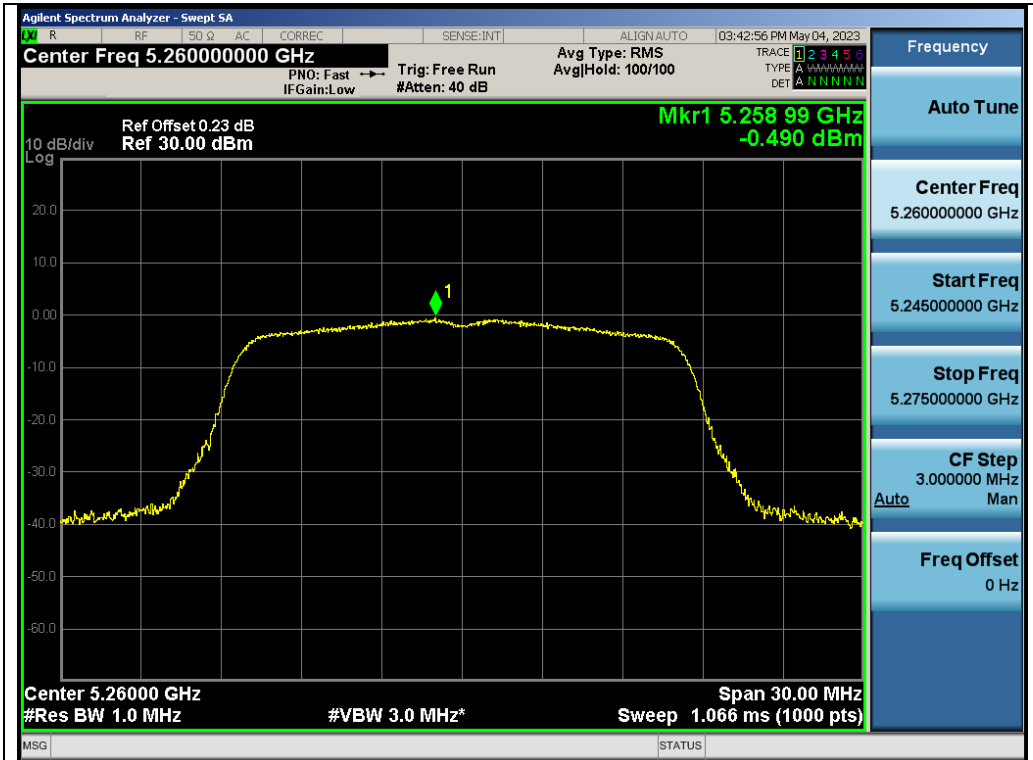

Test\_Graph\_802.11a\_ANT1\_5260\_6Mbps\_PSD

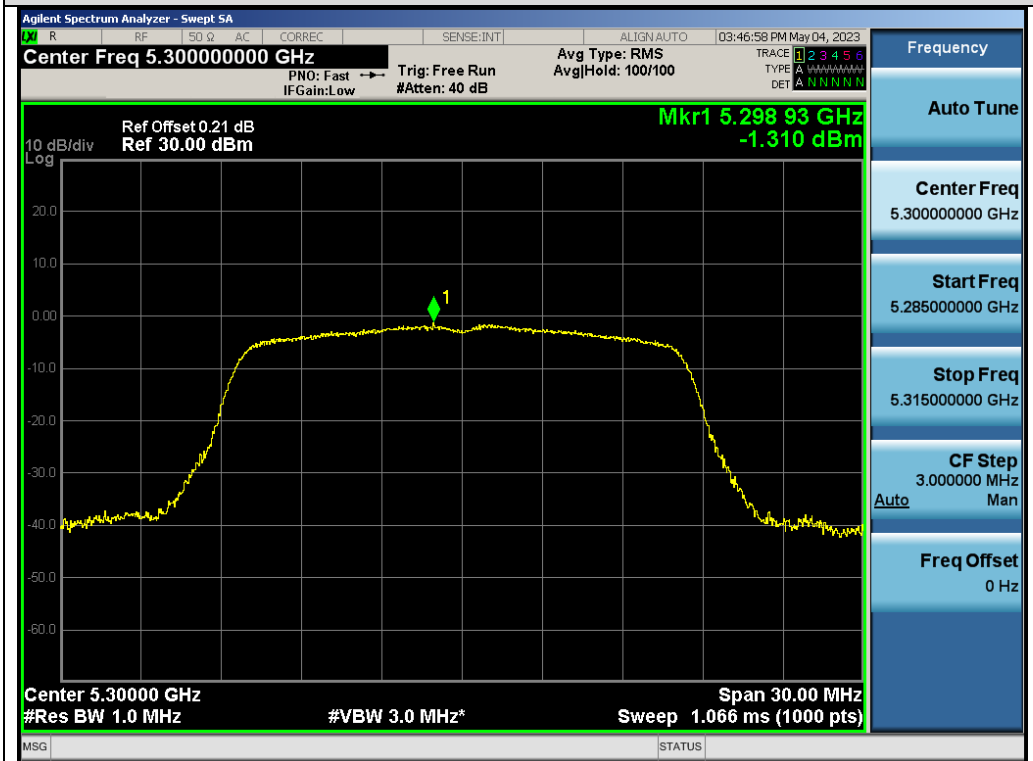

Test\_Graph\_802.11a\_ANT1\_5300\_6Mbps\_PSD

Any report having not been signed by authorized approver, or having been altered without authorization, or having not been stamped by the "Dedicated Testing/Inspection Stamp" is deemed to be invalid. Copying or excerpting portion of, or altering the content of the report is not permitted without the written authorization of AGC. The test results presented in the report apply only to the tested sample. Any objections to report issued by AGC should be submitted to AGC within 15days after the issuance of the test report. Further enquiry of validity or verification of the test report should be addressed to AGC by agc01@agccert.com.

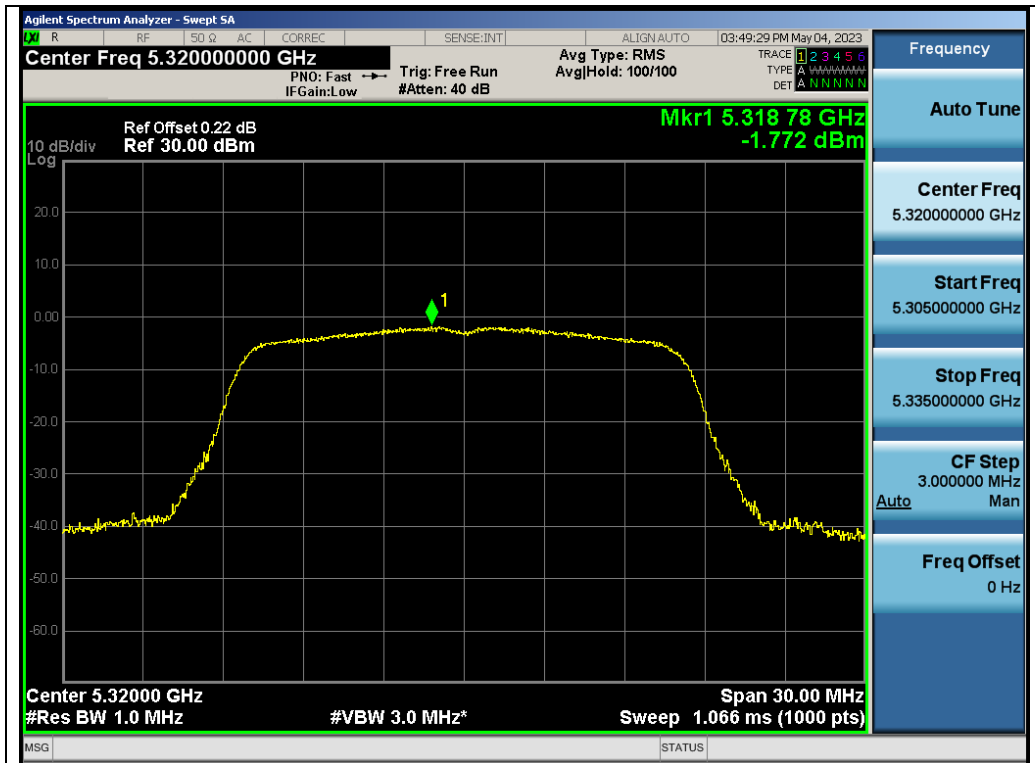

Test\_Graph\_802.11a\_ANT1\_5320\_6Mbps\_PSD

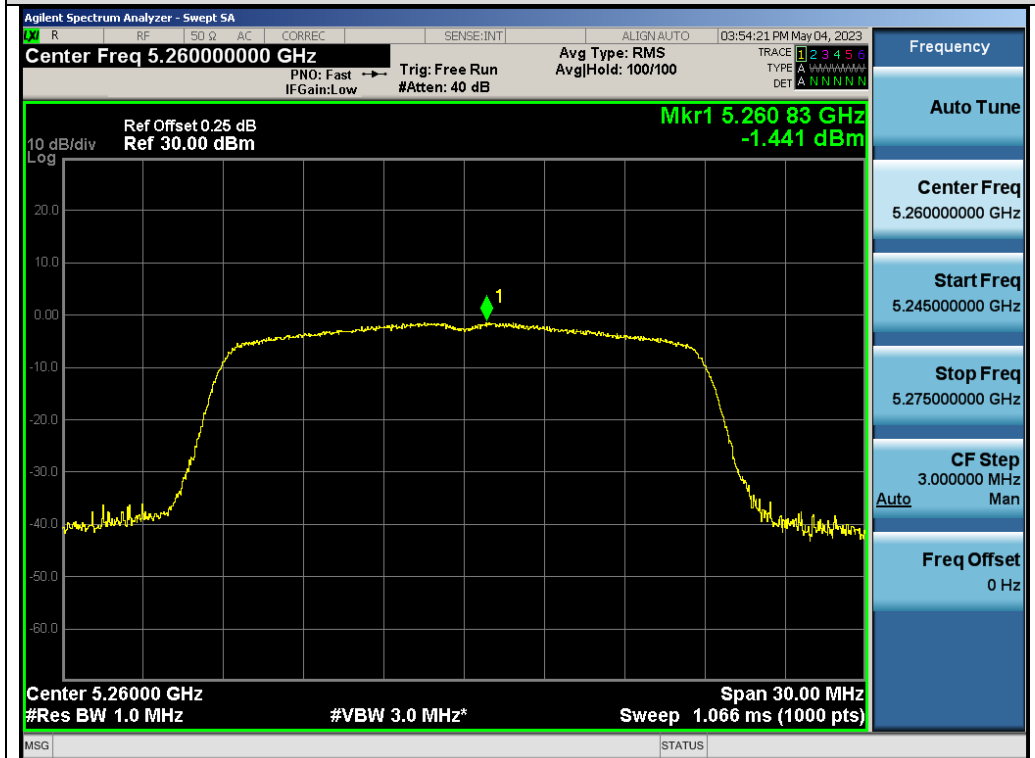

Test\_Graph\_802.11n20\_ANT1\_5260\_MCS0\_PSD

Any report having not been signed by authorized approver, or having been altered without authorization, or having not been stamped by the "Dedicated Testing/Inspection Stamp" is deemed to be invalid. Copying or excerpting portion of, or altering the content of the report is not permitted without the written authorization of AGC. The test results presented in the report apply only to the tested sample. Any objections to report issued by AGC should be submitted to AGC within 15days after the issuance of the test report. Further enquiry of validity or verification of the test report should be addressed to AGC by agc01@agccert.com.

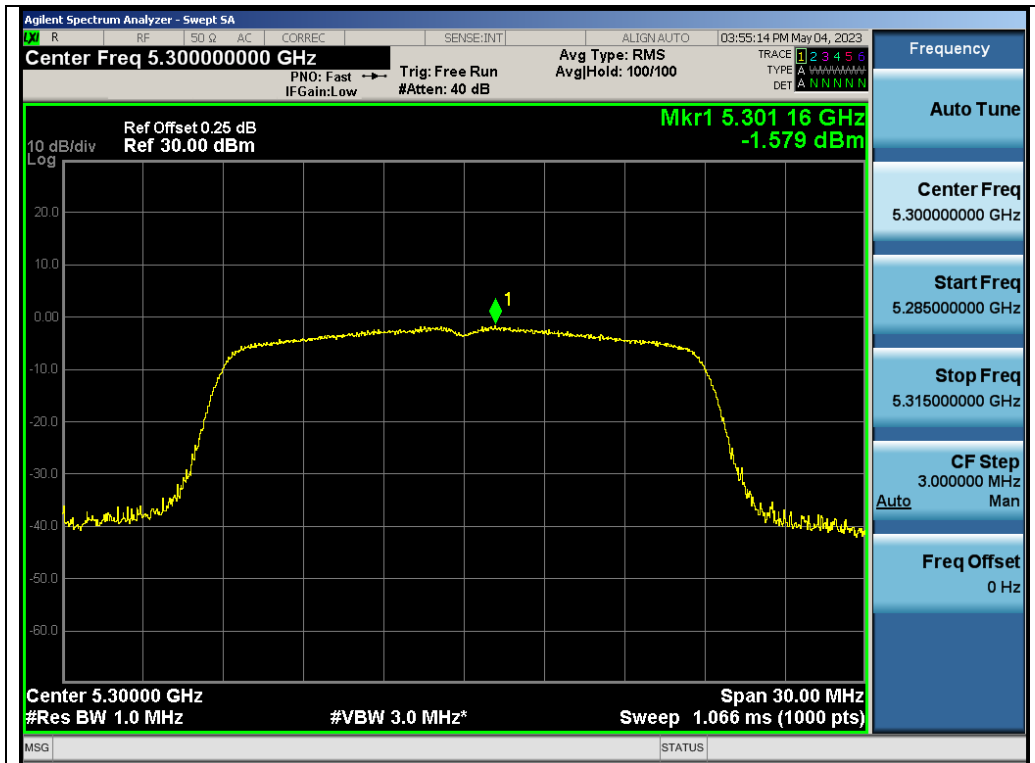

Test\_Graph\_802.11n20\_ANT1\_5300\_MCS0\_PSD

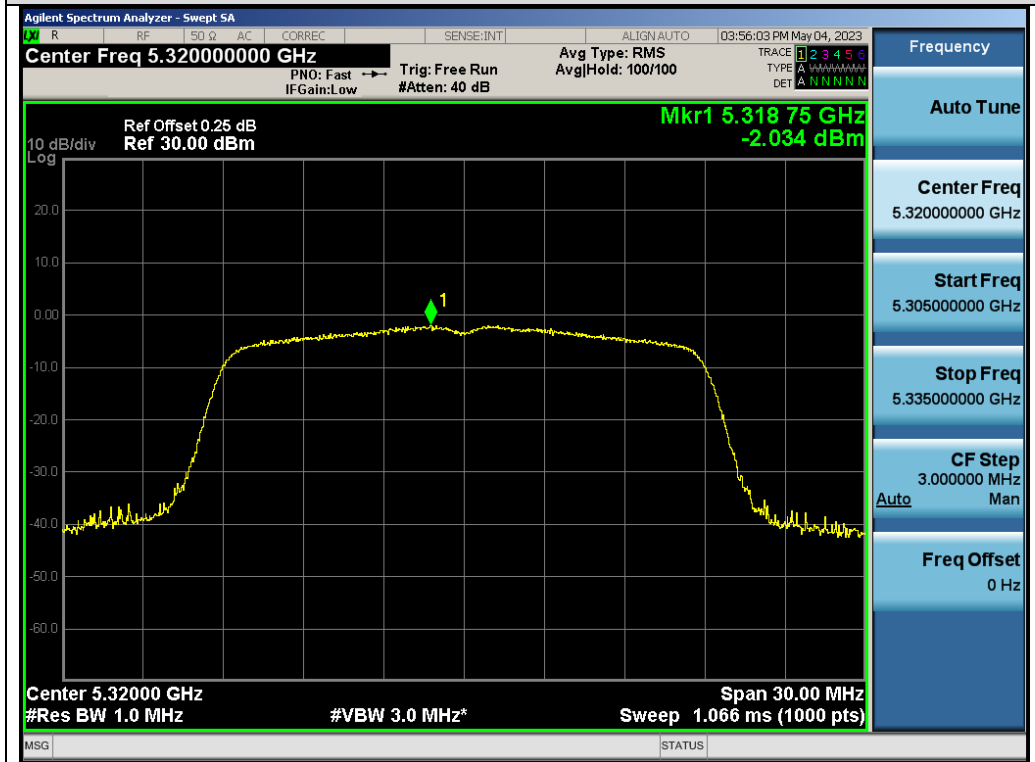

Test\_Graph\_802.11n20\_ANT1\_5320\_MCS0\_PSD

Any report having not been signed by authorized approver, or having been altered without authorization, or having not been stamped by the "Dedicated Testing/Inspection Stamp" is deemed to be invalid. Copying or excerpting portion of, or altering the content of the report is not permitted without the written authorization of AGC. The test results presented in the report apply only to the tested sample. Any objections to report issued by AGC should be submitted to AGC within 15days after the issuance of the test report. Further enquiry of validity or verification of the test report should be addressed to AGC by agc01@agccert.com.

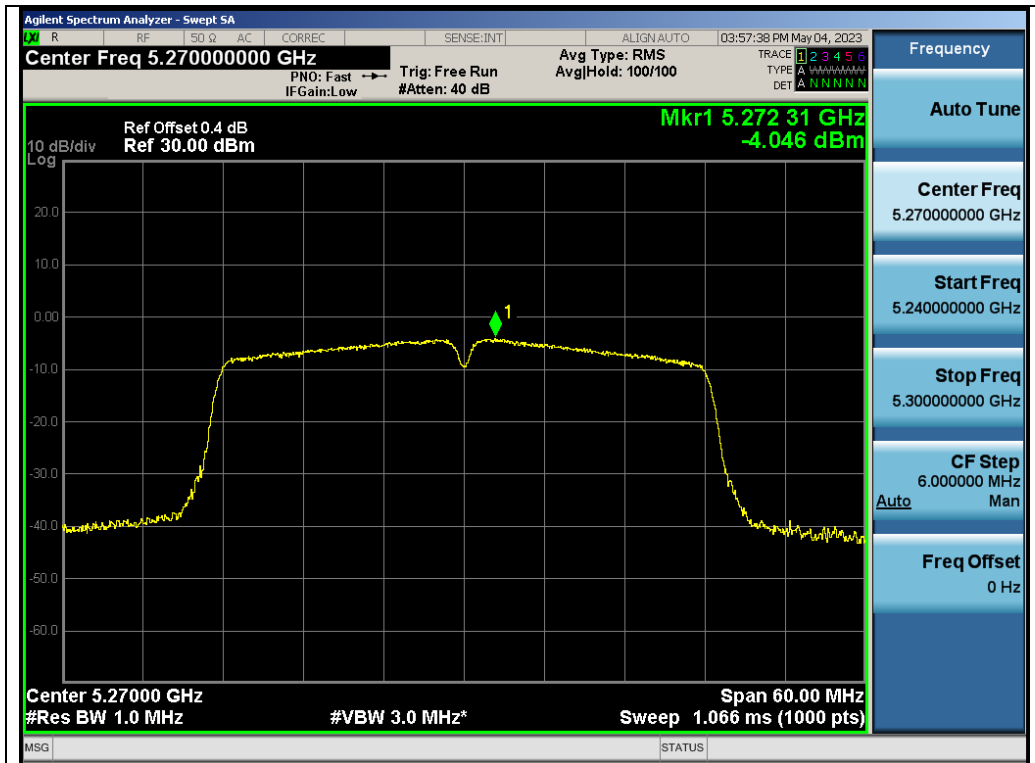

Test\_Graph\_802.11n40\_ANT1\_5270\_MCS0\_PSD

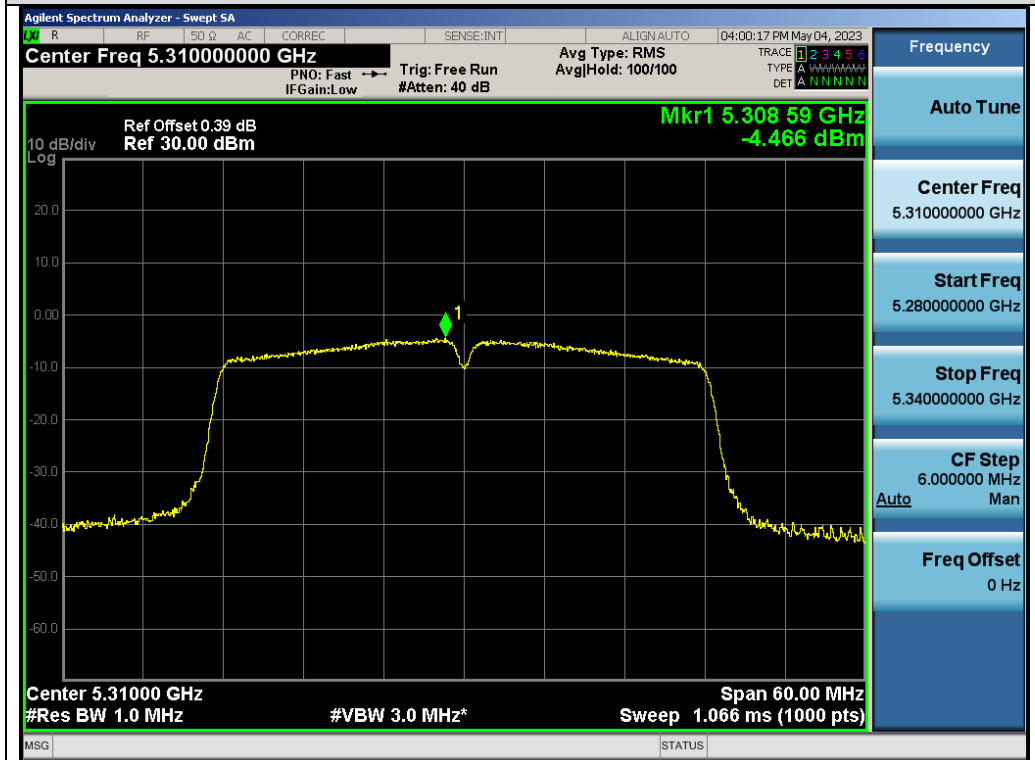

Test\_Graph\_802.11n40\_ANT1\_5310\_MCS0\_PSD

Any report having not been signed by authorized approver, or having been altered without authorization, or having not been stamped by the "Dedicated Testing/Inspection Stamp" is deemed to be invalid. Copying or excerpting portion of, or altering the content of the report is not permitted without the written authorization of AGC. The test results presented in the report apply only to the tested sample. Any objections to report issued by AGC should be submitted to AGC within 15days after the issuance of the test report. Further enquiry of validity or verification of the test report should be addressed to AGC by agc01@agccert.com.

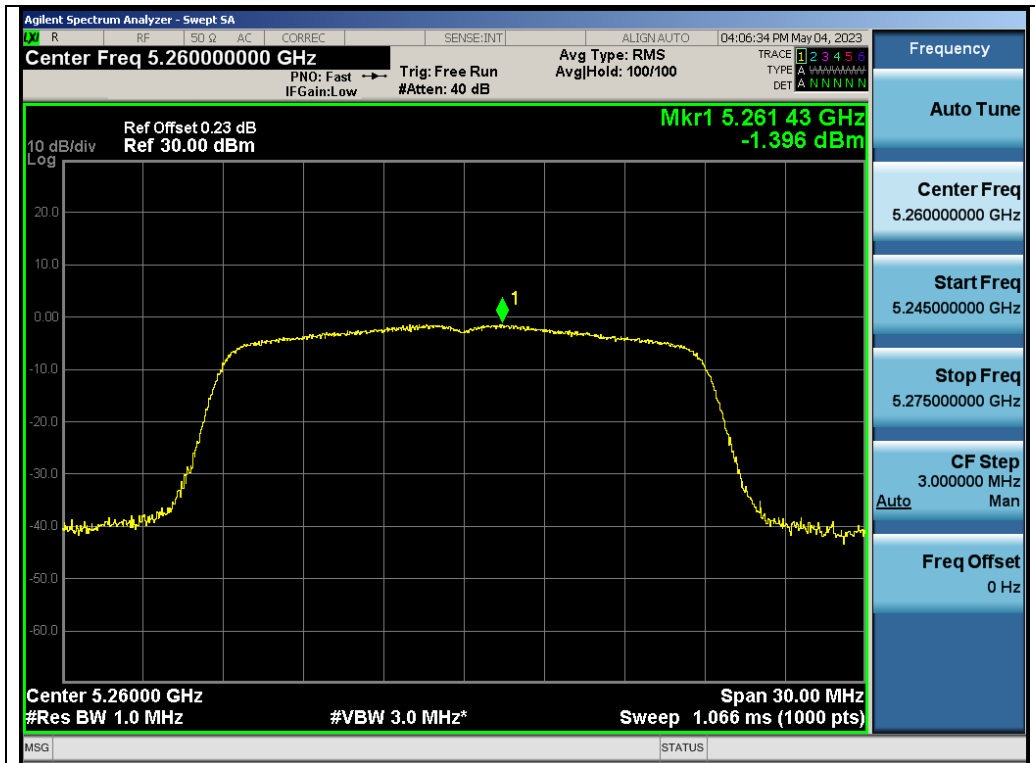

Test\_Graph\_802.11ac20\_ANT1\_5260\_MCS0\_PSD

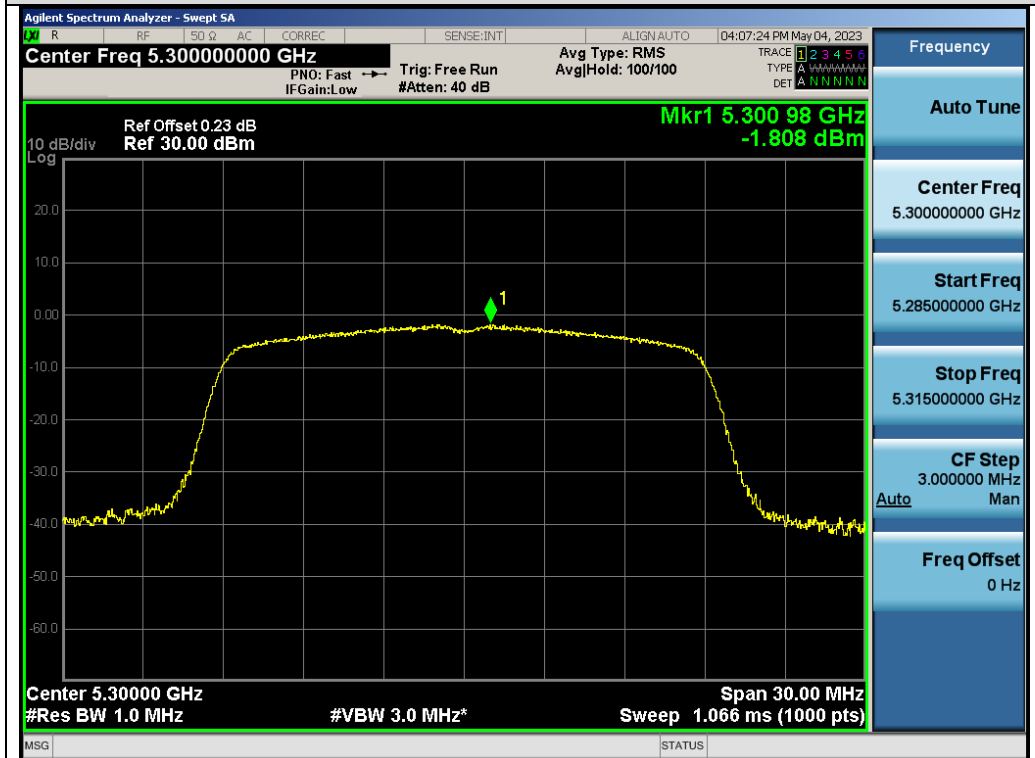

Test\_Graph\_802.11ac20\_ANT1\_5300\_MCS0\_PSD

Any report having not been signed by authorized approver, or having been altered without authorization, or having not been stamped by the "Dedicated Testing/Inspection Stamp" is deemed to be invalid. Copying or excerpting portion of, or altering the content of the report is not permitted without the written authorization of AGC. The test results presented in the report apply only to the tested sample. Any objections to report issued by AGC should be submitted to AGC within 15days after the issuance of the test report. Further enquiry of validity or verification of the test report should be addressed to AGC by agc01@agccert.com.

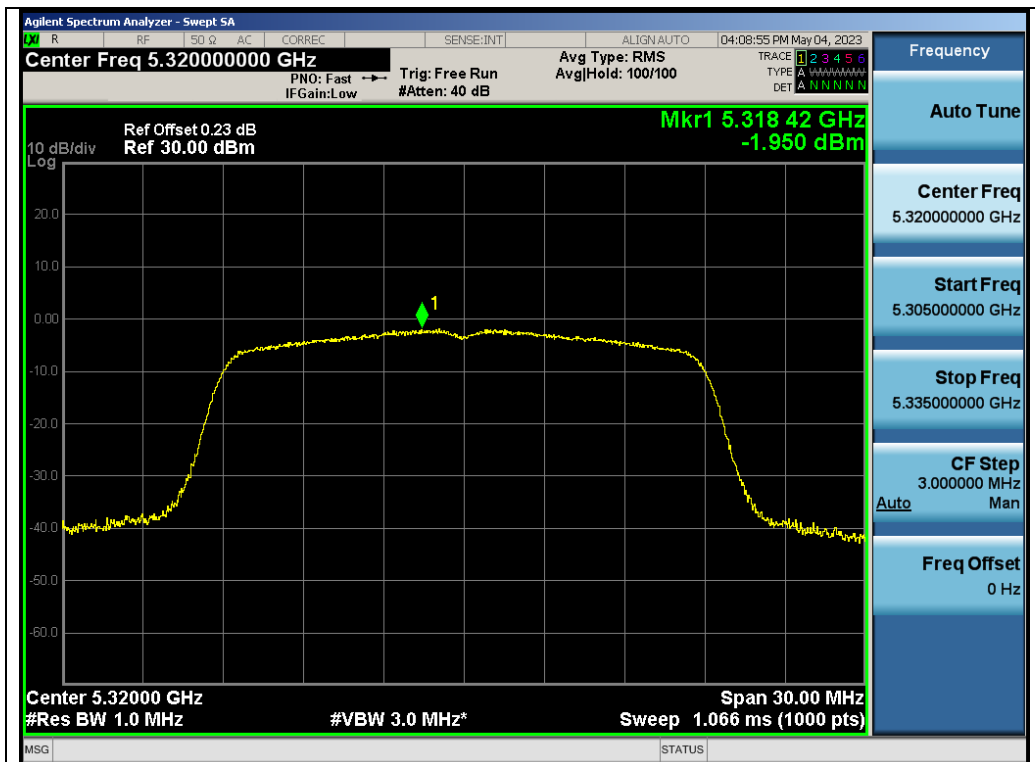

Test\_Graph\_802.11ac20\_ANT1\_5320\_MCS0\_PSD

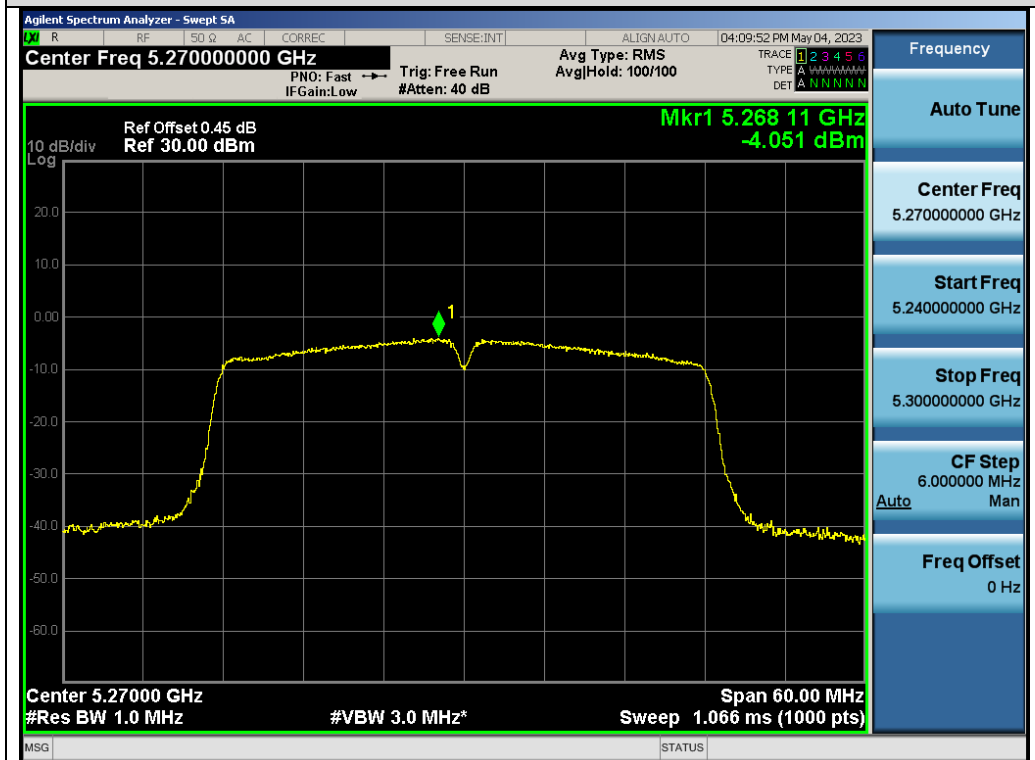

Test\_Graph\_802.11ac40\_ANT1\_5270\_MCS0\_PSD

Any report having not been signed by authorized approver, or having been altered without authorization, or having not been stamped by the "Dedicated Testing/Inspection Stamp" is deemed to be invalid. Copying or excerpting portion of, or altering the content of the report is not permitted without the written authorization of AGC. The test results presented in the report apply only to the tested sample. Any objections to report issued by AGC should be submitted to AGC within 15days after the issuance of the test report. Further enquiry of validity or verification of the test report should be addressed to AGC by agc01@agccert.com.

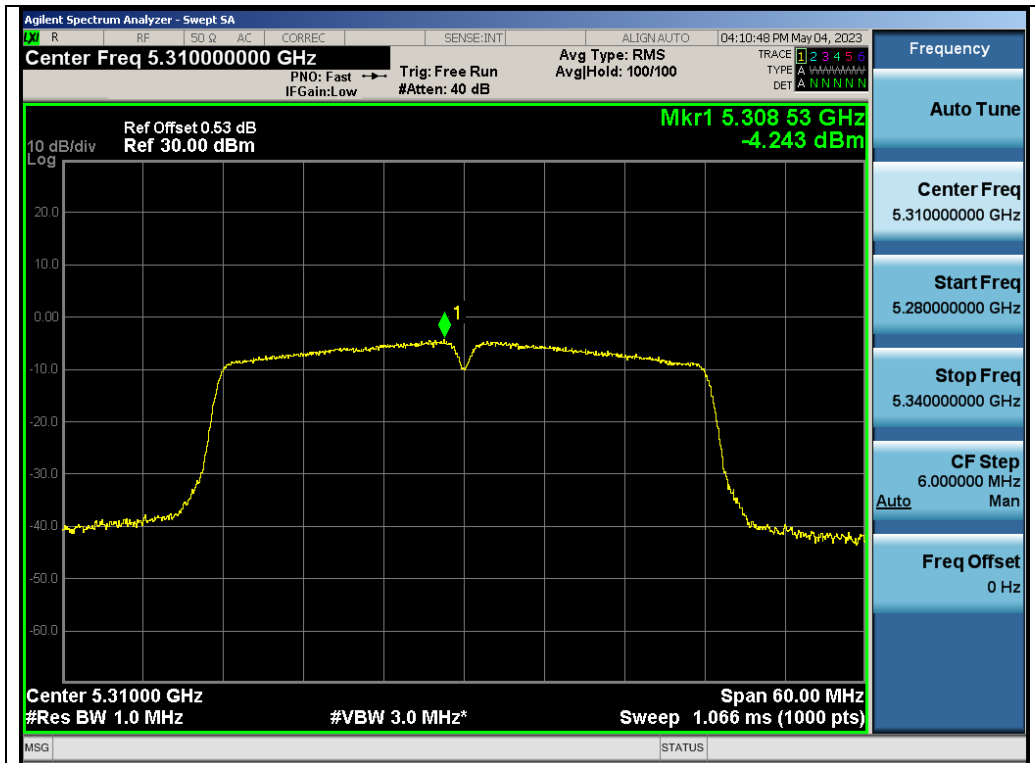

Test\_Graph\_802.11ac40\_ANT1\_5310\_MCS0\_PSD

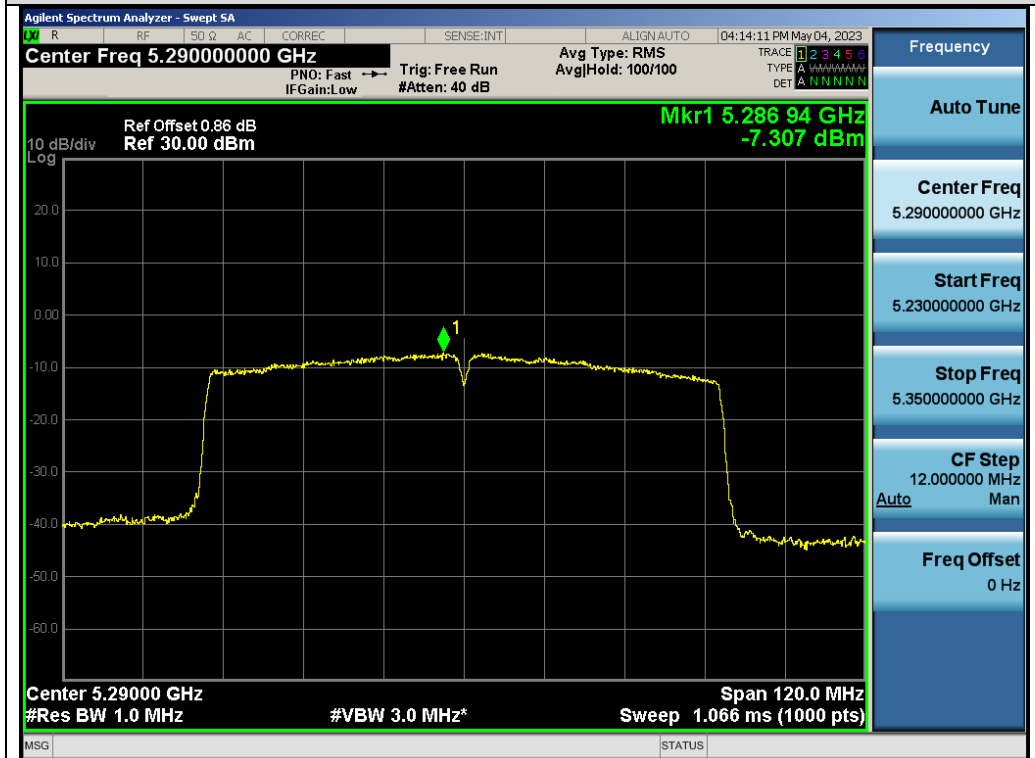

Test\_Graph\_802.11ac80\_ANT1\_5290\_MCS0\_PSD

Any report having not been signed by authorized approver, or having been altered without authorization, or having not been stamped by the "Dedicated Testing/Inspection Stamp" is deemed to be invalid. Copying or excerpting portion of, or altering the content of the report is not permitted without the written authorization of AGC. The test results presented in the report apply only to the tested sample. Any objections to report issued by AGC should be submitted to AGC within 15days after the issuance of the test report. Further enquiry of validity or verification of the test report should be addressed to AGC by agc01@agccert.com.



Test Graphs of Conducted Output Power Spectral Density for band 5.470-5.725 GHz

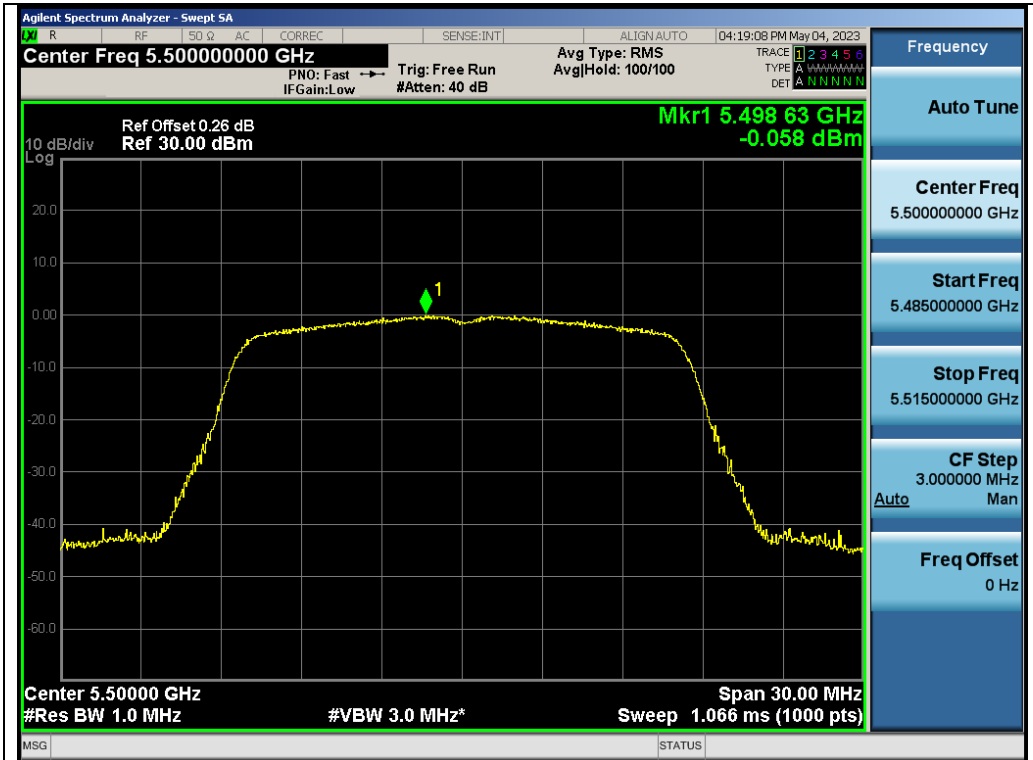

Test\_Graph\_802.11a\_ANT1\_5500\_6Mbps\_PSD

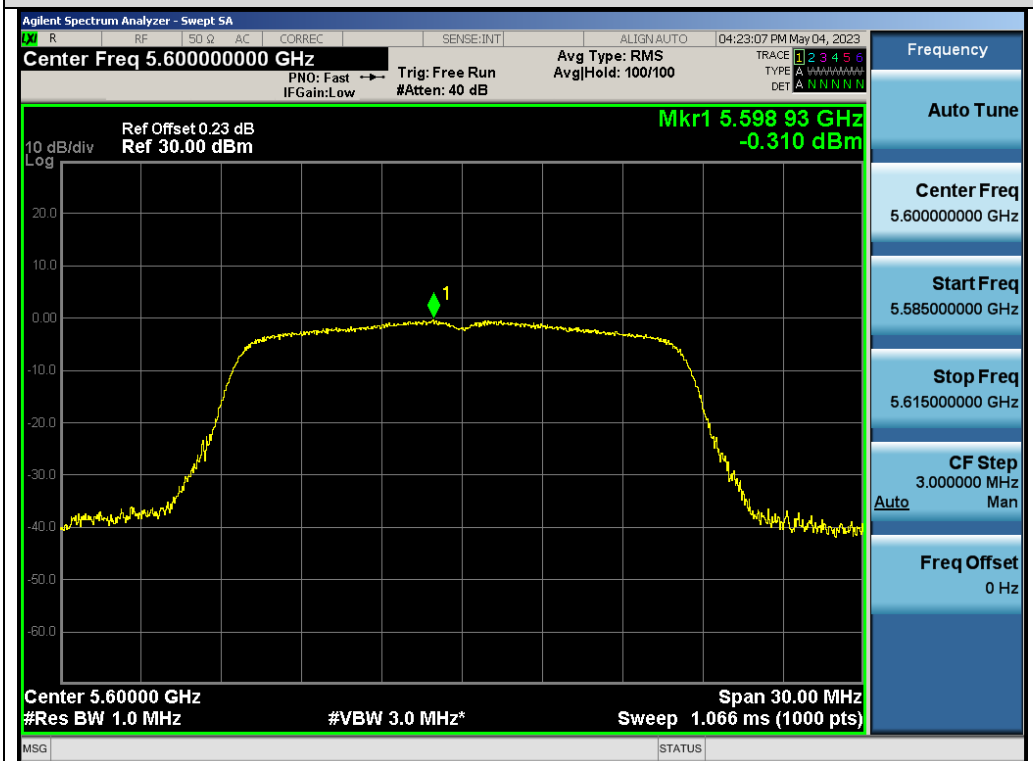

Test\_Graph\_802.11a\_ANT1\_5600\_6Mbps\_PSD

Any report having not been signed by authorized approver, or having been altered without authorization, or having not been stamped by the "Dedicated Testing/Inspection Stamp" is deemed to be invalid. Copying or excerpting portion of, or altering the content of the report is not permitted without the written authorization of AGC. The test results presented in the report apply only to the tested sample. Any objections to report issued by AGC should be submitted to AGC within 15days after the issuance of the test report. Further enquiry of validity or verification of the test report should be addressed to AGC by agc01@agccert.com.



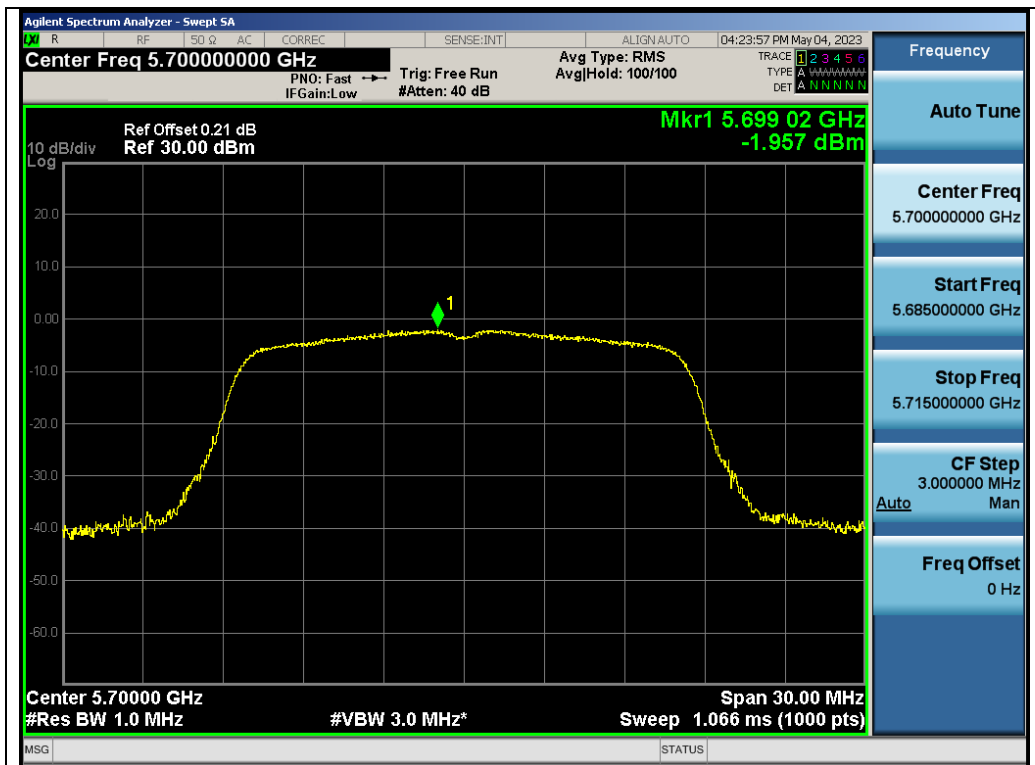

Test\_Graph\_802.11a\_ANT1\_5700\_6Mbps\_PSD

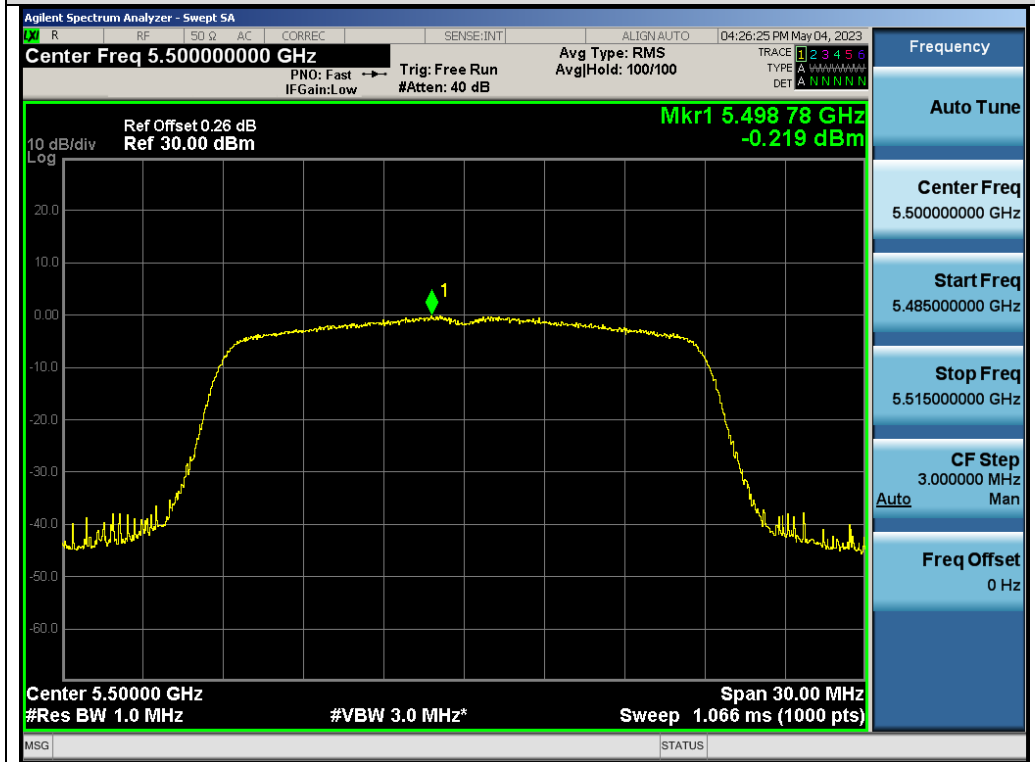

Test\_Graph\_802.11n20\_ANT1\_5500\_MCS0\_PSD

Any report having not been signed by authorized approver, or having been altered without authorization, or having not been stamped by the "Dedicated Testing/Inspection Stamp" is deemed to be invalid. Copying or excerpting portion of, or altering the content of the report is not permitted without the written authorization of AGC. The test results presented in the report apply only to the tested sample. Any objections to report issued by AGC should be submitted to AGC within 15days after the issuance of the test report. Further enquiry of validity or verification of the test report should be addressed to AGC by agc01@agccert.com.

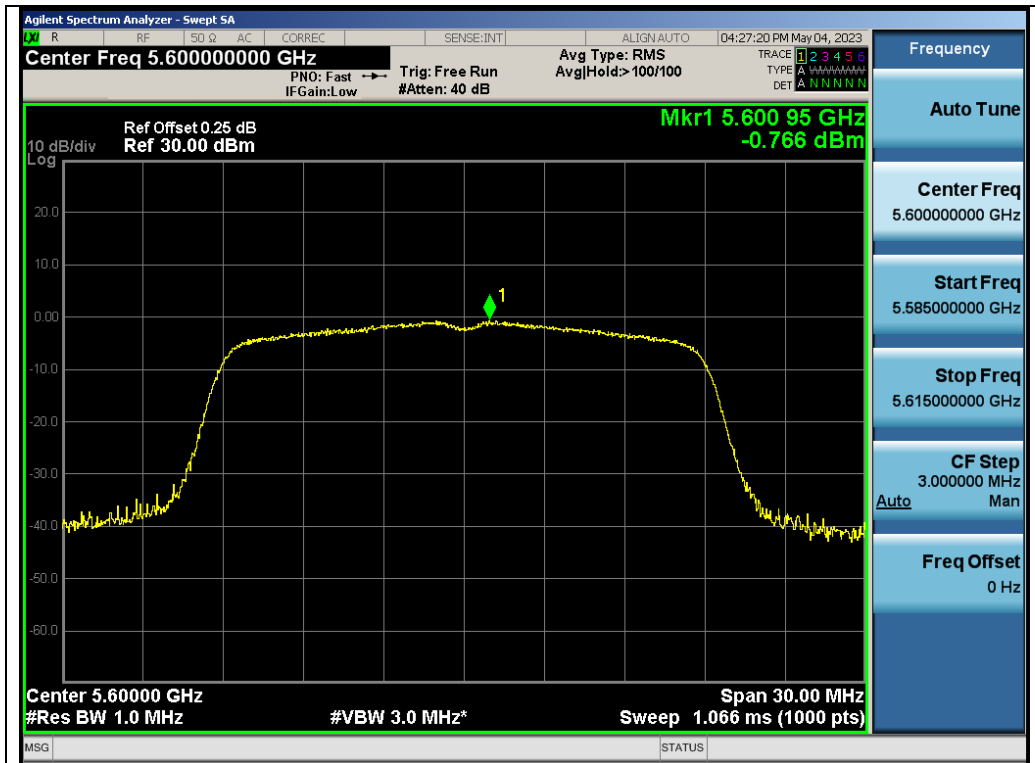

Test\_Graph\_802.11n20\_ANT1\_5600\_MCS0\_PSD

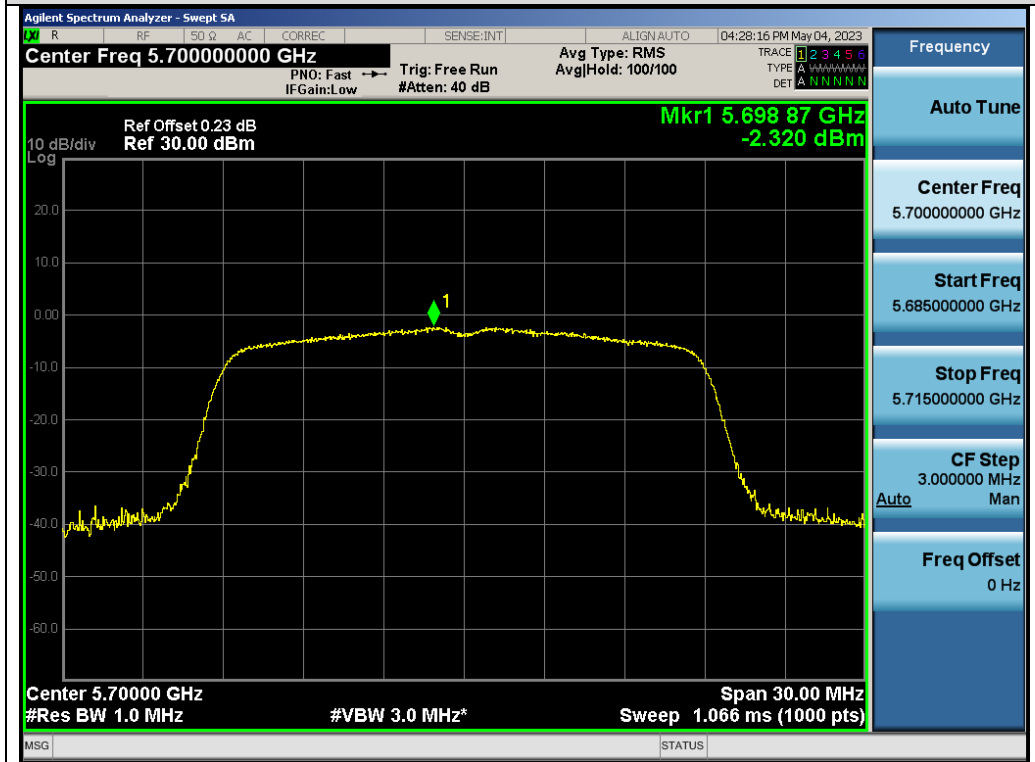

Test\_Graph\_802.11n20\_ANT1\_5700\_MCS0\_PSD

Any report having not been signed by authorized approver, or having been altered without authorization, or having not been stamped by the "Dedicated Testing/Inspection Stamp" is deemed to be invalid. Copying or excerpting portion of, or altering the content of the report is not permitted without the written authorization of AGC. The test results presented in the report apply only to the tested sample. Any objections to report issued by AGC should be submitted to AGC within 15days after the issuance of the test report. Further enquiry of validity or verification of the test report should be addressed to AGC by agc01@agccert.com.

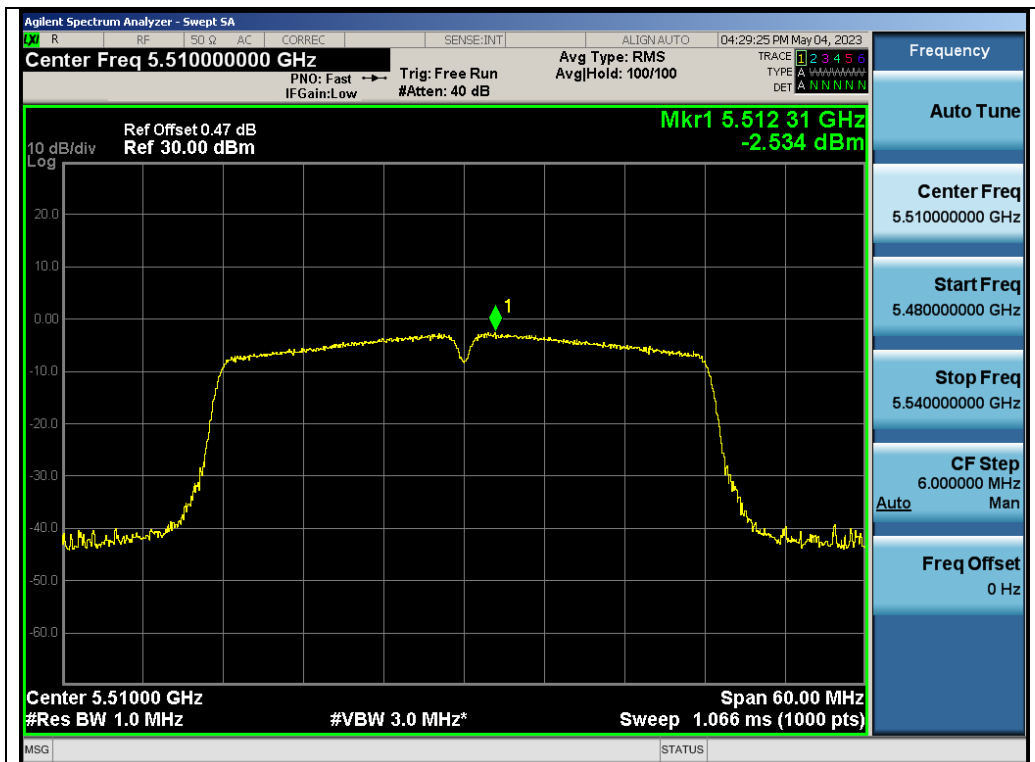

Test\_Graph\_802.11n40\_ANT1\_5510\_MCS0\_PSD

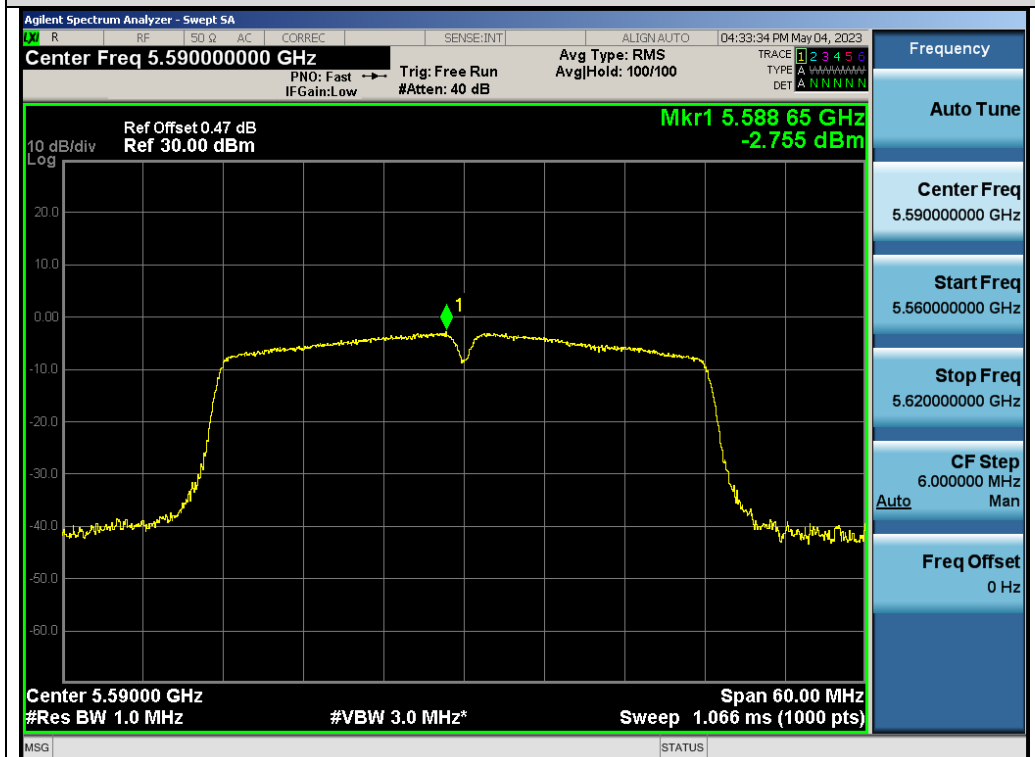

Test\_Graph\_802.11n40\_ANT1\_5590\_MCS0\_PSD

Any report having not been signed by authorized approver, or having been altered without authorization, or having not been stamped by the "Dedicated Testing/Inspection Stamp" is deemed to be invalid. Copying or excerpting portion of, or altering the content of the report is not permitted without the written authorization of AGC. The test results presented in the report apply only to the tested sample. Any objections to report issued by AGC should be submitted to AGC within 15days after the issuance of the test report. Further enquiry of validity or verification of the test report should be addressed to AGC by agc01@agccert.com.

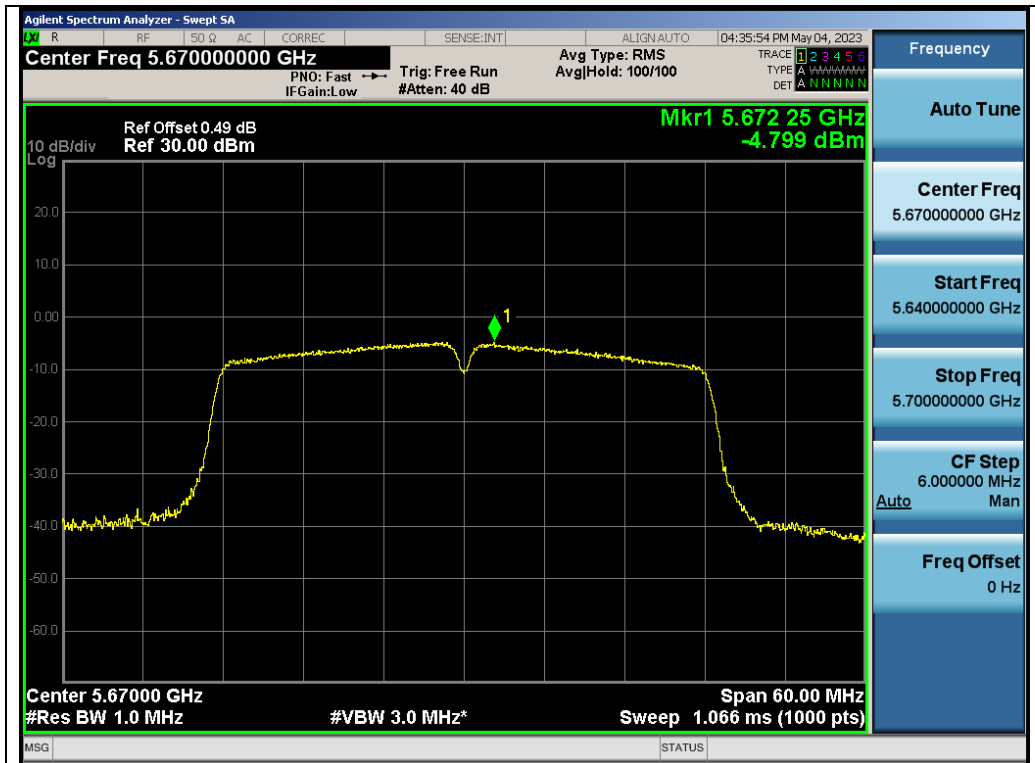

Test\_Graph\_802.11n40\_ANT1\_5670\_MCS0\_PSD

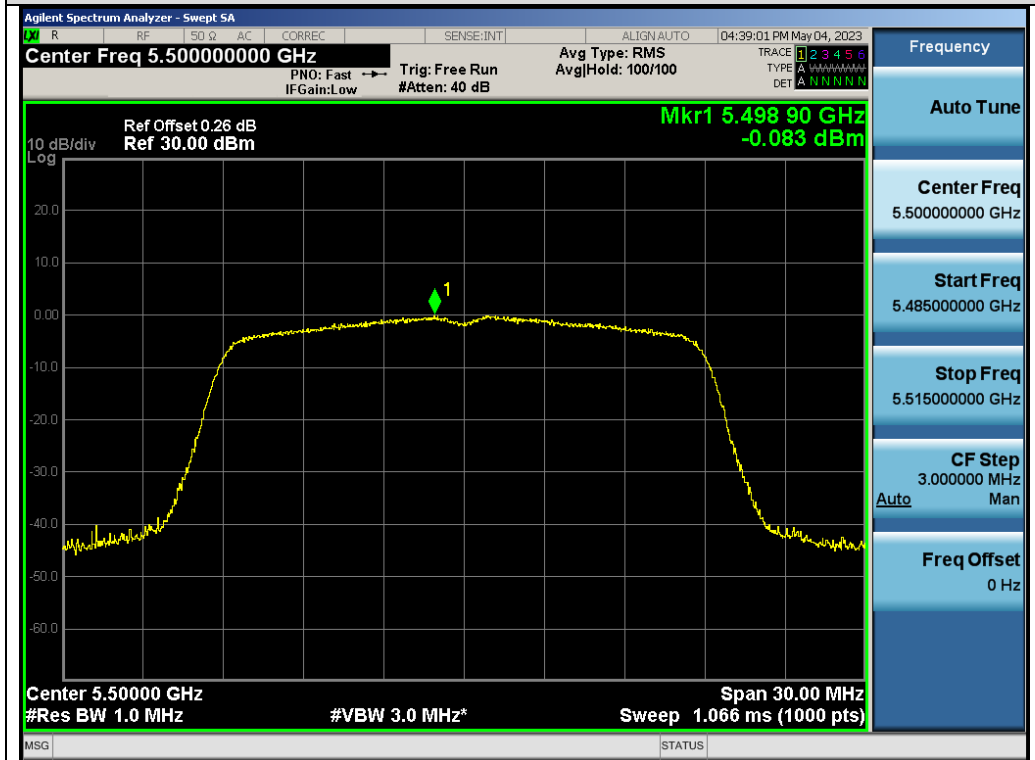

Test\_Graph\_802.11ac20\_ANT1\_5500\_MCS0\_PSD

Any report having not been signed by authorized approver, or having been altered without authorization, or having not been stamped by the "Dedicated Testing/Inspection Stamp" is deemed to be invalid. Copying or excerpting portion of, or altering the content of the report is not permitted without the written authorization of AGC. The test results presented in the report apply only to the tested sample. Any objections to report issued by AGC should be submitted to AGC within 15days after the issuance of the test report. Further enquiry of validity or verification of the test report should be addressed to AGC by agc01@agccert.com.

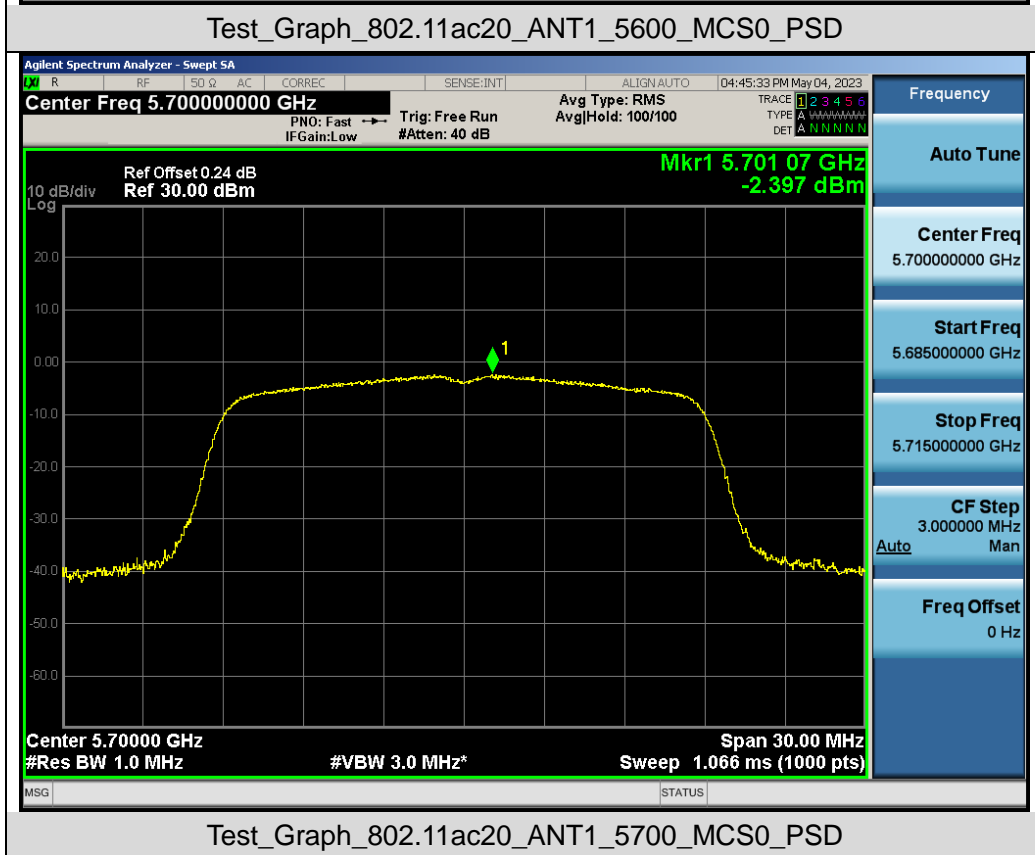
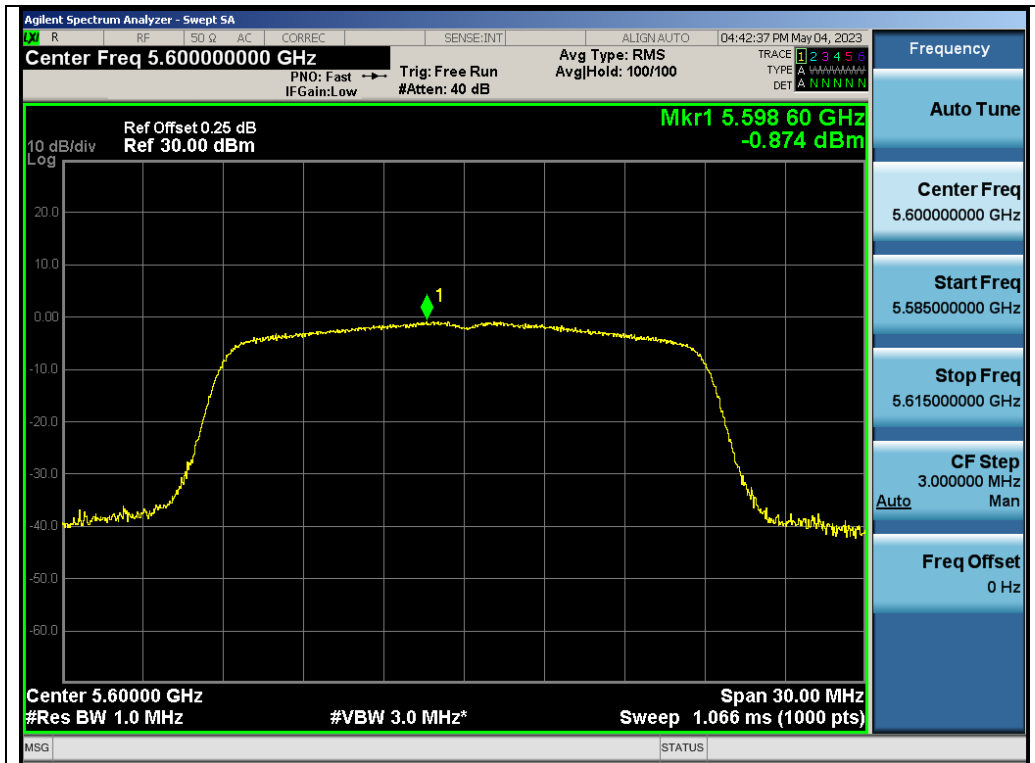

Any report having not been signed by authorized approver, or having been altered without authorization, or having not been stamped by the "Dedicated Testing/Inspection Stamp" is deemed to be invalid. Copying or excerpting portion of, or altering the content of the report is not permitted without the written authorization of AGC. The test results presented in the report apply only to the tested sample. Any objections to report issued by AGC should be submitted to AGC within 15days after the issuance of the test report. Further enquiry of validity or verification of the test report should be addressed to AGC by agc01@agccert.com.

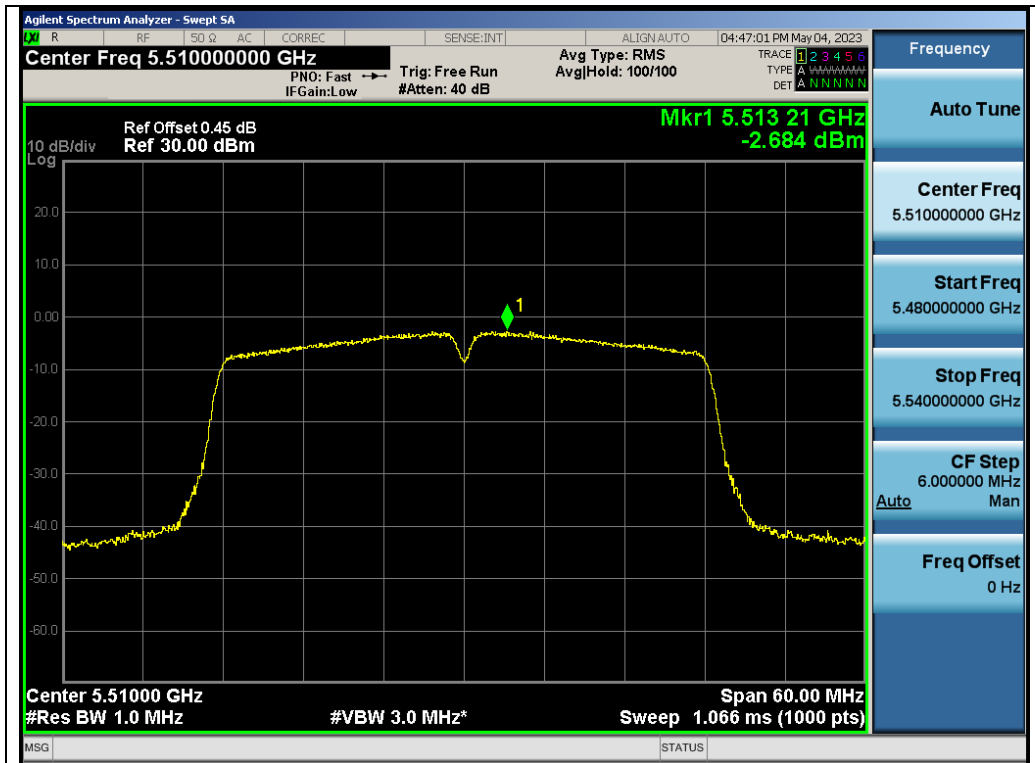

Test\_Graph\_802.11ac40\_ANT1\_5510\_MCS0\_PSD

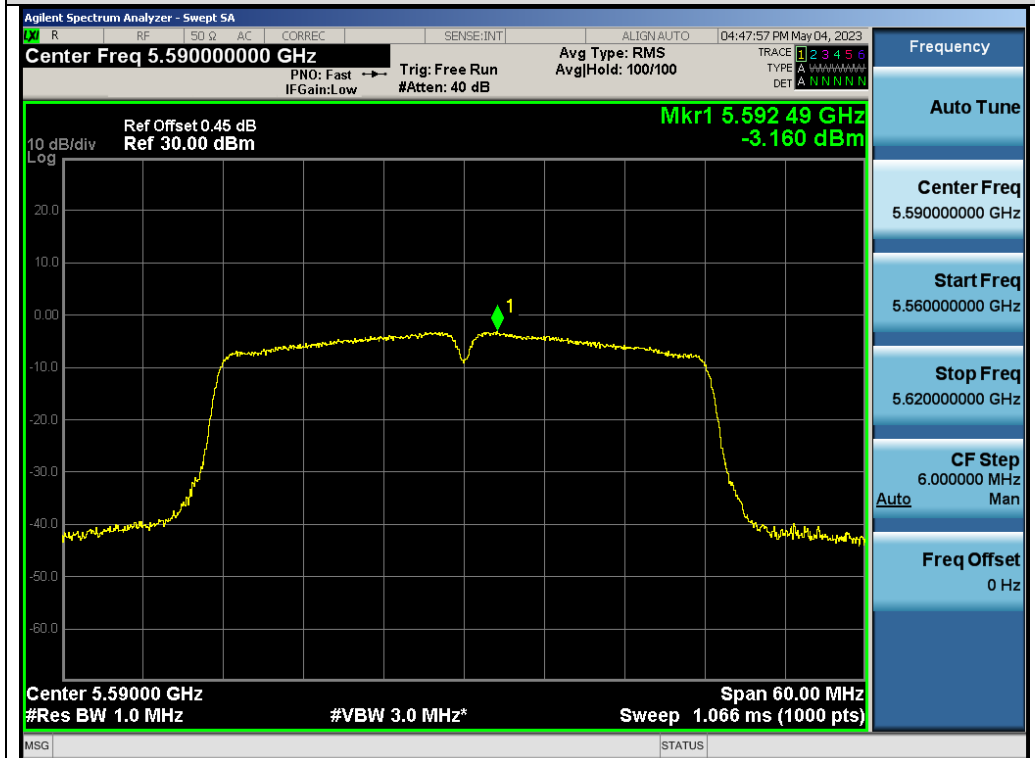

Test\_Graph\_802.11ac40\_ANT1\_5590\_MCS0\_PSD

Any report having not been signed by authorized approver, or having been altered without authorization, or having not been stamped by the "Dedicated Testing/Inspection Stamp" is deemed to be invalid. Copying or excerpting portion of, or altering the content of the report is not permitted without the written authorization of AGC. The test results presented in the report apply only to the tested sample. Any objections to report issued by AGC should be submitted to AGC within 15days after the issuance of the test report. Further enquiry of validity or verification of the test report should be addressed to AGC by agc01@agccert.com.

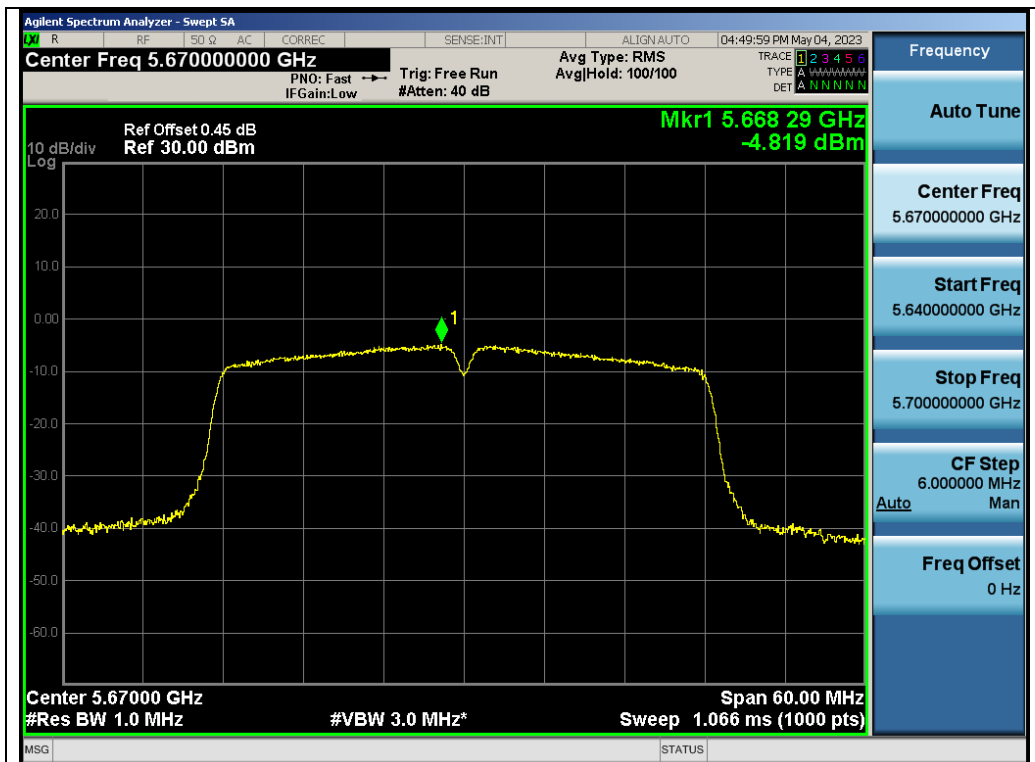

Test\_Graph\_802.11ac40\_ANT1\_5670\_MCS0\_PSD

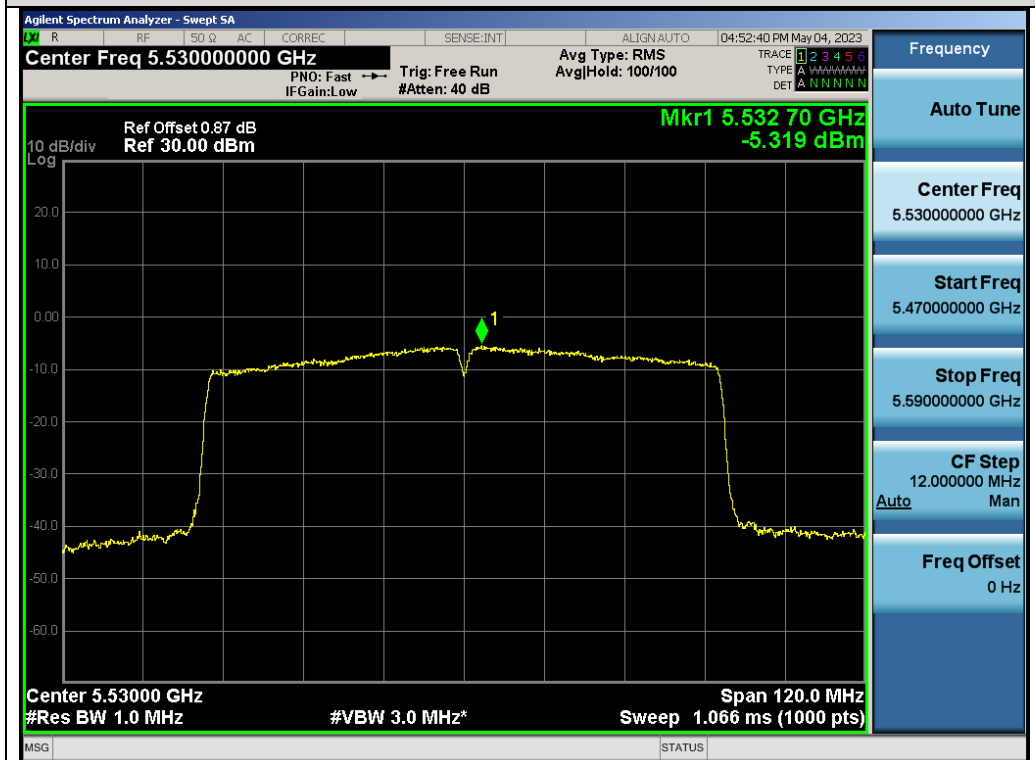

Test\_Graph\_802.11ac80\_ANT1\_5530\_MCS0\_PSD

Any report having not been signed by authorized approver, or having been altered without authorization, or having not been stamped by the "Dedicated Testing/Inspection Stamp" is deemed to be invalid. Copying or excerpting portion of, or altering the content of the report is not permitted without the written authorization of AGC. The test results presented in the report apply only to the tested sample. Any objections to report issued by AGC should be submitted to AGC within 15days after the issuance of the test report. Further enquiry of validity or verification of the test report should be addressed to AGC by agc01@agccert.com.