

## Specification

LED strip and driver	
Model Number: MS-D2BRNPT4	Version number: B01
Voltage: 12V	power: 15W
Warranty: 50000h	Waterproof rate: IP67
control mode: APP	colour: Mirage
LED: 5050	Size: 90cm*120cm

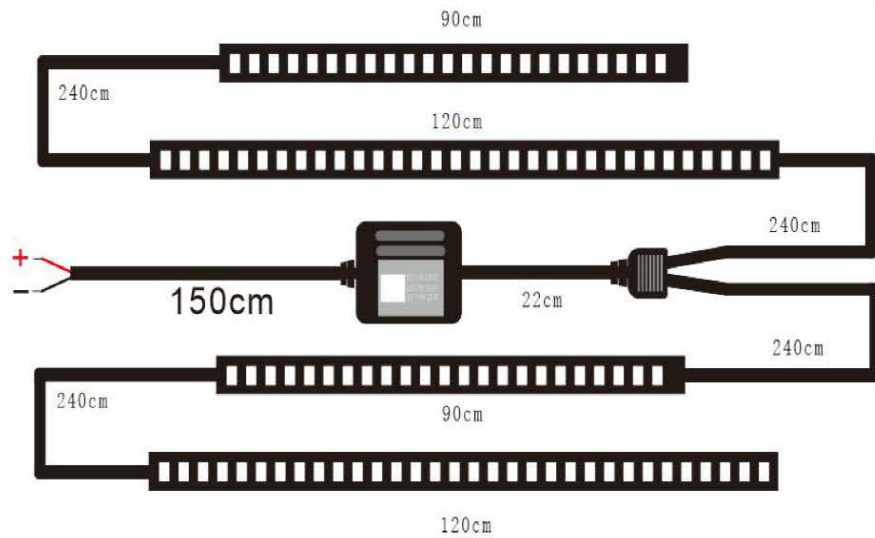

## Installation steps

1. Please test the product for normal use before use before installation. The car chassis is then raised so that the chassis position can be clearly seen.
2. Wipe clean to install the location to avoid dust affect the viscosity of adhesive paper
3. Look for holes that can pass through the strap. If there are no holes, use tools to drill.
4. Rip on the adhesive paper of the lamp bar, stick the lamp strip to the installation position, the long lamp strip is on the left and right sides, and the short lamp strip is in the front and rear positions. Then fasten it with a strap.
5. Install the control box in the car room and find a suitable power supply in the car room.

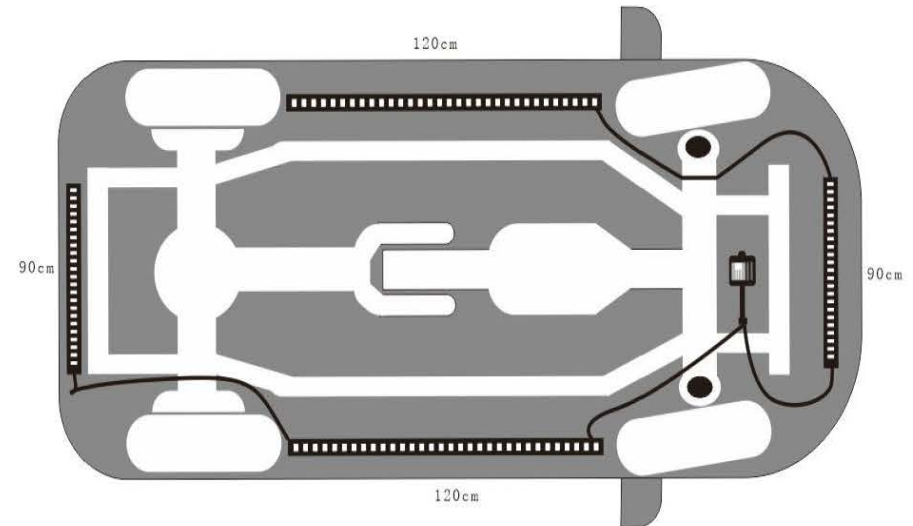

## APP CONTROLLER

1. Please scan the QR code to download the app
2. Use the app menu to control the lights

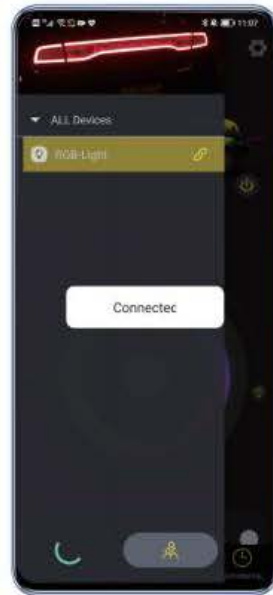

## Car chassis Light



### FCC Statement

This equipment has been tested and found to comply with the limits for a Class B digital device, pursuant to part 15 of the FCC Rules. These limits are designed to provide reasonable protection against harmful interference in a residential installation. This equipment generates, uses and can radiate radio frequency energy and, if not installed and used in accordance with the instructions, may cause harmful interference to radio communications. However, there is no guarantee that interference will not occur in a particular installation. If this equipment does cause harmful interference to radio or television reception, which can be determined by turning the equipment off and on, the user is encouraged to try to correct the interference by one or more of the following measures:

- Reorient or relocate the receiving antenna.
- Increase the separation between the equipment and receiver.
- Connect the equipment into an outlet on a circuit different from that to which the receiver is connected.
- Consult the dealer or an experienced radio/TV technician for help.

Caution: Any changes or modifications to this device not explicitly approved by manufacturer could void your authority to operate this equipment.

This device complies with part 15 of the FCC Rules. Operation is subject to the following two conditions: (1) This device may not cause harmful interference, and (2) this device must accept any interference received, including interference that may cause undesired operation.

### RF Exposure Information

This equipment complies with FCC radiation exposure limits set forth for an uncontrolled environment. This equipment should be installed and operated with minimum distance 20cm between the radiator and your body.