



www.petlibro.com



Dockstream

App Monitoring Automatic Pet Water Fountain

@Libro Corp. All Rights Reserved.

Model: PLWF105

Manufacturer: Shenzhen Libro Technology Co., Ltd.

Address: 12/F, Tower B, GALAXY WORLD, Yabao Road,
Longgang District, Shenzhen, China

JP Importer: 株式会社成洋

Made in China

PLWF105_V1.0

IC: 28987-PLWF105

FCC ID: 2A3DE-PLWF105

CAN ICES-3 (B)/NMB-3(B)



This device complies with Part 15 of the FCC Rules. Operation is subject to the following two conditions: (1) this device may not cause harmful interference, and (2) this device must accept any interference received, including interference that may cause undesired operation.

Model: PLWF105

USER MANUAL

Dockstream App Monitoring Automatic
Pet Water Fountain

Please read this manual before using the product and keep it for future reference. Or open the PETLIBRO app and go to DEVICE SETTINGS > Instructions for the digital manual and instructional video.

CONTENTS

IN THE BOX	01
PRODUCT OVERVIEW	02
GETTING STARTED	05
APP CONTROL	07
SPECIFICATIONS	08
SAFETY INSTRUCTIONS	09
WARRANTY	10
NOTICE	10

IN THE BOX



1 x Automatic
Pet Water Fountain

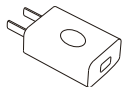

1 x Power Adapter

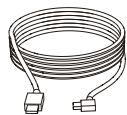

1 x Power Cable



1 x User Manual

PRODUCT OVERVIEW

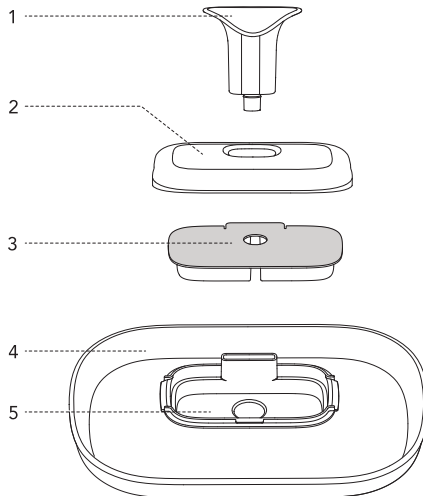

1. Spout
2. Filter Lid
3. Filter

4. Stainless Steel Water Tray
5. Filter Tray

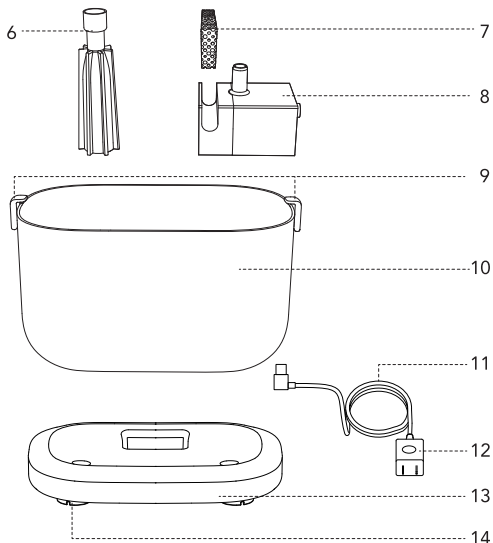

- 6. Water Pipe
- 7. Foam Filter
- 8. Wireless Water Pump
- 9. Snap Lids
- 10. Water Tank

- 11. Power Cable
- 12. Power Adapter
- 13. Tank Base
- 14. Load Cell Sensor

Indicator

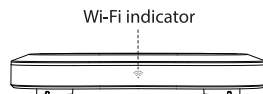

Indicator Status	Device Status
Flashes white once every one second	Network configuration mode
White on	Wi-Fi is connected
Flashes red and white once every half a second	Network connection failed
Flashes red once every one second	Firmware update
Off	The water fountain is powered off

Button

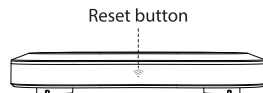

Button	Operation Status
 Reset	After the fountain is connected to Wi-Fi, press and hold for six seconds to reset Wi-Fi settings. And the fountain will enter network configuration mode

GETTING STARTED

Installation

1. Soak the filter in a clean bowl of water for five minutes, then rinse the filter thoroughly with tap water.

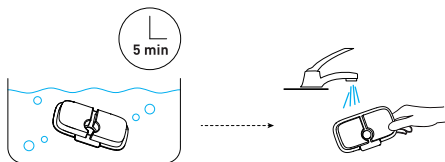

2. Install the water fountain and filter.

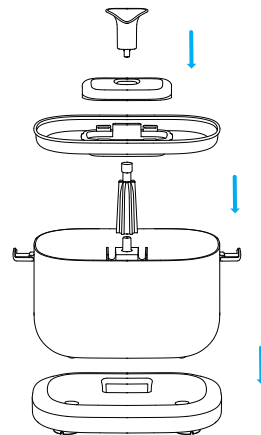
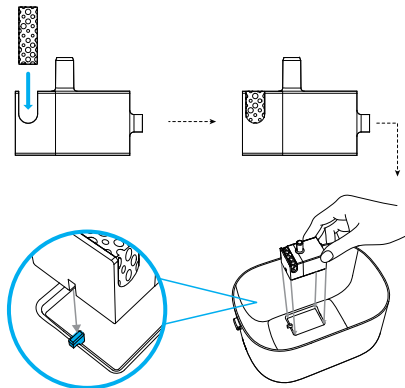

Note: Scan the QR code above to watch the video for product installation and cleaning.

Power on

Connect the fountain to a wall outlet with the power adapter and power cable.

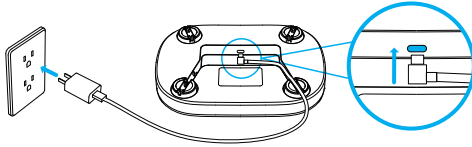

Power off

Unplug the cable from the outlet.

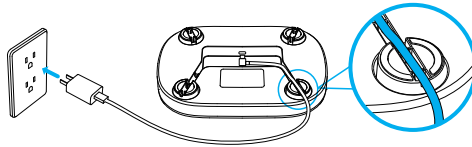

Please route the cable through one of the cable slots on the bottom of the fountain for accurate water level monitoring.

APP CONTROL

1. Download and install the PETLIBRO app.



2. Follow the instructions to configure the network.

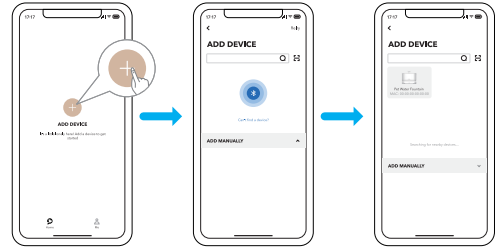

SPECIFICATIONS

Model	PLWF105
Power Adapter	Input: AC 100-240V 50/60Hz Output: DC 5V 1A
Water Tank Capacity	2.5L
Wireless Frequency	2.4GHz
Supported System	Android, iOS
Material	ABS, stainless steel
Dimensions	231 × 191 × 161 mm 9.1 × 7.5 × 6.3 in
Weight	858g / 1.9lb

SAFETY INSTRUCTIONS

- Use the fountain in a dry place.
- Use the fountain on a level surface.
- Dispose of all packaging materials properly. Some items may be packed in plastic bags; these bags could cause suffocation. Keep them away from children and pets.
- Do not use the water fountain with pets that are not able to reach the water tray or with any physical disability.
- Do not immerse the base part in water at any time as it may damage electronic components.
- Do not use the fountain outdoors. Check its operation frequently to be sure it is operating properly.
- Do not disassemble the fountain other than as instructed in this user manual.
- Only use accessories recommended or sold by the manufacturer. The use of accessories not recommended or sold by the manufacturer may cause an unsafe condition.
- Do not modify the fountain.
- Examine the fountain after installation. Do not plug in if there is water on the power cable or plug.
- To avoid tripping, always position the power cable out of the way of foot traffic.
- Do not install or store the fountain where it will be exposed to weather or temperatures below 0°C (32°F).
- Do not use the fountain without adding water first.
- Power off the device when it's not in use.

WARRANTY

- 12-month warranty
- For guidance on product use, please contact our customer service team via email: support@petlibro.com.

NOTICE

FCC statement

This device complies with Part 15 of the FCC Rules. Operation is subject to the following two conditions:

- (1) This device may not cause harmful interference, and.
- (2) This device must accept any interference received, including interference that may cause undesired operation.

Changes or modifications to this unit not expressly approved by the party responsible for compliance could void the user's authority to operate the equipment.

NOTE: This equipment has been tested and found to comply with the limits for a Class B digital device, pursuant to Part 15 of the FCC Rules. These limits are designed to provide reasonable protection against harmful interference in a residential installation. This equipment generates, uses and can radiate radio frequency energy and, if not installed and used in accordance with the instructions, may cause harmful interference to radio communications. However, there is no guarantee that interference will not occur in a particular installation. If this equipment does cause harmful interference to radio or television reception, which can be determined by turning the equipment off and on, the user is encouraged to try to correct the interference by one or more of the following measures:

- Reorient or relocate the receiving antenna.

- Increase the separation between the equipment and receiver.
- Connect the equipment into an outlet on a circuit different from that to which the receiver is connected.
- Consult the dealer or an experienced radio/TV technician for help.

This device and its antenna(s) must not be co-located or operated in conjunction with any other antenna or transmitter.

Radio frequency exposure statement

To maintain compliance with the FCC's RF Exposure Guidelines, this equipment should be installed and operated with a minimum distance of 20cm from your body.