



Smart Harvest  
Instruments

HL100 Light Hotspot Miner

# User Manual

<https://smartharvest.ca>

# Whats in the Box

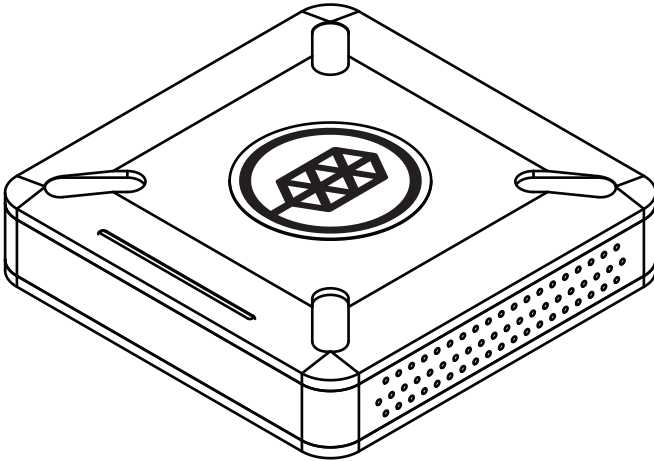

HL100 Light Hotspot Miner

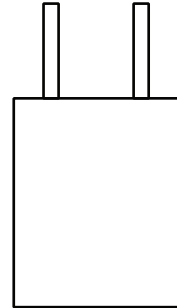

Power Adapter

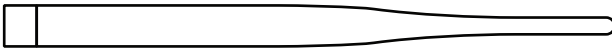

5 dBi Antenna

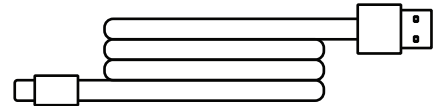

Power Cable

# Know your Light Hotspot Miner

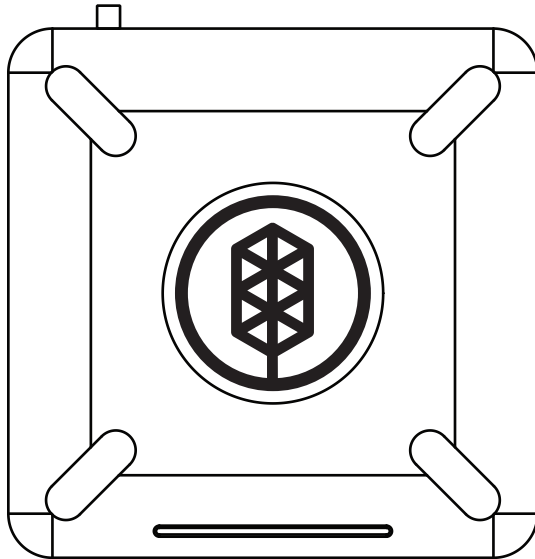

Status LEDs

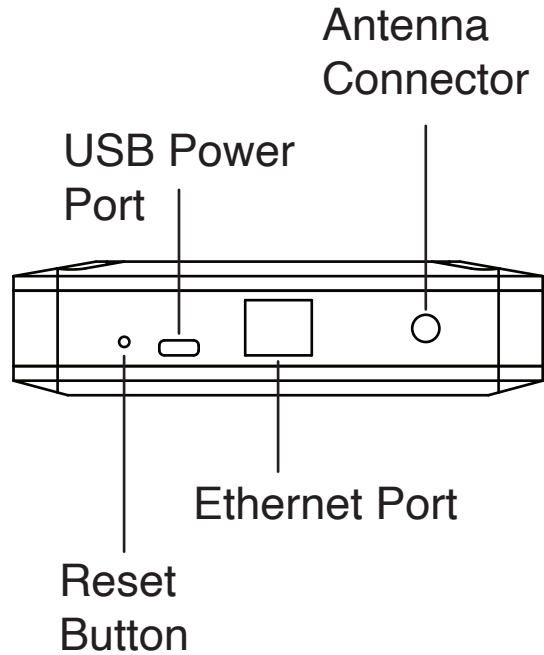

# Set up your Light Hotspot Miner

1. Screw on antenna
2. Connect ethernet port to router
3. Connect power adapter and USB cable to power outlet

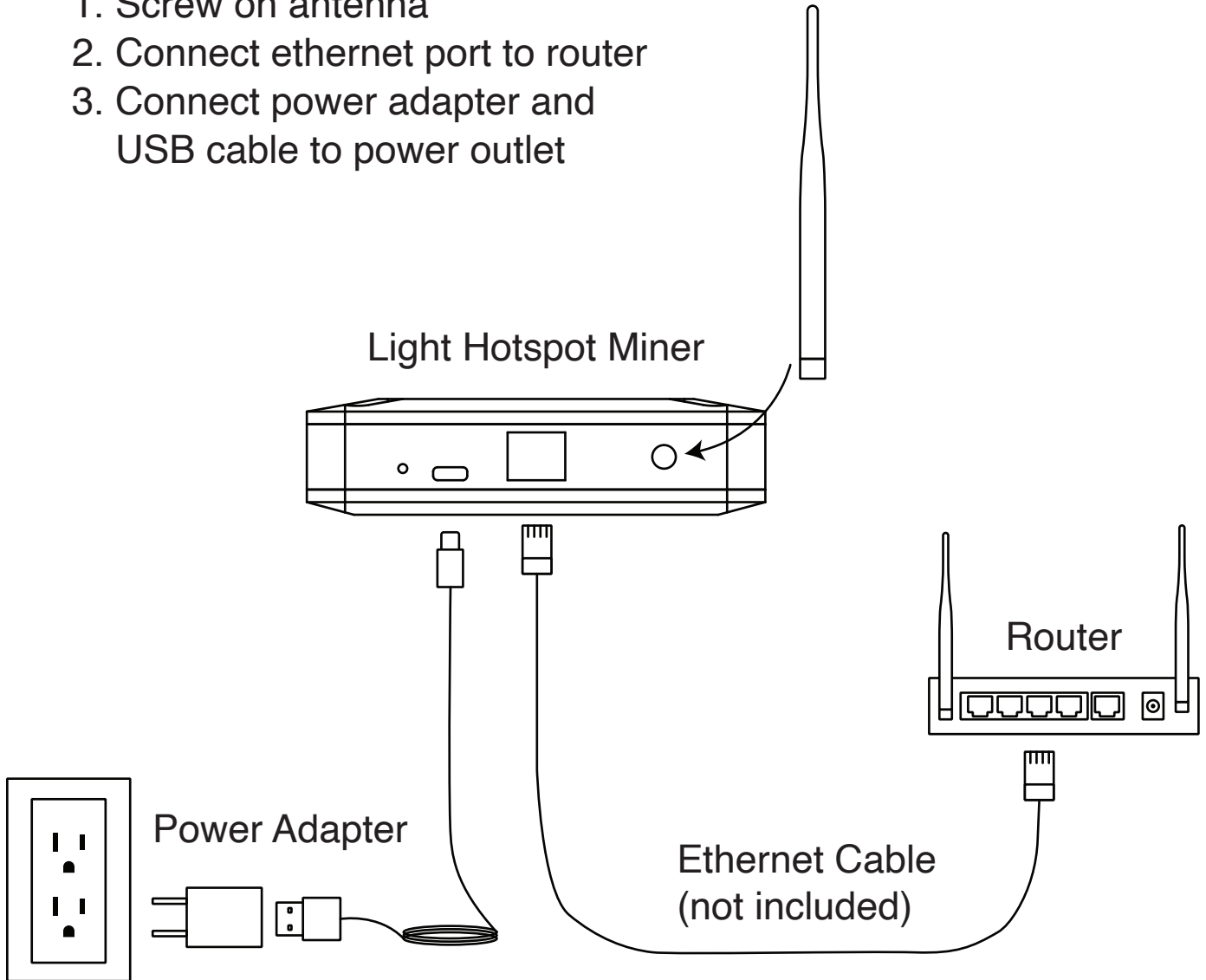

# Onboard your Light Hotspot Miner

- Visit <https://smartharvest.ca/onboard/index.html> and follow the steps to complete the onboarding process
- or scan QR code below



# Hotspot Placement

For best performance:

- **Do:** Place as close to a window as possible
- **Do:** Place raised from floor if possible
  - like a table or a windowsill
- **Don't:** Put into a closet or behind furniture
- **Don't:** Place close to mesh window screens
  - especially if they are metal

Note: your Light Hotspot Miner must be placed at least 20cm (about 8") from other transmitters and people.

# Regulatory Compliance Information

## FCC Compliance

This device complies with part 15 of the FCC Rules. Operation is subject to the following two conditions: (1) This device may not cause harmful interference, and (2) this device must accept any interference received, including interference that may cause undesired operation.

Note: This equipment has been tested and found to comply with the limits for a Class B digital device, pursuant to part 15 of the FCC Rules. These limits are designed to provide reasonable protection against harmful interference in a residential installation.

This equipment generates, uses and can radiate radio frequency energy and, if not installed and used in accordance with the instructions, may cause harmful interference to radio communications. However, there is no guarantee that interference will not occur in a particular installation.

If this equipment does cause harmful interference to radio or television reception, which can be determined by turning the equipment off and on, the user is encouraged to try to correct the interference by one or more of the following measures:

- Reorient or relocate the receiving antenna.
- Increase the separation between the equipment and receiver.
- Connect the equipment into an outlet on a circuit different from that to which the receiver is connected.
- Consult the dealer or an experienced radio/TV technician for help.

Caution: changes or modifications not expressly authorized by Smart Harvest Instruments could void the wireless compliance and your authority to operate this product.

This equipment complies with FCC radiation exposure limits set forth for an uncontrolled environment under the following conditions:

1. This equipment should be installed and operated such that a minimum separation distance of 20cm is maintained between the radiator (antenna) and user's/nearby person's body at all times.
2. This transmitter must not be co-located or operating in conjunction with any other antenna or transmitter.

# Limited Warranty

This product comes with a 1-year limited warranty that is valid only if product was purchased from Smart Harvest Instruments official stores or Smart Harvest Instruments authorized resellers.

Learn more:

<https://smartharvest.ca/warranty-and-return/index.html>



**FCC Warning Statement**

Changes or modifications not expressly approved by the party responsible for compliance could void the user's authority to operate the equipment. This equipment has been tested and found to comply with the limits for a Class B digital device, pursuant to Part 15 of the FCC Rules. These limits are designed to provide reasonable protection against harmful interference in a residential installation. This equipment generates uses and can radiate radio frequency energy and, if not installed and used in accordance with the instructions, may cause harmful interference to radio communications. However, there is no guarantee that interference will not occur in a particular installation. If this equipment does cause harmful interference to radio or television reception, which can be determined by turning the equipment off and on, the user is encouraged to try to correct the interference by one or more of the following measures:

- Reorient or relocate the receiving antenna.
- Increase the separation between the equipment and receiver.
- Connect the equipment into an outlet on a circuit different from that to which the receiver is connected.
- Consult the dealer or an experienced radio/TV technician for help.

**FCC Radiation Exposure Statement**

The antennas used for this transmitter must be installed to provide a separation distance of at least 20 cm from all persons and must not be co-located for operating in conjunction with any other antenna or transmitter.