



TEST REPORT

Test Report No. : UL-RPT-RP-14086589-1316-FCC

Applicant : iSens Electrónica, Lda.
Model No. : iLogger Case 4A
FCC ID : 2A350-ILOGGERCASE
Technology : RFID 13.56 MHz
Test Standard(s) : FCC Parts 15.207, 15.209(a) & 15.225

For details of applied tests refer to test result summary

1. This test report shall not be reproduced in full or partial, without the written approval of UL International Germany GmbH.
2. The results in this report apply only to the sample tested.
3. The test results in this report are traceable to the national or international standards.
4. **Test Report Version 1.1 supersede Version 1.0 with immediate effect**
Test Report No. UL-RPT-RP-14086589-1316-FCC Version 1.1, Issue Date 14 MARCH 2022 replaces
Test Report No. UL-RPT-RP-14086589-1316-FCC Version 1.0, Issue Date 02 MARCH 2022, which is no longer valid.
5. Result of the tested sample: **PASS**

Prepared by: Sercan, Usta
Title: Laboratory Engineer
Date: 14 March 2022

Approved by: Ajit, Phadtare
Title: Lead Test Engineer
Date: 14 March 2022



Deutsche
Akkreditierungsstelle
D-PL-19381-02-00

This laboratory is accredited by DAkkS.
The tests reported herein have been performed in
accordance with its' terms of accreditation.

This page has been left intentionally blank.

Table of Contents

1. Customer Information.....4
 1.1. Applicant Information 4
 1.2. Manufacturer Information 4

2. Summary of Testing.....5
 2.1. General Information 5
 Applied Standards 5
 Location 5
 Date information 5
 2.2. Summary of Test Results 6
 2.3. Methods and Procedures 6
 2.4. Deviations from the Test Specification 6

3. Equipment Under Test (EUT)7
 3.1. Identification of Equipment Under Test (EUT) 7
 3.2. Description of EUT 7
 3.3. Modifications Incorporated in the EUT 7
 3.4. Additional Information Related to Testing 8
 3.5. Support Equipment 8
 A. Support Equipment (In-house) 8
 B. Support Equipment (Manufacturer supplied) 8

4. Operation and Monitoring of the EUT during Testing9
 4.1. Operating Modes 9
 4.2. Configuration and Peripherals 9

5. Measurements, Examinations and Derived Results10
 5.1. General Comments 10
 5.2. Test Results 11
 5.2.1. Transmitter 20 dB Bandwidth 11
 5.2.2. Transmitter Fundamental Field Strength & Spectrum Mask 14
 5.2.3. Transmitter Radiated Spurious Emissions 18
 5.2.4. Transmitter Frequency Stability (Temperature & Voltage Variation) 23

6. Measurement Uncertainty27

7. Used equipment28

8. Open-Area-Test Site comparison.....29

9. Report Revision History33

1. Customer Information

1.1.Applicant Information

Company Name:	iSens Electrónica, Lda.
Company Address:	Rua de Orlando Ribeiro no 78 4465-591 Leça do Balio, Portugal
Company Phone No.:	+351 220 198 410
Company E-Mail:	info@maksense.com
Contact Person:	André Toga
Contact E-Mail Address:	Andre.toga@maksense.com
Contact Phone No.:	+351 912 575 221

1.2.Manufacturer Information

Company Name:	iSens Electrónica, Lda.
Company Address:	Rua de Orlando Ribeiro no 78 4465-591 Leça do Balio, Portugal
Company Phone No.:	+351 220 198 410
Company E-Mail:	info@maksense.com
Contact Person:	André Toga
Contact E-Mail Address:	Andre.toga@maksense.com
Contact Phone No.:	+351 912 575 221

2. Summary of Testing

2.1. General Information

Applied Standards

Specification Reference:	47CFR15.225
Specification Title:	Code of Federal Regulations Volume 47 (Telecommunications): Part 15 Subpart C (Radio Frequency Devices) - Section 15.225
Specification Reference:	47CFR15.207 and 47CFR15.209
Specification Title:	Code of Federal Regulations Volume 47 (Telecommunications): Part 15 Subpart C (Intentional Radiators) - Sections 15.207 and 15.209

Location

Location of Testing:	UL International Germany GmbH Hedelfinger Str. 61 70327 Stuttgart Germany
Test Firm Registration:	399704

Date information

Order Date:	09 November 2021
EUT arrived:	23 December 2021
Test Dates:	05 January 2022 to 01 March 2022
EUT returned:	-/-

2.2. Summary of Test Results

Clause	Measurement	Complied	Did not comply	Not performed	Not applicable
Part 15.207	Transmitter AC Conducted Emissions ⁽¹⁾	<input type="checkbox"/>	<input type="checkbox"/>	<input type="checkbox"/>	<input checked="" type="checkbox"/>
Part 15.215(c)	Transmitter 20 dB Bandwidth	<input checked="" type="checkbox"/>	<input type="checkbox"/>	<input type="checkbox"/>	<input type="checkbox"/>
Part 15.225(a)(b)(c)(d)	Transmitter Fundamental Field Strength & Spectrum Mask	<input checked="" type="checkbox"/>	<input type="checkbox"/>	<input type="checkbox"/>	<input type="checkbox"/>
Part 15.209(a)/ 15.225(d)	Transmitter Radiated Emissions	<input checked="" type="checkbox"/>	<input type="checkbox"/>	<input type="checkbox"/>	<input type="checkbox"/>
Part 15.225(e)	Transmitter Frequency Stability (Temperature & Voltage Variation)	<input checked="" type="checkbox"/>	<input type="checkbox"/>	<input type="checkbox"/>	<input type="checkbox"/>

Note(s):

1. The EUT is operating with non-rechargeable alkaline battery.

2.3. Methods and Procedures

Reference:	ANSI C63.4-2014
Title:	American National Standard for Methods of Measurement of Radio-Noise Emissions from Low-Voltage Electrical and Electronic Equipment in the Range of 9 kHz to 40 GHz.
Reference:	ANSI C63.10-2013
Title:	American National Standard of Procedures for Compliance Testing of Unlicensed Wireless Devices
Reference:	KDB 414788 D01 Radiated Test Site v01r01
Title:	TEST SITES FOR RADIATED EMISSION MEASUREMENTS

2.4. Deviations from the Test Specification

For the measurements contained within this test report, there were no deviations from, additions to, or exclusions from the test specification identified above.

3. Equipment Under Test (EUT)

3.1. Identification of Equipment Under Test (EUT)

Brand Name:	maksense
Model Name or Number:	iLogger Case 4A
Serial Number:	2108840086
Hardware Version Number:	1.0.0
Firmware Version Number:	1.2.0
FCC ID:	2A350-ILOGGERCASE

3.2. Description of EUT

The equipment under test was a sample transport container with RFID 13.56MHz technology

3.3. Modifications Incorporated in the EUT

No modifications were applied to the EUT during testing.

3.4. Additional Information Related to Testing

Tested Technology:	RFID 13.56 MHz	
Category of Equipment:	Transceiver	
Channel Spacing:	Single channel device	
Transmit Frequency Range:	13.56 MHz	
Power supply Requirement(s):	4.5V DC 3x Type C 1.5V DC Type: Non rechargeable Brand: Procell	
Tested Temperature Range:	Minimum	-20 °C
	Maximum	+50 °C

3.5. Support Equipment

The following support equipment was used to exercise the EUT during testing:

A. Support Equipment (In-house)

Item	Description	Brand Name	Model Name or Number	Serial Number
	-/-	-/-	-/-	-/-

B. Support Equipment (Manufacturer supplied)

Item	Description	Brand Name	Model Name or Number	Serial Number
1	Sample Rack with Passive RFID 13.56 MHz Tag	maksense	iRACK	N/A

4. Operation and Monitoring of the EUT during Testing

4.1. Operating Modes

The EUT was tested in the following operating mode(s):

- Continuous transmitting modulated carrier at maximum power in RFID-13.56 MHz test mode.

4.2. Configuration and Peripherals

The EUT was tested in the following configuration(s):

- The customer supplied a document containing the setup instructions which name is “Quick Guide EMCW – iLogger Case” was used.
- As per the applicant’s declaration the external carry bag (iLogger Case 4A External Bag) forms an integral part of the product.
- To comply with the applicable regulatory requirements, the EUT will be marketed to consumer /end user with external carry bag (iLogger Case 4A External Bag).
- Before starting final measurements “worst case verifications” with the EUT inside external carry bag and EUT without external carry bag were performed.
- The EUT without external carry bag found to be the worst case in terms of H-Field & radiated spurious emissions. Therefore, all tests were performed with the EUT without external carry bag, thus this report only includes relevant results.
- For further details refer applicant’s declaration &/ product user manual ‘iLogger Case 4A User’s Guide’ v6.0.2 (English) 01/2022 which contains following general notice.
‘The internal case must not be removed from inside the external bag. To do so, please first remove the batteries following the instructions set below for batteries replacement’.

EUT Power supply:

- The EUT can powered via 4.5V DC with 3 type C fully charged alkaline batteries.
- All tests were performed with EUT powered via fully charged alkaline batteries except voltage variations.
- Voltage variations tests done with a laboratory power supply with varying the input voltage.

Test Mode Activations:

- For RFID 13.56 MHz test mode, after power on EUT activates the RFID communication signal continuously.
- Following customer supplied pre-programmed EUTs were used:
 - ‘RF ACTIVE’ was used to simulate Operating Mode for transmitter test modes.

Radiated Measurements:

- Before starting final radiated spurious emission measurements “worst case verification” with the EUT in Standing-position & Laying-position was performed by Lab.
- The EUT in Standing-position was found to be the worst case therefore this report includes relevant results.
- Radiated measurements below 30 MHz were performed with the EUT positioned on the turn table and rotating 360 degrees while the loop antenna height was set to 80 cm.
- Radiated measurements above 30 MHz were performed with the EUT positioned on the turn table and rotating 360 degrees while the antenna height varies from 1 to 4 m over the measurement frequency range.
- R&S®EMC32 Measurement Software V10.60.10 was used for the radiated spurious emission measurements.

5. Measurements, Examinations and Derived Results

5.1. General Comments

Measurement uncertainties are evaluated in accordance with current best practice. Our reported expanded uncertainties are based on standard uncertainties, which are multiplied by an appropriate coverage factor to provide a statistical confidence level of approximately 95%. Please refer to Section 6 *Measurement Uncertainty* for details.

In accordance with DAkkS requirements all the measurement equipment is on a calibration schedule. All equipment was within the calibration period on the date of testing.

5.2. Test Results**5.2.1. Transmitter 20 dB Bandwidth****Test Summary:**

Test Engineer:	Sercan, Usta	Test Dates:	01 March 2022
Test Sample Serial Number:	2108840086		
Test Site Identification	SR 9		

FCC Reference:	Part 15.215(c)
Test Method Used:	ANSI C63.10 Section 6.9.2 deviations in accordance with FCC Inquiry

Environmental Conditions:

Temperature (°C):	24
Relative Humidity (%):	38

Settings of the Instrument:

RBW/VBW	500 Hz / 2 kHz
Span	5 kHz
Sweep time	Auto
Detector	MaxPeak

Notes:

- Following reasonable deviations to test method ANSI C63.10 Section 6.9.2 were made:
Larger value of RBW (>1% to 5% of the OBW) and VBW than those mentioned in ANSI C63.10 Section 6.9.2 as a result of FCC KDB and FCC inquiry respectively.
- The n dB down function of the spectrum analyzer was set to 20 dB.
- The emission shown on 20 dB Bandwidth plots show the EUT's RFID 13.56 MHz fundamental for the tested channel.

Transmitter 20 dB Bandwidth (continued)

Test Setup:

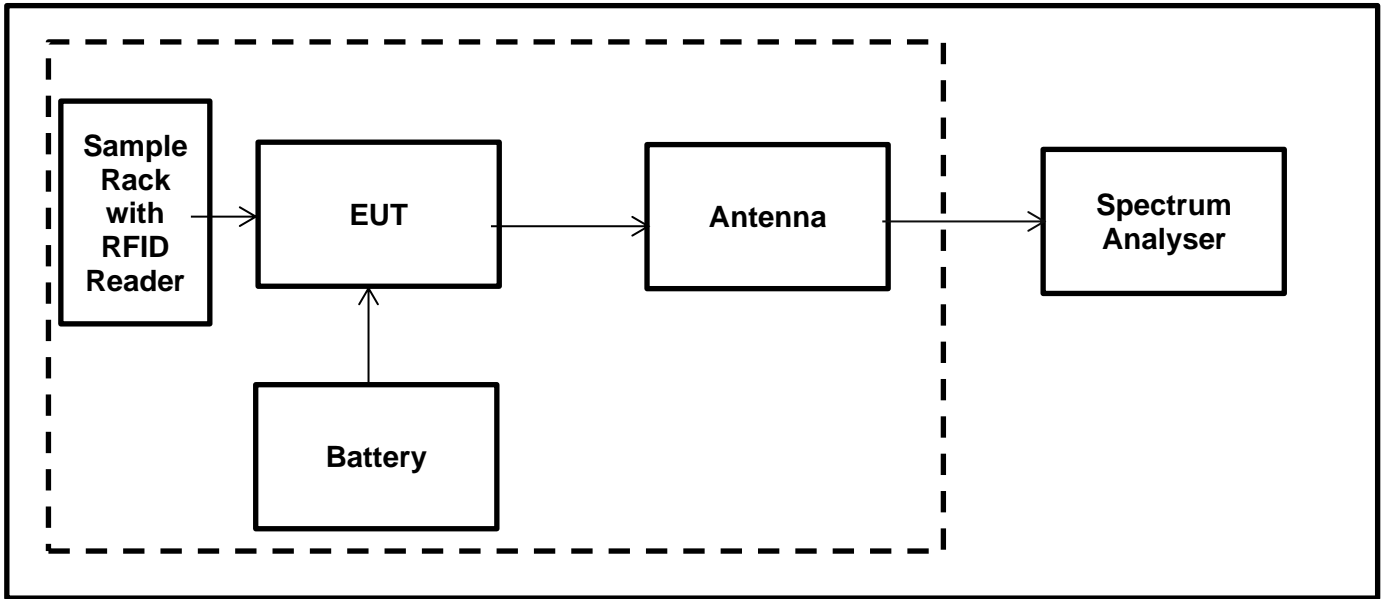

Transmitter 20 dB Bandwidth (continued)

Results: Fully Charged Batteries / RFID 13.56 MHz

RFID Channel	20 dB Bandwidth (kHz)
13.56 MHz	2.35

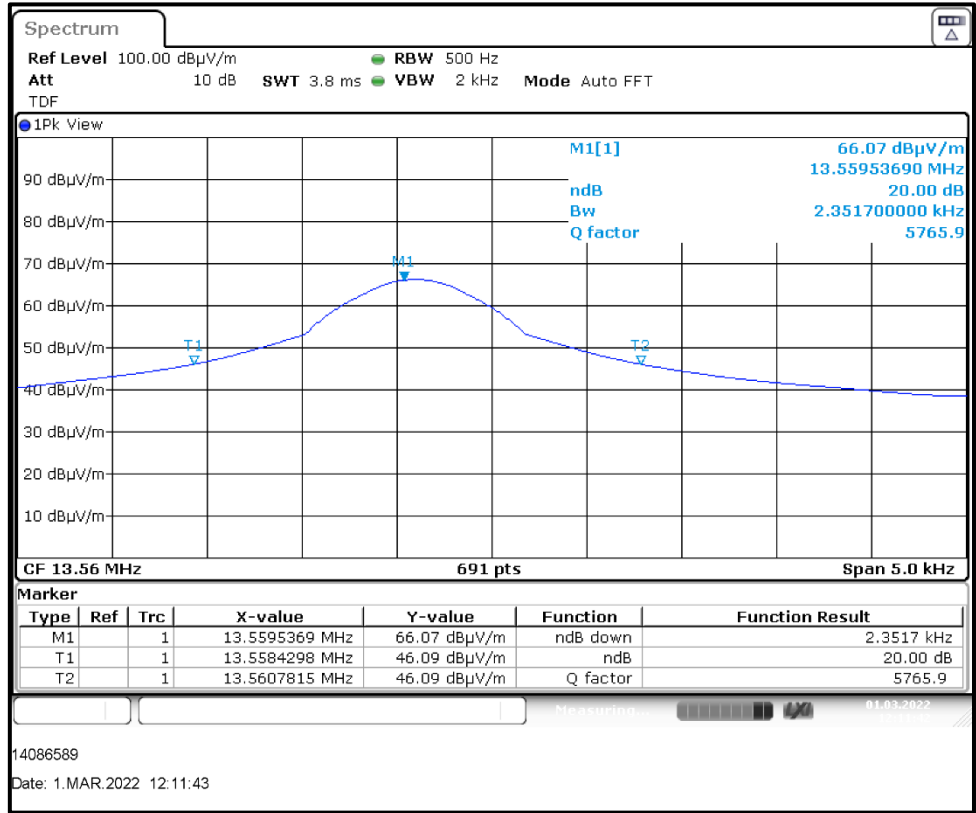

RFID 13.56 MHz

Result: Pass

5.2.2. Transmitter Fundamental Field Strength & Spectrum Mask**Test Summary:**

Test Engineer:	Sercan Usta	Test Date:	5 January 2022
Test Sample Serial Number:	2108840086		
Test Site Identification	SR 1/2		

FCC Reference:	Part 15.225(a)(b)(c)(d)
Test Method Used:	ANSI C63.10 Section 6.4

Environmental Conditions:

Temperature (°C):	22.2
Relative Humidity (%):	34.6

Note(s):

1. The limit is specified at a test distance of 30 metres. However, as specified by FCC Section 15.31 (f)(2), measurements may be performed at a closer distance and the measured level corrected to the specified measurement distance by using the square of an inverse linear distance extrapolation factor (40 dB/decade).
2. In accordance with FCC KDB 414788 D01 Radiated Test Site v01 an alternative Test Site was used. Instead of an OATS a Semi Anechoic Chamber was used where evidence was shown that the behaviour is the same. A maximum deviation of 1.38 dB for 13.56 MHz could be determined. This deviation is also taken into account to the result.
3. Therefore, applicable limits were extrapolated from 30 m to 3 m using a distance extrapolation factor of 40 dB/decade. The transducer factor on the measuring instrument was used to extrapolate the measured values from 30 m to 3 m using a distance extrapolation factor of 40 dB/decade.
4. Pre-scan measurements were performed using a spectrum analyser with a peak detector and measurement bandwidth of 10 kHz. The fundamental field strength was maximized by rotating the measurement antenna and EUT. The spectrum analyser was then switched to test receiver mode and the final measurement on the maximized level was performed.
5. Compliance with the spectrum mask is shown by final measurements performed in a semi-anechoic chamber. For the field strength measurements in a semi-anechoic chamber, a transducer factor on the measuring instrument was used to extrapolate the results at 3 m to a distance of 30 m. A distance extrapolation factor of 40 dB was used.
6. A transducer factor was used on the spectrum analyser during measurement. This factor includes correction between the fixed gain of the magnetic loop antenna and the calibration values. It also includes the value of the RF cable used to connect the antenna to the spectrum analyser which was incorporated into the annual calibration of the magnetic loop antenna.
7. For the emissions appearing within the 13.110-14.010 MHz band, compliance with the spectrum mask is shown in accordance with FCC Part 15.225(a)(b)(c)(d) limits.
8. The emissions shown at frequencies approximately at 13.56 MHz on the plot represent EUT's fundamental field strength for RFID 13.56 MHz.
9. For the emissions appearing outside of the 13.110-14.010 MHz band, compliance with the spectrum mask is shown in accordance with FCC Part 15.225(d) referencing FCC Part 15.209 general radiated emission limits.

Transmitter Fundamental Field Strength & Spectrum Mask (continued)
Open Area Test Site

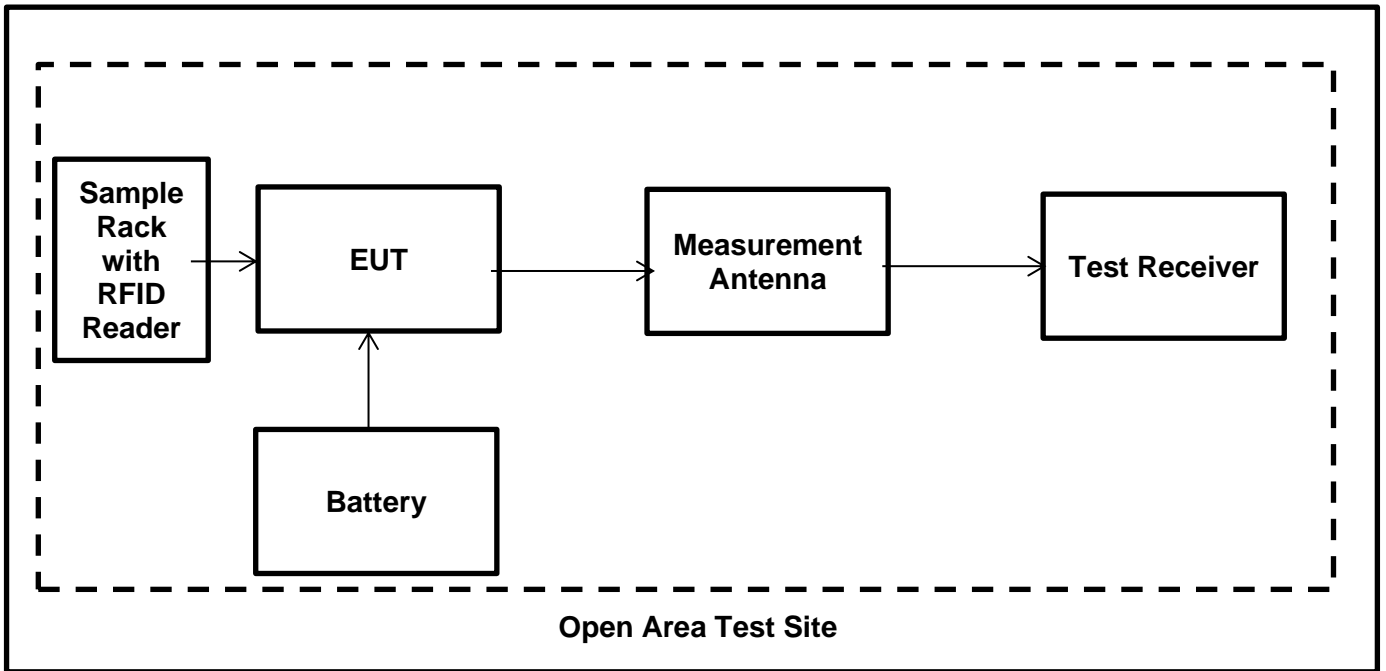

Semi Anechoic Chamber

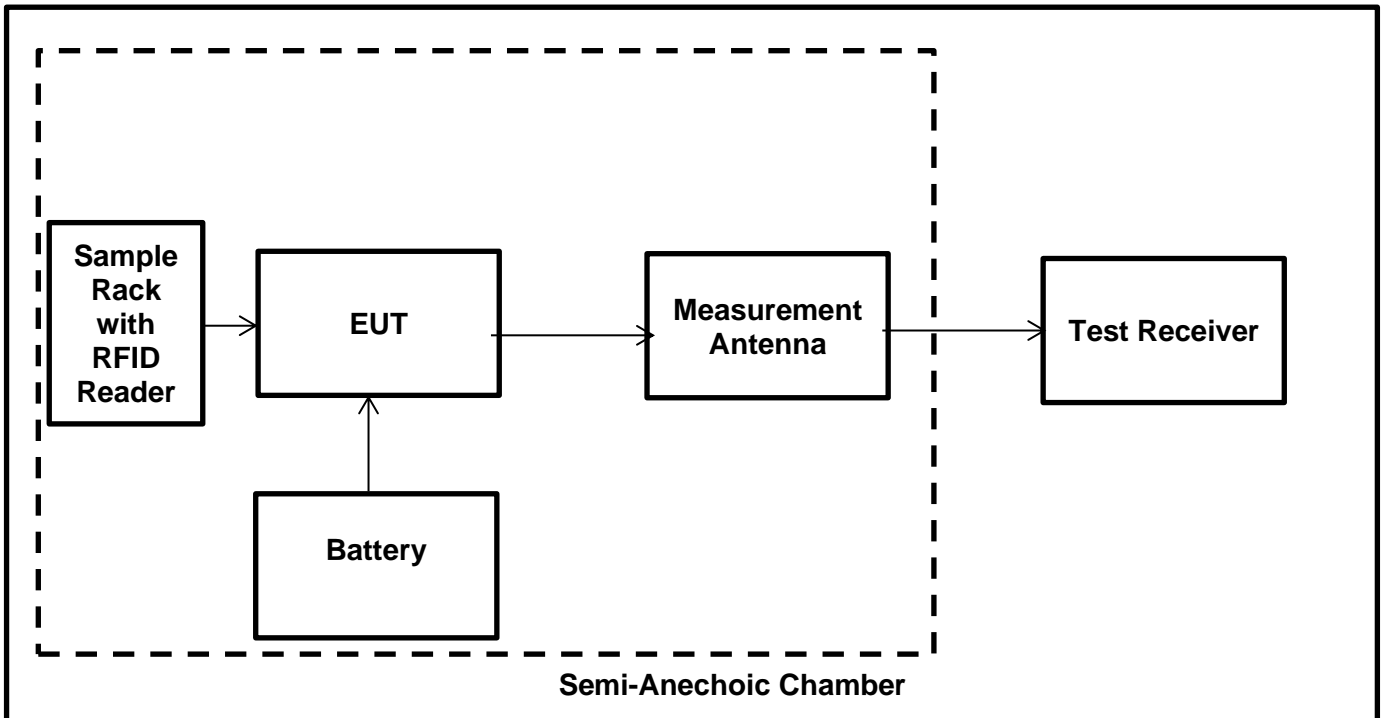

Transmitter Fundamental Field Strength & Spectrum Mask (continued)
Results: Fully Charged Batteries / RFID 13.56 MHz

Frequency Band (MHz)	Emission Frequency (MHz)	Loop Antenna Orientation	MaxPeak Emission Level at 3 m (dBµV/m) <small>Note 3</small>	Deviation from OATS to SAC (dB)	Deviation Corrected Level at 3 m (dBµV/m)	Limit at 3 m (dBµV/m) <small>Note 3</small>	Margin (dB)	Result
12.000 to 13.110	All emissions were found to be below system noise floor							Complied
13.110 to 13.410	All emissions were found to be below system noise floor							Complied
13.410 to 13.553	13.447	90° to EUT	47.05	1.38	48.43	90.50	42.07	Complied
13.553 to 13.567	13.560	90° to EUT	65.27	1.38	66.65	124.00	67.35	Complied
13.567 to 13.710	All emissions were found to be below system noise floor							Complied
13.710 to 14.010	All emissions were found to be below system noise floor							Complied
14.010 to 15.000	All emissions were found to be below system noise floor							Complied

Transmitter Fundamental Field Strength & Spectrum Mask (continued)
Results: Fully Charged Batteries / RFID 13.56 MHz

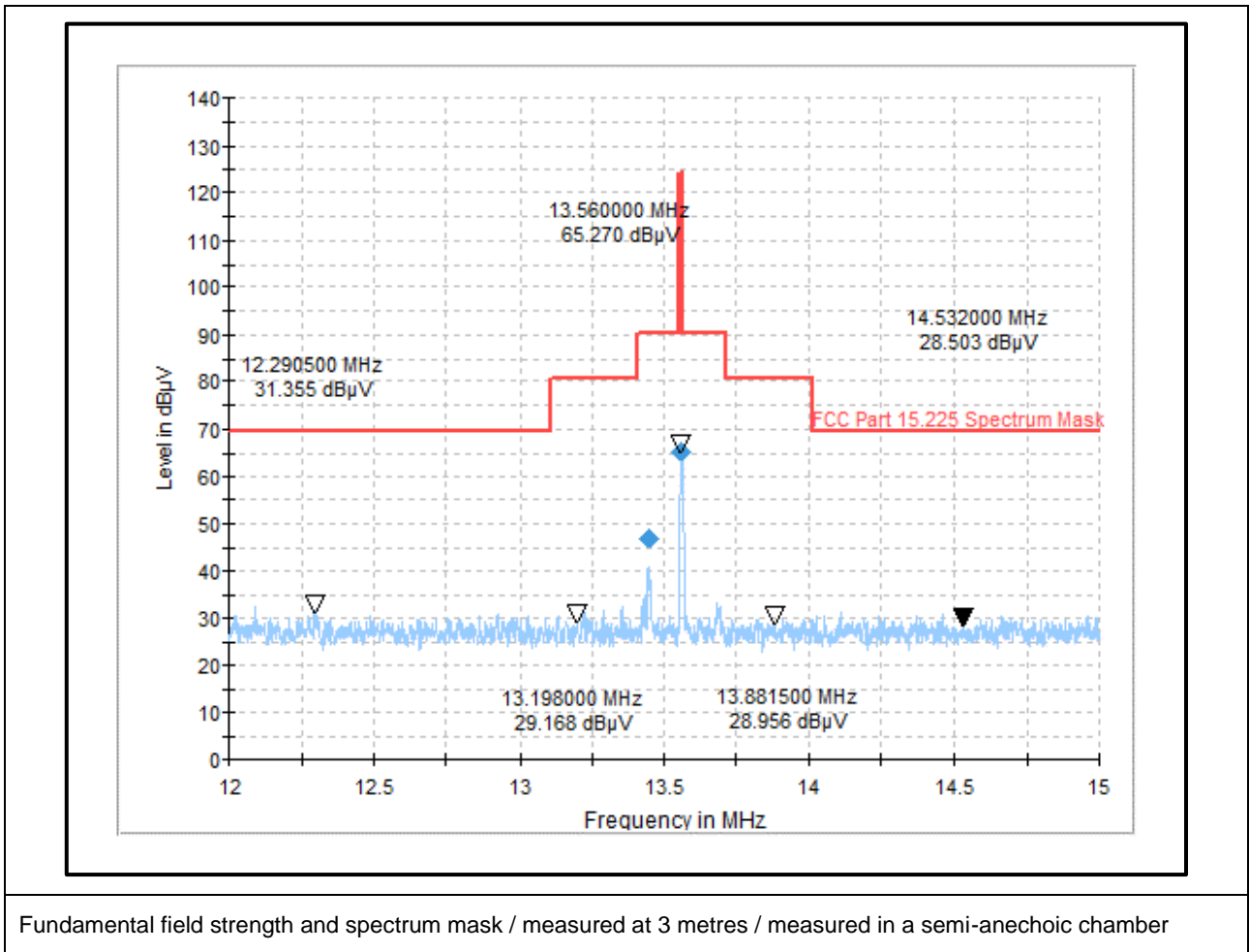

Fundamental field strength and spectrum mask / measured at 3 metres / measured in a semi-anechoic chamber

5.2.3. Transmitter Radiated Spurious Emissions**Test Summary:**

Test Engineer:	Sercan Usta	Test Date:	5 January 2022
Test Sample Serial Number:	2108840086		
Test Site Identification	SR 1/2		

FCC Reference:	Parts 15.225(d) & 15.209(a)
Test Method Used:	ANSI C63.10:2013 Sections 6.3 and 6.4
Frequency Range:	9 kHz to 30 MHz

Environmental Conditions:

Temperature (°C):	22.2
Relative Humidity (%):	34.6

Note(s):

- In accordance with FCC KDB 414788, an alternative test site may be used for the measurement below 30 MHz (The OATS / SAC comparison data is available upon request). Therefore the result from the semi-anechoic chamber tests is shown in this section of the test report.
- The limits are specified at a test distance of 30 m & 300 m. However, as specified by FCC Section 15.31 (f)(2), measurements may be performed at a closer distance and the measured level corrected to the specified measurement distance by using the square of an inverse linear distance extrapolation factor.
- Therefore the limit values are extrapolated to a measurement distance of 3 m.
 - 9 kHz- 490 kHz: limits extrapolated from 300 m to 3 m adding 80 dB at 40 dB /decade.
 - 490 kHz-1705 kHz: limits extrapolated from 30 m to 3 m by adding 40 dB at 40 dB /decade.
- All emissions shown on the pre-scan plots were investigated and found to be ambient or > 20 dB below the appropriate limit.
- Measurements below 30 MHz were performed in a semi-anechoic chamber SR1/ 2 (Asset Number 1603665) at a distance of 3 m. The EUT was placed at a height of 80 cm above the reference ground plane in the centre of the chamber turntable. The measurement loop antenna height was 1 m.
- Pre-scans were performed and markers placed on the highest measured levels. The test receiver was set to:
 - Frequency range: 9 kHz-150 kHz : RBW: 300 Hz /VBW: 1 kHz
 - Frequency range: 150 kHz – 30 MHz: RBW: 10 kHz /VBW: 30 kHz
 - Detector: Max-Peak detector
 - Trace Mode: Max Hold
- The emissions shown at frequencies approximately 13.56 MHz on the 9 kHz to 30 MHz plots are the EUT RFID 13.56 MHz fundamental for the tested channel.

Transmitter Radiated Spurious Emission test setup

Test Setup:

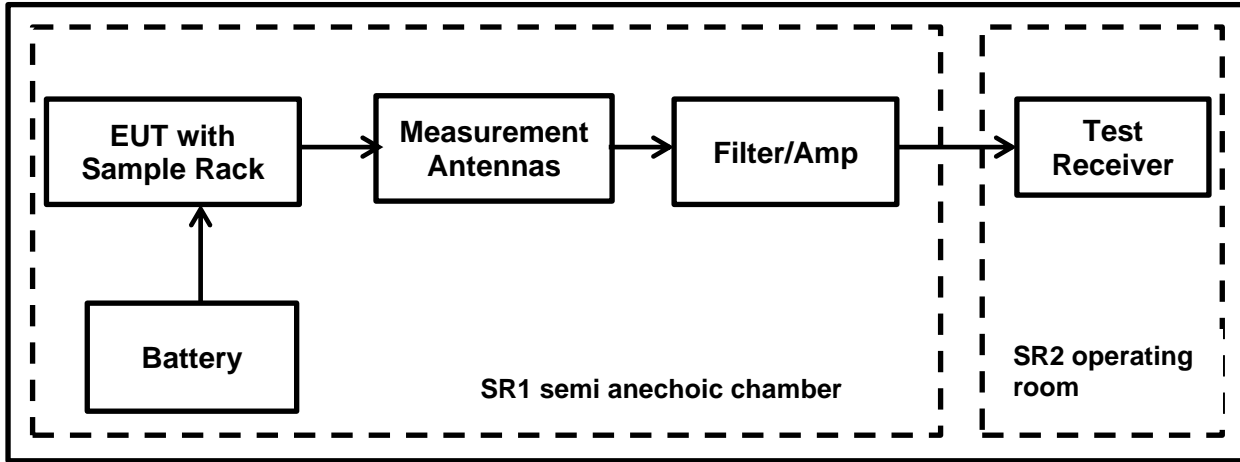

Transmitter Radiated Emissions (continued)

Results: Fully Charged Batteries / RFID 13.56 MHz

Frequency (MHz)	Antenna Polarization	Level (dB μ V/m)	Limit (dB μ V/m)	Margin (dB)	Result
No critical spurious emissions were found					

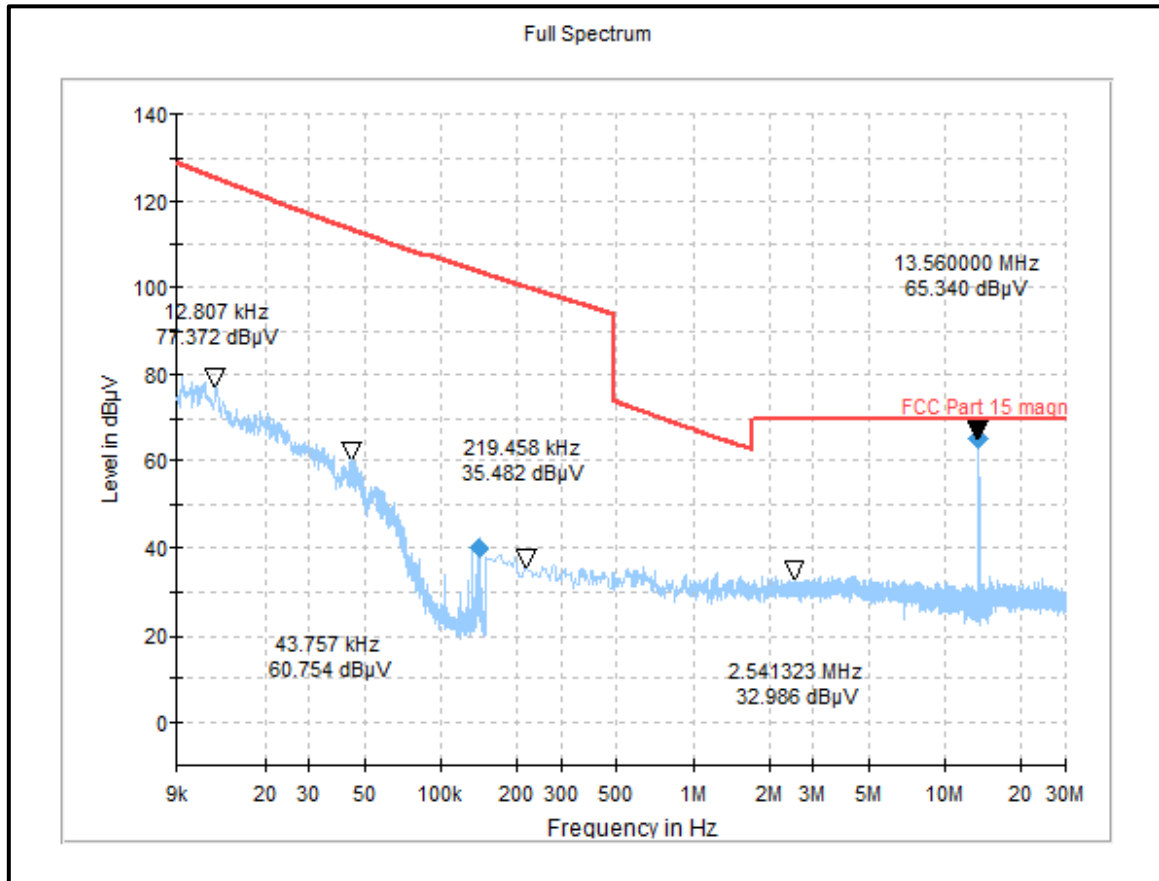

Result: Pass

Transmitter Radiated Emissions (continued)

Test Summary:

Test Engineer:	Sercan Usta	Test Date:	5 January 2022
Test Sample Serial Number:	2108840086		
Test Site Identification	SR 1/2		

FCC Reference:	Parts 15.225(d) & 15.209(a)
Test Method Used:	ANSI C63.10:2013 Sections 6.3 and 6.5
Frequency Range:	30 MHz to 1000 MHz

Environmental Conditions:

Temperature (°C):	22.2
Relative Humidity (%):	34.6

Note(s):

1. All emissions shown on the pre-scan plots were investigated and found to be ambient or > 20 dB below the appropriate limit.
2. Measurements below 1 GHz were performed in a semi-anechoic chamber SR1/ 2 (Asset Number 1603665) at a distance of 3 m. The EUT was placed at a height of 80 cm above the reference ground plane in the centre of the chamber turntable. Maximum emission levels were determined by height searching the measurement antenna over the range 1 m to 4 m.
3. Pre-scans were performed and markers placed on the highest measured levels. The test receiver resolution bandwidth was set to 100 kHz and video bandwidth 300 kHz. A peak detector was used, sweep time was set to auto and trace mode was Max Hold.

Test Setup:

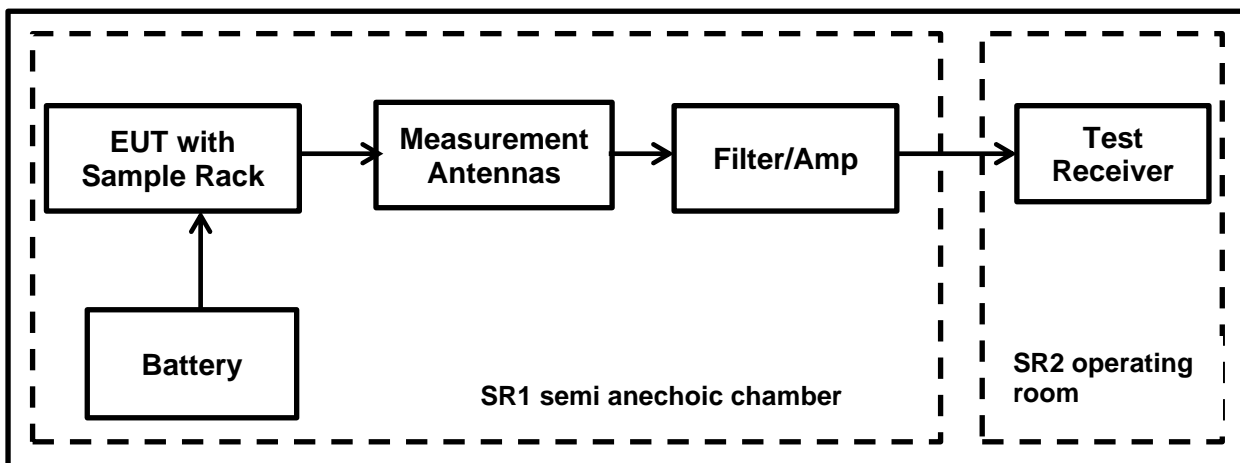

Transmitter Radiated Emissions (continued)

Results: Fully Charged Batteries / RFID 13.56 MHz

Frequency (MHz)	Antenna Polarization	MaxPeak Level (dB μ V/m)	Limit (dB μ V/m)	Margin (dB)	Result
No critical spurious emissions were found					

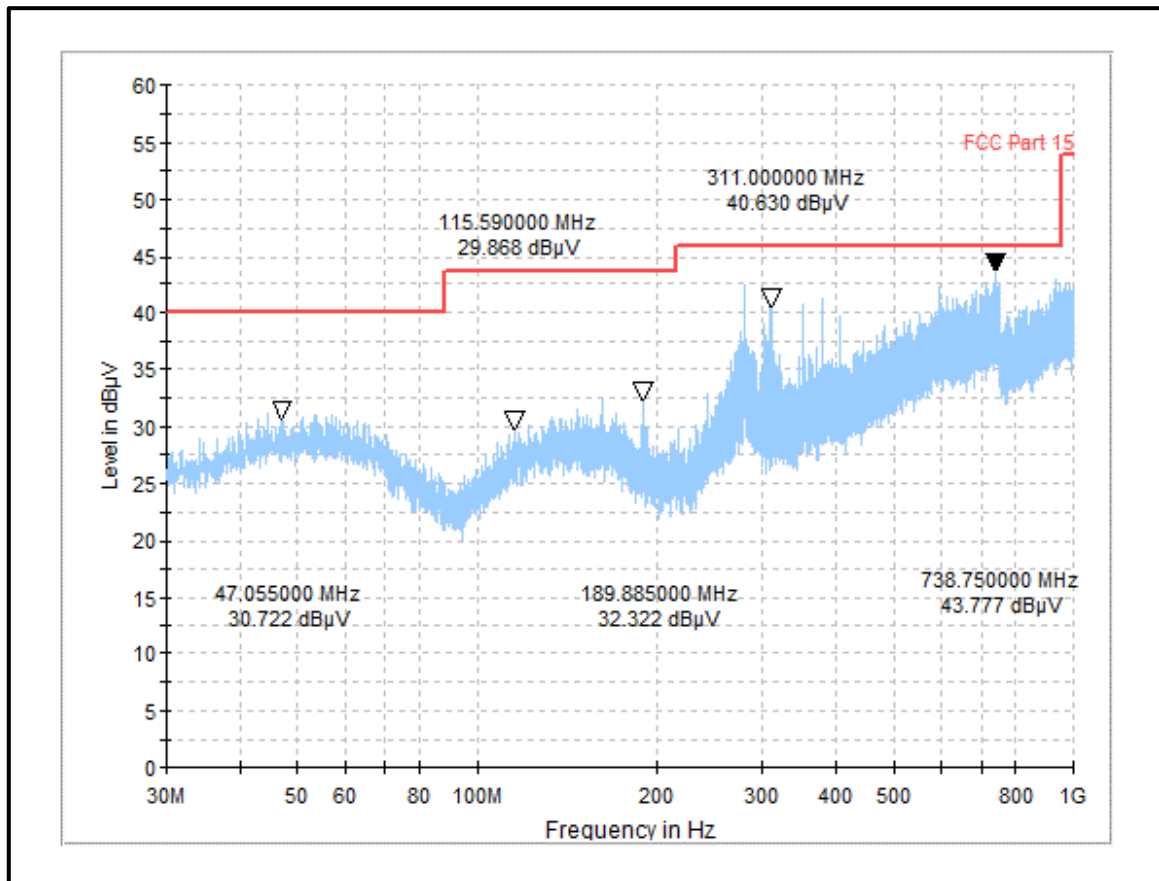

Result: Pass

5.2.4. Transmitter Frequency Stability (Temperature & Voltage Variation)**Test Summary:**

Test Engineer:	Sercan Usta	Test Dates:	08 & 09 February 2022
Test Sample Serial Number:	2108840086		
Test Site Identification	SR 9		

FCC Reference:	Part 15.225(e)
Test Method Used:	ANSI C63.10 Sections 6.8.1 and 6.8.2

Environmental Conditions:

Ambient Temperature (°C):	26
Ambient Relative Humidity (%):	30

Settings of the Instrument

RBW/VBW	30 Hz/30 kHz
Span	4 kHz
Sweep Time	Auto
Sweep Mode	Single Sweep
Detector	Peak
Marker Function	Signal Count

Note(s):

1. The EUT was kept inside the environmental/climatic test chamber. The tests were performed with extreme temperature & extreme voltage variations.
2. The temperature variations were monitored throughout the tests using a calibrated digital thermometer. The voltage variations were monitored throughout the tests using a calibrated digital multimeter.
3. For accurate measurement of frequency deviations, Signal Count / frequency counter function was activated on the spectrum analyser.
4. The applicant's declared operating frequency 13.560 MHz was used as reference frequency.
5. The difference between operating /reference frequency & measured frequency was reported as a frequency error.
6. The frequency tolerance of the carrier signal shall be maintained within $\pm 0.01\%$ or 100 ppm of the operating frequency

Transmitter Frequency Stability (Temperature & Voltage Variation) (continued)

Test Setup :

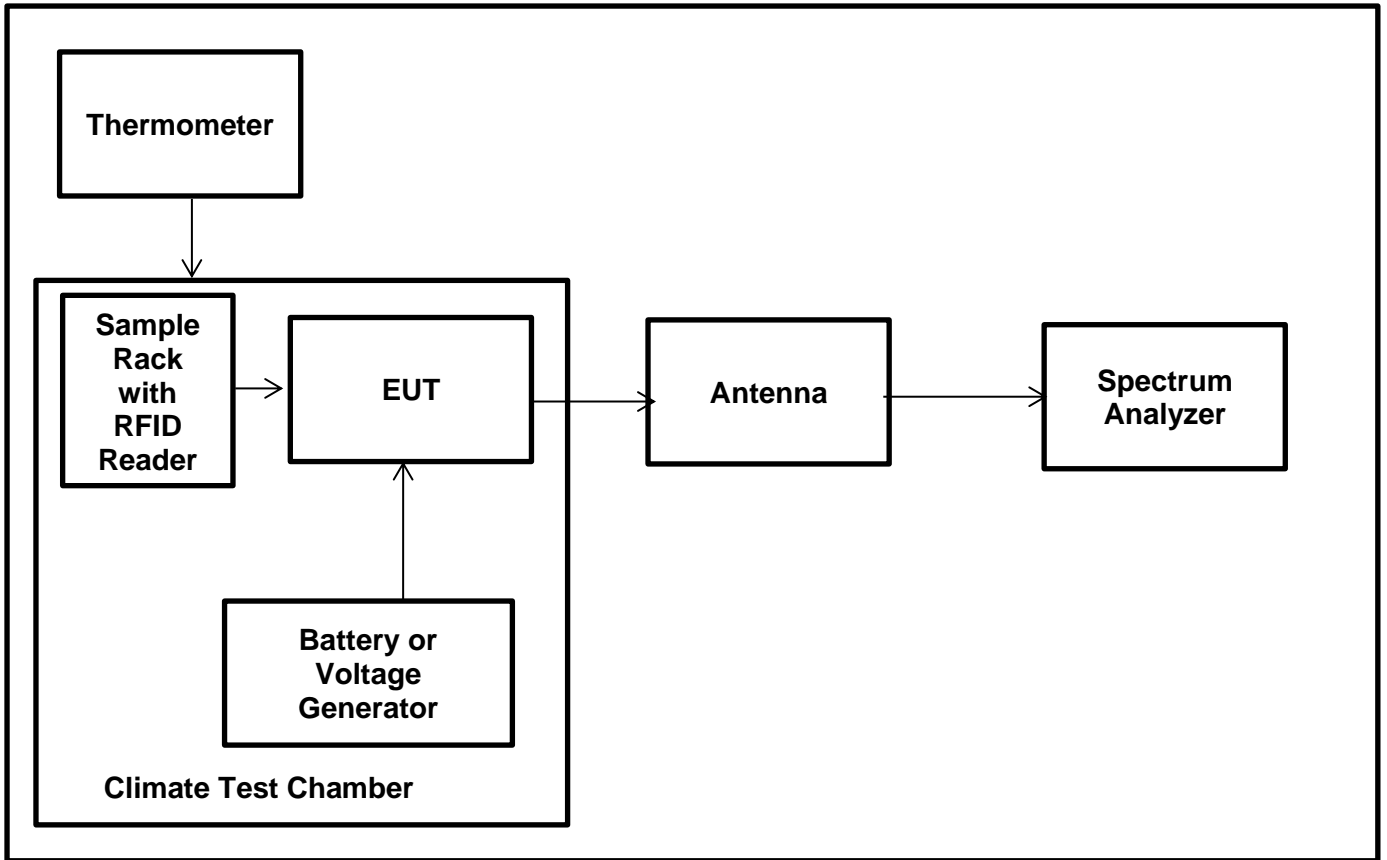

Transmitter Frequency Stability (Temperature Variation) (continued)**Results: Fully Charged Batteries / RFID 13.56 MHz / Temperature Variations**

Extreme Temperature (°C)	Time after EUT Power-up	Measured Frequency (MHz)	Frequency Error		Frequency Error Limits		Result
			%	ppm	%	ppm	
-20	at 0 minutes	13.559605578	-0.002908717	-29.09	± 0.01	± 100	Complied
	at 2 minutes	13.559605542	-0.002908982	-29.09	± 0.01	± 100	Complied
	at 5 minutes	13.559607283	-0.002896143	-28.96	± 0.01	± 100	Complied
	at 10 minutes	13.559611689	-0.002863650	-28.64	± 0.01	± 100	Complied
-10	at 0 minutes	13.559600871	-0.002943429	-29.43	± 0.01	± 100	Complied
	at 2 minutes	13.559599653	-0.002952412	-29.52	± 0.01	± 100	Complied
	at 5 minutes	13.559601815	-0.002936468	-29.36	± 0.01	± 100	Complied
	at 10 minutes	13.559601297	-0.002940288	-29.40	± 0.01	± 100	Complied
0	at 0 minutes	13.559600723	-0.002944521	-29.45	± 0.01	± 100	Complied
	at 2 minutes	13.559600723	-0.002944521	-29.45	± 0.01	± 100	Complied
	at 5 minutes	13.559598860	-0.002958260	-29.58	± 0.01	± 100	Complied
	at 10 minutes	13.559600881	-0.002943355	-29.43	± 0.01	± 100	Complied
+10	at 0 minutes	13.559605060	-0.002912537	-29.13	± 0.01	± 100	Complied
	at 2 minutes	13.559603801	-0.002921822	-29.22	± 0.01	± 100	Complied
	at 5 minutes	13.559605745	-0.002907485	-29.07	± 0.01	± 100	Complied
	at 10 minutes	13.559601135	-0.002941482	-29.41	± 0.01	± 100	Complied
+20	at 0 minutes	13.559610290	-0.002873968	-28.74	± 0.01	± 100	Complied
	at 2 minutes	13.559611436	-0.002865516	-28.66	± 0.01	± 100	Complied
	at 5 minutes	13.559606705	-0.002900406	-29.00	± 0.01	± 100	Complied
	at 10 minutes	13.559611637	-0.002864034	-28.64	± 0.01	± 100	Complied
+30	at 0 minutes	13.559612164	-0.002860147	-28.60	± 0.01	± 100	Complied
	at 2 minutes	13.559610675	-0.002871128	-28.71	± 0.01	± 100	Complied
	at 5 minutes	13.559609835	-0.002877323	-28.77	± 0.01	± 100	Complied
	at 10 minutes	13.559610608	-0.002871622	-28.72	± 0.01	± 100	Complied
+40	at 0 minutes	13.559612412	-0.002858319	-28.58	± 0.01	± 100	Complied
	at 2 minutes	13.559606037	-0.002905332	-29.05	± 0.01	± 100	Complied
	at 5 minutes	13.559605833	-0.002906836	-29.07	± 0.01	± 100	Complied
	at 10 minutes	13.559606181	-0.002904270	-29.04	± 0.01	± 100	Complied
+50	at 0 minutes	13.559605536	-0.002909027	-29.09	± 0.01	± 100	Complied
	at 2 minutes	13.559607001	-0.002898223	-28.98	± 0.01	± 100	Complied
	at 5 minutes	13.559607425	-0.002895096	-28.95	± 0.01	± 100	Complied
	at 10 minutes	13.559605345	-0.002910435	-29.10	± 0.01	± 100	Complied

Result: Pass

Transmitter Frequency Stability (Temperature & Voltage Variation) (continued)

Results: Fully Charged Battery / RFID 13.56 MHz / Voltage Variations

Extreme Voltage Conditions	Extreme DC Voltage (V)	Measured Frequency (MHz)	Frequency Error		Frequency Error Limits		Result
			%	ppm	%	ppm	
85% of Rated Voltage	3.8	13.559606849	-0.0028993	-28.99	± 0.01	± 100	Complied
Rated Voltage	4.5	13.559605036	-0.0029127	-29.13	± 0.01	± 100	Complied
115% of Rated Voltage	5.2	13.559606892	-0.0028990	-28.99	± 0.01	± 100	Complied

Result: Pass

6. Measurement Uncertainty

The expression of uncertainty of a measurement result allows realistic comparison of results with reference values and limits given in specifications and standards.

The uncertainty of the result may need to be taken into account when interpreting the measurement results.

The reported expanded uncertainties below are based on a standard uncertainty multiplied by an appropriate coverage factor such that a confidence level of approximately 95% is maintained. For the purposes of this document “approximately” is interpreted as meaning “effectively” or “for most practical purposes”.

Measurement Type	Confidence Level (%)	Calculated Uncertainty
AC Conducted Spurious Emissions	95%	±2.49 dB
20 dB Bandwidth	95%	±0.87 %
Fundamental Field Strength	95%	±3.10 dB
Radiated Spurious Emissions	95%	±3.10 dB
Frequency Stability	95%	±92 Hz

The methods used to calculate the above uncertainties are in line with those recommended within the various measurement specifications. Where measurement specifications do not include guidelines for the evaluation of measurement uncertainty the published guidance of the appropriate accreditation body is followed.

7. Used equipment

Test site: SR 1/2

ID	Manufacturer	Type	Model	Serial	Calibration Date	Cal. Cycle (months)
1	Rohde & Schwarz	Antenna, Loop	HFH2-Z2	831247/012	10/07/2020	36
460	Deisl	Turntable	DT 4250 S	n/a	n/a	n/a
465	Schwarzbeck	Antenna, Trilog Broadband	VULB 9168	9168-240	02/09/2020	24
587	Maturo	antenna mast, tilting	TAM 4.0-E	011/7180311	n/a	n/a
588	Maturo	Controller	NCD	029/7180311	n/a	n/a
591	Rohde & Schwarz	Receiver	ESU 40	100244/040	28/06/2021	12
608	Rohde & Schwarz	Switch Matrix	OSP 120	101227	lab verification	n/a
628	Maturo	Antenna mast	CAM 4.0-P	224/19590716	n/a	n/a
629	Maturo	Kippeinrichtung	KE 2.5-R-M	MAT002	n/a	n/a
-/-	Testo	Thermo-Hygrometer	608-H1	01	lab verification	n/a
328	SPS	AC/DC power distribution system	PAS 5000	A2464 00/2 0200	lab verification	n/a
1603665	Siemens Matsushita Components	semi-anechoic chamber SR1/2	-/-	B83117-A1421-T161	n/a	n/a

Test site: SR 7/8

ID	Manufacturer	Type	Model	Serial	Calibration Date	Cal. Cycle (months)
23	Rohde & Schwarz	Artificial Mains	ESH3-Z5	831767/013	14/07/2021	12
28	Rohde & Schwarz	Passive Probe	ESH2-Z3	none	11/07/2021	36
349	Rohde & Schwarz	Receiver, EMI Test	ESIB7	836697/009	13/07/2021	12
351	Rohde & Schwarz	network, Artificial Mains	ESH3-Z5	862770/018	14/07/2021	12
564	Teseq	Impedance stabilisation network (ISN)	ISN T800	26076	14/07/2021	24
616	Rohde & Schwarz	ISN	ENY81-CA6	101656	07/07/2021	36
-/-	Testo	Thermo-Hygrometer	608-H1	08	lab verification	n/a
327	SPS	AC/DC power distribution system	PAS 5000	A2464 00/1 0200	lab verification	n/a

Test site: SR 9

ID	Manufacturer	Type	Model	Serial	Calibration Date	Cal. Cycle (months)
625	Schwarzbeck	Antenna, H-field	HFSL 7101	109	lab verification only relative measurements	n/a
637	Rohde & Schwarz	Spectrum Analyser	FSV40	101587	13/07/2021	12
-/-	Testo	Thermo-Hygrometer	608-H1	07	lab verification	n/a
645	Weiss Umwelttechnik	Climatic Chamber	LabEvent T/110/70/3	5822619794 0010	lab verification	n/a
327	SPS	AC/DC power distribution system	PAS 5000	A2464 00/1 0200	lab verification	n/a

8. Open-Area-Test Site comparison

GPS coordinates

Latitude: 48.765746, Longitude: 9.250684



Open-Area-Test Site comparison (continued)

The following listed equipment was used for the measurement:

Manufacturer	Type	Model	Frequency Range
Rohde & Schwarz	Signal generator	SML03	9 kHz – 30 MHz
Rohde & Schwarz	Receiver, EMI Test	ESIB7	20 Hz – 7 GHz
Rohde & Schwarz	Antenna, Loop	HFH2-Z2	1 kHz – 30 MHz
ETS LINDGREN	Antenna, Loop	6512	1 kHz – 30 MHz
HUBER+SUHNER	RF Cable	-/-	-/-
Elspec	BNC Cable	-/-	-/-

The transmit signal to the ETS Lindgren loop antenna is supplied by the SML signal generator.

The distance of the transmit and receive antenna was 3 m. No other distances can be achieved in SR1 so 10 m and 30 m distances are not possible. Due to this no comparison is possible.

The Results are valid for equipment which is not larger as the loop antenna which represents in the comparison the EUT.

If an EUT is bigger measurements on an OATS are needed.

The measurement was performed on the lowest frequency 9 kHz and was increased by 10 kHz Steps up to 100 kHz. Then the step size was 100 kHz up to 1000 kHz. From 1 MHz up to the last frequency of 30 MHz the step size was 1 MHz. The HFH2-Z2 loop antenna placed at 80 cm height was used as the receive antenna. The intercepted RF signal from this antenna was measured with the ESIB7 Test Receiver and the values were recorded accordingly.

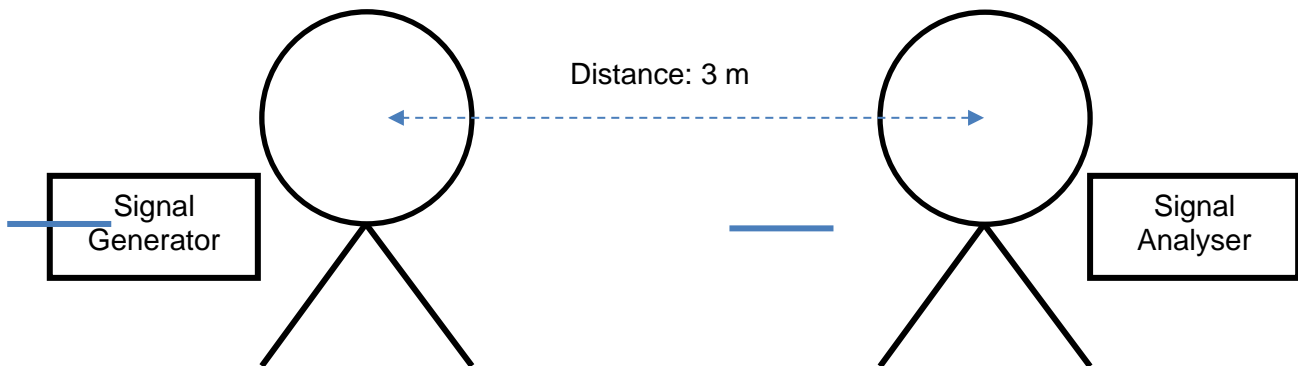

Open-Area-Test Site comparison (continued)

Numeric values:

Frequency (MHz)	0.01	0.02	0.03	0.04	0.05	0.06	0.07	0.08	0.09	0.10	0.125	0.20
SR1 Measured power (dB μ V)	87.91	87.22	87.01	86.98	86.40	86.32	85.98	85.20	84.30	83.80	82.96	82.55
OATS Measured power (dB μ V)	86.22	87.42	87.50	86.49	86.01	85.39	84.32	84.29	84.20	83.10	83.60	82.32
Delta (dB)	-1.69	0.20	0.49	-0.49	-0.39	-0.93	-1.66	-0.91	-0.10	-0.70	0.64	-0.23

Frequency (MHz)	0.30	0.40	0.50	0.60	0.70	0.80	0.90	1.00	2.00	3.00	4.00	5.00
SR1 Measured power (dB μ V)	81.98	81.23	80.39	80.00	79.53	79.10	78.87	78.20	77.60	77.01	76.32	76.04
OATS Measured power (dB μ V)	80.84	80.49	79.58	79.58	78.85	78.59	77.69	77.50	77.91	76.90	75.45	74.90
Delta (dB)	-1.14	-0.74	-0.81	-0.42	-0.68	-0.51	-1.18	-0.70	0.31	-0.11	-0.87	-1.14

Frequency (MHz)	6.00	7.00	8.00	9.00	10.00	11.00	12.00	13.00	13.56	14.00	15.00	16.00
SR1 Measured power (dB μ V)	75.98	75.43	75.20	74.97	74.59	74.32	74.05	73.83	73.50	73.22	73.20	73.05
OATS Measured power (dB μ V)	74.94	74.09	74.11	73.58	73.87	74.38	74.84	74.31	74.88	74.29	73.90	73.93
Delta (dB)	-1.04	-1.34	-1.09	-1.39	-0.72	0.06	0.79	0.48	1.38	1.07	0.70	0.88

Frequency (MHz)	17.00	18.00	19.00	20.00	21.00	22.00	23.00	24.00	25.00	26.00	27.00	28.00	29.00	30.00
SR1 Measured power (dB μ V)	73.00	72.86	72.74	72.64	72.50	72.52	72.39	72.20	72.04	71.97	71.86	71.64	71.41	71.27
OATS Measured power (dB μ V)	73.70	73.98	72.90	72.60	72.45	72.34	72.59	72.59	71.97	71.59	71.58	71.88	71.98	72.49
Delta (dB)	0.70	1.12	0.16	-0.04	-0.05	-0.18	0.20	0.39	-0.07	-0.38	-0.28	0.24	0.57	1.22

Open-Area-Test Site comparison (continued)

Graph

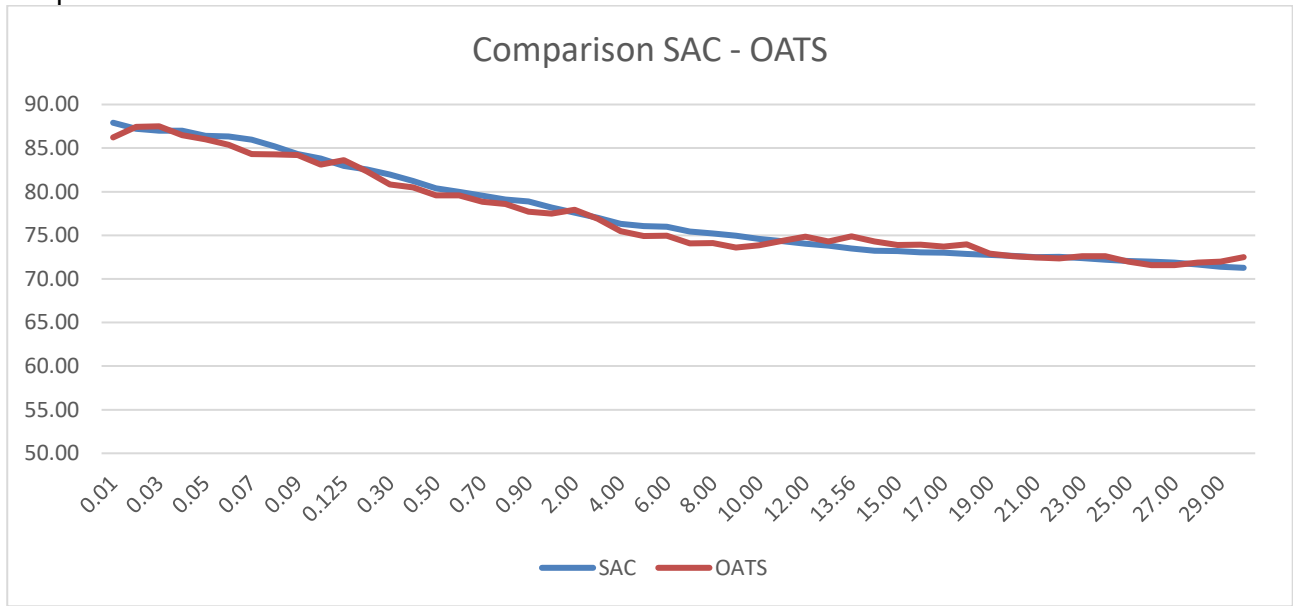

Conclusion: Maximum difference is 1.69 dB @ 9 kHz

9. Report Revision History

Version Number	Revision Details		
	Page No(s)	Clause	Details
1.0	32	-	Initial Version
<p>Test Report Version 1.1 supersede Version 1.0 with immediate effect Test Report No. UL-RPT-RP-14086589-1316-FCC Version 1.1, Issue Date 14 MARCH 2022 replaces Test Report No. UL-RPT-RP-14086589-1316-FCC Version 1.0, Issue Date 02 MARCH 2022, which is no longer valid.</p>			
1.1	as below	as below	Current Version
	6	2.3	KDB 174176 reference removed
	9	4.2	"All tests were performed with EUT powered via fully charged alkaline batteries." Removed.
	9	4.2	"All tests were performed with EUT powered via fully charged alkaline batteries except voltage variations. Voltage variations tests done with a laboratory power supply with varying the input voltage." Added.
	23	5.2.4	09 February Date Added
	26	5.2.4	Voltage extreme results added
	21	5.2.3	6 dB replaced with 20 dB

--END of Test Report--