

FCC Warning Statement

Changes or modifications not expressly approved by the party responsible for compliance could void the user's authority to operate the equipment.

NOTE: This equipment has been tested and found to comply with the limits for a Class B digital device, pursuant to Part 15 of the FCC Rules. These limits are designed to provide reasonable protection against harmful interference in a residential installation. This equipment generates uses and can radiate radio frequency energy and, if not installed and used in accordance with the instructions, may cause harmful interference to radio communications. However, there is no guarantee that interference will not occur in a particular installation. If this equipment does cause harmful interference to radio or television reception, which can be determined by turning the equipment off and on, the user is encouraged to try to correct the interference by one or more of the following measures:

- Reorient or relocate the receiving antenna.
- Increase the separation between the equipment and receiver.
- Connect the equipment into an outlet on a circuit different from that to which the receiver is connected.
- Consult the dealer or an experienced radio/TV technician for help.

NOTE: This device and its antenna(s) must not be co-located or operation in conjunction with any other antenna or transmitter.

RF Exposure Statement

- To maintain compliance with FCC's RF Exposure guidelines, this equipment should be installed and operated with minimum distance of 20cm from the radiator to your body.
- This device and its antenna(s) must not be co-located or operation in conjunction with any other antenna or transmitter.



UNPACKING CHECKLIST



printer

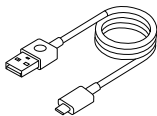

Data cable



Installation guide



APPEARANCE COMPONENT

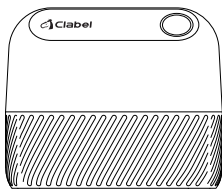

Front view

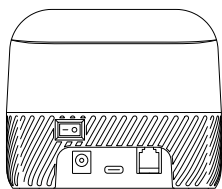

Rear view

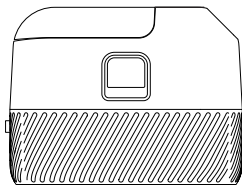

Left side view

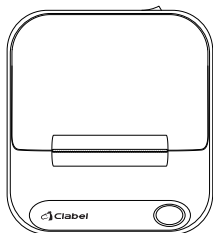

Top view

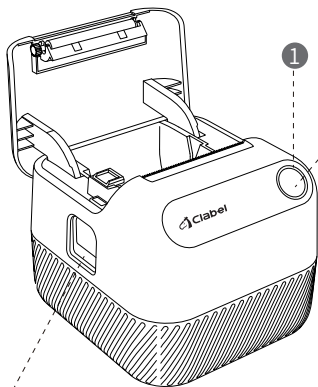

1 Indicator light (red and blue)

2 Key

3 Uncovering key (press the uncovering key down with your thumb, to open the case cover)

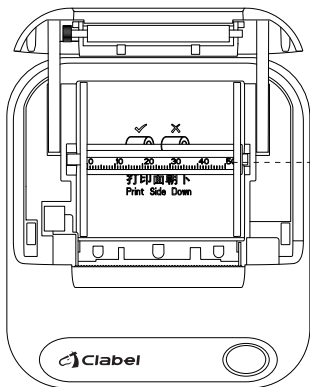

4 Label shaft + baffle,
to secure the consumables.

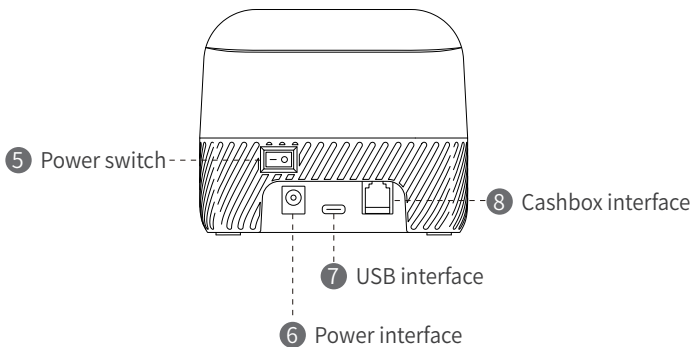

⑤ · “1” means that the printer is started;
“0” means that the printer is closed.

⑥ · Connect round-hole power cord.

⑦ · Connect to computer for printing.

⑧ · Connect to cashbox.

3

INSTALLATION OF CONSUMABLES

1. Make sure that the printer is powered on and started up.

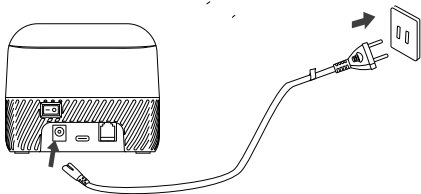

2. Press the uncovering button down with your thumb, to open the paper case cover.

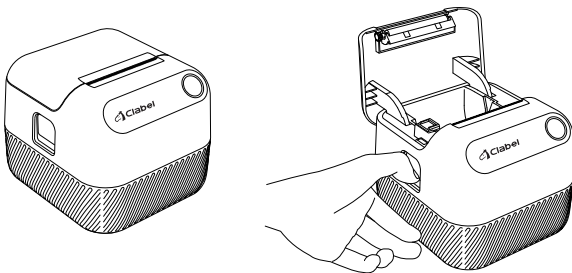

3. Take the label shaft and baffle out, and slip the roll over label shaft.

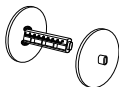

①

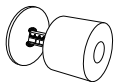

②

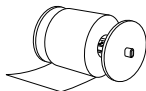

③

Install roll set into the printer from top to bottom

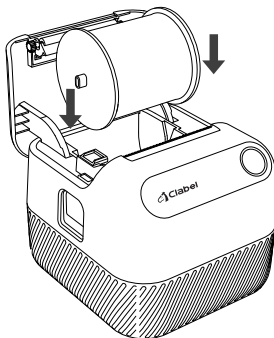

4、Place the label paper at right position.

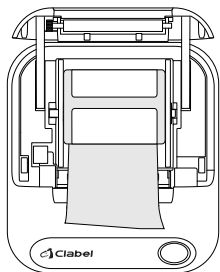

5、Close the paper case cover.

Press the case cover down-----

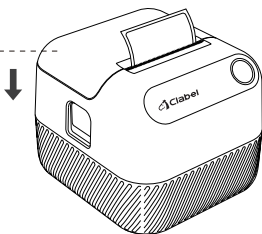

! When the register paper is printed, take the label shaft and baffle out, directly put into paper case, and follow steps 4~5.

4 KEY FUNCTION

Label mode

Preconditions	Power switch	Paper advance button	Function description
Nil	Turn to I	-	Startup
Nil	Turn to O	-	Shutdown
Being printed	-	Click	Printing suspended
Printing suspended	-	Click	Printing proceeded
Ready	-	Click	One piece of paper advanced
Ready	-	Keep pressing for 2 seconds	Paper test
Ready	-	Double-click	Printing self-inspection page
Machine is turned off	Then, turn to I	Firstly hold	Switch label/bill mode

Bill mode

Preconditions	Power switch	Paper advance button	Function description
Nil	Turn to I	-	Startup
Nil	Turn to O	-	Shutdown
Ready	-	Click	10 mm paper advance
Ready	-	Keep pressing	Continuous paper advance, stop immediately upon release.
Ready	-	Double-click	Printing self-inspection page
Machine is turned off	Then, turn to I	Firstly hold	Switch label/bill mode



DESCRIPTION OF INDICATOR LIGHTS

Standard version

Blue	Red	Indication status
Normally on	Quick flashing	Off
Quick flashing	Off	Over-temperature protection
Off	Normally on	Top cover opened/shortage of paper case

Bluetooth version

Blue	Red	Indication status
Slow flash	Off	Bluetooth unconnected
Normally on	Off	Bluetooth connected
Quick flashing	Off	Over-temperature protection
Off	Normally on	Top cover opened/shortage of paper case

 Indicator lights will slightly vary between different versions of printer.



SOFTWARE DOWNLOAD

iOS / Android

Scan the QR code below with a mobile phone to download “Clabel trade”.

Please operate the software following the software guidance.



Clabel trade



Download label editing app "Clabel trade" from Google Play Store or Apple APP Store and install it.

Window

Visit <https://ga.ctaiot.com/pc>

Download “Clabel trade” and driver.

Please check the software usage in the software help center



PRECAUTIONS

Precautions for use of the printer

- (1) The printer shall be installed at a steady location, away from vibration and impact.
- (2) DO NOT use or store the printer at any place with high temperature, high humidity or serious contamination.
- (3) Connect the power adapter of the printer to an appropriate grounding socket. DO NOT share the same socket with large motor or other equipment that may lead to voltage fluctuation of the power supply.
- (4) Strictly prevent water or conductive substances (i.e. metal) from entering into the printer. In case of any invasion, immediately shut off the power supply.
- (5) The printer must not work without paper, otherwise roller and thermo-sensitive print head may be seriously damaged.
- (6) Please shut off the power adapter if the printer will not be used for a long term.
- (7) The user must not disassemble the printer for maintenance or modification without authorization.
- (8) Only the power adapter delivered together with the printer can be used.
- (9) To ensure the printing quality and product life, it is advised to use high-quality paper.
- (10) Please assure that the printer is powered off, before plugging/ unplugging the connecting wire.
- (11) Power plug of the adapter is the power disconnection device. Its socket shall be installed nearby the equipment and easy to be accessed.
- (12) This product is applicable to tropical climatic conditions no higher than 5,000 above sea level only.

Printer cleaning

Under any of the following circumstances, the print head shall be promptly cleaned:

- (1) Printing is not clear.
- (2) Some column on the printed page is unclear.
- (3) It is noisy in the course of paper feeding.

Cleaning steps for print head are as follows:

- (1) Turn off the power supply, open the top cover and remove the paper if any.
- (2) If the printing is just finished, wait until the print head is cooled completely.
- (3) Remove dust and dirt on the surface of thermo-sensitive sheet of the print head with a soft cotton cloth with ethanol absolute (wrung out).
- (4) After complete volatilization of ethanol absolute, close the top cover and re-commission for printing

Cautions

- (1) Before routine maintenance, you must ensure that the printer is powered off.
- (2) DO NOT touch the surface of print head with your hand or metal. DO NOT use tweezers or such tools to scratch the surface of print head, roller and sensor.
- (3) DO NOT use gasoline, acetone or such organic solvent.
- (4) After complete volatilization of ethanol absolute, turn on the power and proceed with printing.

QUICK INSTALLATION GUIDE

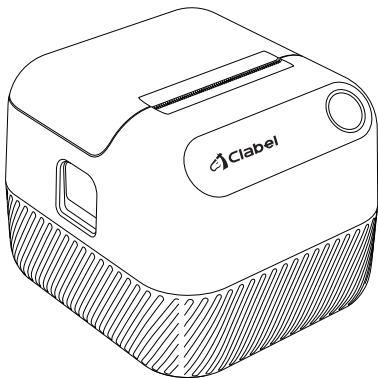

Shenzhen Dudian Technology Co., Ltd.

Room 1101, Building 3, COFCO Chuangzhi Factory Area, District 67,
Xingdong Community, Xin'an Street, Bao'an District, Shenzhen.
