

## TEST REPORT

**Report Number: 21111014HKG-001**

Application for Original Grant of 47 CFR Part 15 Certification

**FCC ID: 2A34XETAG4-5**

**Prepared and Checked by:**

**Approved by:**

Signed On File  
Wong Cheuk Ho, Herbert  
Lead Engineer

---

Wong Kwok Yeung, Kenneth  
Assistant Supervisor  
Date: December 13, 2021

## TEST REPORT

### GENERAL INFORMATION

<b>Applicant Name:</b>	Segoma LTD
<b>Applicant Address:</b>	Ha'Menofim10 Herzliya 4672561 Israel
<b>FCC Specification Standard:</b>	FCC Part 15, October 1, 2020 Edition
<b>FCC ID:</b>	<b>2A34XETAG4-5</b>
<b>FCC Model(s):</b>	4.5
<b>Type of EUT:</b>	Spread Spectrum Transmitter
<b>Description of EUT:</b>	Electronic Price Tag
<b>Serial Number:</b>	N/A
<b>Sample Receipt Date:</b>	November 19, 2021
<b>Date of Test:</b>	November 19, 2021 to December 06, 2021
<b>Report Date:</b>	December 13, 2021
<b>Environmental Conditions:</b>	Temperature: +10 to 40°C Humidity: 10 to 90%
<b>Conclusion:</b>	Test was conducted by client submitted sample. The submitted sample as received complied with the 47 CFR Part 15 Certification.

**TEST REPORT**

**TABLE OF CONTENTS**

**1.0 TEST RESULTS SUMMARY & STATEMENT OF COMPLIANCE ..... 4**

    1.1 Summary of Test Results.....4

    1.2 Statement of Compliance.....4

**2.0 GENERAL DESCRIPTION..... 5**

    2.1 Product Description .....5

    2.2 Test Methodology .....5

    2.3 Test Facility .....5

    2.4 Related Submittal(s) Grants .....5

**3.0 SYSTEM TEST CONFIGURATION..... 6**

    3.1 Justification .....6

    3.2 EUT Exercising Software.....7

    3.3 Details of EUT and Description of Accessories.....8

    3.4 Measurement Uncertainty .....8

**4.0 TEST RESULTS ..... 9**

    4.1 Maximum Conducted Output Power at Antenna Terminals .....9

    4.2 Minimum 6dB RF Bandwidth.....10

    4.3 Maximum Power Spectral Density .....15

    4.4 Out of Band Conducted Emissions .....20

    4.5 Field Strength Calculation.....29

    4.6 Transmitter Radiated Emissions in Restricted Bands and Spurious Emissions.....30

        4.6.1 Radiated Emission Configuration Photograph.....30

        4.6.2 Radiated Emission Data.....30

        4.6.3 Radiated Emission Test Setup.....38

        4.6.4 Transmitter Duty Cycle Calculation .....39

    4.7 AC Power Line Conducted Emission .....40

**5.0 EQUIPMENT LIST ..... 41**

## TEST REPORT

### 1.0 TEST RESULTS SUMMARY & STATEMENT OF COMPLIANCE

#### 1.1 Summary of Test Results

Test Items	FCC Part 15 Section	Results	Details See Section
Antenna Requirement	15.203	Pass	2.1
Max. Conducted Output Power (Peak)	15.247(b)(3)&(4)	Pass	4.1
Min. 6dB RF Bandwidth	15.247(a)(2)	Pass	4.2
Max. Power Density (average)	15.247(e)	Pass	4.3
Out of Band Antenna Conducted Emission	15.247(d)	Pass	4.4
Radiated Emission in Restricted Bands and Spurious Emissions	15.247(d), 15.209 & 15.109	Pass	4.6
AC Power Line Conducted Emission	15.207 & 15.107	Pass	4.7

Note: Pursuant to FCC Part 15 Section 15.215(c), the 20dB bandwidth of the emission was contained within the frequency band designated (mentioned as above) which the EUT operated. The effects, if any, from frequency sweeping, frequency hopping, other modulation techniques and frequency stability over expected variations in temperature and supply voltage were considered.

#### 1.2 Statement of Compliance

The equipment under test is found to be complying with the following standard:

FCC Part 15, October 1, 2020 Edition

## TEST REPORT

### 2.0 GENERAL DESCRIPTION

#### 2.1 Product Description

The Model: 4.5 is Electronic Price Tag with Bluetooth BLE feature.

The Equipment Under Test (EUT) operates at frequency range of 2402MHz to 2480MHz with 1Mbit and 2Mbit data rate.

The EUT is power by 3.0VDC (1 x 3.0V "CR2032" Battery).

The antenna(s) used in the EUT is integral, and the test sample is a prototype.

The circuit description is saved with filename: descri.pdf.

#### 2.2 Test Methodology

Radiated emission measurements were performed according to the procedures in ANSI C63.10 (2013). Preliminary radiated scans and all radiated measurements were performed in radiated emission test sites. All Radiated tests were performed at an antenna to EUT distance of 3 meters, unless stated otherwise in the "**Justification Section**" of this Application. Antenna port conducted measurements were performed according to ANSI C63.10 (2013) and KDB Publication No.558074 D01 v05r01 (11-February-2019). All other measurements were made in accordance with the procedures in 47 CFR Part 2.

#### 2.3 Test Facility

The radiated emission test site and antenna port conducted measurement facility used to collect the radiated data and conductive data are at Workshop No. 3, G/F., World-Wide Industrial Centre, 43-47 Shan Mei Street, Fo Tan, Sha Tin, N.T., Hong Kong SAR, China. This test facility and site measurement data have been fully placed on file with the FCC.

#### 2.4 Related Submittal(s) Grants

This is a single application for certification of a transceiver (Bluetooth BLE portion)

## TEST REPORT

### 3.0 SYSTEM TEST CONFIGURATION

#### 3.1 Justification

For radiated emissions testing, the equipment under test (EUT) was setup to transmit / receive continuously to simplify the measurement methodology. Care was taken to ensure proper power supply voltages during testing. During testing, all cables (if any) were manipulated to produce worst case emissions.

The EUT was powered by 3.0VDC (1 x new 3.0V "CR2032" Battery).

For the measurements, the EUT was attached to a plastic stand if necessary and placed on the wooden turntable. If the base unit attached to peripherals, they were connected and operational (as typical as possible).

The signal was maximized through rotation and placement in the three orthogonal axes. The antenna height and polarization were varied during the search for maximum signal level. The antenna height was varied from 1 to 4 meters. Radiated emissions were taken at three meters unless the signal level was too low for measurement at that distance. If necessary, a pre-amplifier was used and/or the test was conducted at a closer distance.

For any intentional radiator powered by AC power line, measurements of the radiated signal level of the fundamental frequency component of the emission was performed with the supply voltage varied between 85% and 115% of the nominal rated supply voltage.

Radiated emission measurement for transmitter were performed from the lowest radio frequency signal generated in the device which is greater than 9 kHz to the tenth harmonic of the highest fundamental frequency or to 40 GHz, whichever is lower.

Emission that are directly caused by digital circuits in the transmit path and transmitter portion were measured, and the limit are according to FCC Part 15 Section 15.209. Digital circuitries used to control additional functions other than the operation of the transmitter are subject to FCC Part 15 Section 15.109 Limits.

## TEST REPORT

### 3.1 Justification – Cont'd

Detector function for radiated emissions was in peak mode. Average readings, when required, were taken by measuring the duty cycle of the equipment under test and subtracting the corresponding amount in dB from the measured peak readings. A detailed description for the calculation of the average factor can be found in section 4.8.3.

Determination of pulse desensitization was made according to *Hewlett Packard Application Note 150-2, Spectrum Analysis... Pulsed RF*. The effective period (Teff) was referred to Exhibit 4.8.3. With the resolution bandwidth 1MHz and spectrum analyzer IF bandwidth 3dB, the pulse desensitization factor was 0dB.

For AC line conducted emission test, the EUT along with its peripherals were placed on a 1.0m(W)x1.5m(L) and 0.8m in height wooden table and the EUT was adjusted to maintain a 0.4 meter space from a vertical reference plane. The EUT was connected to power mains through a line impedance stabilization network (LISN), which provided 50ohm coupling impedance for measuring instrument. The LISN housing, measuring instrument case, reference ground plane, and vertical ground plane were bounded together. The excess power cable between the EUT and the LISN was bundled.

All connecting cables of EUT and peripherals were manipulated to find the maximum emission.

Different data rates have been tested. Worst case is reported only.

All relevant operation modes have been tested, and the worst-case data is included in this report.

### 3.2 EUT Exercising Software

The EUT exercise program (if any) used during radiated and conducted testing was designed to exercise the various system components in a manner similar to a typical use.

## TEST REPORT

### 3.3 Details of EUT and Description of Accessories

Details of EUT:

The EUT is power by 3.0VDC (1 x 3.0V "CR2032" Battery).

Description of Accessories:

N/A

There are no accessories for compliance of this product.

### 3.4 Measurement Uncertainty

Decision Rule for compliance: For FCC/IC standard, the measured value must be within the limits of applicable standard without accounting for the measurement uncertainty. For EN/IEC/HKTA/HKTC standard, conformity rules will be used as per standard directly excepted EN/IEC 61000-3-2, EN/IEC 61000-3-3, HKTA1004, HKCA1008, HKTA1019, HKTA1020, HKTA1041 and HKTA1044. For these excepted or not mentioned standards, Cl 4.2.2 of ILAC-G8:09/2019 decision rules will be reference and guard band will be equal to our measurement uncertainty with 95% confidence level (k=2). In case, the measured value is within guard band region, undetermined decision will be used. The values of the Measurement uncertainty for radiated emission test and RF conducted measurement test are  $\pm 5.3\text{dB}$  and  $\pm 0.99\text{dB}$  respectively. The value of the Measurement uncertainty for conducted emission test is  $\pm 4.2\text{dB}$ .

Uncertainty and Compliance - Unless the standard specifically states that measured values are to be extended by the measurement uncertainty in determining compliance, all compliance determinations are based on the actual measured value.



**TEST REPORT**

**4.0 TEST RESULTS**

4.1 Maximum Conducted (peak) Output Power at Antenna Terminals

RF Conduct Measurement Test Setup

The figure below shows the test setup, which is utilized to make these measurements.

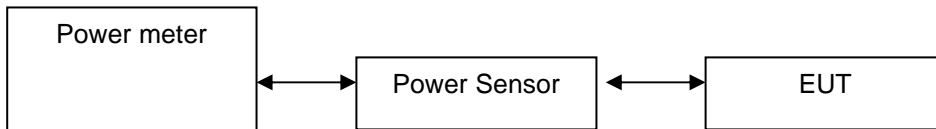

The antenna port of the EUT was connected to the input of a spectrum analyzer.

- The antenna power of the EUT was connected to the input of a power meter. Power was read directly and cable loss correction was added to the reading to the obtain power at the EUT antenna terminals. The measurement procedure 9.1.2 was used.
- The EUT should be configured to transmit continuously (at a minimum duty cycle of 98%) at full power over the measurement duration. The measurement procedure AVG1 was used.

BT4 1Mbit Antenna Gain = 2.0 dBi

Frequency (MHz)	Output in dBm	Output in mWatt
Low Channel: 2402	6.2	4.2
Middle Channel: 2440	5.8	3.8
High Channel: 2480	4.6	2.9

BT4 2Mbit (Antenna Gain = 2.0 dBi)

Frequency (MHz)	Output in dBm	Output in mWatt
Low Channel: 2402	6.2	4.2
Middle Channel: 2440	6.0	4.0
High Channel: 2480	3.8	2.4

Cable loss : 0.5 dB External Attenuation : 0 dB

Cable loss, external attenuation:  included in OFFSET function  
 added to SA raw reading

BT4 1Mbit  
max. conducted (peak) output level = 6.2 dBm

BT4 2Mbit  
max. conducted (peak) output level = 6.2 dBm

- Limits:
- 1W (30dBm) for antennas with gains of 6dBi or less
  - \_\_\_W (\_\_\_dBm) for antennas with gains more than 6dBi

**TEST REPORT**

4.2 Minimum 6dB RF Bandwidth

The antenna port of the EUT was connected to the input of a spectrum analyzer. The EBW measurement procedure was used. A PEAK output reading was taken, a DISPLAY line was drawn 6dB lower than PEAK level. The 6dB bandwidth was determined from where the channel output spectrum intersected the display line.

BT4 1Mbit

Frequency (MHz)	6dB Bandwidth (MHz)
Low Channel: 2402	0.780
Middle Channel: 2440	0.780
High Channel: 2480	0.760

BT4 2Mbit

Frequency (MHz)	6dB Bandwidth (MHz)
Low Channel: 2402	1.30
Middle Channel: 2440	1.30
High Channel: 2480	1.44

Limits

6 dB bandwidth shall be at least 500kHz

The plots of 6dB RF bandwidth are saved as below.

**TEST REPORT**

**PLOTS OF 6dB RF BANDWIDTH**

BT4 1Mbit, Lowest Channel

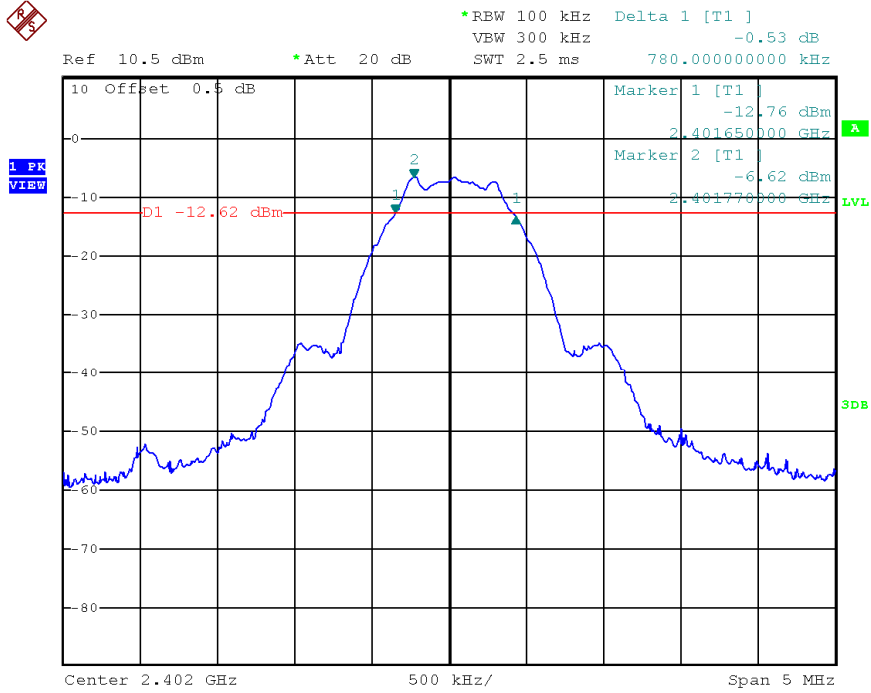

BT4 1Mbit, Middle Channel

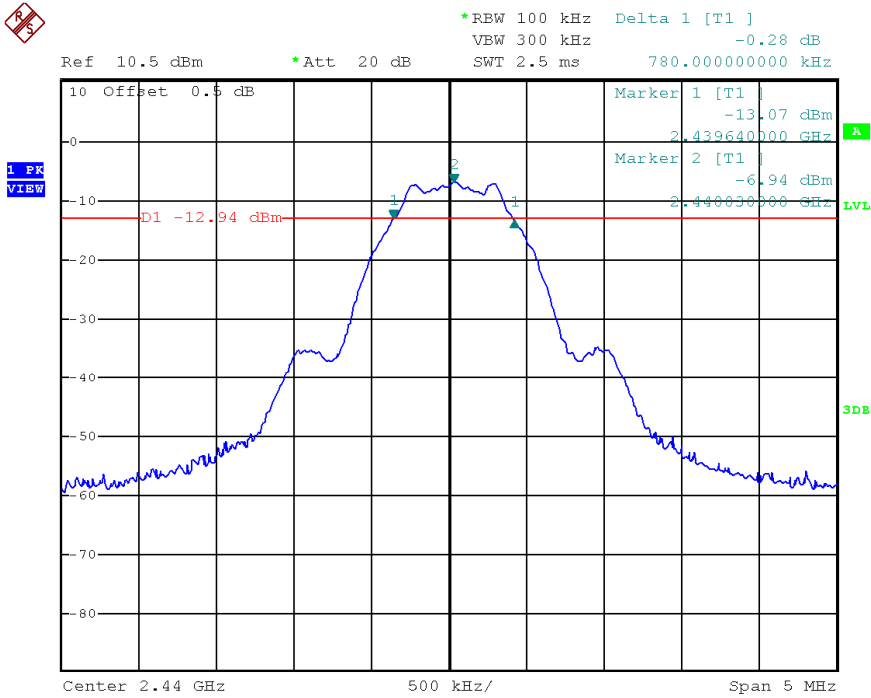

**TEST REPORT**

**PLOTS OF 6dB RF BANDWIDTH**

BT4 1Mbit, Highest Channel

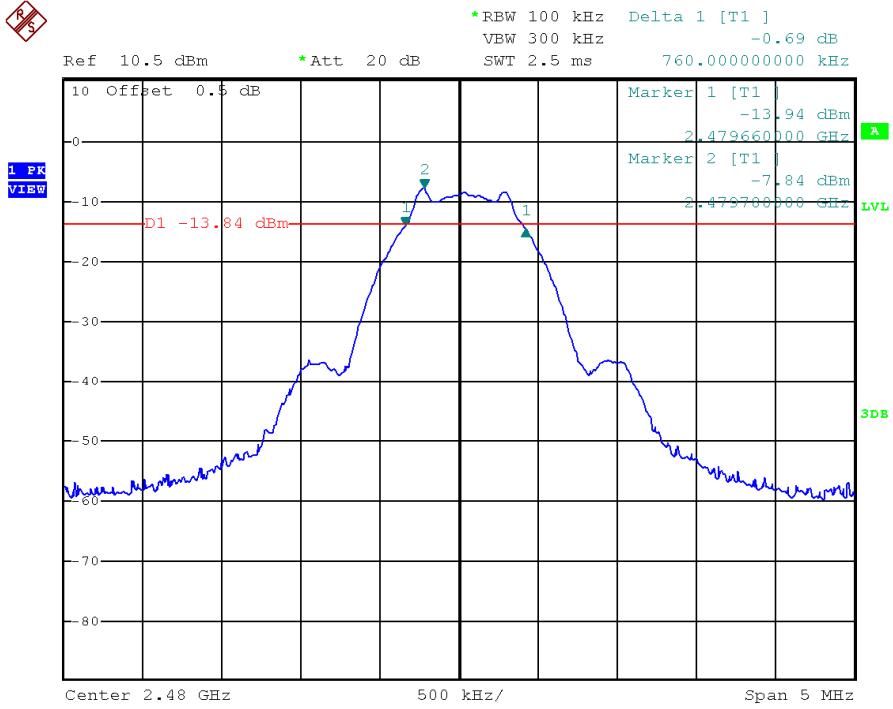

**TEST REPORT**

**PLOTS OF 6dB RF BANDWIDTH**

**BT4 2Mbit, Lowest Channel**

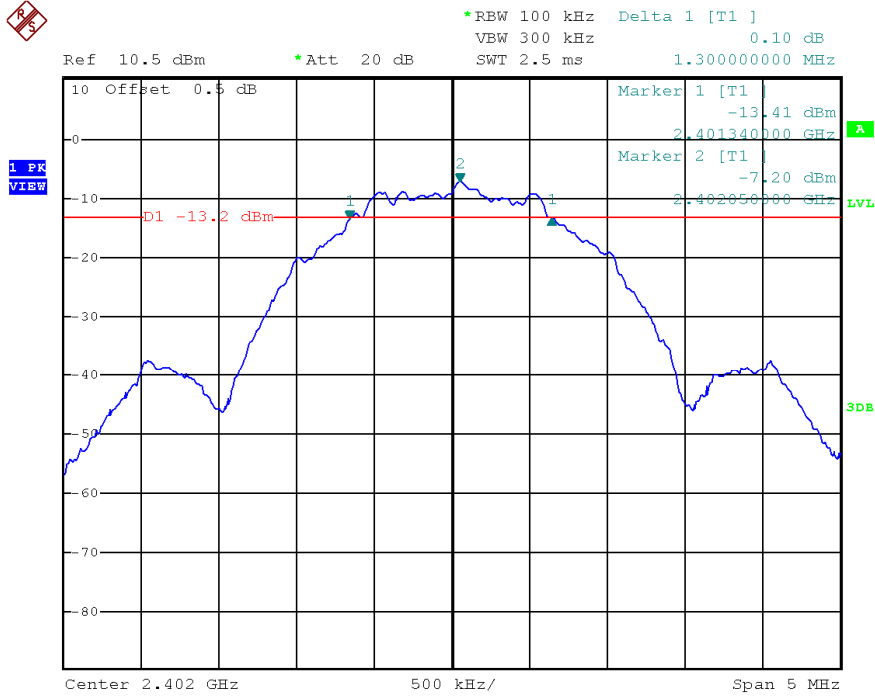

**BT4 2Mbit, Middle Channel**

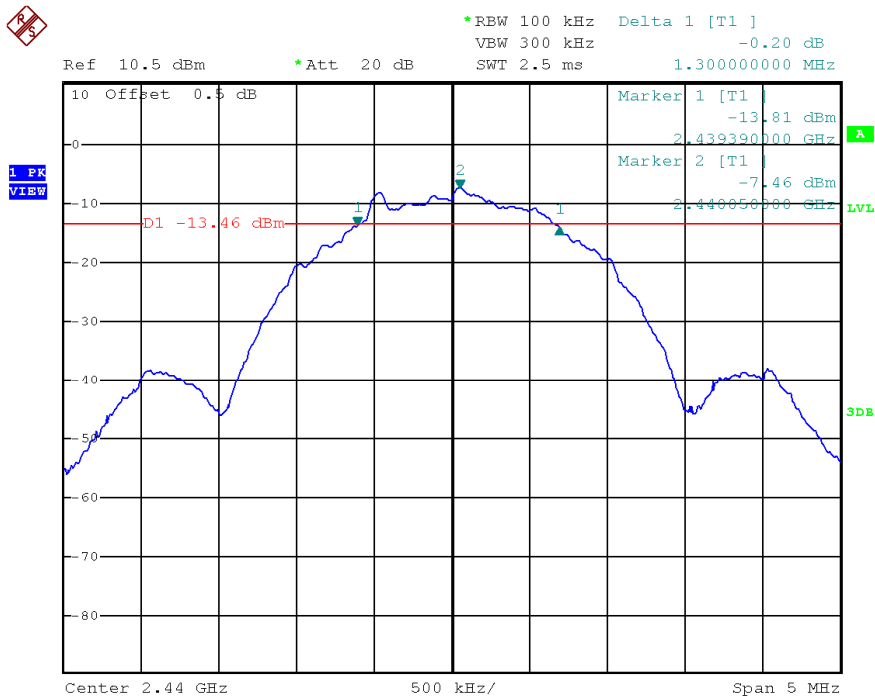

**TEST REPORT**

**PLOTS OF 6dB RF BANDWIDTH**

BT4 2Mbit, Highest Channel

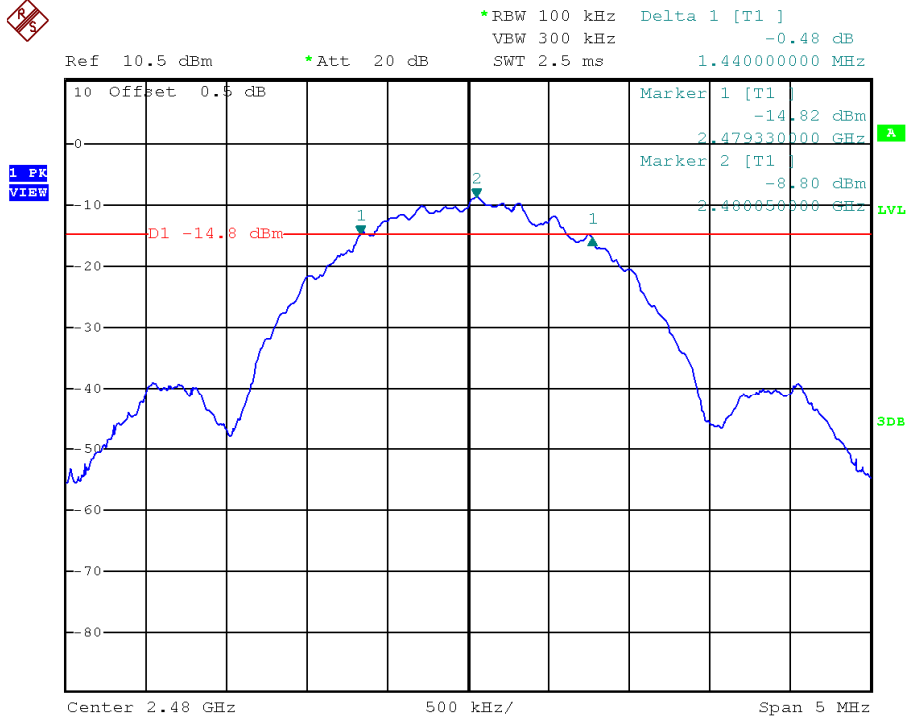

**TEST REPORT**

4.3 Maximum Power Spectral Density

Antenna output of the EUT was coupled directly to spectrum analyzer. The measurement procedure 10.2 PKPSD was used. If an external attenuator and/or cable was used, these losses are compensated for using the OFFSET function of the analyser.

BT4 1Mbit

Frequency (MHz)	PSD in 100kHz (dBm)
Low Channel: 2402	-6.35
Middle Channel: 2440	-6.95
High Channel: 2480	-7.86

BT4 2Mbit

Frequency (MHz)	PSD in 100kHz (dBm)
Low Channel: 2402	-7.26
Middle Channel: 2440	-7.52
High Channel: 2480	-8.74

Cable Loss: 0.5 dB

Limit:  
8dBm

The plots of power spectral density are as below.

**TEST REPORT**

**PLOTS OF POWER SPECTRAL DENSITY**

BT4 1Mbit, Lowest channel

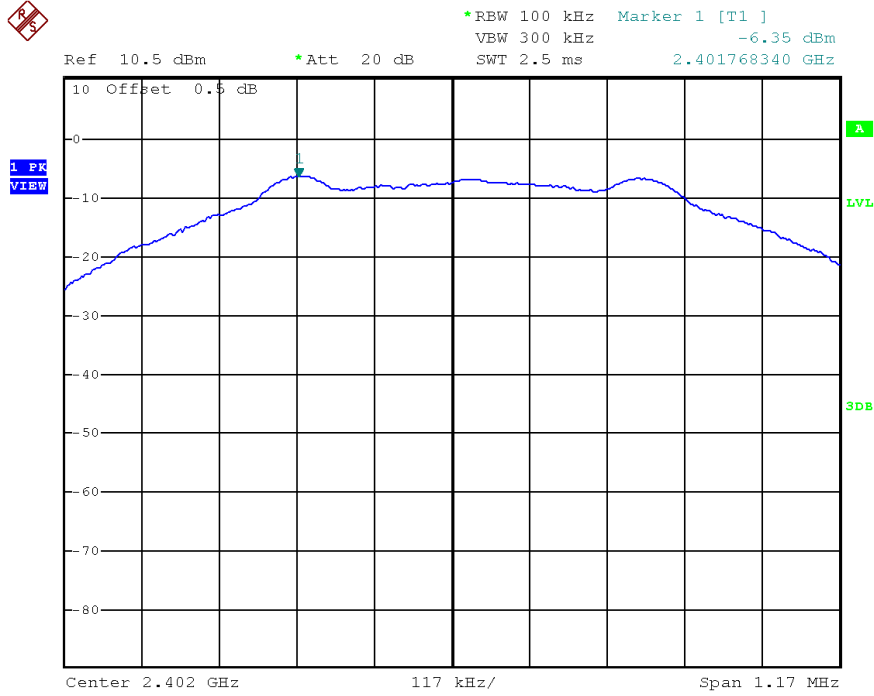

BT4 1Mbit, Middle channel

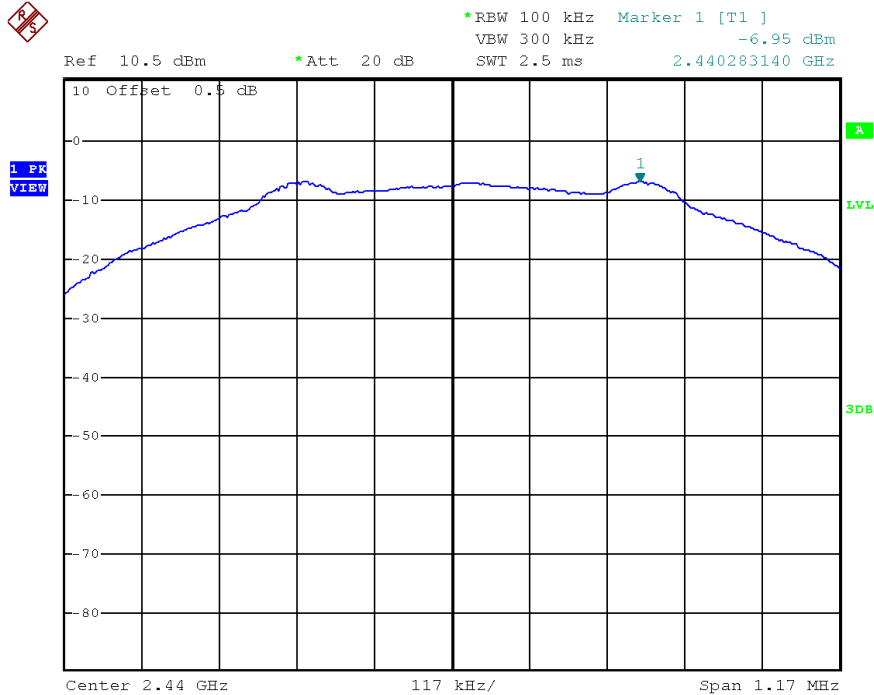



### TEST REPORT

### PLOTS OF POWER SPECTRAL DENSITY

BT4 1Mbit, Highest channel

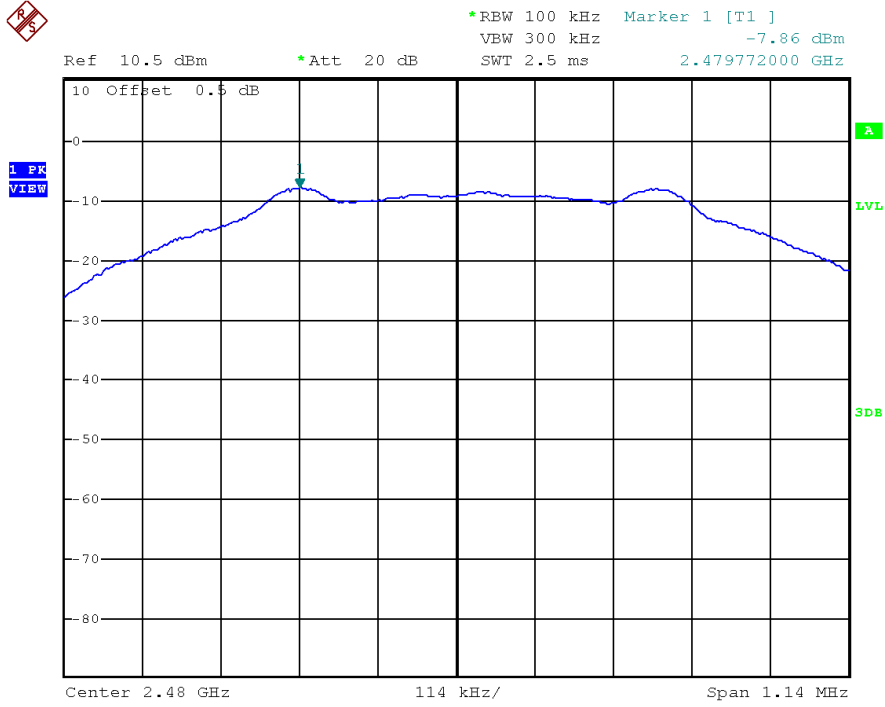

**TEST REPORT**

**PLOTS OF POWER SPECTRAL DENSITY**

BT4 2Mbit, Lowest channel

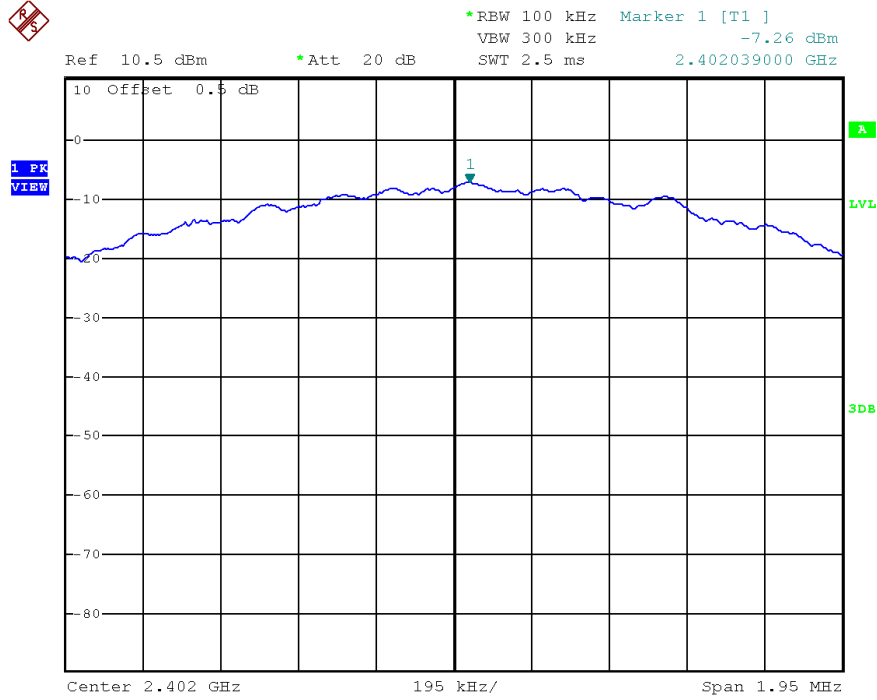

BT4 2Mbit, Middle channel

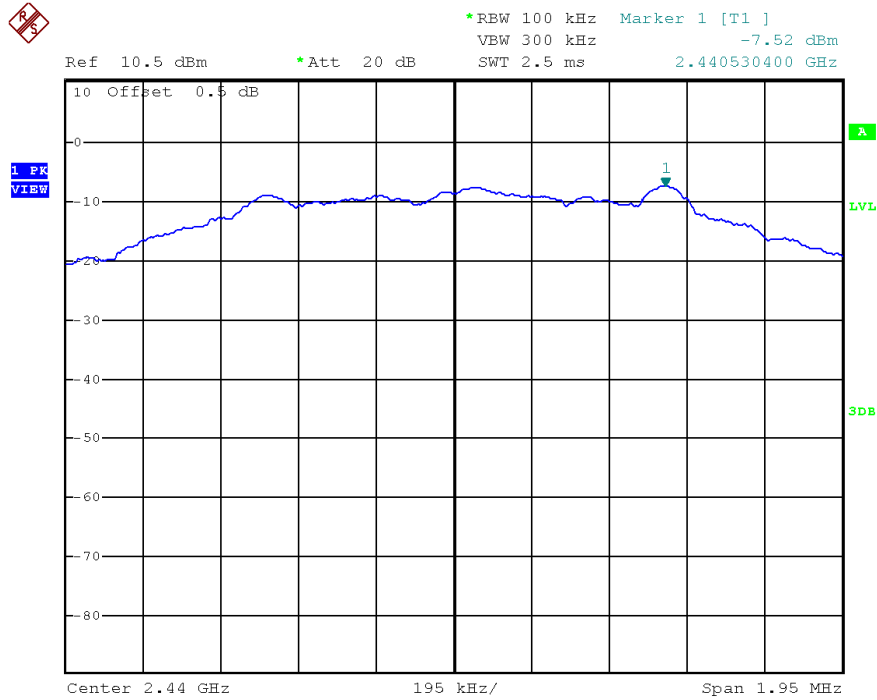

**TEST REPORT**

**PLOTS OF POWER SPECTRAL DENSITY**

BT4 2Mbit, Highest channel

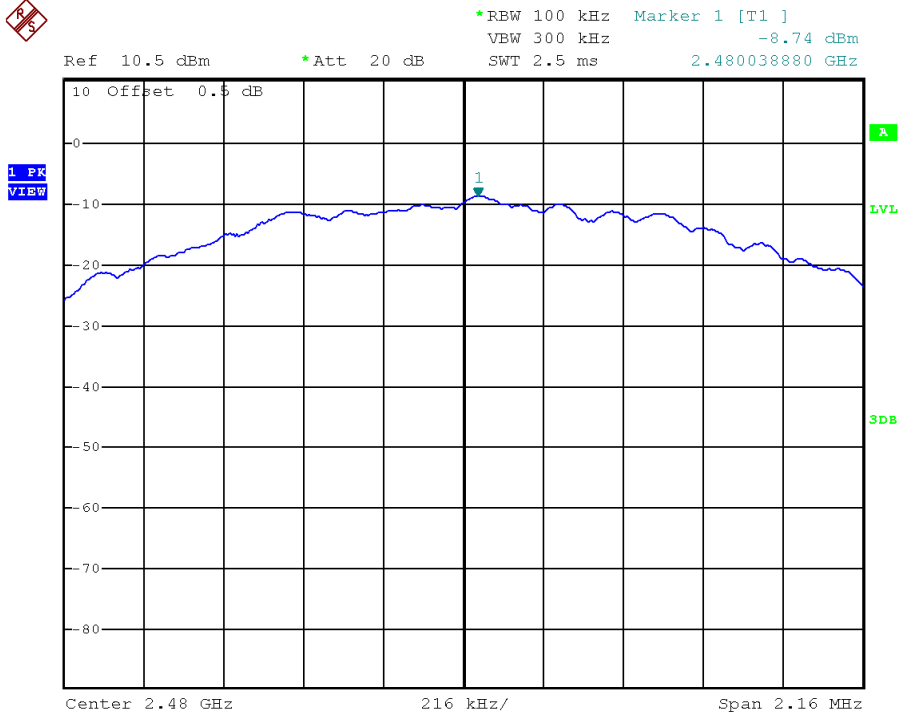

## TEST REPORT

### 4.4 Out of Band Conducted Emissions

For BT4 1Mbit/ BT4 2Mbit, the maximum conducted (peak) output power was used to demonstrate compliance as described in 9.1. Then the display line (in red) shown in the following plots denotes the limit at 20dB below maximum measured in-band peak PSD level in 100 KHz bandwidth for BT4 1Mbit/ BT4 2Mbit.

The measurement procedures under sections 11 of KDB558074 D01 v05r01 (11-February-2019) were used.

Furthermore, delta measurement technique for measuring bandedge emissions was incorporated in the test of the edge at 2483.5MHz.

#### Limits:

All spurious emission and up to the tenth harmonic was measured and they were found to be at least 20dB below the maximum measured in-band peak PSD level.

**TEST REPORT**

**PLOTS OF OUT OF BAND CONDUCTED EMISSIONS**

BT4 1Mbit, Lowest Channel, Bandedge

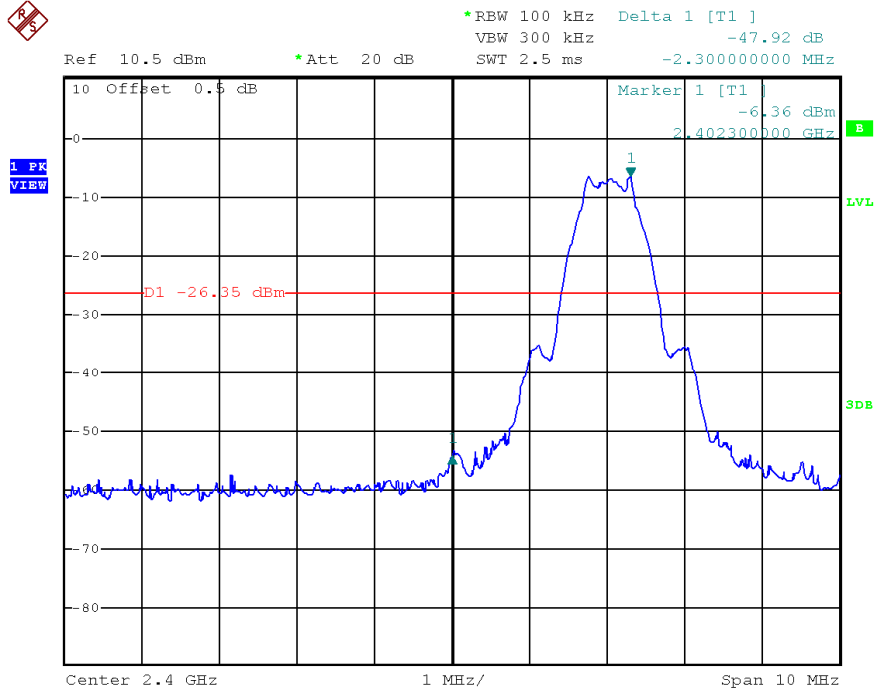

BT4 1Mbit, Highest Channel, Bandedge

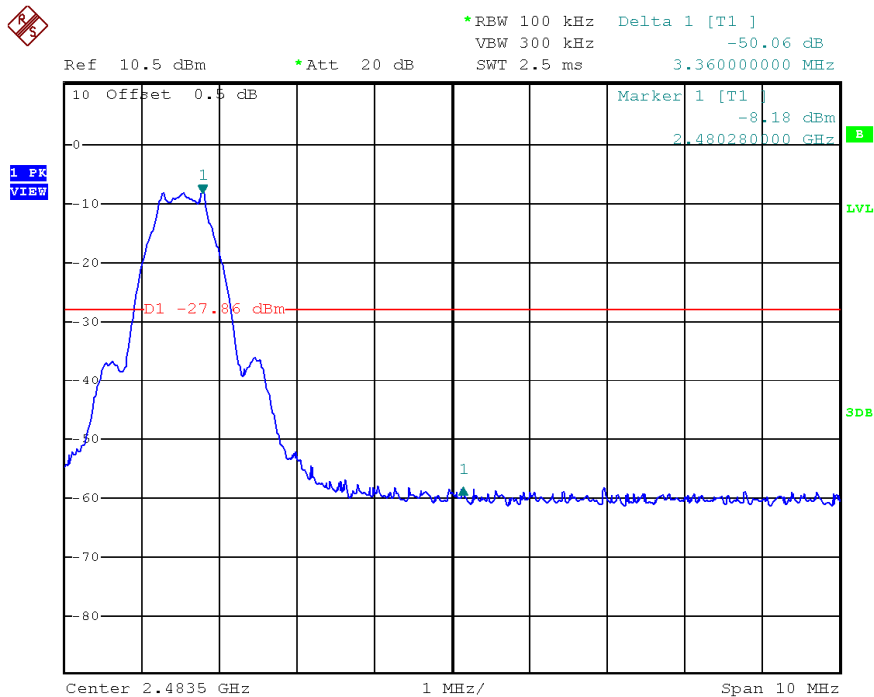

**TEST REPORT**

**PLOTS OF OUT OF BAND CONDUCTED EMISSIONS**

**BT4 1Mbit, Lowest Channel, Plot A**

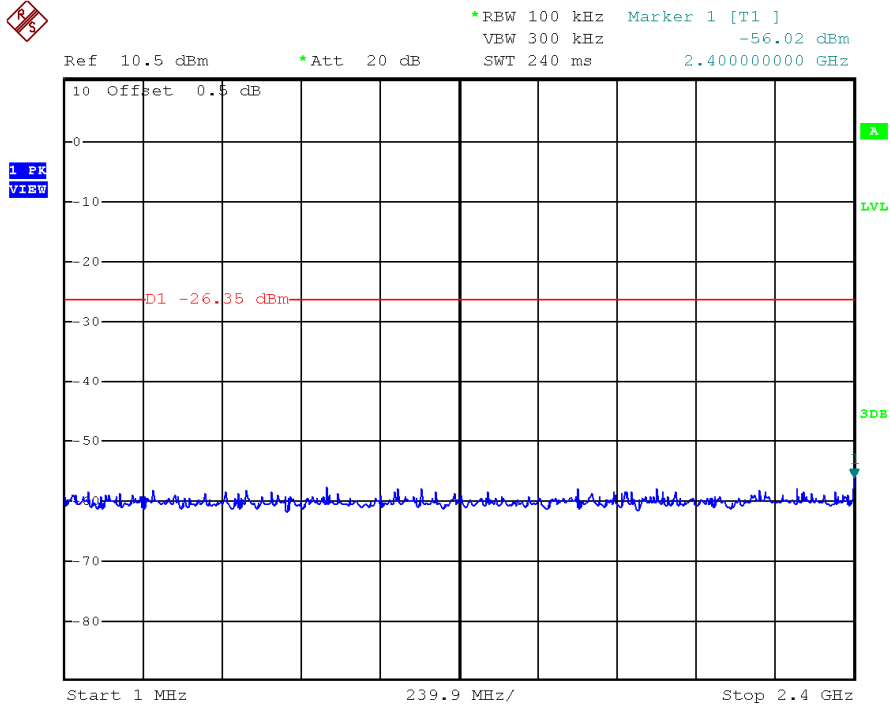

**BT4 1Mbit, Lowest Channel, Plot B**

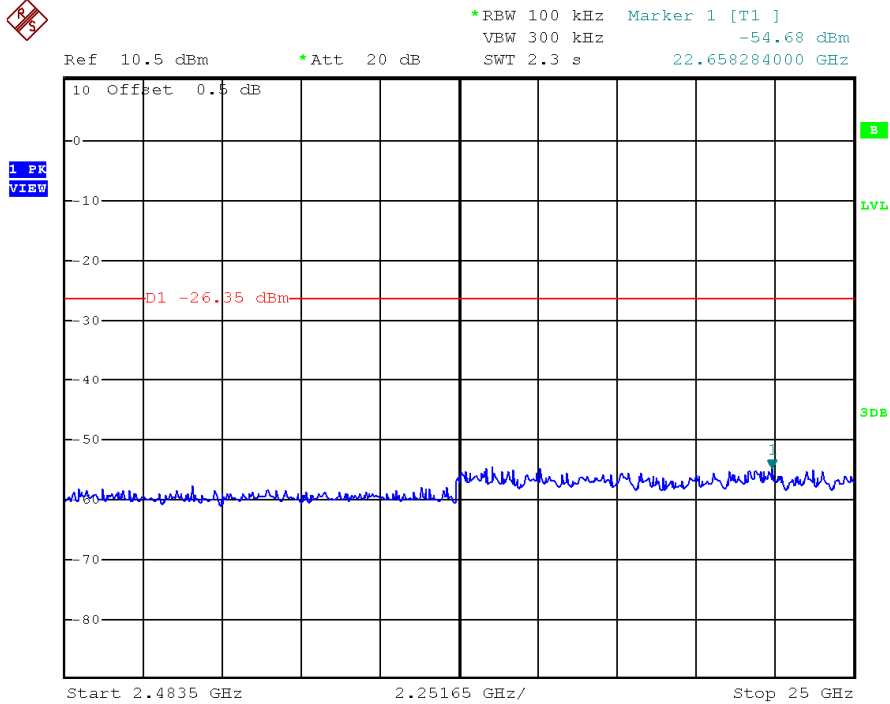

**TEST REPORT**

**PLOTS OF OUT OF BAND CONDUCTED EMISSIONS**

**BT4 1Mbit, Middle Channel, Plot A**

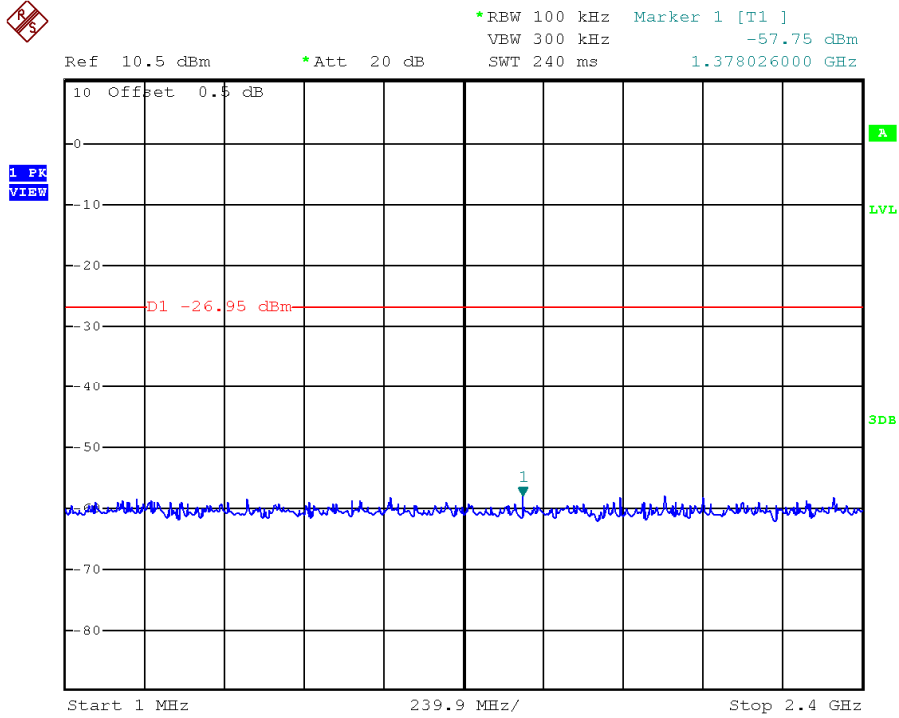

**BT4 1Mbit, Middle Channel, Plot B**

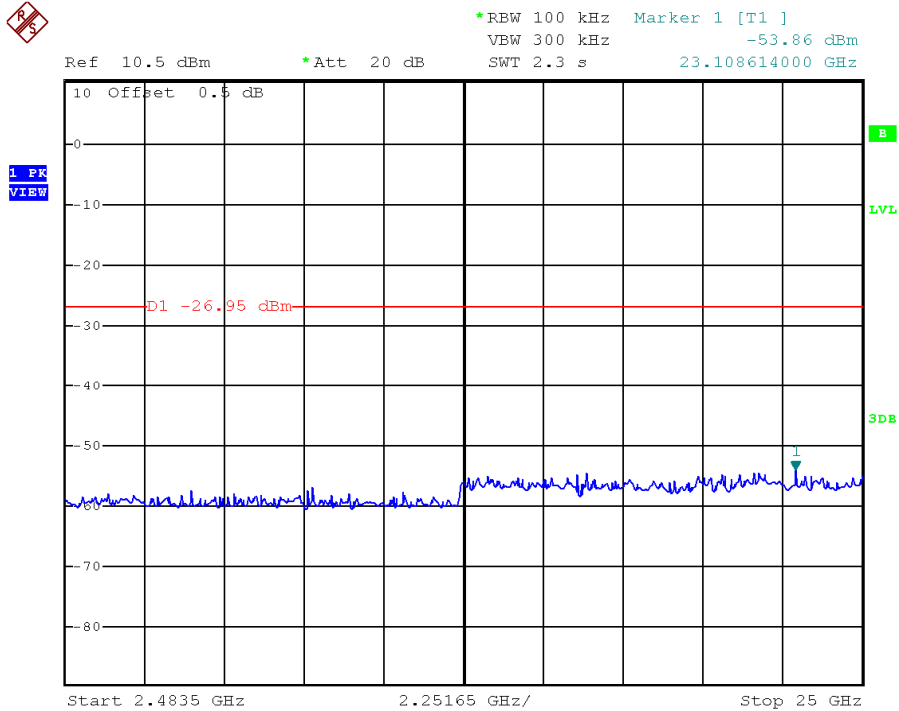

**TEST REPORT**

**PLOTS OF OUT OF BAND CONDUCTED EMISSIONS**

**BT4 1Mbit, Highest Channel, Plot A**

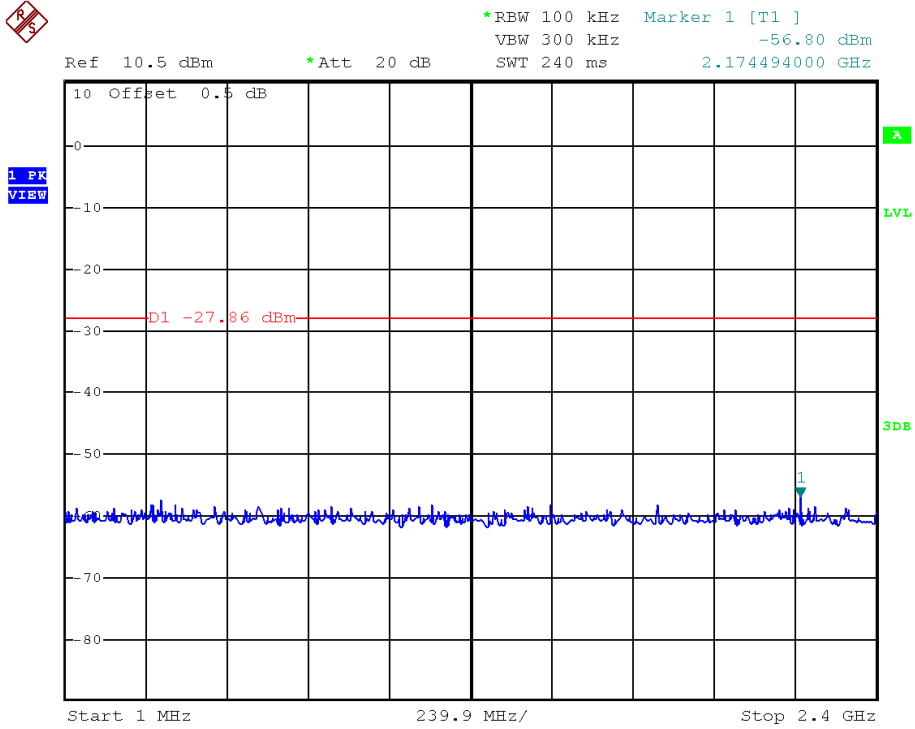

**BT4 1Mbit, Highest Channel, Plot B**

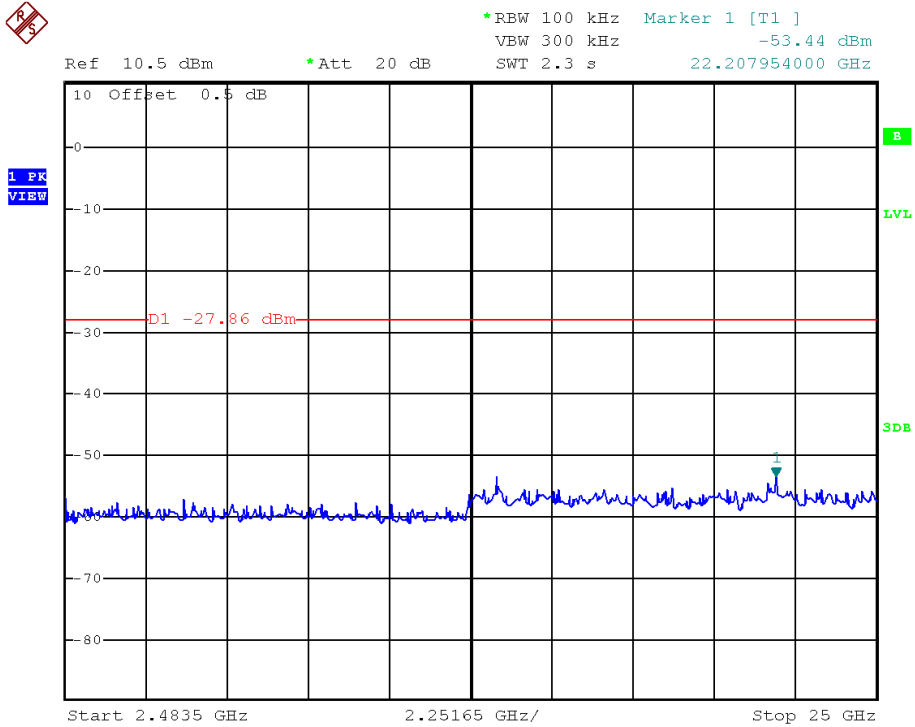



**TEST REPORT**

**PLOTS OF OUT OF BAND CONDUCTED EMISSIONS**

**BT4 2Mbit, Lowest Channel, Bandedge**

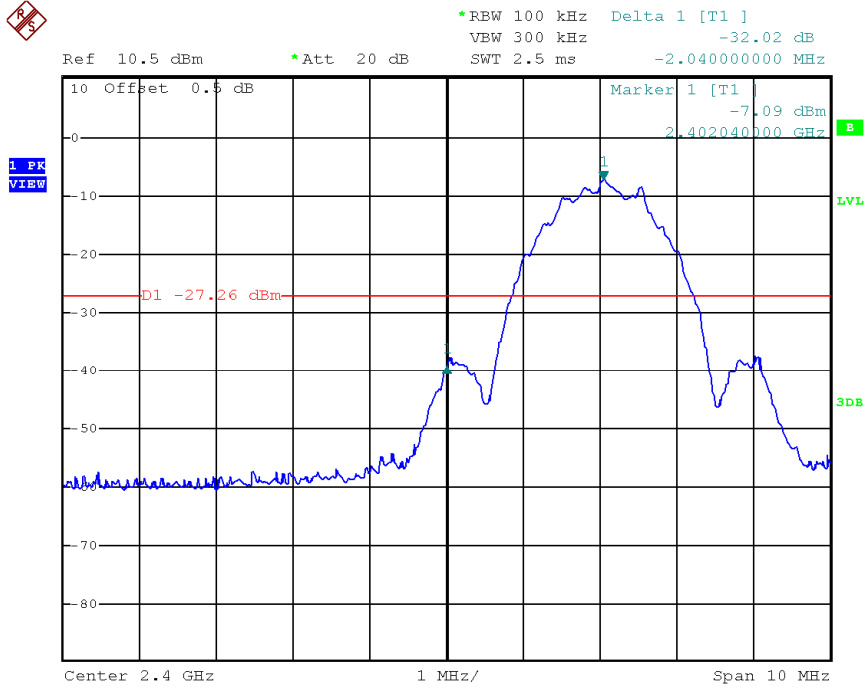

**BT4 2Mbit, Highest Channel, Bandedge**

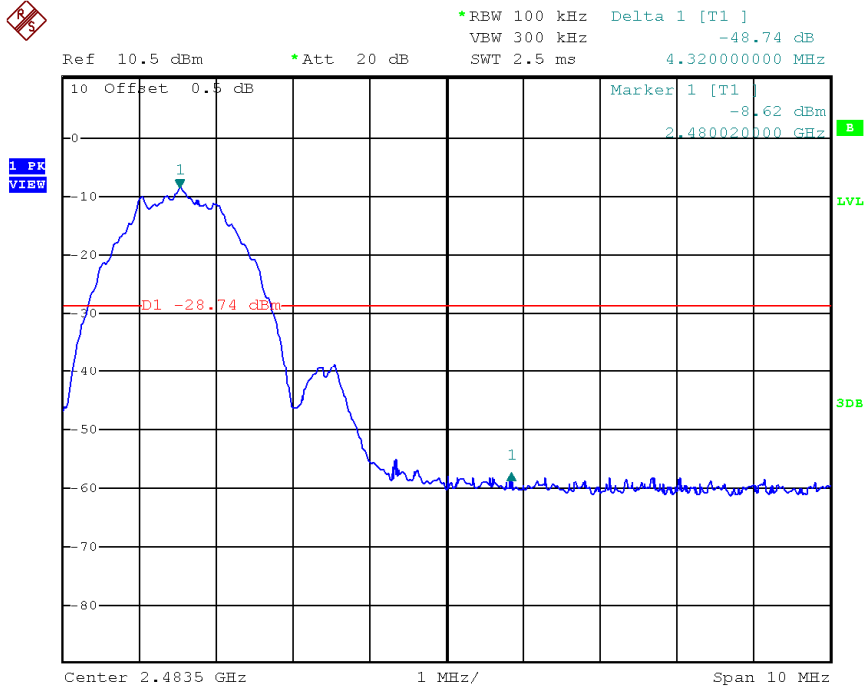

**TEST REPORT**

**PLOTS OF OUT OF BAND CONDUCTED EMISSIONS**

**BT4 2Mbit, Lowest Channel, Plot A**

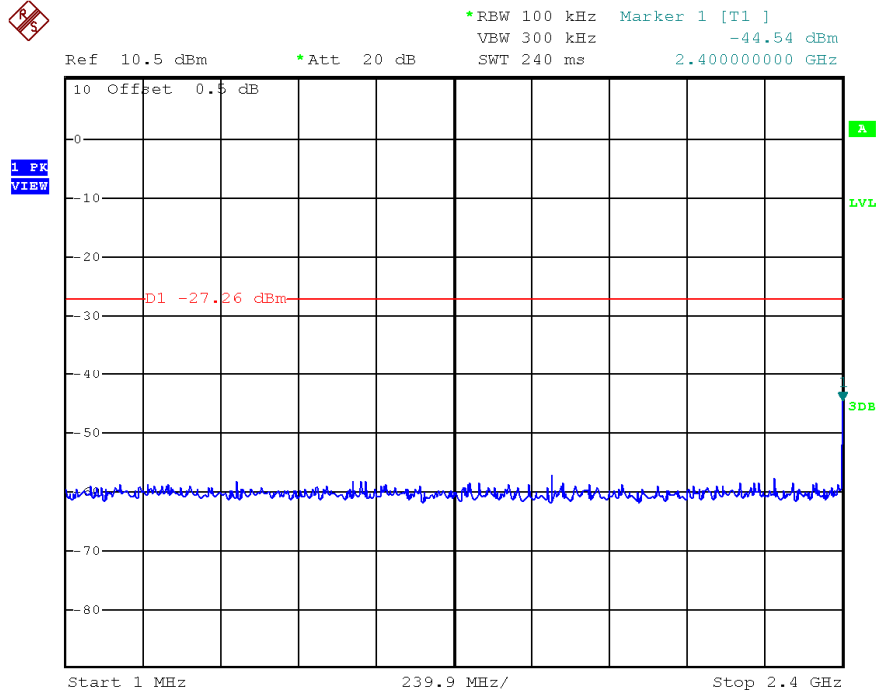

**BT4 2Mbit, Lowest Channel, Plot B**

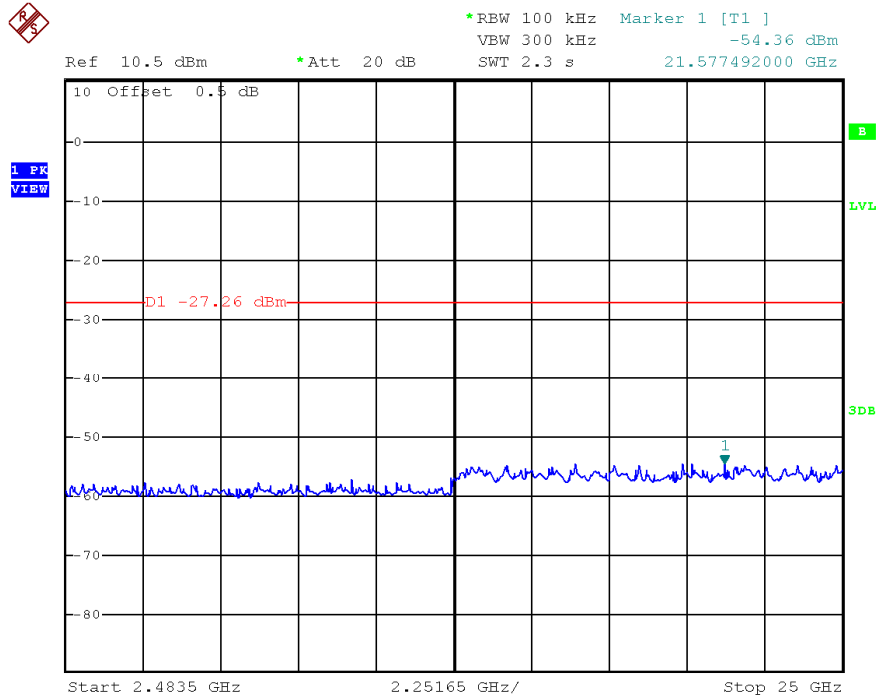

**TEST REPORT**

**PLOTS OF OUT OF BAND CONDUCTED EMISSIONS**

**BT4 2Mbit, Middle Channel, Plot A**

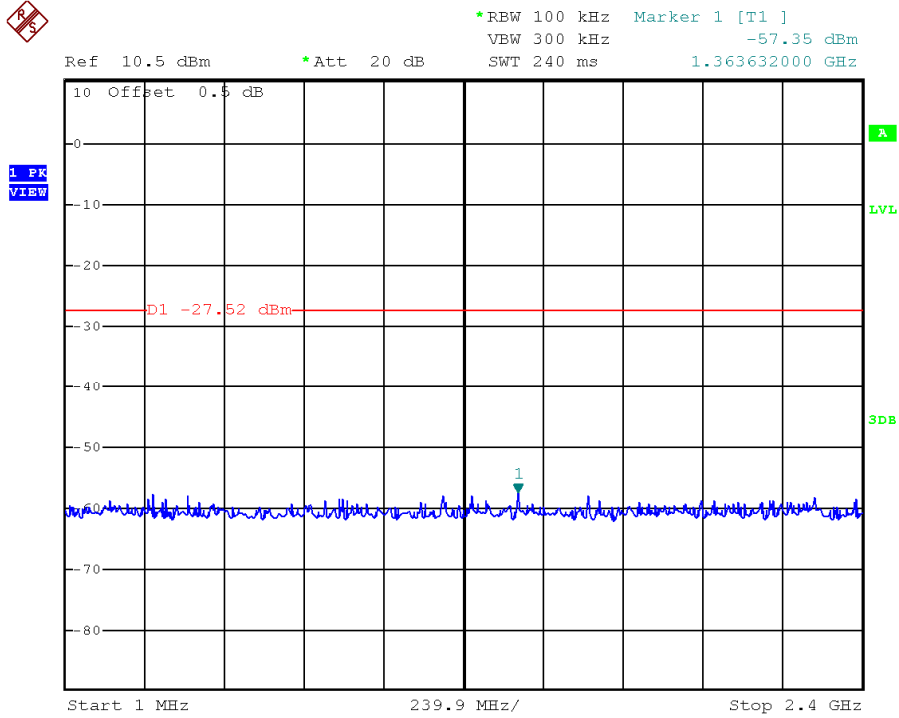

**BT4 2Mbit, Middle Channel, Plot B**

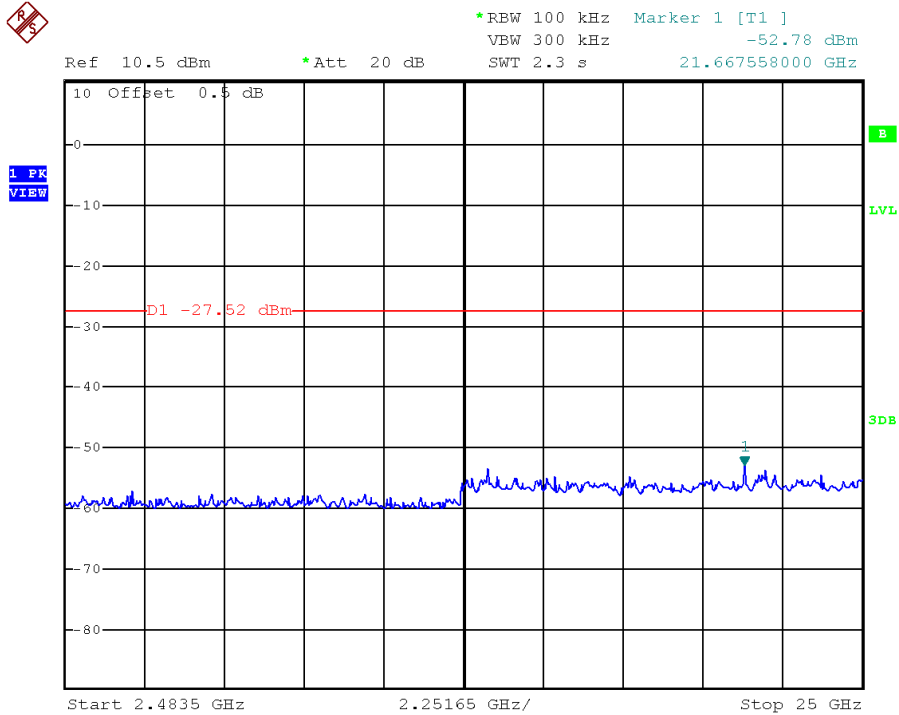

**TEST REPORT**

**PLOTS OF OUT OF BAND CONDUCTED EMISSIONS**

**BT4 2Mbit, Highest Channel, Plot A**

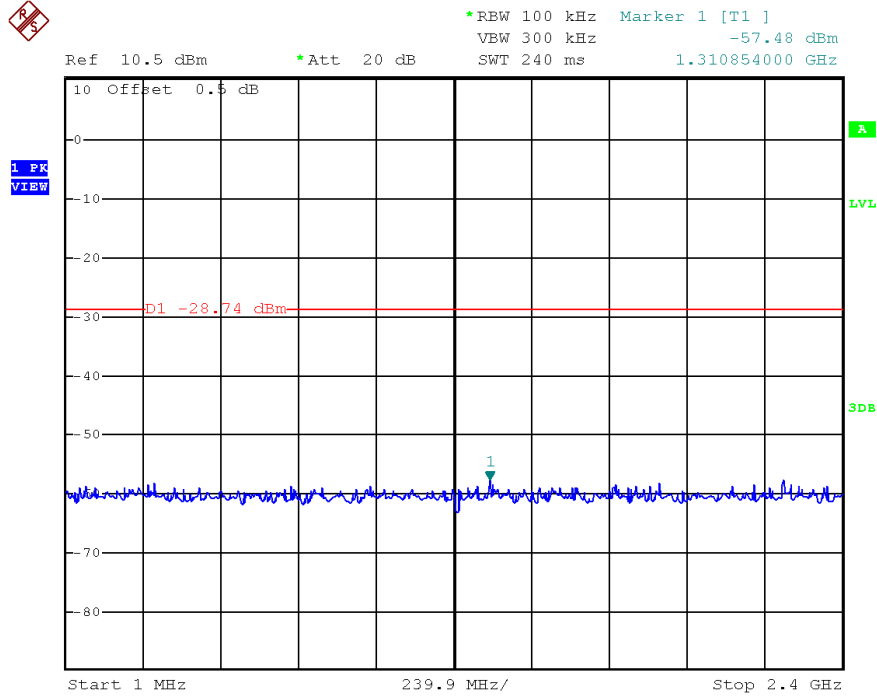

**BT4 2Mbit, Highest Channel, Plot B**

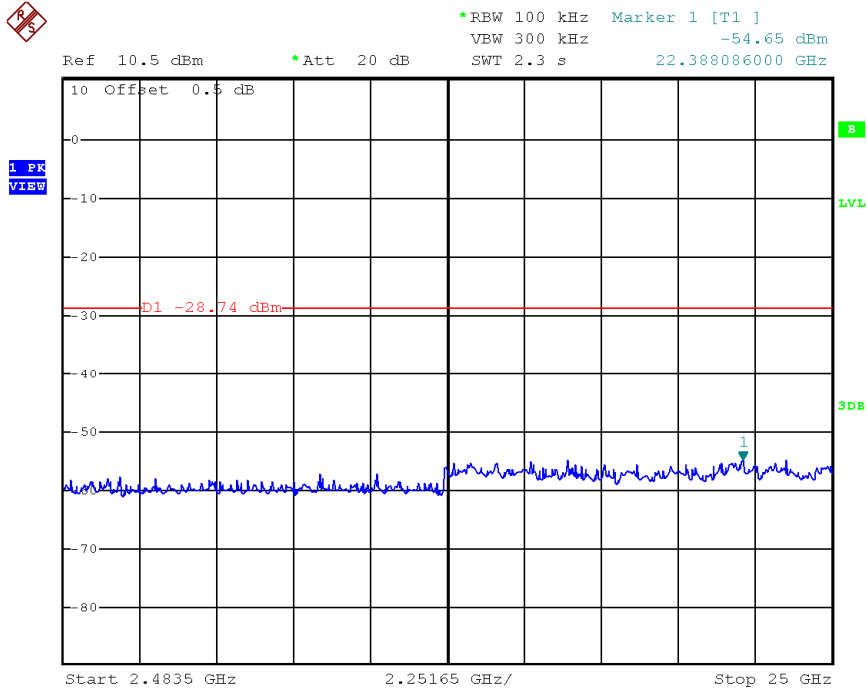

## TEST REPORT

### 4.5 Field Strength Calculation

The field strength is calculated by adding the reading on the Spectrum Analyzer to the factors associated with preamplifiers (if any), antennas, cables, pulse desensitization and average factors (when specified limit is in average and measurements are made with peak detectors). A sample calculation is included below.

$$FS = RA + AF + CF - AG + PD + AV$$

Where FS = Field Strength in dB $\mu$ V/m

RA = Receiver Amplitude (including preamplifier) in dB $\mu$ V

CF = Cable Attenuation Factor in dB

AF = Antenna Factor in dB

AG = Amplifier Gain in dB

PD = Pulse Desensitization in dB

AV = Average Factor in -dB

In the radiated emission table which follows, the reading shown on the data table may reflect the preamplifier gain. An example of the calculations, where the reading does not reflect the preamplifier gain, follows:

$$FS = RA + AF + CF - AG + PD + AV$$

#### Example

Assume a receiver reading of 62.0 dB $\mu$ V is obtained. The antenna factor of 7.4 dB and cable factor of 1.6 dB is added. The amplifier gain of 29.0 dB is subtracted. The pulse desensitization factor of the spectrum analyzer is 0.0 dB, and the resultant average factor is -10.0 dB. The net field strength for comparison to the appropriate emission limit is 32.0 dB $\mu$ V/m. This value in dB $\mu$ V/m is converted to its corresponding level in  $\mu$ V/m.

$$RA = 62.0 \text{ dB}\mu\text{V}$$

$$AF = 7.4 \text{ dB}$$

$$CF = 1.6 \text{ dB}$$

$$AG = 29.0 \text{ dB}$$

$$PD = 0.0 \text{ dB}$$

$$AV = -10 \text{ dB}$$

$$FS = 62.0 + 7.4 + 1.6 - 29.0 + 0.0 + (-10.0) = 32.0 \text{ dB}\mu\text{V/m}$$

$$\text{Level in } \mu\text{V/m} = \text{Common Antilogarithm } [(32.0 \text{ dB}\mu\text{V/m})/20] = 39.8 \mu\text{V/m}$$

## TEST REPORT

### 4.6 Transmitter Radiated Emissions in Restricted Bands and Spurious Emissions

Data is included of the worst-case configuration (the configuration which resulted in the highest emission levels). A sample calculation, configuration photographs and data tables of the emissions are included.

The data on the following pages list the significant emission frequencies, the limit and the margin of compliance.

#### 4.6.1 Radiated Emission Configuration Photograph

Worst Case Restricted Band Radiated Emission  
at

107.265 MHz

The worst case radiated emission configuration photographs are saved with filename: config photos.pdf

#### 4.6.2 Radiated Emission Data

The data in tables 1-7 list the significant emission frequencies, the limit and the margin of compliance.

Judgement -

Passed by 9.0 dB margin

**TEST REPORT**

**RADIATED EMISSION DATA**

Mode: TX-Channel 00

Table 1  
BT4 1Mbit

Polarization	Frequency (MHz)	Reading (dBµV)	Pre-Amp Gain (dB)	Antenna Factor (dB)	Net at 3m (Average) (dBµV/m)	Average Limit at 3m (dBµV/m)	Margin (dB)
H	2390.000	41.4	33	29.4	37.8	54.0	-16.2
V	4804.000	28.7	33	34.9	30.6	54.0	-23.4
V	12010.000	22.7	33	40.5	30.2	54.0	-23.8

Polarization	Frequency (MHz)	Reading (dBµV)	Pre-Amp Gain (dB)	Antenna Factor (dB)	Net at 3m - Peak (dBµV/m)	Peak Limit at 3m (dBµV/m)	Margin (dB)
H	2390.000	64.8	33	29.4	61.2	74.0	-12.8
V	4804.000	36.9	33	34.9	38.8	74.0	-35.2
V	12010.000	30.7	33	40.5	38.2	74.0	-35.8

- NOTES:
1. Peak detector is used for the emission measurement.
  2. Average detector is used for the average data of emission measurement.
  3. All measurements were made at 3 meters.
  4. Negative value in the margin column shows emission below limit.
  5. Horn antenna is used for the emission over 1000MHz.
  6. Emission within the restricted band meets the requirement of FCC Part 15 Section 15.205.

**TEST REPORT**

Mode: TX-Channel 19

Table 2  
BT4 1Mbit

Polarization	Frequency (MHz)	Reading (dBμV)	Pre-Amp Gain (dB)	Antenna Factor (dB)	Net at 3m (Average) (dBμV/m)	Average Limit at 3m (dBμV/m)	Margin (dB)
V	4880.000	28.6	33	34.9	30.5	54.0	-23.5
V	7320.000	25.5	33	37.9	30.4	54.0	-23.6
V	12200.000	22.7	33	40.5	30.2	54.0	-23.8

Polarization	Frequency (MHz)	Reading (dBμV)	Pre-Amp Gain (dB)	Antenna Factor (dB)	Net at 3m - Peak (dBμV/m)	Peak Limit at 3m (dBμV/m)	Margin (dB)
V	4880.000	37.0	33	34.9	38.9	74.0	-35.1
V	7320.000	33.3	33	37.9	38.2	74.0	-35.8
V	12200.000	31.1	33	40.5	38.6	74.0	-35.4

- NOTES:
1. Peak detector is used for the emission measurement.
  2. Average detector is used for the average data of emission measurement
  3. All measurements were made at 3 meters.
  4. Negative value in the margin column shows emission below limit.
  5. Horn antenna is used for the emission over 1000MHz.
  6. Emission within the restricted band meets the requirement of FCC Part 15 Section 15.205.



**TEST REPORT**

Mode: TX-Channel 39

Table 3  
BT4 1Mbit

Polarization	Frequency (MHz)	Reading (dBμV)	Pre-Amp Gain (dB)	Antenna Factor (dB)	Net at 3m (Average) (dBμV/m)	Average Limit at 3m (dBμV/m)	Margin (dB)
H	2483.500	41.4	33	29.4	37.8	54.0	-16.2
V	4960.000	28.3	33	34.9	30.2	54.0	-23.8
V	7440.000	25.3	33	37.9	30.2	54.0	-23.8
V	12400.000	23.3	33	40.5	30.8	54.0	-23.2

Polarization	Frequency (MHz)	Reading (dBμV)	Pre-Amp Gain (dB)	Antenna Factor (dB)	Net at 3m - Peak (dBμV/m)	Peak Limit at 3m (dBμV/m)	Margin (dB)
H	2483.500	55.2	33	29.4	51.6	74.0	-22.4
V	4960.000	36.9	33	34.9	38.8	74.0	-35.2
V	7440.000	33.9	33	37.9	38.8	74.0	-35.2
V	12400.000	31.1	33	40.5	38.6	74.0	-35.4

- NOTES:
1. Peak detector is used for the emission measurement.
  2. Average detector is used for the average data of emission measurement
  3. All measurements were made at 3 meters.
  4. Negative value in the margin column shows emission below limit.
  5. Horn antenna is used for the emission over 1000MHz.
  6. Emission within the restricted band meets the requirement of FCC Part 15 Section 15.205.

**TEST REPORT**

Mode: TX-Channel 00

Table 4  
BT4 2Mbit

Polarization	Frequency (MHz)	Reading (dBμV)	Pre-Amp Gain (dB)	Antenna Factor (dB)	Net at 3m (Average) (dBμV/m)	Average Limit at 3m (dBμV/m)	Margin (dB)
H	2390.000	40.8	33	29.4	37.2	54.0	-16.8
V	4804.000	28.3	33	34.9	30.2	54.0	-23.8
V	12010.000	22.9	33	40.5	30.4	54.0	-23.6

Polarization	Frequency (MHz)	Reading (dBμV)	Pre-Amp Gain (dB)	Antenna Factor (dB)	Net at 3m - Peak (dBμV/m)	Peak Limit at 3m (dBμV/m)	Margin (dB)
H	2390.000	55.0	33	29.4	51.4	74.0	-22.6
V	4804.000	36.5	33	34.9	38.4	74.0	-35.6
V	12010.000	31.3	33	40.5	38.8	74.0	-35.2

- NOTES:
1. Peak detector is used for the emission measurement.
  2. Average detector is used for the average data of emission measurement
  3. All measurements were made at 3 meters.
  4. Negative value in the margin column shows emission below limit.
  5. Horn antenna is used for the emission over 1000MHz.
  6. Emission within the restricted band meets the requirement of FCC Part 15 Section 15.205.

**TEST REPORT**

Mode: TX-Channel 19

Table 5  
BT4 2Mbit

Polarization	Frequency (MHz)	Reading (dBμV)	Pre-Amp Gain (dB)	Antenna Factor (dB)	Net at 3m (Average) (dBμV/m)	Average Limit at 3m (dBμV/m)	Margin (dB)
V	4880.000	28.3	33	34.9	30.2	54.0	-23.8
V	7320.000	25.3	33	37.9	30.2	54.0	-23.8
V	12200.000	23.3	33	40.5	30.8	54.0	-23.2

Polarization	Frequency (MHz)	Reading (dBμV)	Pre-Amp Gain (dB)	Antenna Factor (dB)	Net at 3m - Peak (dBμV/m)	Peak Limit at 3m (dBμV/m)	Margin (dB)
V	4880.000	36.9	33	34.9	38.8	74.0	-35.2
V	7320.000	33.9	33	37.9	38.8	74.0	-35.2
V	12200.000	30.9	33	40.5	38.4	74.0	-35.6

- NOTES:
1. Peak detector is used for the emission measurement.
  2. Average detector is used for the average data of emission measurement
  3. All measurements were made at 3 meters.
  4. Negative value in the margin column shows emission below limit.
  5. Horn antenna is used for the emission over 1000MHz.
  6. Emission within the restricted band meets the requirement of FCC Part 15 Section 15.205.

**TEST REPORT**

Mode: TX-Channel 39

Table 6  
BT4 2Mbit

Polarization	Frequency (MHz)	Reading (dBμV)	Pre-Amp Gain (dB)	Antenna Factor (dB)	Net at 3m (Average) (dBμV/m)	Average Limit at 3m (dBμV/m)	Margin (dB)
H	2483.500	43.0	33	29.4	39.4	54.0	-14.6
V	4960.000	28.3	33	34.9	30.2	54.0	-23.8
V	7440.000	25.3	33	37.9	30.2	54.0	-23.8
V	12400.000	23.3	33	40.5	30.8	54.0	-23.2

Polarization	Frequency (MHz)	Reading (dBμV)	Pre-Amp Gain (dB)	Antenna Factor (dB)	Net at 3m - Peak (dBμV/m)	Peak Limit at 3m (dBμV/m)	Margin (dB)
H	2483.500	55.4	33	29.4	51.8	74.0	-22.2
V	4960.000	36.5	33	34.9	38.4	74.0	-35.6
V	7440.000	33.7	33	37.9	38.6	74.0	-35.4
V	12400.000	31.0	33	40.5	38.5	74.0	-35.5

- NOTES:
1. Peak detector is used for the emission measurement.
  2. Average detector is used for the average data of emission measurement
  3. All measurements were made at 3 meters.
  4. Negative value in the margin column shows emission below limit.
  5. Horn antenna is used for the emission over 1000MHz.
  6. Emission within the restricted band meets the requirement of FCC Part 15 Section 15.205.

**TEST REPORT**

Mode: Normal Mode BLE Operating

Table 7

Polarization	Frequency (MHz)	Reading (dBµV)	Pre-amp (dB)	Antenna Factor (dB)	Net at 3m (dBµV/m)	Limit at 3m (dBµV/m)	Margin (dB)
V	62.904	28.5	16	10.0	22.5	40.0	-17.5
V	96.054	26.8	16	12.0	22.8	43.5	-20.7
V	103.002	35.6	16	13.0	32.6	43.5	-10.9
V	107.265	36.5	16	14.0	34.5	43.5	-9.0
V	131.154	24.4	16	14.0	22.4	43.5	-21.1
V	164.668	21.2	16	17.0	22.2	43.5	-21.3
H	784.024	5.2	16	31.0	20.2	46.0	-25.8

- NOTES:
1. Quasi-Peak detector is used for the emission measurement.
  2. All measurements were made at 3 meters.
  3. Negative value in the margin column shows emission below limit.
  4. Emission within the restricted band meets the requirement of FCC Part 15 Section 15.205.

**TEST REPORT**

4.6.3 Radiated Emission Test Setup

The figure below shows the test setup, which is utilized to make these measurements.

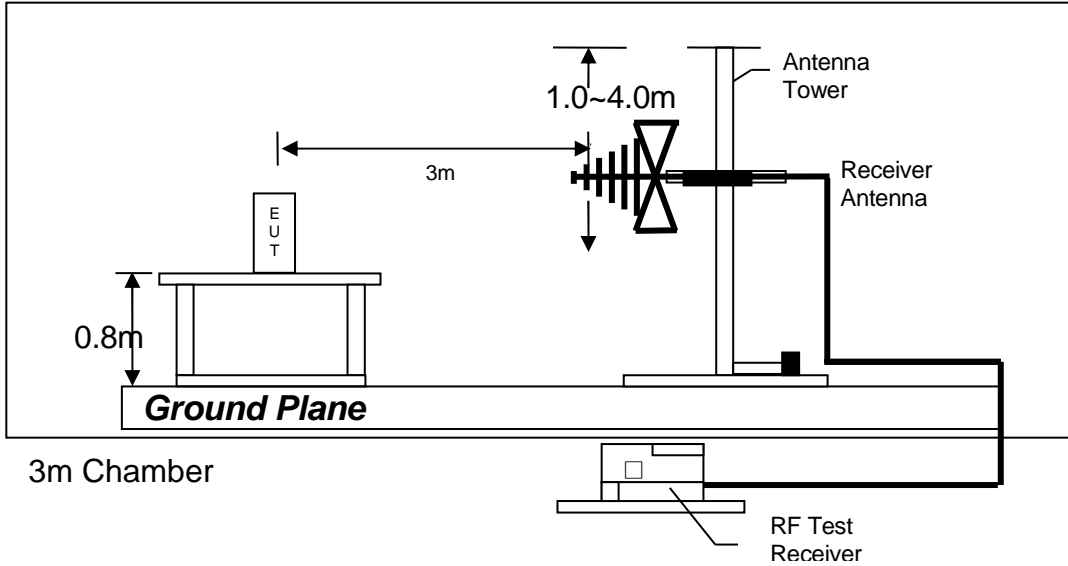

Test setup of radiated emissions up to 1GHz

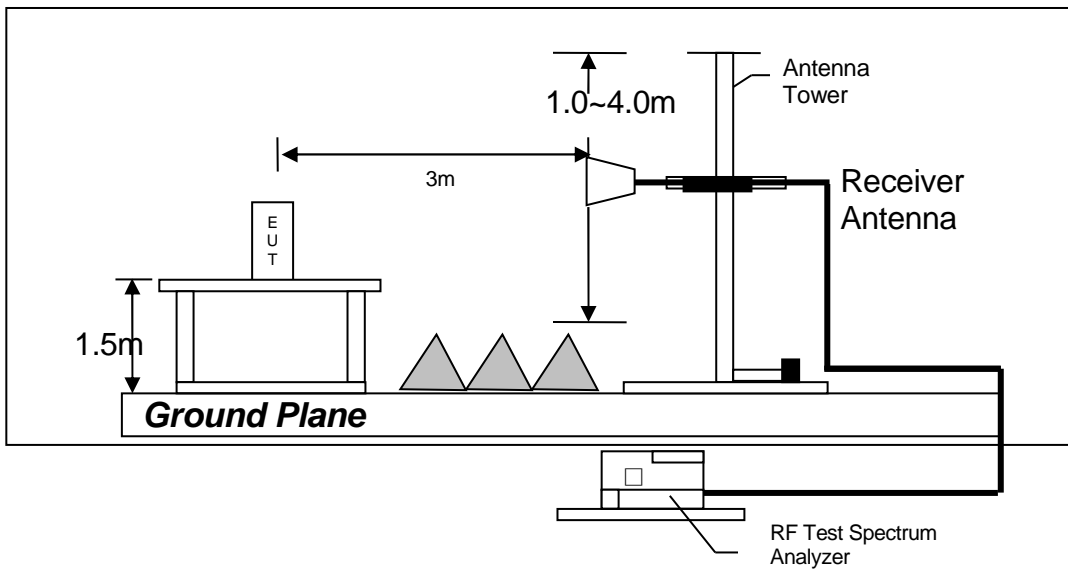

Test setup of radiated emissions above 1GHz

## TEST REPORT

### 4.6.4 Transmitter Duty Cycle Calculation

Not applicable – No average factor is required.

## TEST REPORT

### 4.7 AC Power Line Conducted Emission

- Not applicable – EUT is only powered by battery for operation.
- EUT connects to AC power line. Emission Data is listed in following pages.
- Base Unit connects to AC power line and has transmission. Handset connects to AC power line but has no transmission. Emission Data of Base Unit is listed in following pages.



## TEST REPORT

### 5.0 EQUIPMENT LIST

#### 1) Radiated Emissions Test

Equipment	EMI Test Receiver	Spectrum Analyzer	Biconical Antenna (20MHz to 200MHz)
Registration No.	EW-3156	EW-2466	EW-3061
Manufacturer	ROHDESCHWARZ	ROHDESCHWARZ	EMCO
Model No.	ESR26	FSP30	3142E
Calibration Date	January 25, 2021	November 18, 2019	February 02, 2021
Calibration Due Date	January 25, 2022	August 18, 2022	August 02, 2022

Equipment	Log Periodic Antenna	Double Ridged Guide Antenna	Active Loop H-field (9kHz to 30MHz)
Registration No.	EW-3243	EW-1133	EW-2313
Manufacturer	EMCO	EMCO	ELECTROMETRI
Model No.	3148B	3115	EM-6876
Calibration Date	June 30, 2021	June 03, 2021	December 17, 2019
Calibration Due Date	December 30, 2022	June 03, 2022	December 17, 2021

Equipment	RF Preamplifier (9kHz to 6000MHz)	2.4GHz Notch Filter	14m Double Shield RF Cable (20MHz to 6GHz)
Registration No.	EW-3006b	EW-3435	EW-2074
Manufacturer	SCHWARZBECK	MICROWAVE	RADIALL
Model No.	BBV9718	N0324413	N(m)-RG142-BNC(m) L=14M
Calibration Date	November 25, 2019	November 16, 2019	November 14, 2019
Calibration Due Date	June 25, 2022	June 16, 2022	August 14, 2022

Equipment	Pyramidal Horn Antenna
Registration No.	EW-0905
Manufacturer	EMCO
Model No.	3160-09
Calibration Date	July 20, 2021
Calibration Due Date	January 20, 2023

**TEST REPORT**

2) Conductive Measurement Test

<b>Equipment</b>	<b>5m RF Cable (40GHz)</b>	<b>RF Power Meter with Power Sensor (N1921A)</b>	<b>Spectrum Analyzer</b>
Registration No.	EW-2701	EW-2270	EW-2466
Manufacturer	RADIALL	N/A	ROHDESCHWARZ
Model No.	sma m-m 5m 40G	AGILENTTECH	FSP30
Calibration Date	November 24, 2020	September 03, 2020	November 18, 2019
Calibration Due Date	February 24, 2022	December 13, 2021	August 18, 2022

3) Bandedge Measurement

<b>Equipment</b>	<b>Spectrum Analyzer</b>	<b>5m RF Cable (40GHz)</b>
Registration No.	EW-2466	EW-2701
Manufacturer	ROHDESCHWARZ	RADIALL
Model No.	FSP30	Sma m-m 5m 40G
Calibration Date	November 18, 2019	November 24, 2020
Calibration Due Date	August 18, 2022	February 24, 2022

**END OF TEST REPORT**