

793~806MHz

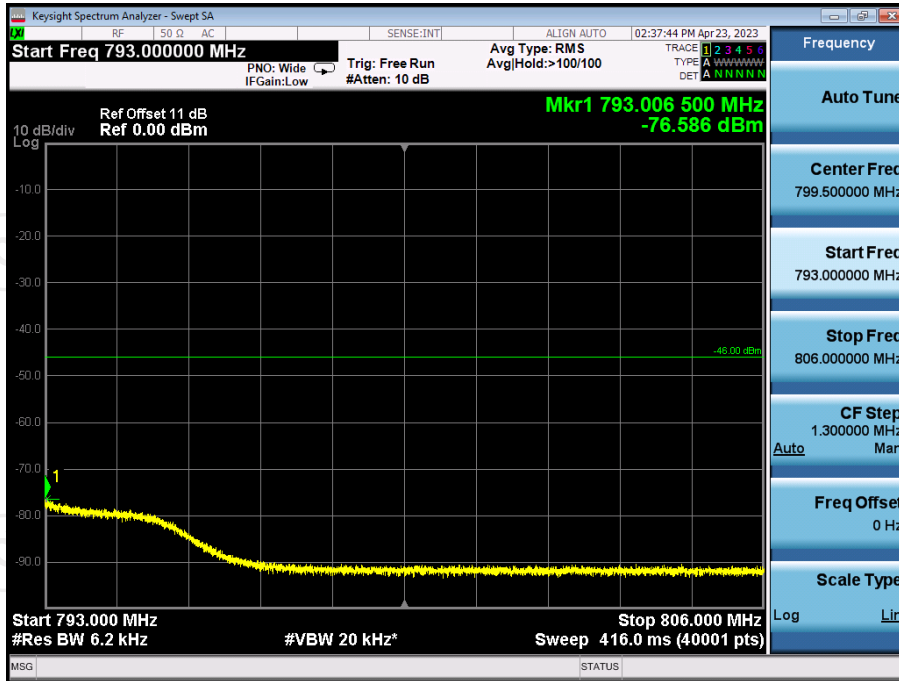

Upper700MHz Downlink

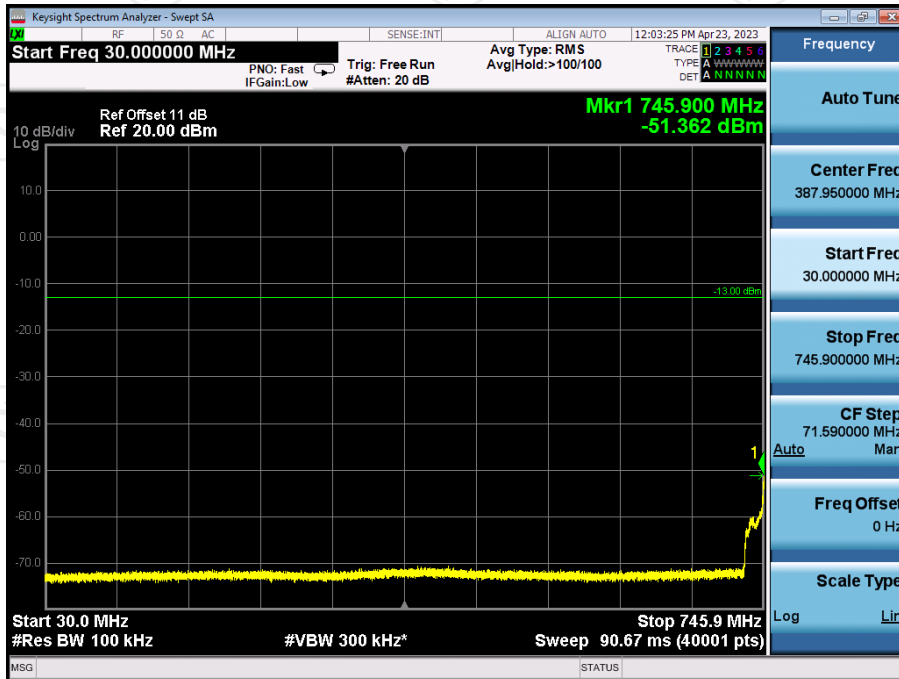

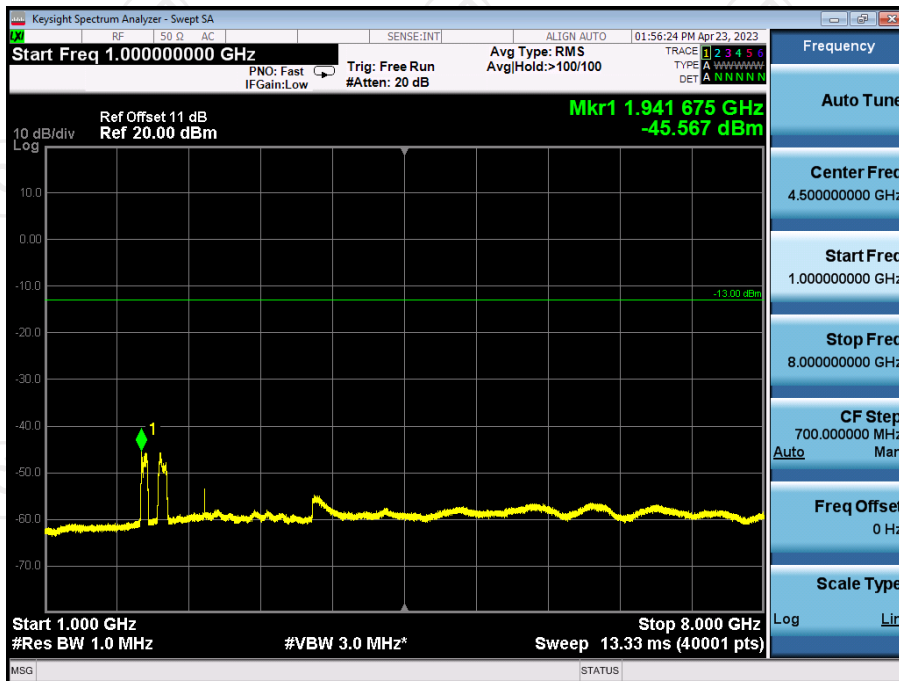
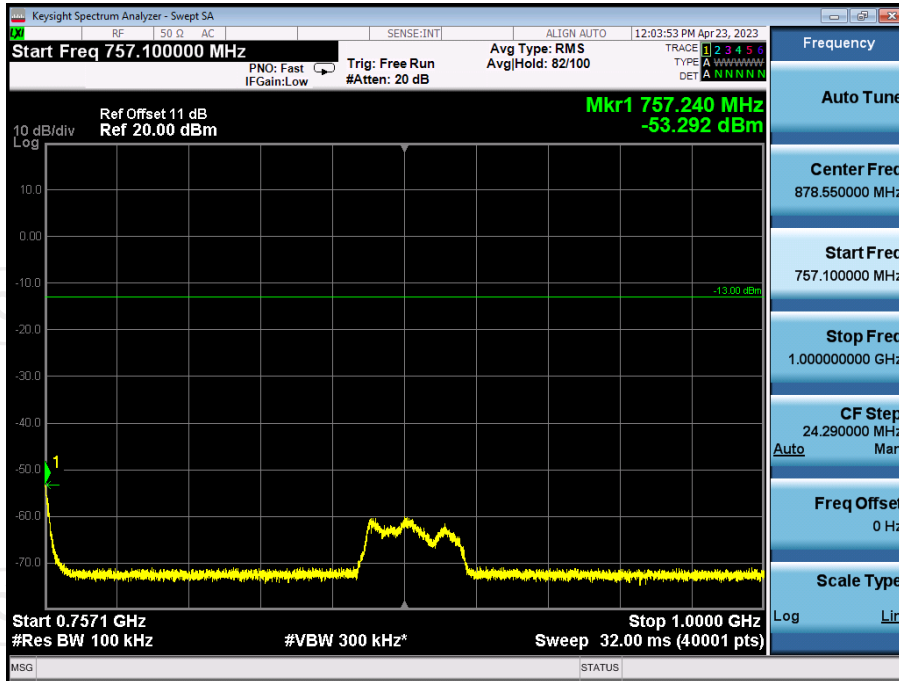

763~775MHz

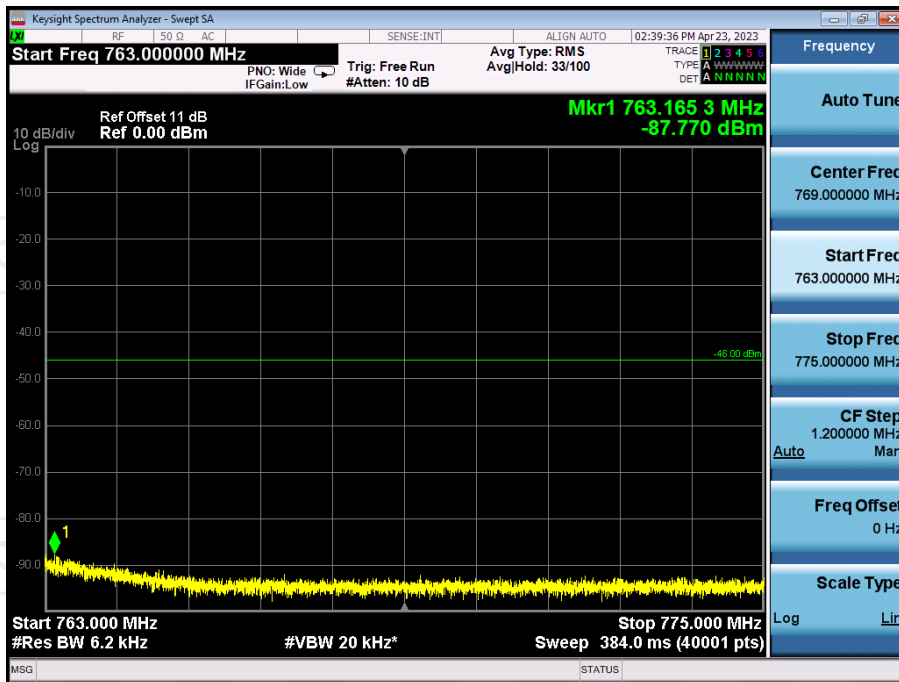

793~806MHz

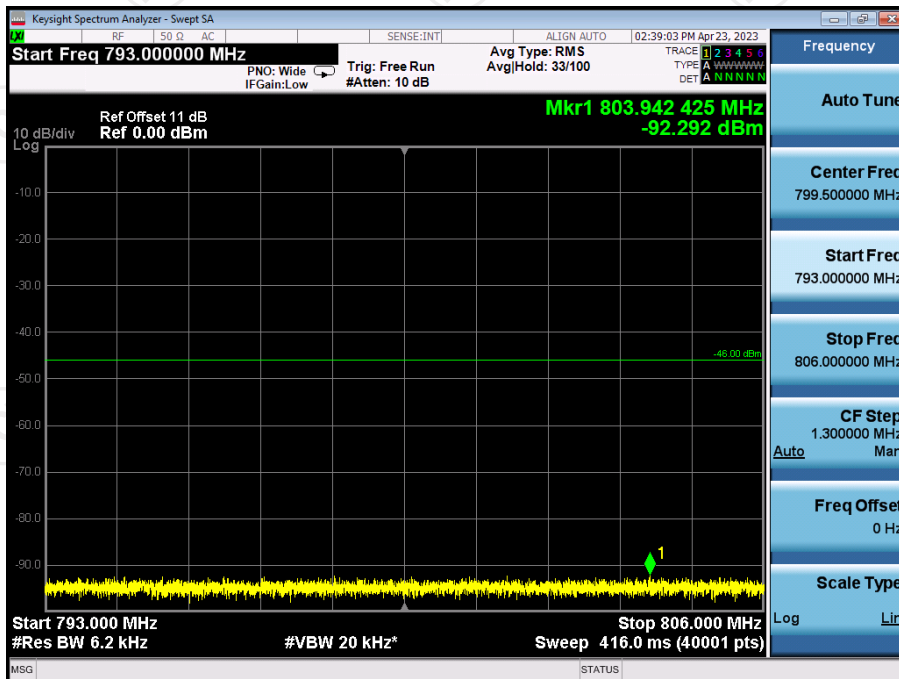

5.6. Noise Limits

5.6.1. Test Specification

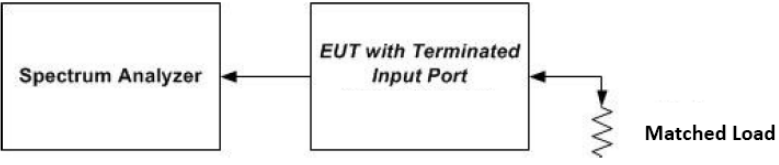
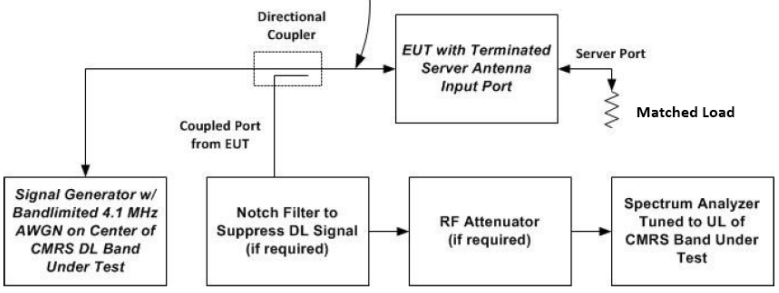
Test Requirement:	FCC Part20 Section 20.21(e)(8)(i)(A); 20.21(e)(8)(i)(H)
Test Method:	KDB935210 D03 Signal Booster Measurements v04r04
Limit:	not exceed -103 dBm/MHz —RSSI. not exceed $-102.5 \text{ dBm/MHz} + 20 \log (F)$, where Frequency is the uplink mid-band frequency of the supported spectrum bands in MHz.
Test Setup:	 <p style="text-align: center;">Figure 3 – Noise limit test setup (also used for 7.8)</p>  <p style="text-align: center;">Figure 4 – Test setup for uplink noise power measurement in the presence of a downlink signal</p>
Test Procedure:	<ol style="list-style-type: none"> a) Connect the EUT to the test equipment as shown in Figure 3. Begin with the uplink output (donor) port connected to the spectrum analyzer. When measuring downlink noise, connect the downlink output (server) port to the spectrum analyzer. b) Set the spectrum analyzer RBW to 1 MHz with the VBW $\geq 3 \cdot$ RBW. c) Select the power averaging (rms) detector and trace average over at least 100 traces. d) Set the center frequency of the spectrum analyzer to the center of the CMRS band under test with the span $\geq 2 \cdot$ the CMRS band. e) Measure the maximum transmitter noise power level. f) Save the spectrum analyzer Test Plots as necessary for inclusion in the final test report. g) Repeat 7.7b) to 7.7f) for all operational uplink and downlink bands. h) Connect the EUT to the test equipment as shown in Figure 4 for uplink noise power measurement in the presence a downlink signal. Affirm the coupled path of the RF coupler is connected to the spectrum analyzer. i) Configure the signal generator for AWGN operation with a 99% OBW of 4.1 MHz. j) Set the spectrum analyzer RBW for 1 MHz, VBW $\geq 3 \cdot$ RBW, with a power averaging (rms) detector with at least 100 trace averages. k) Set the center frequency of the spectrum analyzer to the center of

	<p>the CMRS band under test, with the span ≥ 2 the CMRS band. This shall include all spectrum blocks in the particular CMRS band under test (see Appendix A).</p> <p>l) For uplink noise measurements, set the spectrum analyzer center frequency for the uplink band under test, and tune the signal generator to the center of the paired downlink band.</p> <p>m) Measure the maximum transmitter noise power level while varying the downlink signal generator output level from -90 dBm to -20 dBm, as measured at the input port (i.e., downlink signal level at the booster donor port node of Figure 4), in 1 dB steps inside the RSSI-dependent region, and in 10 dB steps outside the RSSI-dependent region. Report the six values closest to the limit, with at least two points within the RSSI-dependent region of the limit. See Appendix D for noise limits graphs.</p> <p>n) Repeat 7.7.1h) through 7.7.1m) for all operational uplink bands.</p> <p>Variable uplink noise timing Variable uplink noise timing is to be measured as follows, using the test setup shown in Figure 4.</p> <p>a) Set the spectrum analyzer to the uplink frequency to be measured.</p> <p>b) Set the span to 0 Hz, with a sweep time of 10 seconds.</p> <p>c) Set the power level of signal generator to the lowest level of the RSSI-dependent noise [see 7.7.1m)].</p> <p>d) Select MAX HOLD and increase the power level of signal generator by 10 dB for mobile boosters, and 20 dB for fixed boosters.</p> <p>e) Confirm that the uplink noise decreases to the specified level within 1 second for mobile devices, and within 3 seconds for fixed devices.¹²</p> <p>f) Repeat 7.7.2a) to 7.7.2e) for all operational uplink bands.</p> <p>g) Include Test Plots and summary table in test report.</p>
Test Result:	PASS

5.6.2. Test Instruments

Equipment	Manufacturer	Model	Serial Number	Calibration Date	Calibration Due
Signal Generator	Agilent	N5182A	MY47070282	Jul. 04, 2022	Jul. 03, 2023
Spectrum Analyzer	Agilent	N9020A	MY49100619	Jul. 05, 2022	Jul. 04, 2023
RF Combiner	SUNVNDN	SUD-CS 0800	16230009	/	/
Attenuator	50FP-006-H3	JFW	907763	/	/

5.6.3. Test Data

Max Noise Power			
Frequency Band (MHz)	Measured dBm/MHz	Limit dBm/MHz	Result (dB)
PCS Uplink	-42.19	-37.02	PASS
AWS-1 Uplink	-43.55	-37.73	PASS
Cellular Uplink	-50.82	-44.05	PASS
Lower700MHz Uplink	-47.18	-45.51	PASS
Upper700MHz Uplink	-50.17	-44.64	PASS
PCS Downlink	-45.10	-37.02	PASS
AWS-1 Downlink	-46.67	-37.73	PASS
Cellular Downlink	-50.66	-44.05	PASS
Lower700MHz Downlink	-51.16	-45.51	PASS
Upper700MHz Downlink	-51.72	-44.64	PASS

Note: Fixed booster maximum noise power shall not exceed $-102.5 \text{ dBm/MHz} + 20 \log (F)$, where Frequency is the uplink mid-band frequency of the supported spectrum bands in MHz.

Variable Uplink Noise				
Operation Bands	RSSI dBm	Measured dBm/MHz	Limit dBm/MHz	Results
PCS	-61	-45.07	-42.00	PASS
	-60	-45.75	-43.00	PASS
	-59	-46.83	-44.00	PASS
	-58	-47.17	-45.00	PASS
	-57	-48.09	-46.00	PASS
	-56	-48.51	-47.00	PASS
AWS-1	-55	-46.25	-48.00	PASS
	-54	-46.50	-49.00	PASS
	-53	-47.18	-50.00	PASS
	-52	-47.52	-51.00	PASS
	-51	-47.74	-52.00	PASS
	-49	-48.21	-54.00	PASS
Cellular	-59	-51.24	-44.05	PASS
	-58	-51.74	-45.00	PASS

	-57	-52.76	-46.00	PASS
	-56	-53.00	-47.00	PASS
	-54	-55.36	-49.00	PASS
	-52	-56.43	-51.00	PASS
Lower700MHz	-60	-48.56	-45.51	PASS
	-59	-49.03	-45.51	PASS
	-57	-50.93	-46.00	PASS
	-55	-52.86	-48.00	PASS
	-53	-54.78	-50.00	PASS
	-51	-56.52	-52.00	PASS
Upper700MHz	-60	-50.60	-44.64	PASS
	-58	-51.86	-45.00	PASS
	-57	-52.64	-46.00	PASS
	-55	-54.53	-48.00	PASS
	-53	-56.36	-50.00	PASS
	-51	-57.92	-52.00	PASS

Note: According to the KDB 935210 D03 Signal Booster Measurements v04r04 APPENDIX D, when outside of RSSI Dependent limit (20.21.e.8.1.A.1), fixed booster maximum noise power shall not exceed $-102.5 \text{ dBm/MHz} + 20 \log (F)$. RSSI limit not exceed $-103 \text{ dBm/MHz-RSSI}$.

Variable Uplink Noise Timing

Operation Bands	Measured Sec	Limit Sec	Results
PCS	0.025	3	PASS
AWS-1	0.010	3	PASS
Cellular	0.025	3	PASS
Lower700MHz	0.015	3	PASS
Upper700MHz	0.020	3	PASS

Test Plots

PCS

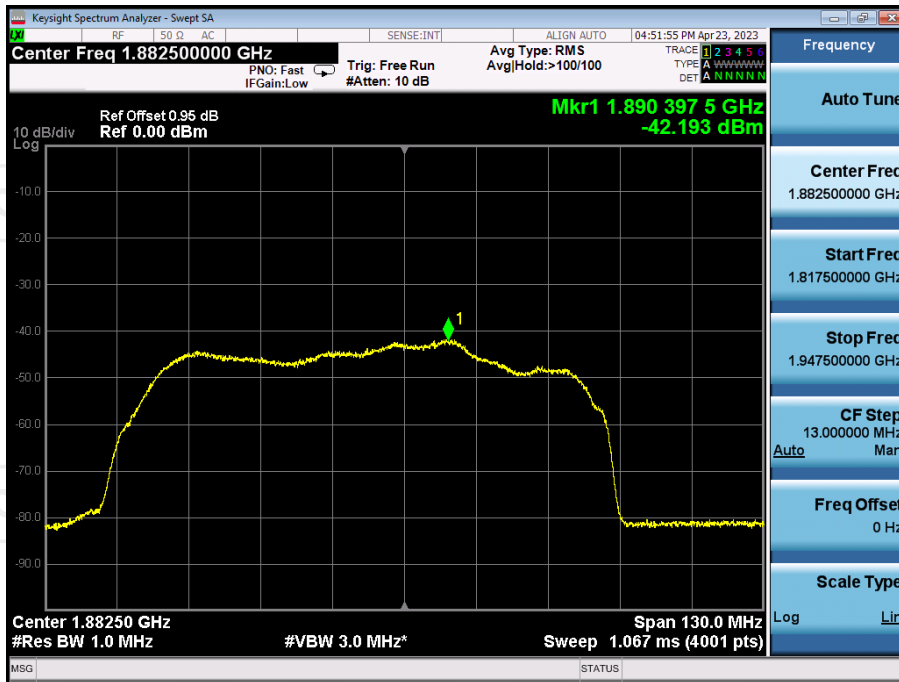

Uplink Noise

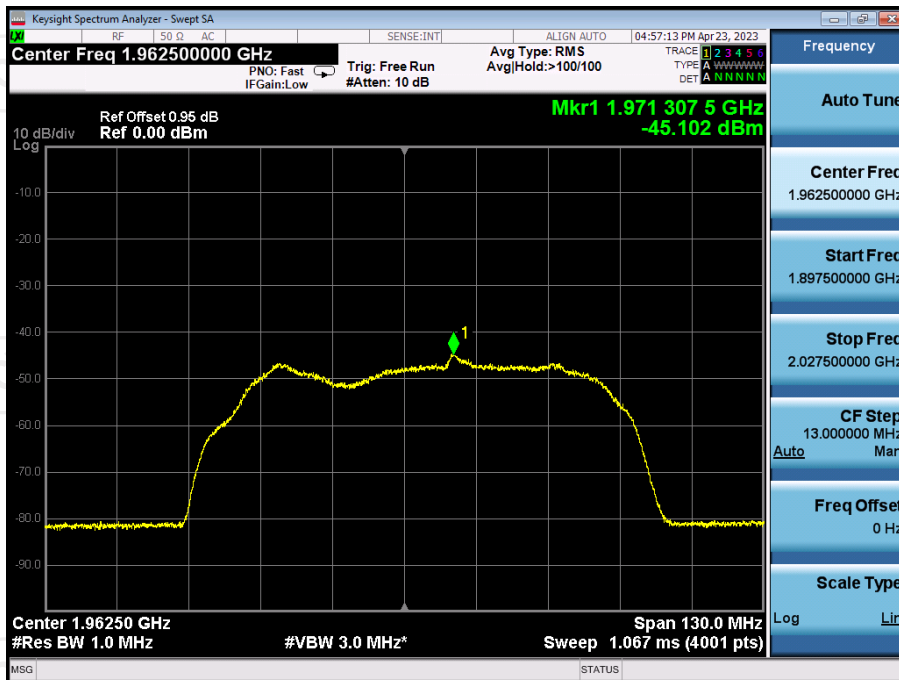

Downlink Noise

AWS-1

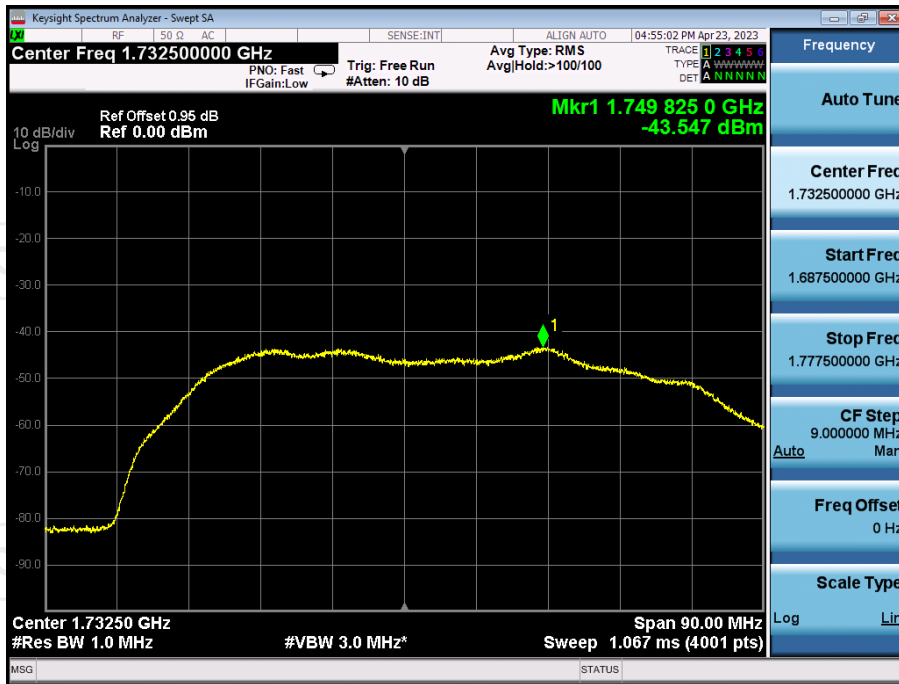

Uplink Noise



Downlink Noise

Cellular



Uplink Noise

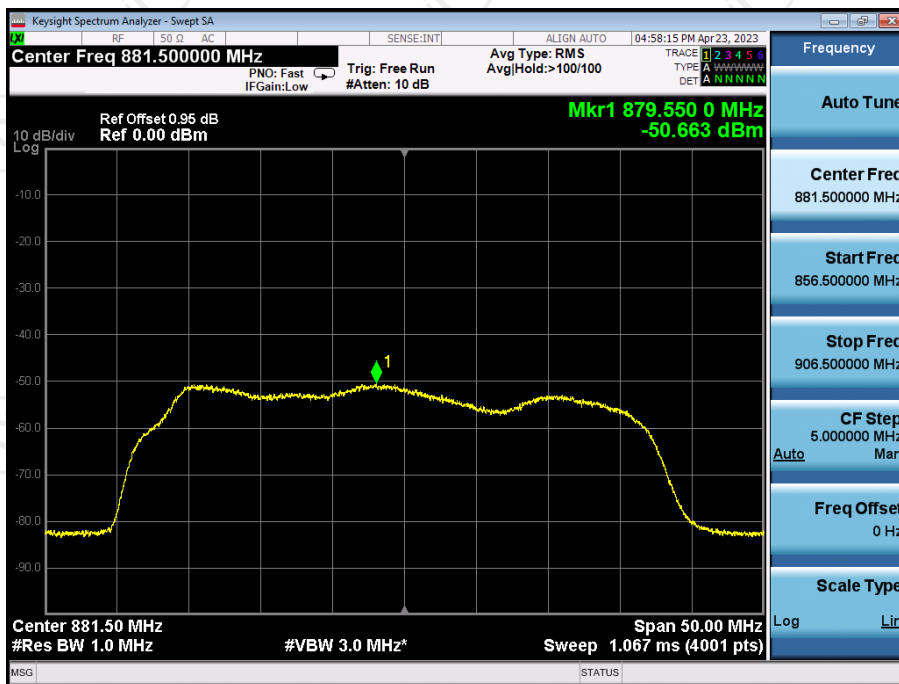

Downlink Noise

Lower700MHz

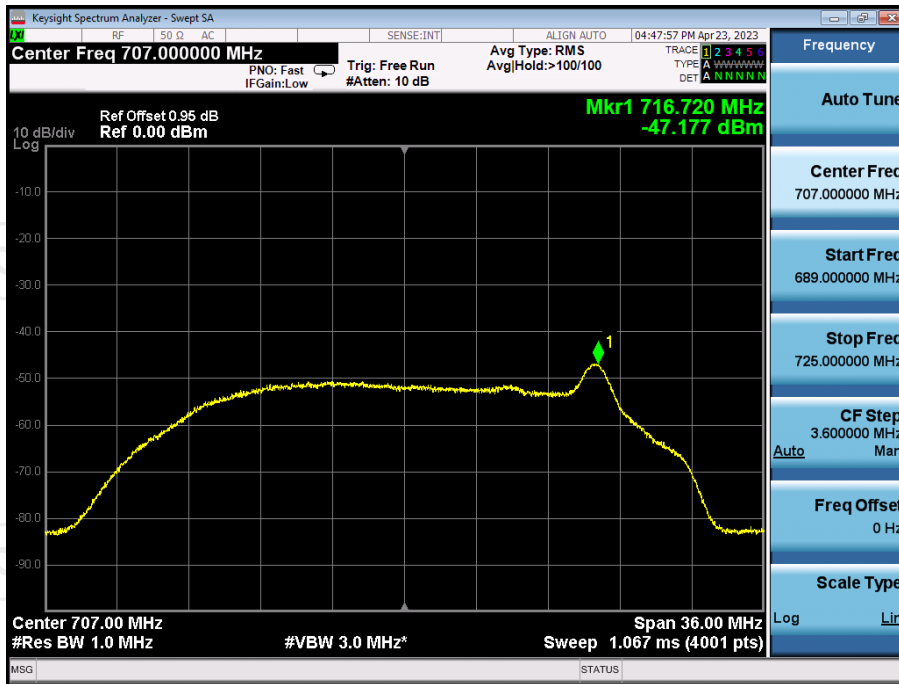

Uplink Noise

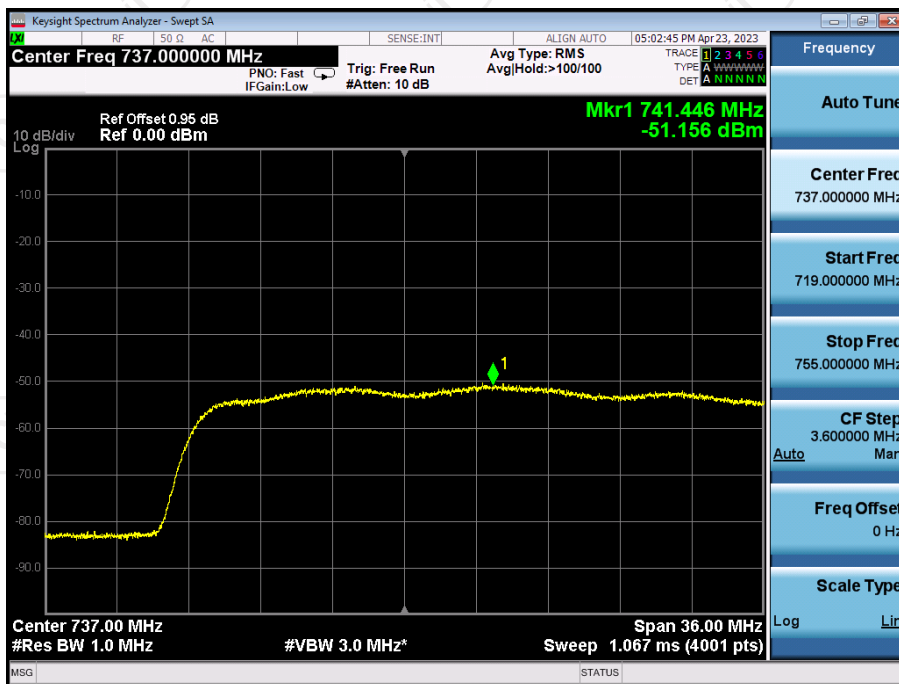

Downlink Noise

Upper700MHz

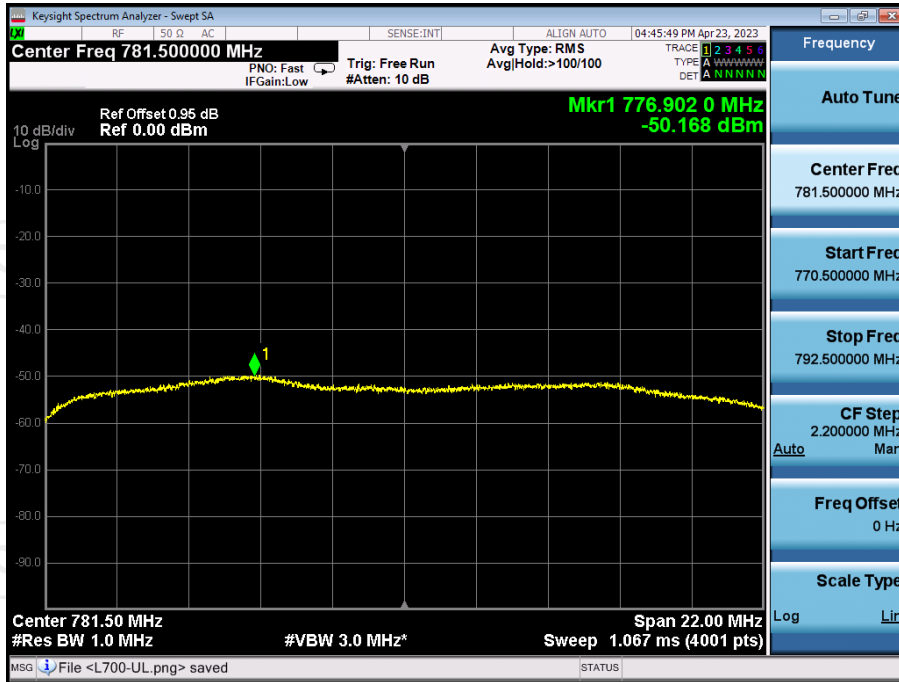

Uplink Noise



Downlink Noise

Cellular



Lower700MHz

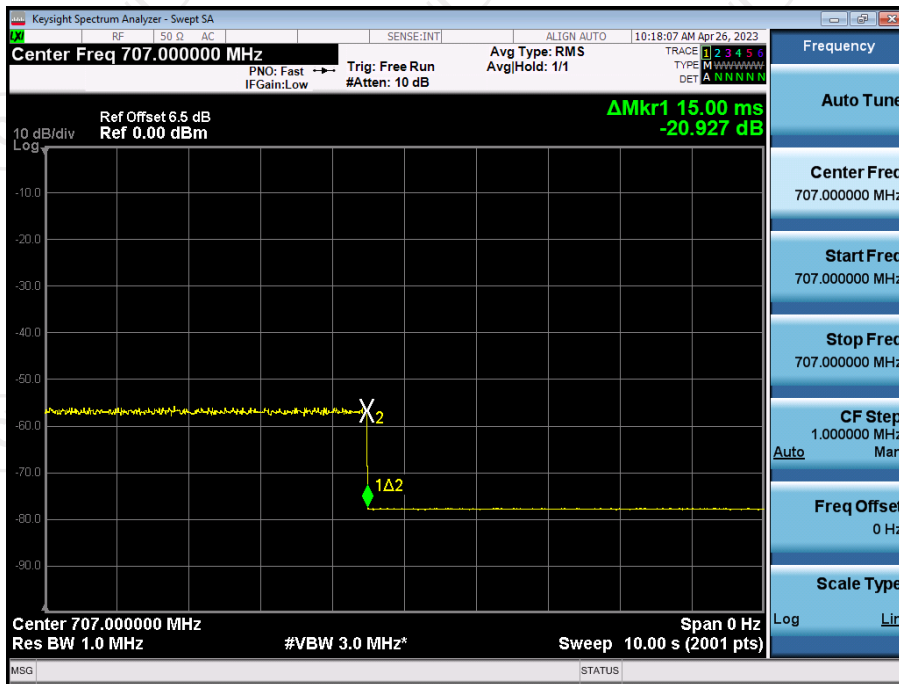

Upper700MHz



5.7. Uplink Inactivity

5.7.1. Test Specification

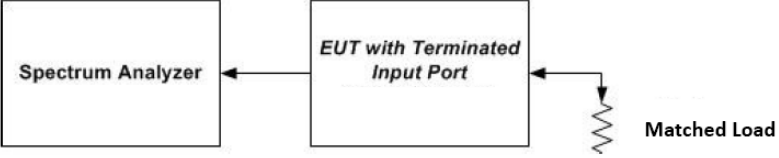
Test Requirement:	FCC Part20 Section 20.21(e)(8)(i)(I)
Test Method:	KDB935210 D03 Signal Booster Measurements v04r04
Limit:	20.21(e), When a consumer booster is not serving an active device connection after 5 minutes the uplink noise power shall not exceed -70 dBm/MHz.
Test Setup:	 <p style="text-align: center;">Figure 3 – Noise limit test setup (also used for 7.8)</p>
Test Procedure:	<ol style="list-style-type: none"> a) Connect the EUT to the test equipment as shown in Set-Up with the uplink output connected to the spectrum analyzer. b) Select the RMS power averaging detector. c) Set the spectrum analyzer RBW for 1 MHz with the VBW \geq 3X RBW. d) Set the center frequency of the spectrum analyzer to the center of the uplink operational band. e) Set the span for 0 Hz with a single sweep time for a minimum of 330 seconds. f) Start to capture a new trace using MAX HOLD. g) After approximately 15 seconds turn on the EUT power. h) Once the full spectrum analyzer trace is complete place a MARKER on the leading edge of the pulse and use the DELTA MARKER METHOD to measure the time until the uplink was squelched. i) Ensure the noise level for the squelched signal is below the uplink inactivity noise power limit, as specified by the rules. j) Capture the Test Plots for inclusion in the test report. k) Measure noise using procedures in a) to e). l) Repeat steps c) to k) for all operational uplink bands.
Test Result:	PASS

5.7.2. Test Instruments

Equipment	Manufacturer	Model	Serial Number	Calibration Date	Calibration Due
Spectrum Analyzer	Agilent	N9020A	MY49100619	Jul. 05, 2022	Jul. 04, 2023

5.7.3. Test Data

Uplink Inactivity			
Operation Bands	Measured (s)	Limit (s)	Result
PCS	267.6	300.0	PASS
AWS-1	268.3	300.0	PASS
Cellular	267.9	300.0	PASS
Lower700MHz	267.1	300.0	PASS
Upper700MHz	267.5	300.0	PASS

Test Plots

PCS

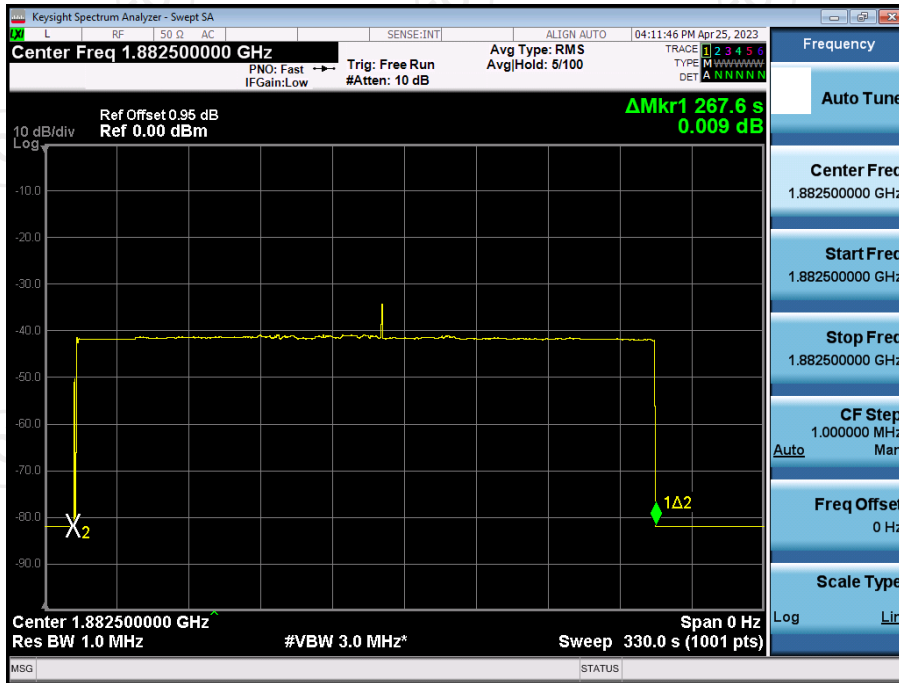

AWS-1



Cellular



Lower700MHz

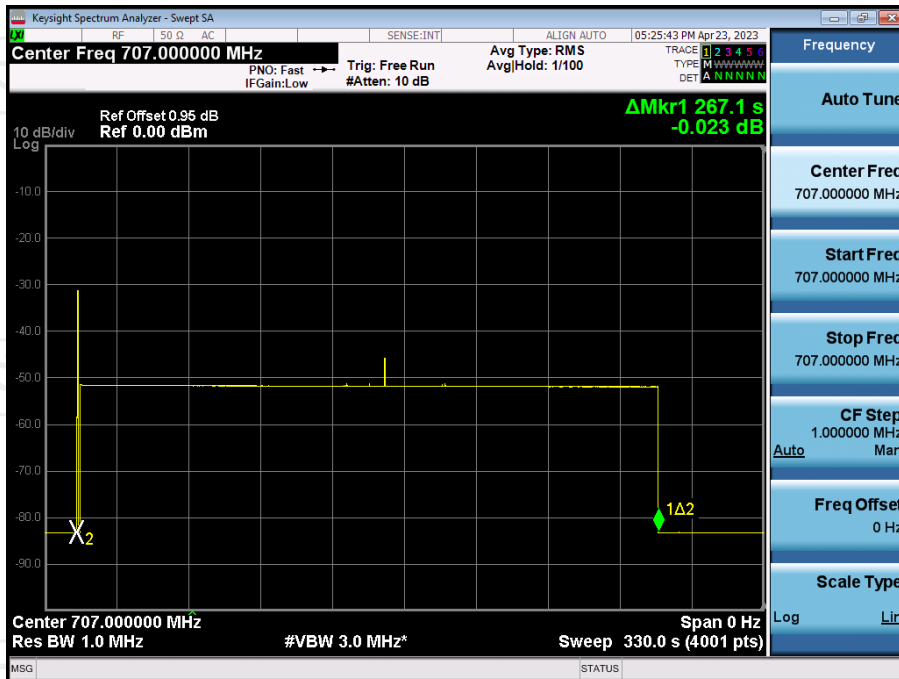

Upper700MHz



5.8. Variable Booster Gain

5.8.1. Test Specification

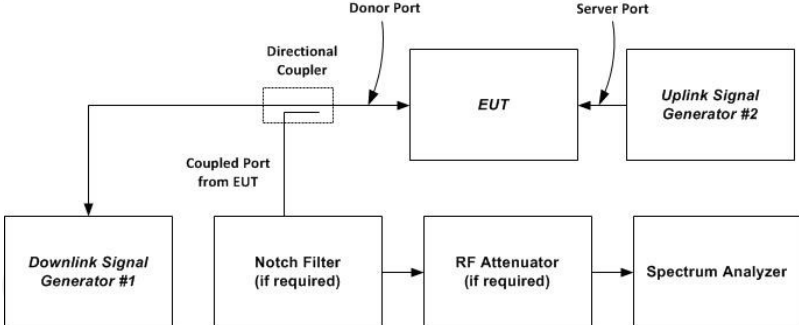
Test Requirement:	FCC Part20 Section 120.21(e)(8)(i)(C)(1) FCC Part20 Section 120.21(e)(8)(i)(H)
Test Method:	KDB935210 D03 Signal booster Measurements v04r04
Limit:	-34 dB - RSSI + MSCL
Test Setup:	 <p>Figure 5 – Variable gain instrumentation test setup</p>
Test Procedure:	<p>Variable gain:</p> <ol style="list-style-type: none"> Connect the EUT to the test equipment as shown in Figure 5 with the uplink output (donor) port connected to signal generator #1. Affirm that the coupled path of the RF coupler is connected to the spectrum analyzer. Configure downlink signal generator #1 for AWGN operation with a 99% OBW of 4.1 MHz, tuned to the center of the operational band. Set the power level and frequency of signal generator #2 to a value that is 5 dB below the AGC level determined from 7.2. The signal type is AWGN with a 99% OBW of 4.1 MHz. Set RBW = 100 kHz. Set VBW ≥ 300 kHz. Select the CHANNEL POWER measurement mode. Select the power averaging (rms) detector. Affirm that the number of measurement points per sweep ≥ (2 . span)/RBW. Sweep time = auto couple or as necessary (but no less than auto couple value). Trace average at least 10 traces in power averaging (i.e., rms) mode. Measure the maximum channel power and compute maximum gain when varying the signal generator #1 output to a level from .90 dBm to .20 dBm, as measured at the input port (i.e., downlink signal level at the booster donor port node of Figure 5), in 1 dB steps inside the RSSI-dependent region, and 10 dB steps outside the RSSI-dependent region. Report the six values closest to the limit, including at least two points from within the RSSI-dependent region of operation. See gain limit in charts in Appendix D for uplink gain requirements. Additionally, document that the EUT provides equivalent uplink and downlink gain, and when operating in shutoff mode that the uplink and downlink gain is within the transmit power off mode gain limits. Repeat 7.9.1b) to 7.9.1k) for all operational uplink bands. <p>Variable uplink gain timing: Variable uplink gain timing is to be measured as follows, using the test setup shown in Figure 5.</p>

	<p>a) Set the spectrum analyzer to the uplink frequency to be measured.</p> <p>b) Set the span to 0 Hz with a sweep time of 10 seconds.</p> <p>c) Set the power level of signal generator #1 to the lowest level of the RSSI-dependent gain [see 7.9.1k)].</p> <p>d) Select MAX HOLD and increase the power level of signal generator #1 by 10 dB for mobile boosters, and by 20 dB for fixed indoor boosters. Signal generator #2 remains same, as described in 7.9.1c).</p> <p>e) Confirm that the uplink gain decreases to the specified levels, within 1 second for mobile devices, and within 3 seconds for fixed devices.13</p> <p>f) Repeat 7.9.2a) to 7.9.2e) for all operational uplink bands.</p>
Test Result:	PASS

5.8.2. Test Instruments

Equipment	Manufacturer	Model	Serial Number	Calibration Date	Calibration Due
Signal Generator	Agilent	E4421B	GB39340839	Jul. 05, 2022	Jul. 04, 2023
Signal Generator	Agilent	N5182A	MY47070282	Jul. 04, 2022	Jul. 03, 2023
Spectrum Analyzer	Agilent	N9020A	MY49100619	Jul. 05, 2022	Jul. 04, 2023
RF Combiner	SUNVNDN	SUD-CS 0800	16230009	/	/
Attenuator	50FP-006-H3	JFW	907763	/	/

5.8.3. Test Data

Mobile station coupling loss (MSCL): the minimum coupling loss (in dB) between the wireless device and the input (server) port of the consumer booster. MSCL must be calculated or measured for each band of operation and provided in compliance test reports. MSCL includes the path loss from the wireless device, and the booster’s server antenna gain and cable loss. The wireless device is assumed to be an isotropic (0 dBi) antenna reference. Minimum standoff distances from inside wireless devices to the booster’s server antenna must be reasonable and specified by the manufacturer in customer provided installation manuals.

MSCL Calculation							
Operation Bands	Frequency (MHz)	Distance (m)	Path loss (dB)	Indoor Antenna Gain(dBi)	Indoor Cable Loss(dB)	Polarity Loss(dB)	MSCL (dB)
PCS	1850	2	43.86	8	3.1	3.01	41.97
AWS-1	1710	2	43.18	8	3.2	3.01	41.39
Cellular	824	2	36.84	8	1.9	3.01	33.75
Lower700 MHz	698	2	35.40	8	1.8	3.01	32.21
Upper700 MHz	776	2	36.32	8	1.8	3.01	33.13

Note : Path loss = $20\log f + 20\log d - 27.5$

Polarity loss = $20\log (1/\sin (45\text{deg})) \text{ dB} = 3.01\text{dB}$

Variable booster gain							
Operation Band	RSSI (dBm)	Input Power (dBm)	Output Power (dBm)	Measured Gain (dB)	MSCL	Limit	Results
PCS	-62	-44.0	16.39	60.39	41.97	69.97	PASS
	-60	-44.0	14.38	58.38	41.97	67.97	PASS
	-59	-44.0	14.21	58.21	41.97	66.97	PASS
	-58	-44.0	13.01	57.01	41.97	65.97	PASS
	-56	-44.0	10.04	54.04	41.97	63.97	PASS
	-55	-44.0	8.86	52.86	41.97	62.97	PASS
AWS-1	-62	-43.5	12.71	56.21	41.39	69.39	PASS
	-61	-43.5	11.94	55.44	41.39	68.39	PASS
	-60	-43.5	11.04	54.54	41.39	67.39	PASS
	-58	-43.5	8.43	51.93	41.39	65.39	PASS
	-57	-43.5	7.31	50.81	41.39	64.39	PASS
	-55	-43.5	5.03	48.53	41.39	62.39	PASS
Cellular	-57	-37.5	12.66	50.16	33.75	56.75	PASS
	-56	-37.5	12.64	50.14	33.75	55.75	PASS
	-55	-37.5	10.44	47.94	33.75	54.75	PASS
	-54	-37.5	9.43	46.93	33.75	53.75	PASS
	-52	-37.5	7.53	45.03	33.75	51.75	PASS
	-51	-37.5	6.23	43.73	33.75	50.75	PASS
	-60	-32.4	17.94	50.34	32.21	58.21	PASS

Lower700M Hz	-58	-32.4	16.41	48.81	32.21	56.21	PASS
	-57	-32.4	16.08	48.48	32.21	55.21	PASS
	-55	-32.4	12.97	45.37	32.21	53.21	PASS
	-53	-32.4	11.12	43.52	32.21	51.21	PASS
	-51	-32.4	8.21	40.61	32.21	49.21	PASS
Upper700M Hz	-61	-37.5	12.68	50.18	33.13	60.13	PASS
	-60	-37.5	11.86	49.36	33.13	59.13	PASS
	-59	-37.5	10.65	48.15	33.13	58.13	PASS
	-58	-37.5	9.69	47.19	33.13	57.13	PASS
	-56	-37.5	7.24	44.74	33.13	55.13	PASS
	-55	-37.5	6.51	44.01	33.13	54.13	PASS

Variable Uplink Gain Timing

Operation Band	Measured Sec	Limit Sec	Result
PCS	0.010	3.0	PASS
AWS-1	0.015	3.0	PASS
Cellular	0.020	3.0	PASS
Lower700MHz	0.020	3.0	PASS
Upper700MHz	0.015	3.0	PASS

Variable Uplink Gain Timing Test Plots

PCS

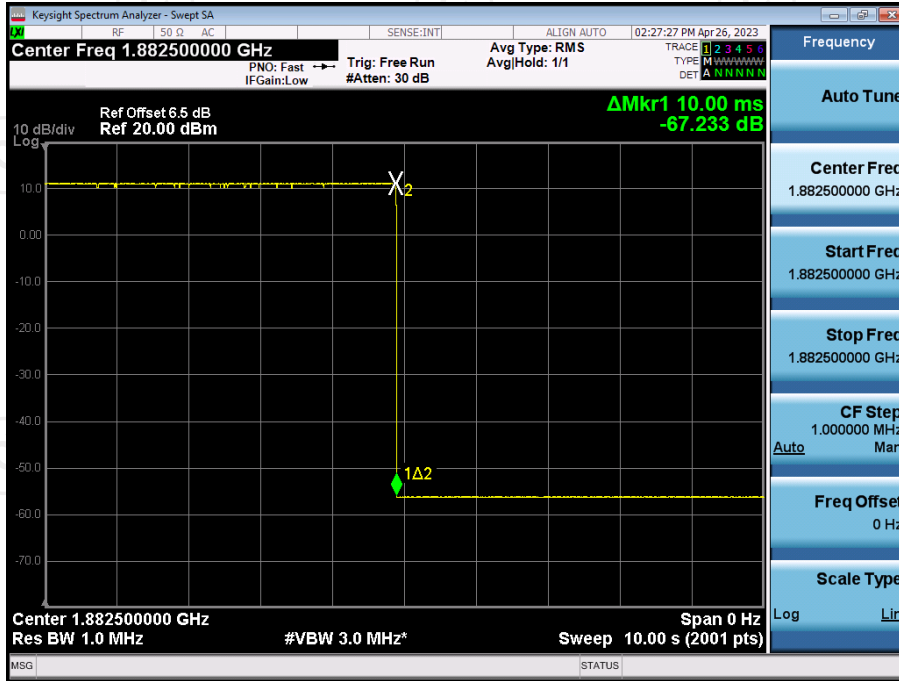

AWS-1

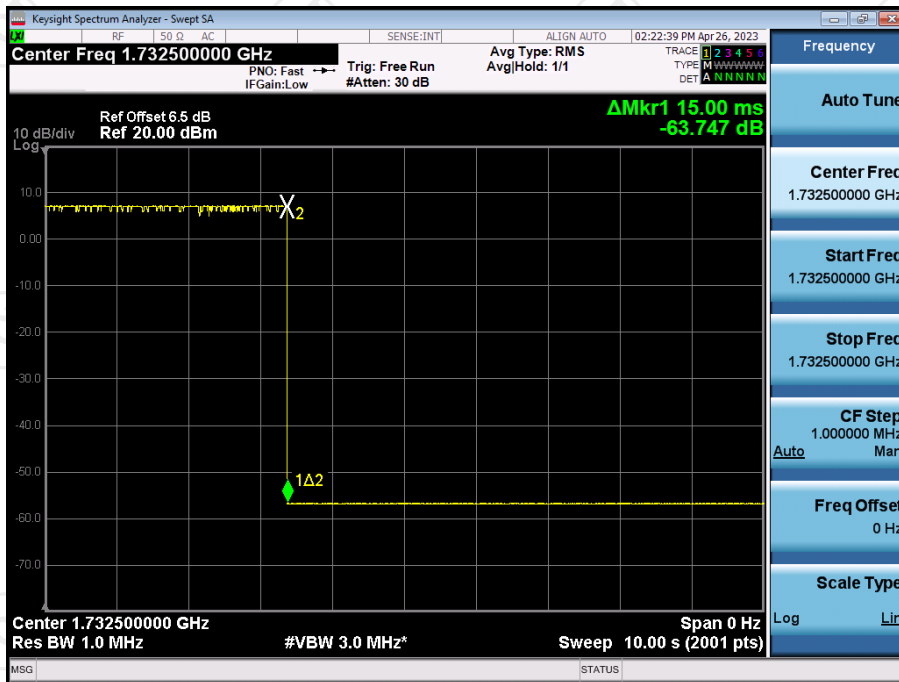

Cellular

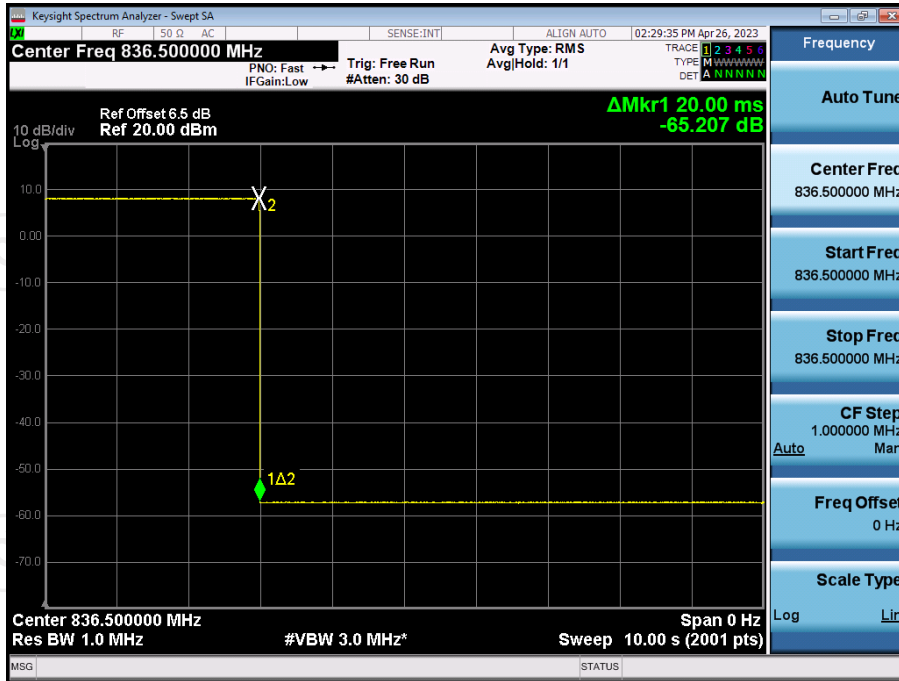

Lower700MHz

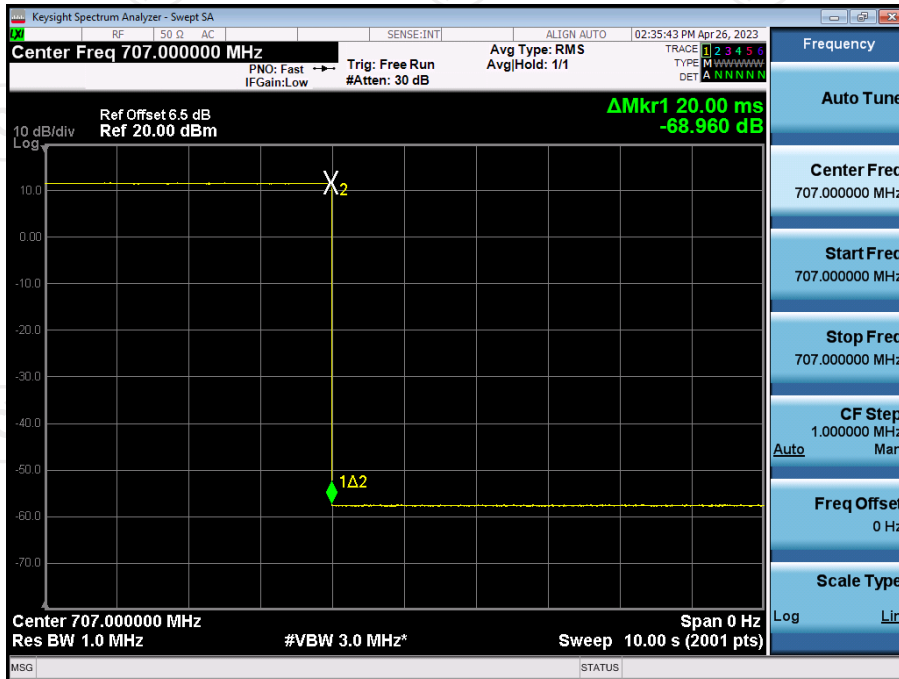

Upper700MHz

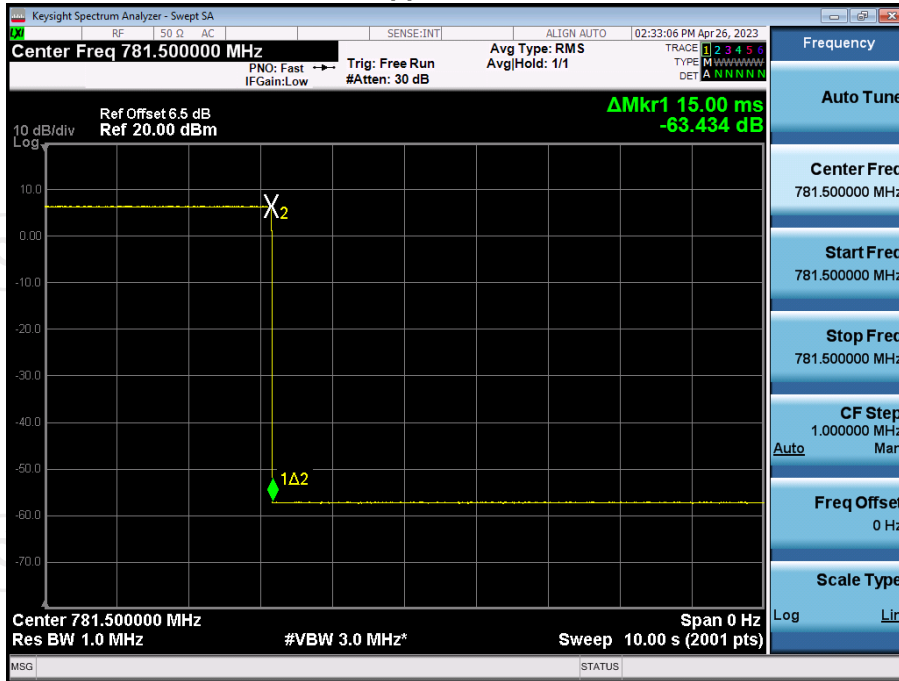

5.9. Occupied Bandwidth

5.9.1. Test Specification

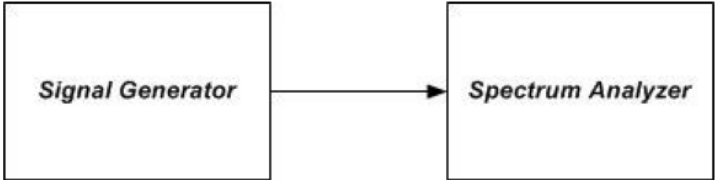
Test Requirement:	FCC Part2 Section 2.1049
Test Method:	KDB935210 D03 Signal booster Measurements v04r04
Limit:	N/A
Test setup:	 <p>Figure 6 – Test setup for measuring characteristics of test signals used for subsequent EUT occupied bandwidth testing</p>
Test Procedure:	<ol style="list-style-type: none"> a) Connect the test equipment as shown in Figure 6 to firstly measure the characteristics of the test signals produced by the signal generator. b) Set VBW \geq 3 RBW. c) Set the center frequency of the spectrum analyzer to the center of the operational band. The span will be adjusted for each modulation type and OBW as necessary for accurately viewing the signals. d) Set the signal generator for power level to match the values obtained from the tests of 7.2. e) Set the signal generator modulation type for GSM with a PRBS pattern and allow the trace on the signal generator to stabilize adjusting the span as necessary. f) Set the spectrum analyzer RBW for 1% to 5% of the EBW. g) Capture the spectrum analyzer trace for inclusion in the test report. h) Repeat 7.10c) to 7.10g) for CDMA and W-CDMA modulation, adjusting the span as necessary. AWGN or LTE may be used in place of W-CDMA, as an option. i) Repeat 7.10c) to 7.10h) for all uplink and downlink operational bands. j) Connect the test equipment as shown in Figure 1, with the uplink output (donor) port connected to the spectrum analyzer, and the server port connected to the signal generator. k) Repeat 7.10c) to 7.10i) with this EUT uplink path test setup. l) Connect the test equipment as shown in Figure 1, with the downlink output (server) port connected to the spectrum analyzer, and the donor port connected to the signal generator. m) Repeat 7.10c) to 7.10j) with this EUT downlink path test setup.
Test results:	PASS

5.9.2. Test Instruments

Equipment	Manufacturer	Model	Serial Number	Calibration Date	Calibration Due
Signal Generator	Agilent	N5182A	MY47070282	Jul. 04, 2022	Jul. 03, 2023
Spectrum Analyzer	Agilent	N9020A	MY49100619	Jul. 05, 2022	Jul. 04, 2023

5.9.3. Test Data

Operation Band		Signal Type	Input OBW [MHz]	Output OBW [MHz]	Results
Uplink	PCS	GSM	0.248	0.247	PASS
		CDMA	1.245	1.254	PASS
		LTE	4.491	4.510	PASS
	AWS-1	GSM	0.248	0.248	PASS
		CDMA	1.232	1.257	PASS
		LTE	4.499	4.550	PASS
	Cellular	GSM	0.250	0.248	PASS
		CDMA	1.241	1.243	PASS
		LTE	4.499	4.501	PASS
	Lower700M Hz	GSM	0.247	0.247	PASS
		CDMA	1.240	1.262	PASS
		LTE	4.503	4.515	PASS
	Upper700M Hz	GSM	0.248	0.247	PASS
		CDMA	1.247	1.242	PASS
		LTE	4.508	4.505	PASS
Downlink	PCS	GSM	0.256	0.248	PASS
		CDMA	1.271	1.242	PASS
		LTE	4.510	4.503	PASS
	AWS-1	GSM	0.254	0.248	PASS
		CDMA	1.262	1.241	PASS
		LTE	4.516	4.508	PASS
	Cellular	GSM	0.250	0.248	PASS
		CDMA	1.250	1.250	PASS
		LTE	4.869	4.510	PASS
	Lower700M Hz	GSM	0.247	0.247	PASS
		CDMA	1.257	1.250	PASS
		LTE	4.558	4.523	PASS
	Upper700M Hz	GSM	0.249	0.247	PASS
		CDMA	1.248	1.244	PASS
		LTE	4.650	4.500	PASS

Test Plots

PCS GSM UL Input

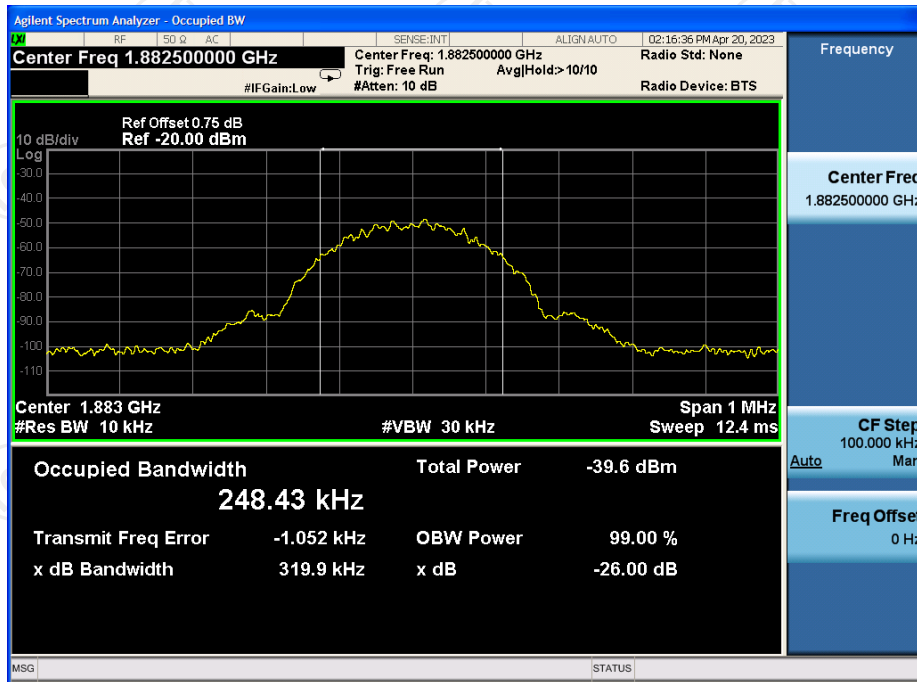

PCS GSM UL output

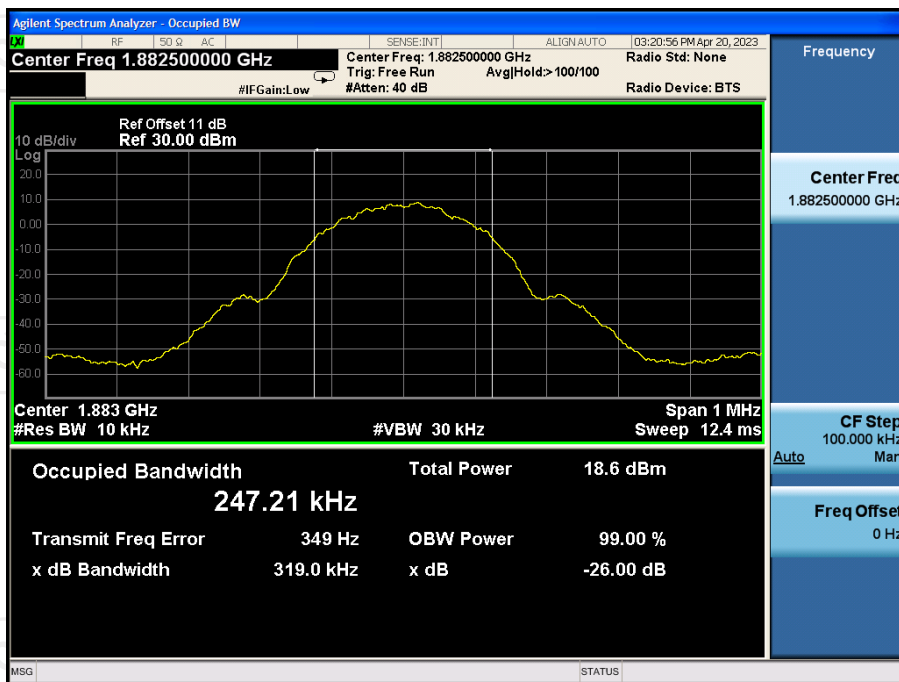

PCS GSM DL Input

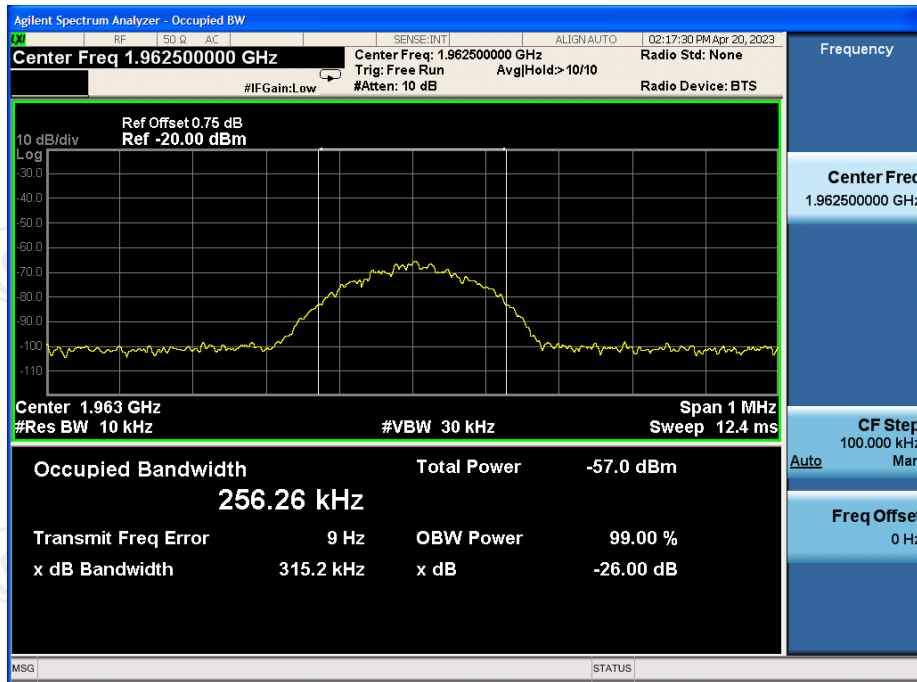

PCS GSM DL Output

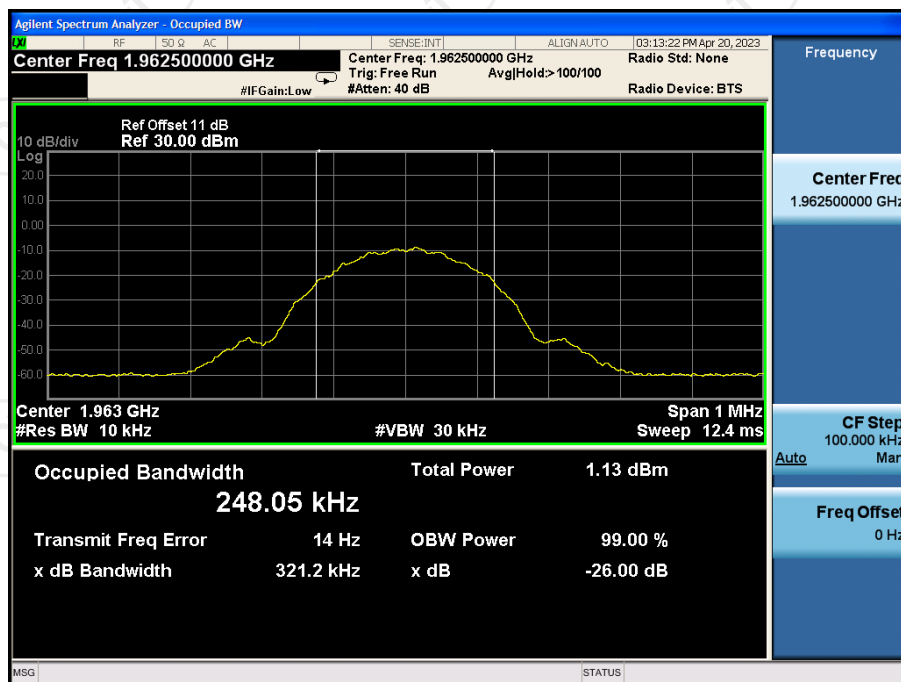

PCS CDMA DL Input

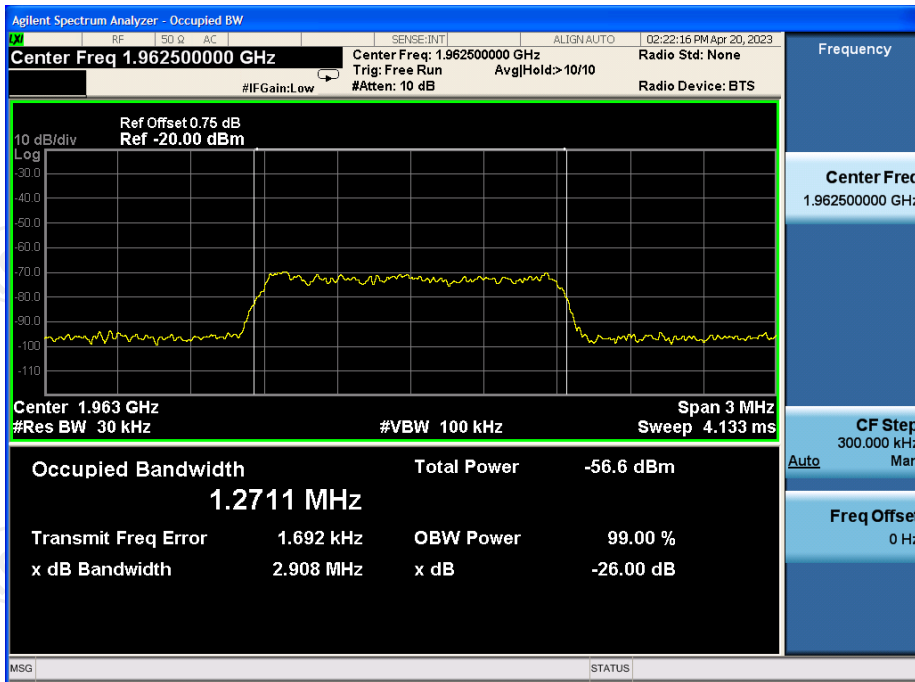

PCS CDMA DL Output

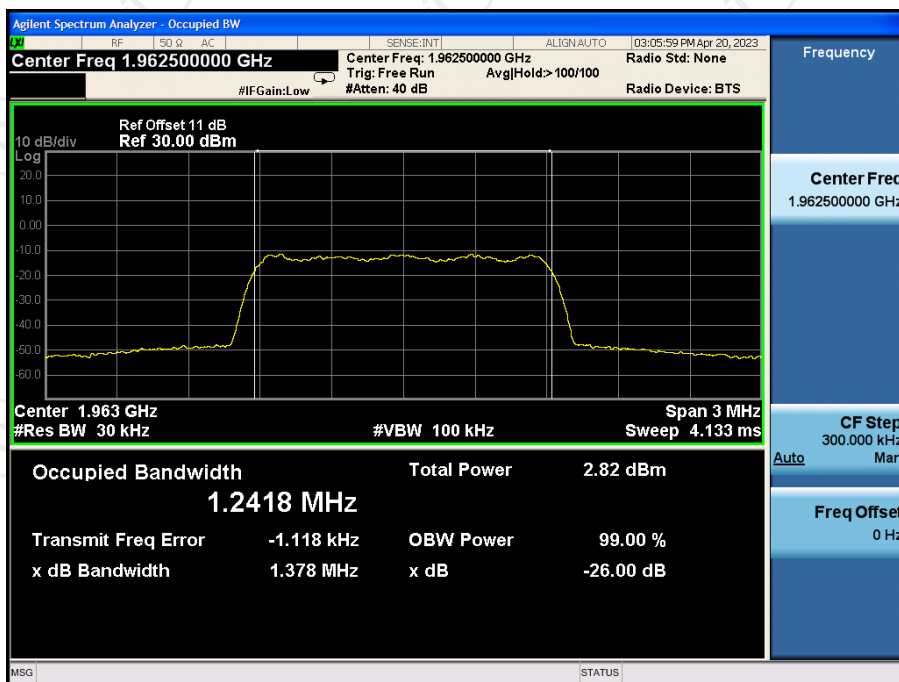

PCS LTE UL Input

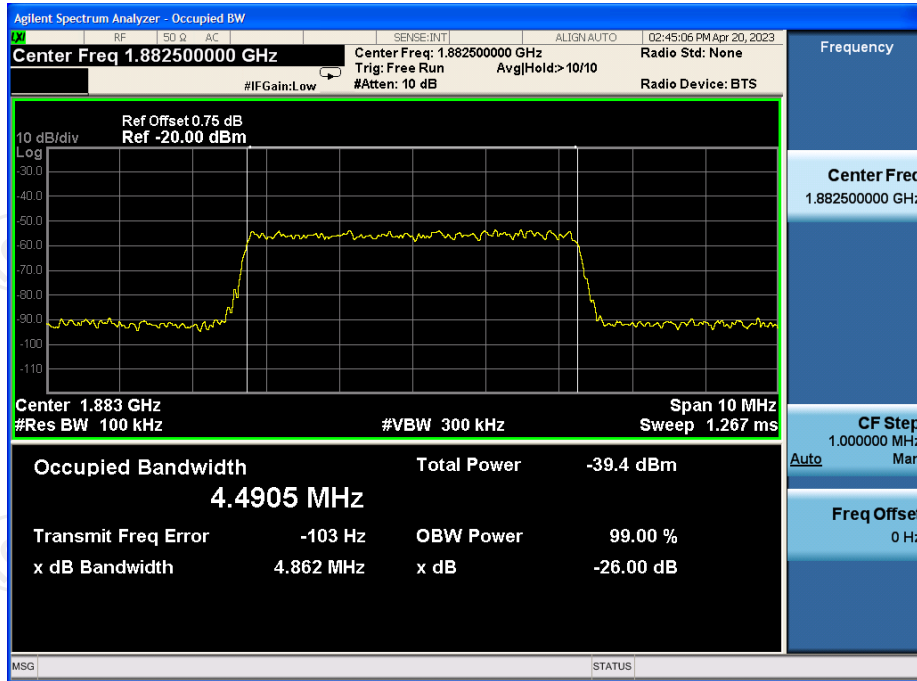

PCS LTE UL output

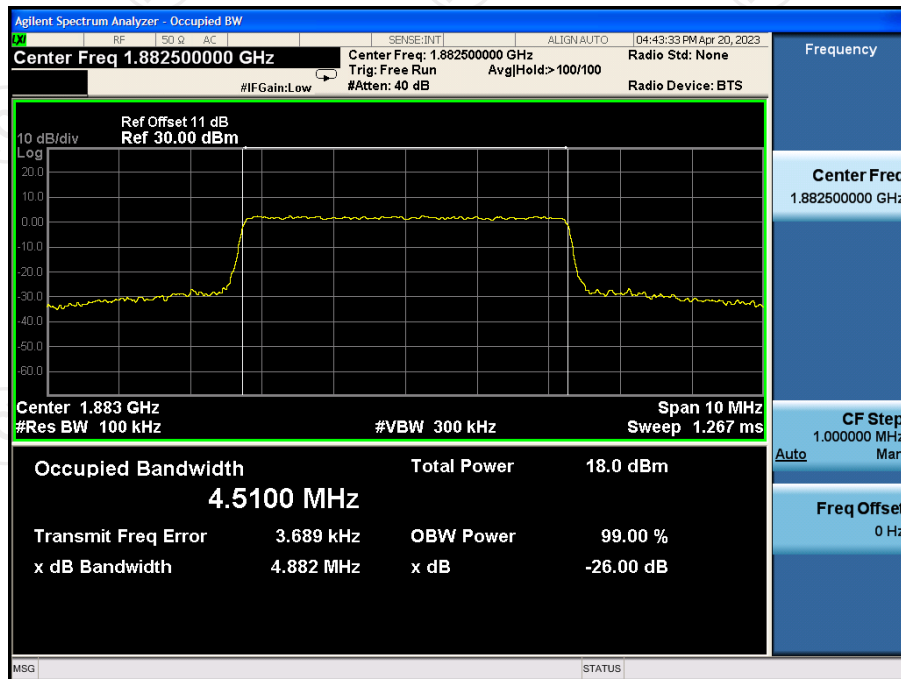

PCS LTE DL Input

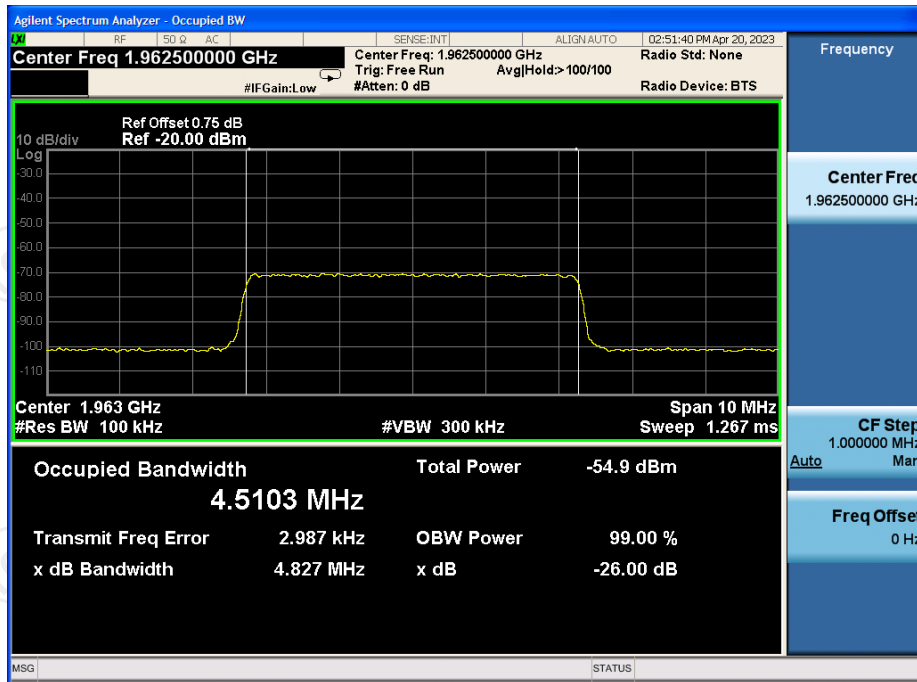

PCS LTE DL Output

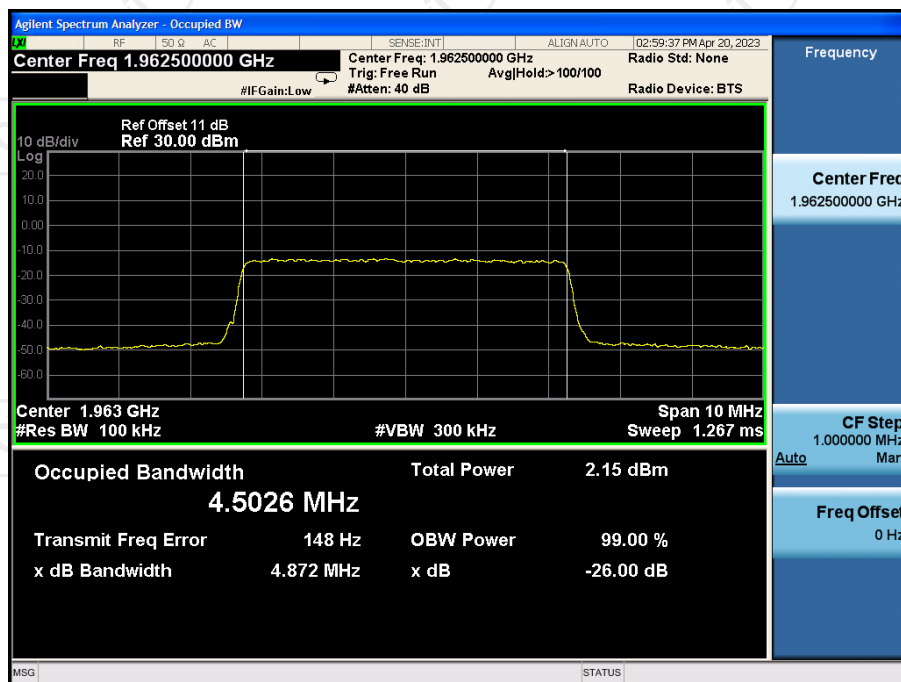

AWS-1 GSM UL Input

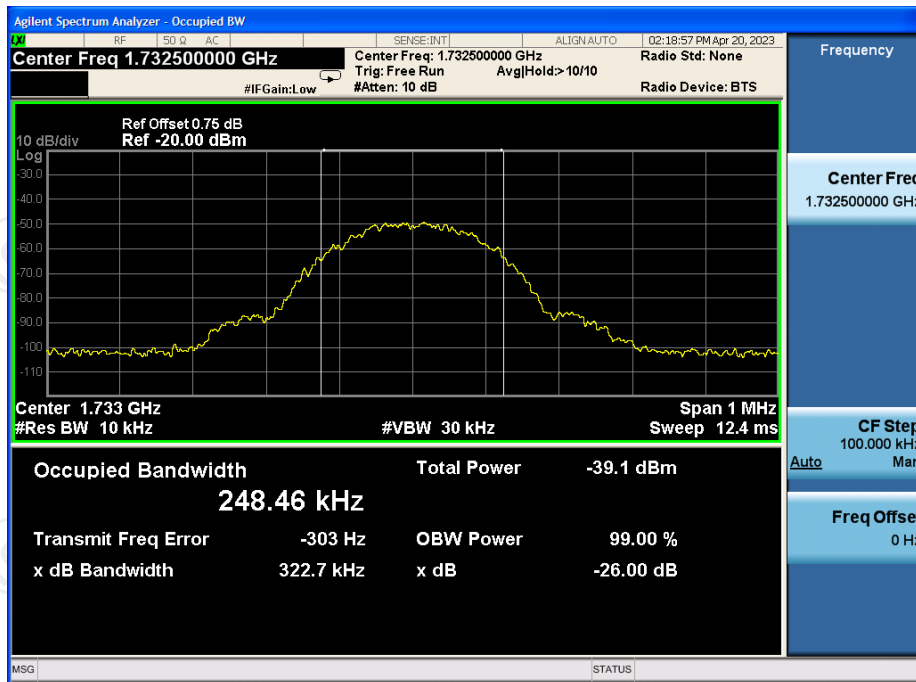

AWS-1 GSM UL output

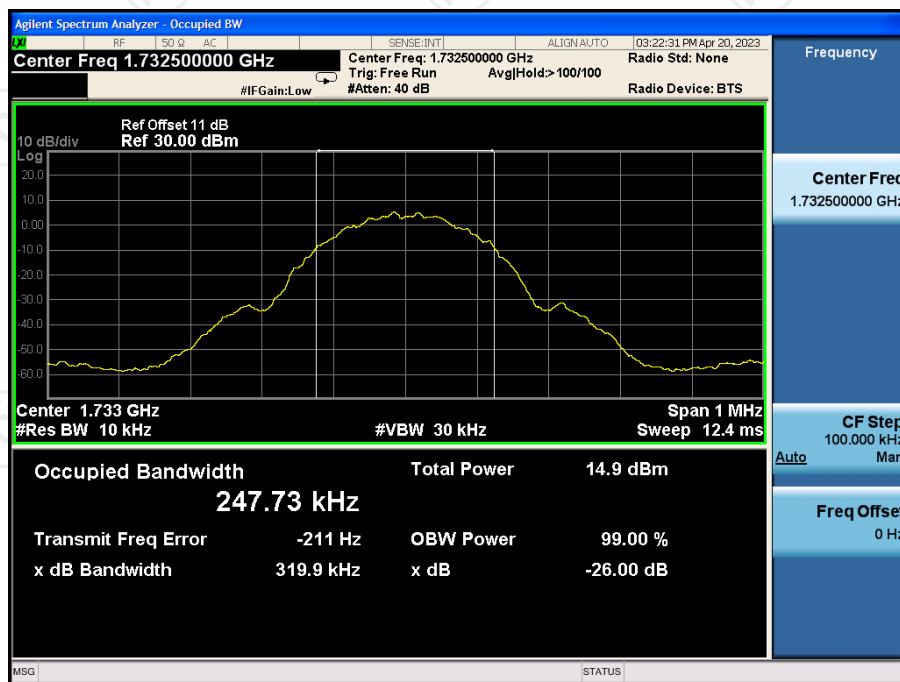

AWS-1 GSM DL Input

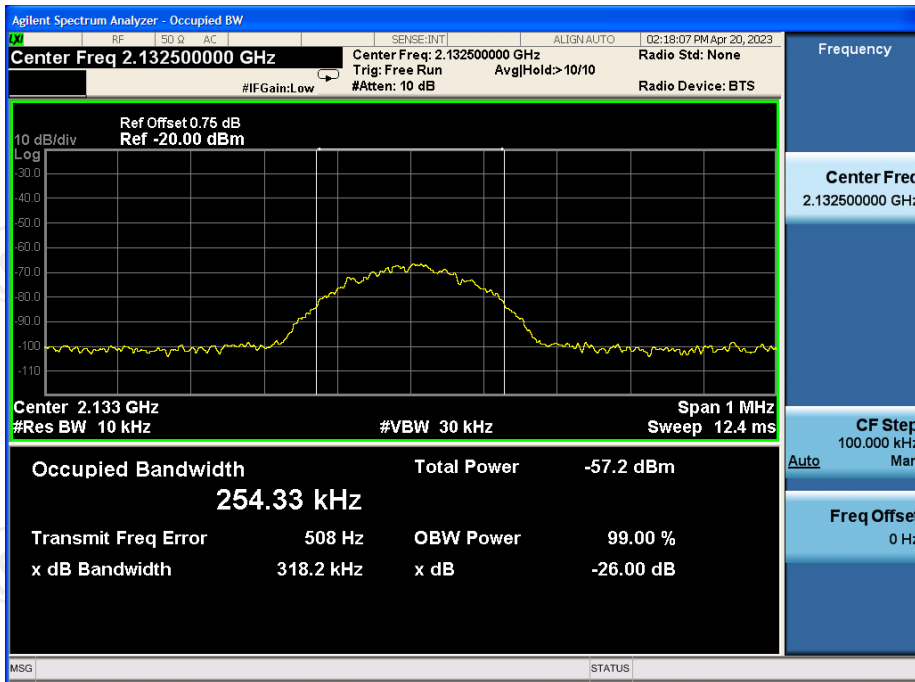

AWS-1 GSM DL Output

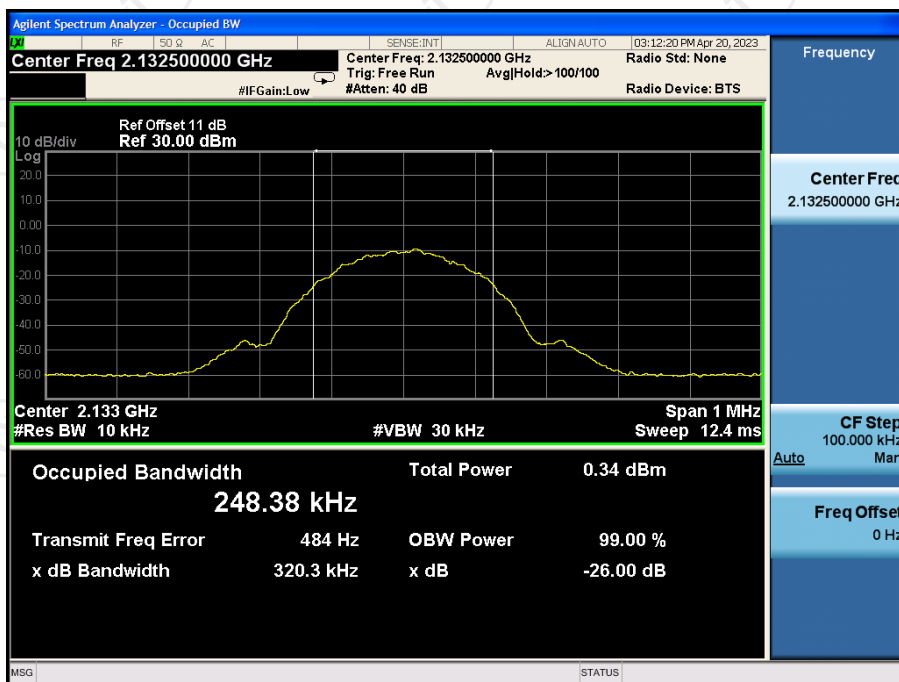

AWS-1 CDMA UL Input

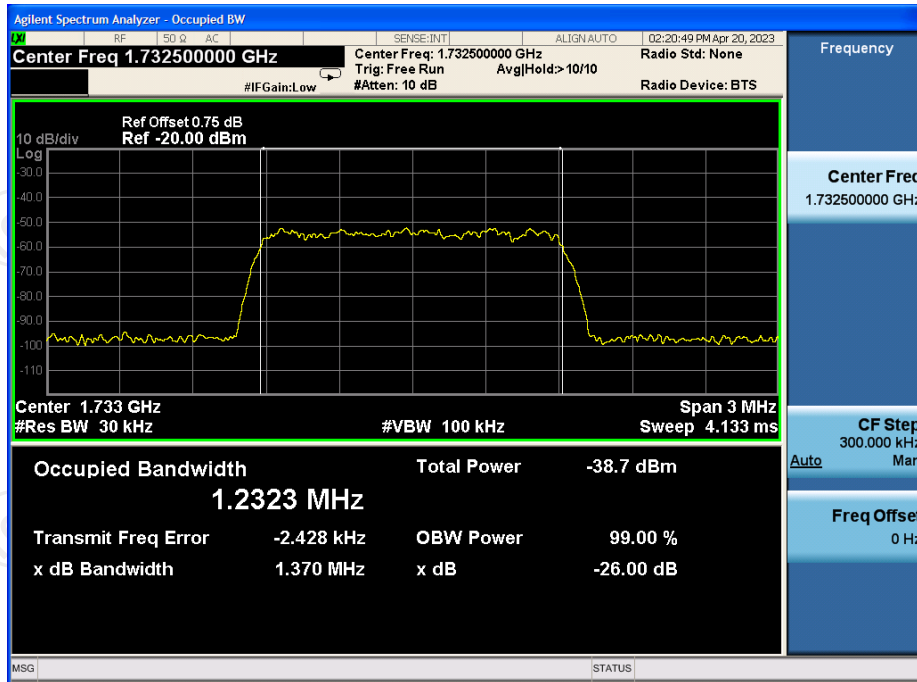

AWS-1 CDMA UL output

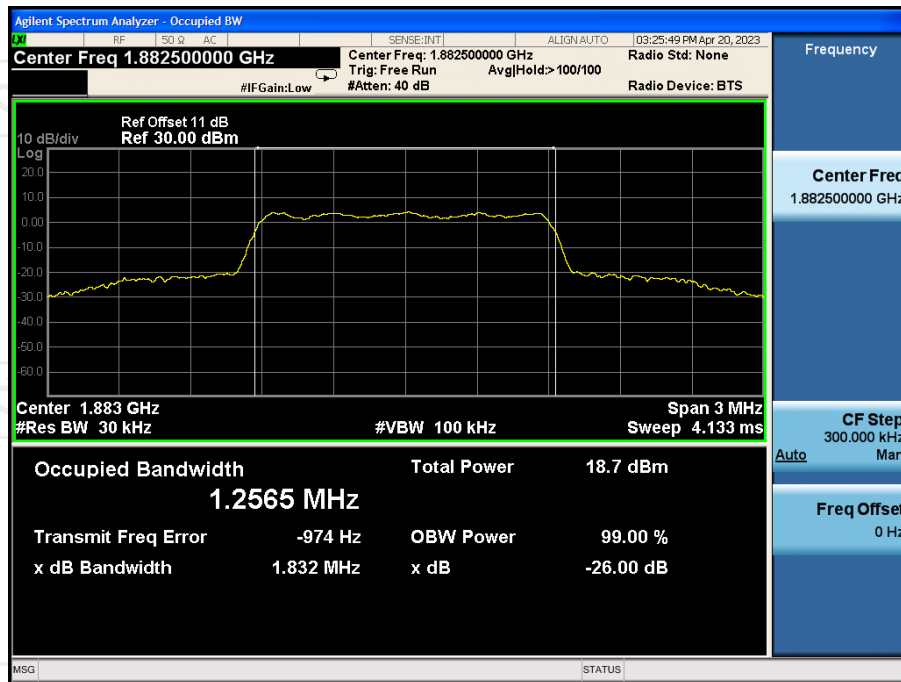

AWS-1 CDMA DL Input

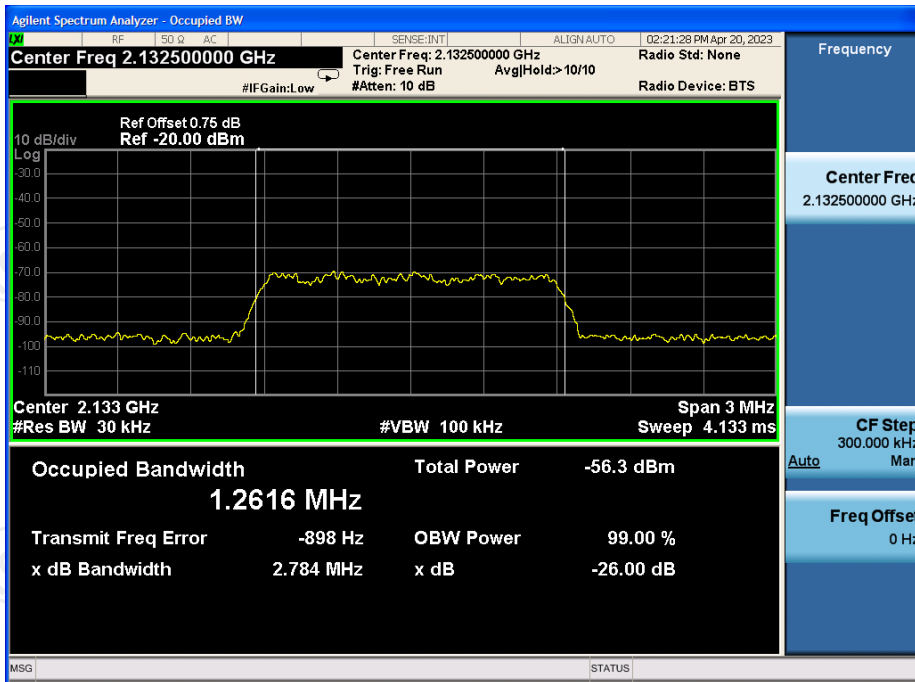

AWS-1 CDMA DL Output

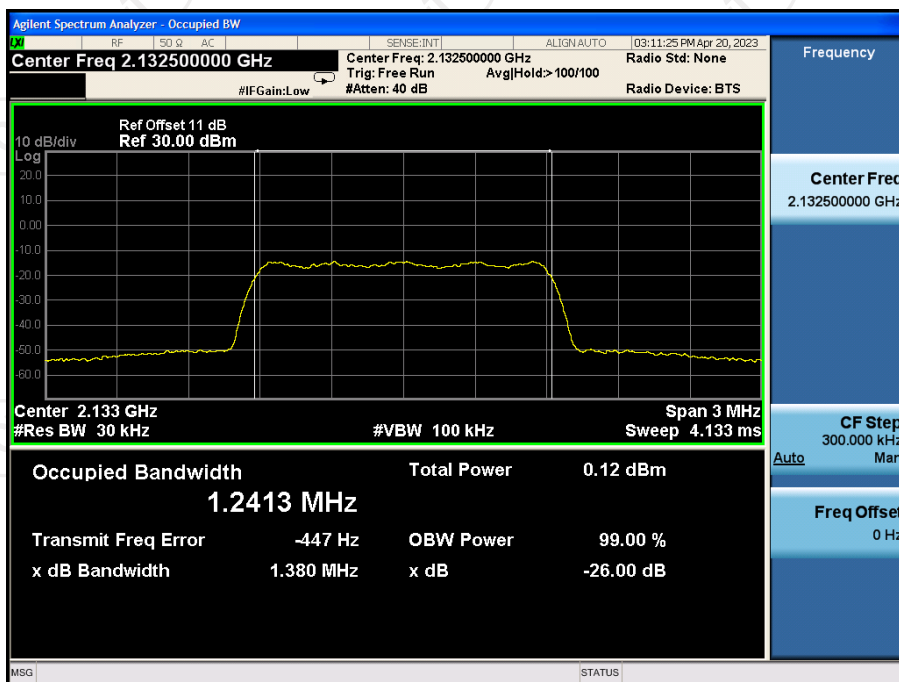

AWS-1 LTE UL Input

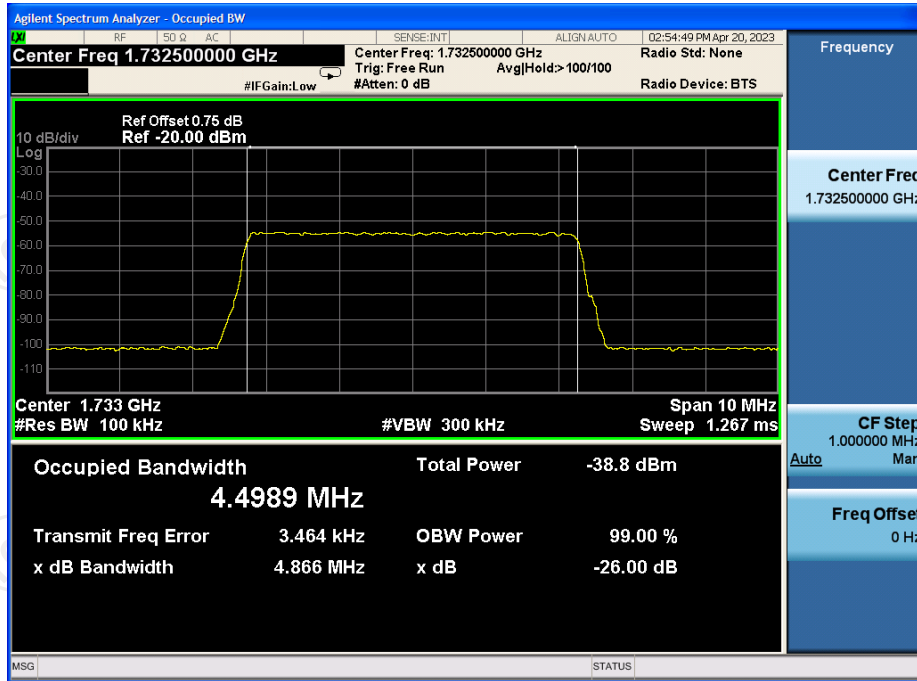

AWS-1 LTE UL output

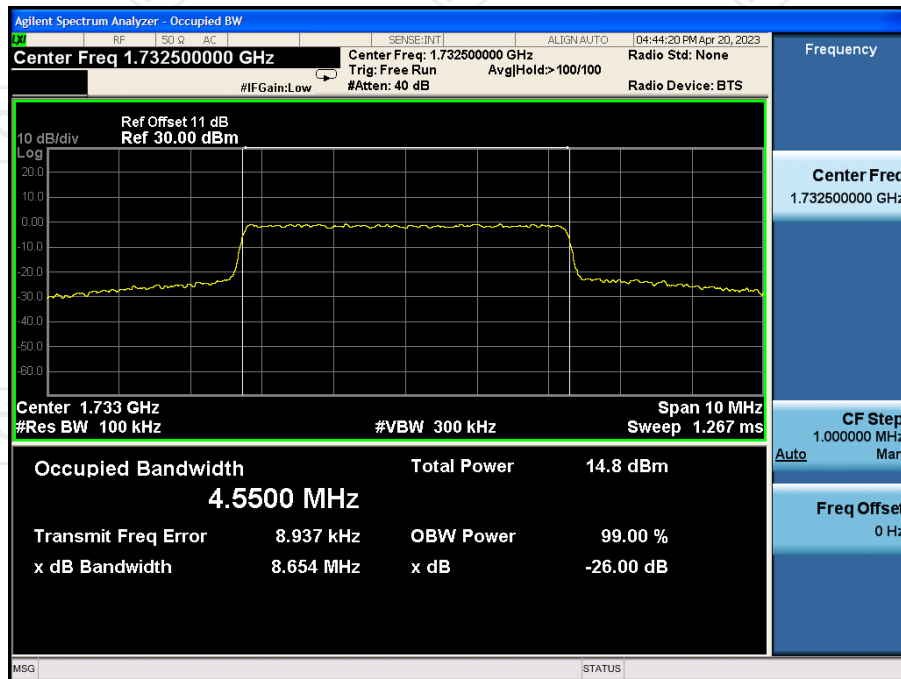

AWS-1 LTE DL Input

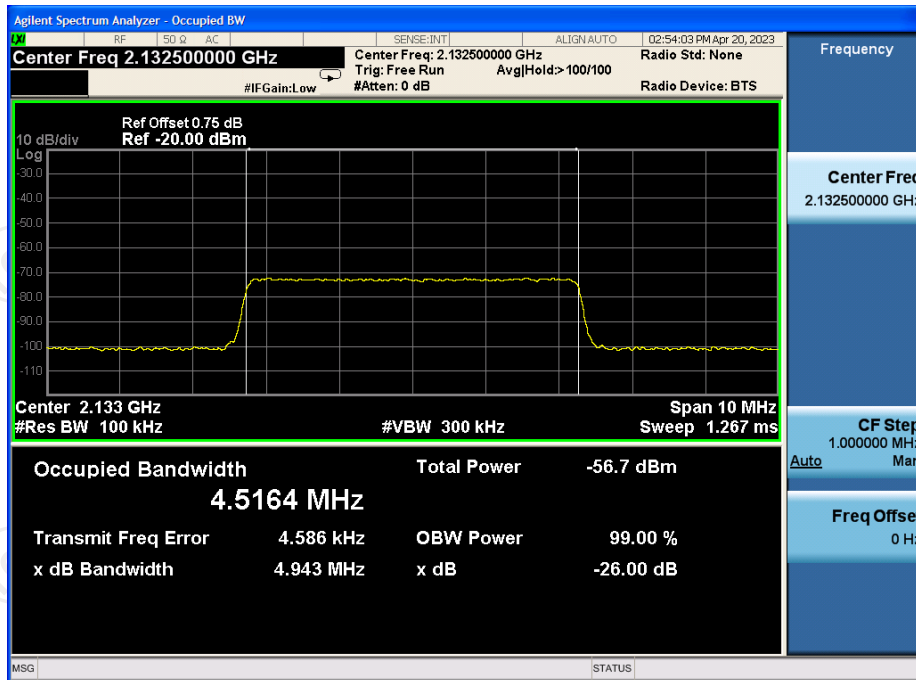

AWS-1 LTE DL Output

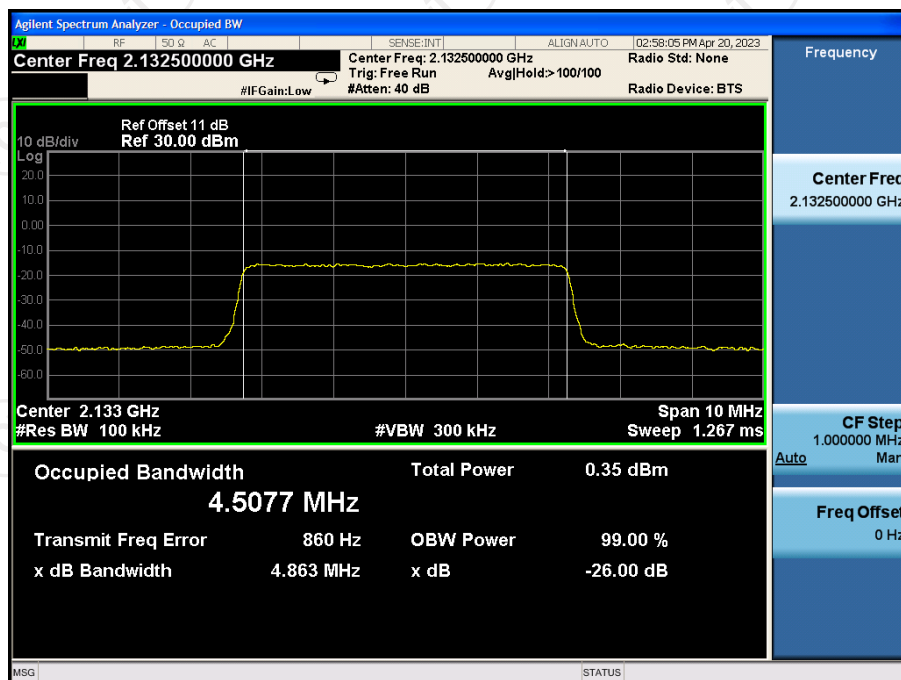

Cellular GSM UL Input

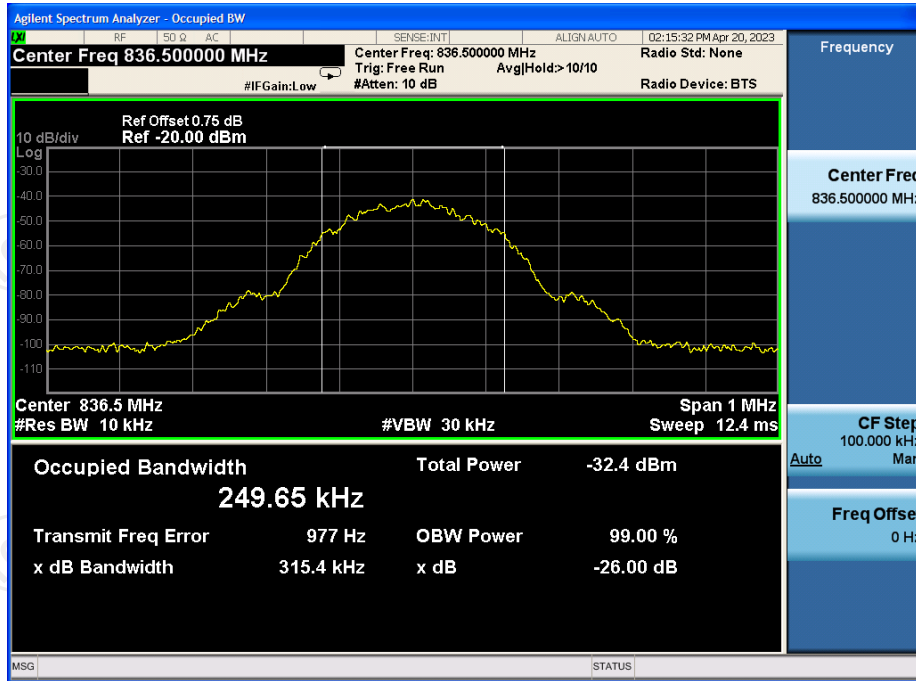

Cellular GSM UL output

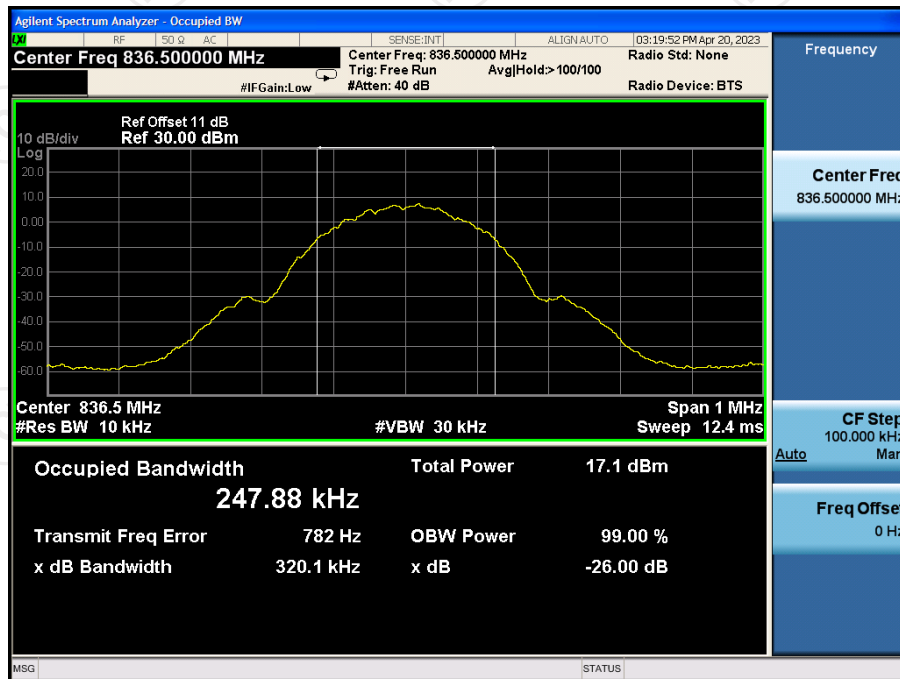

Cellular GSM DL Input

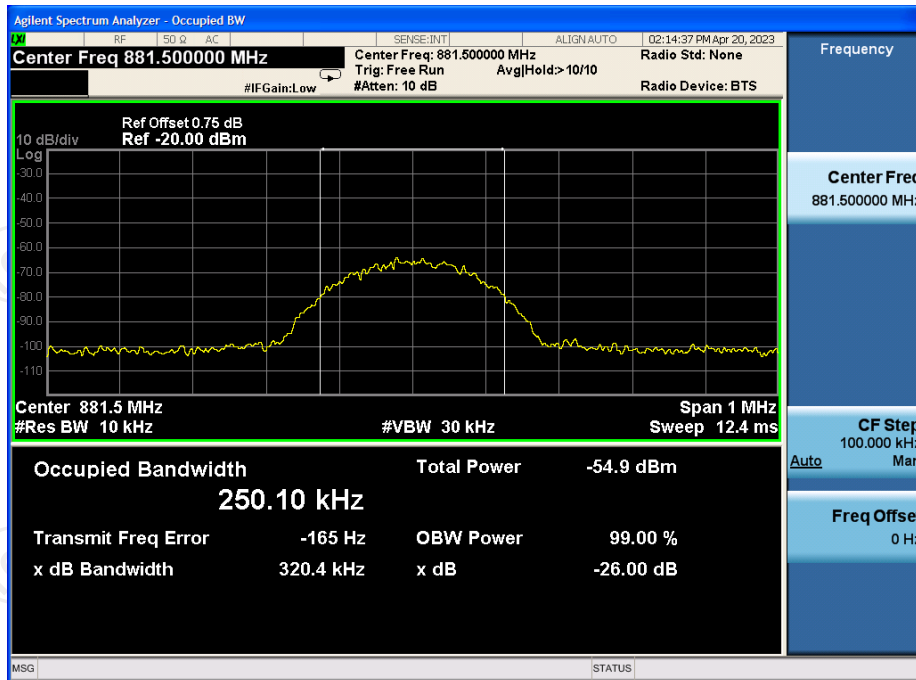

Cellular GSM DL Output

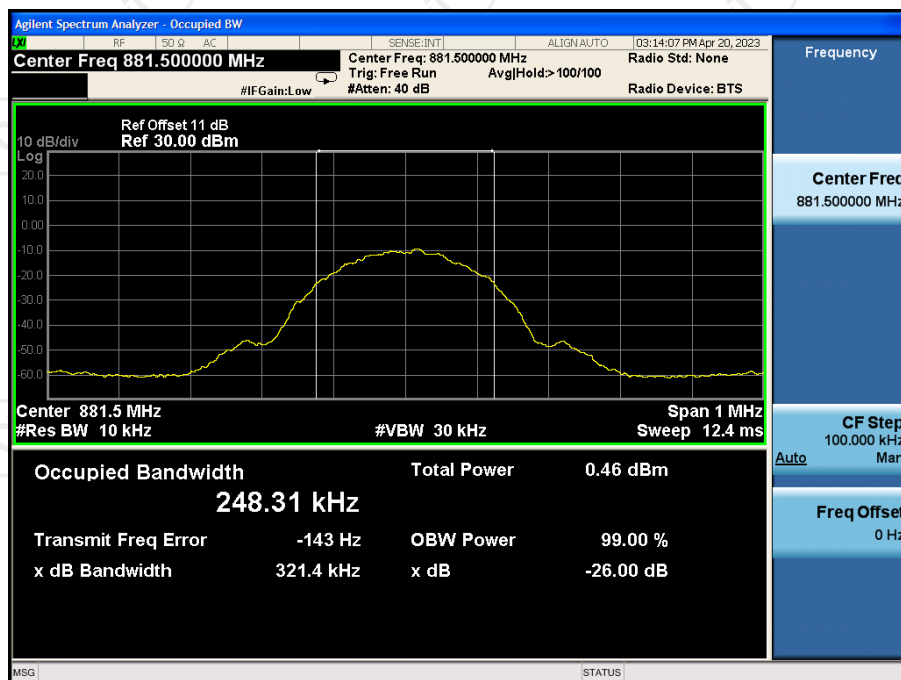

Cellular CDMA UL Input

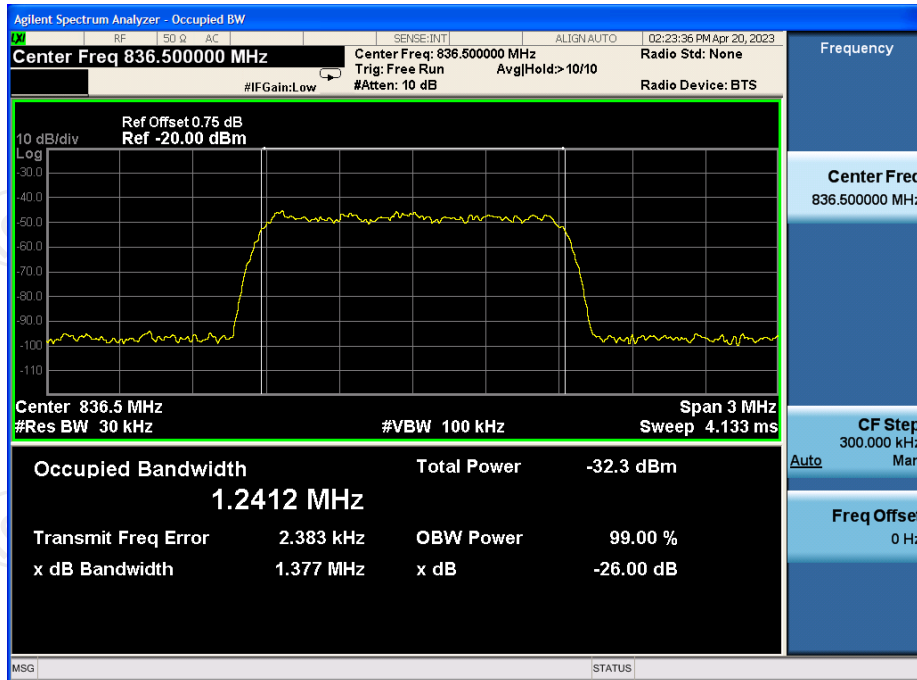

Cellular CDMA UL output

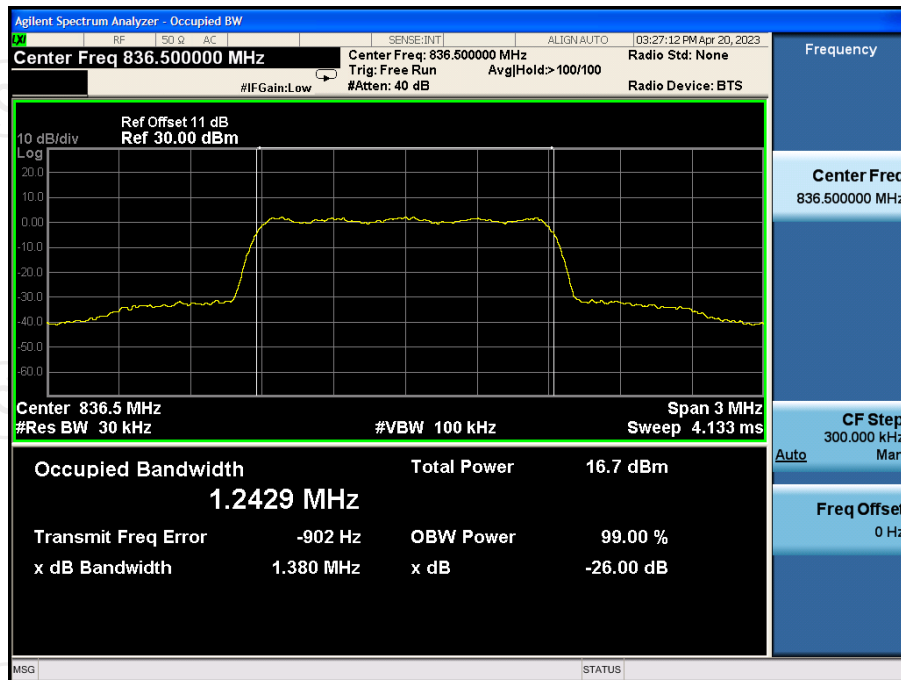

Cellular CDMA DL Input

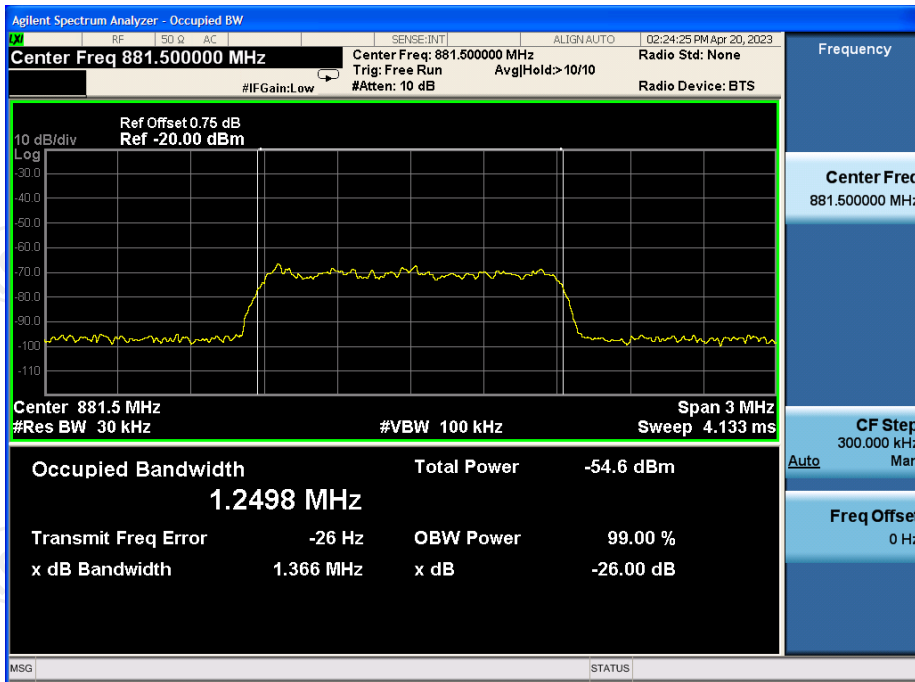

Cellular CDMA DL Output

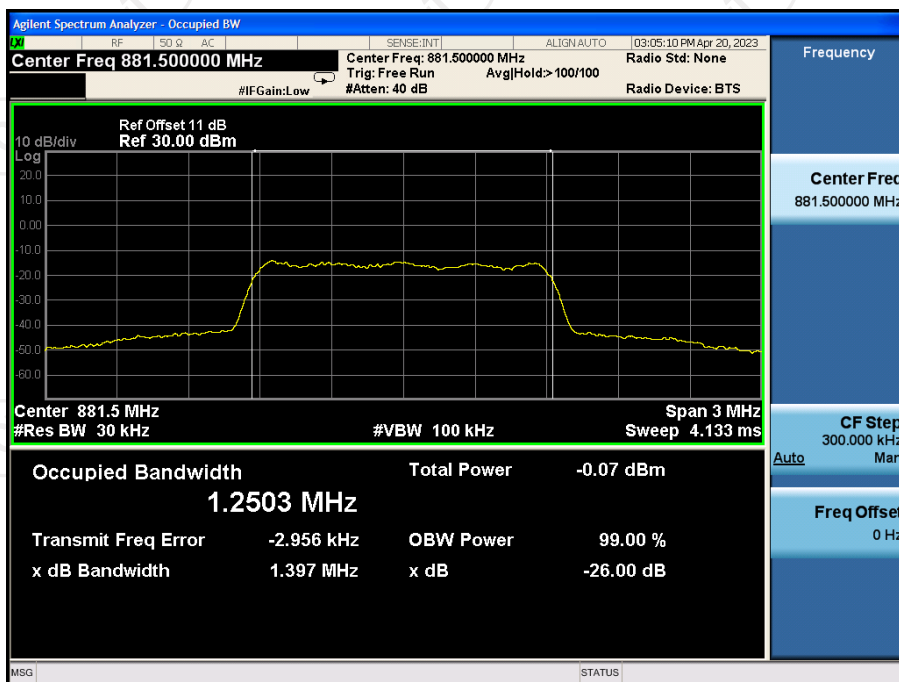

Cellular LTE UL Input

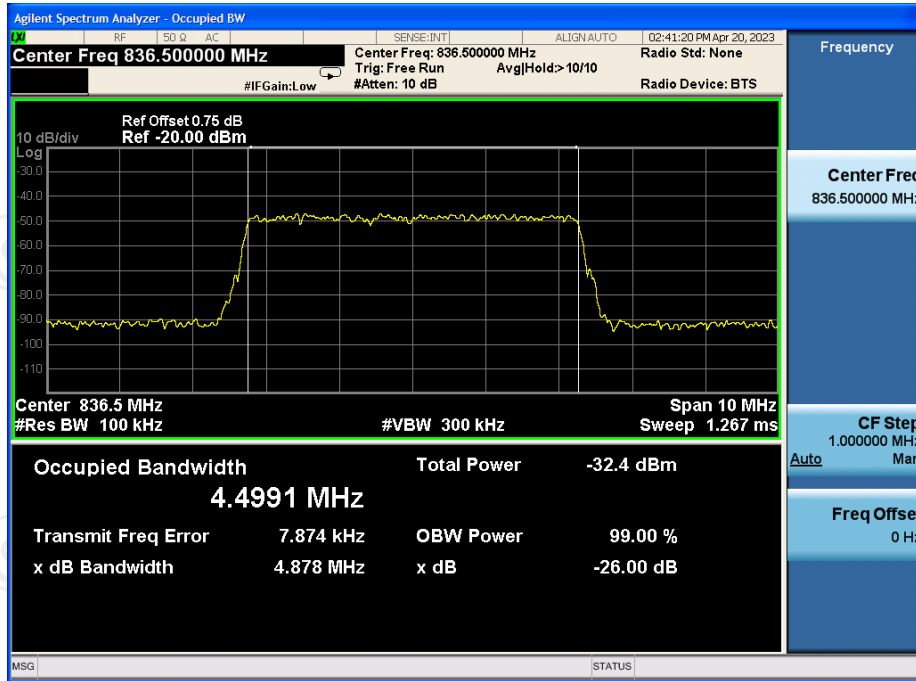

Cellular LTE UL output

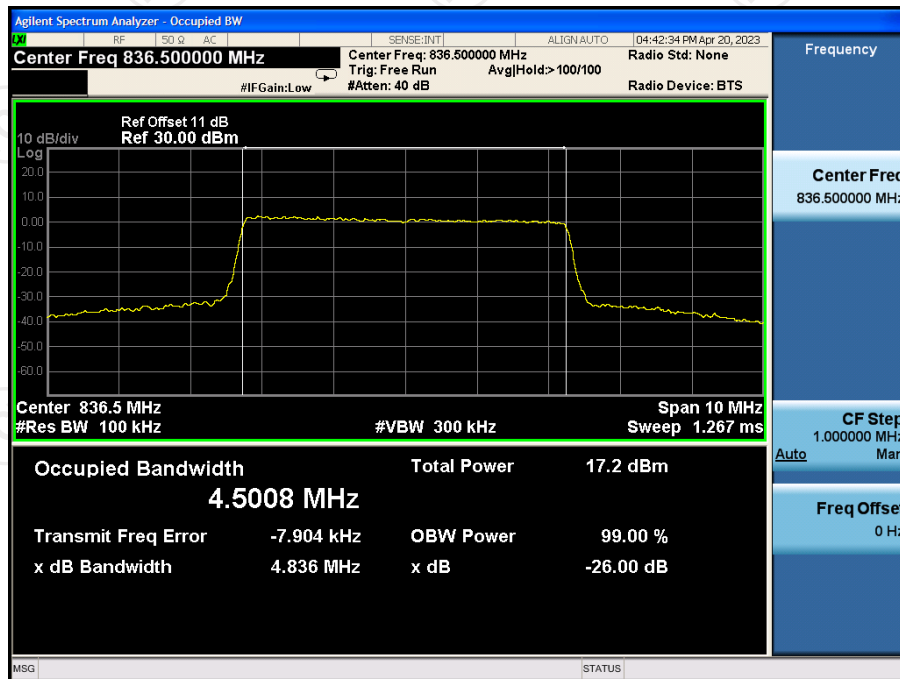

Cellular LTE DL Input

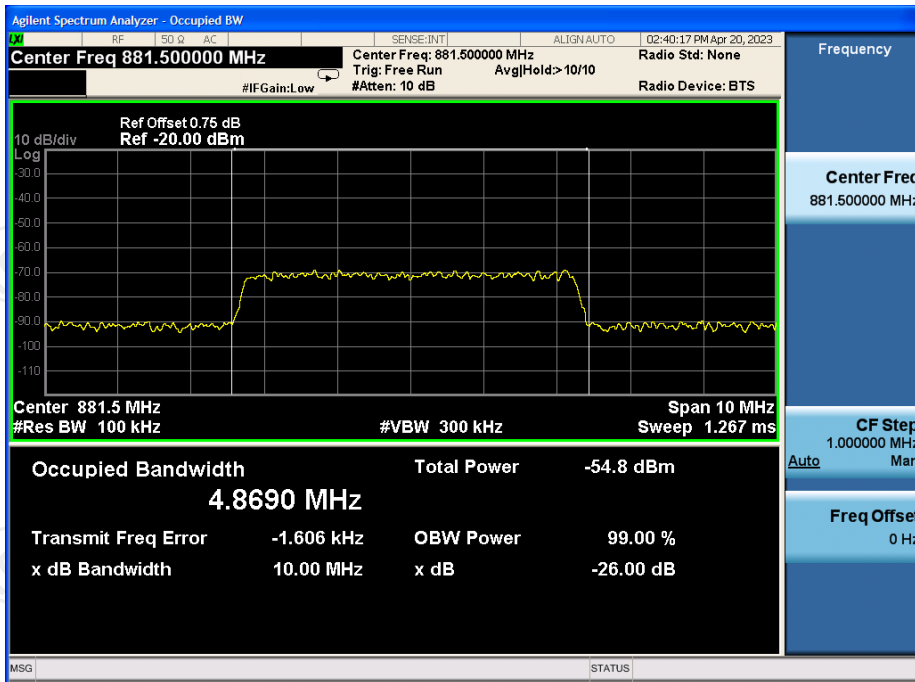

Cellular LTE DL Output

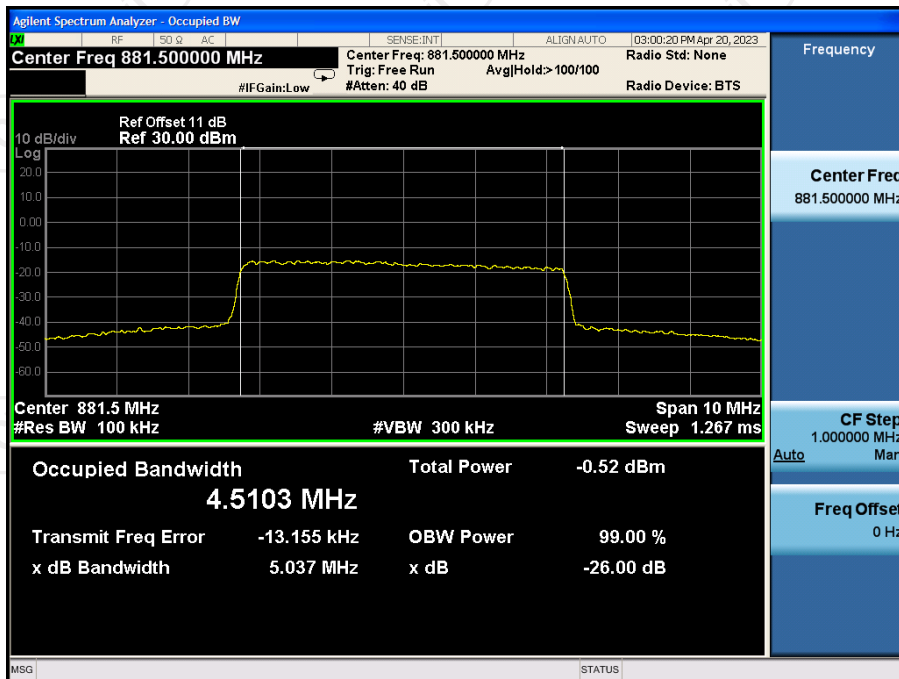

Lower700MHz GSM UL Input

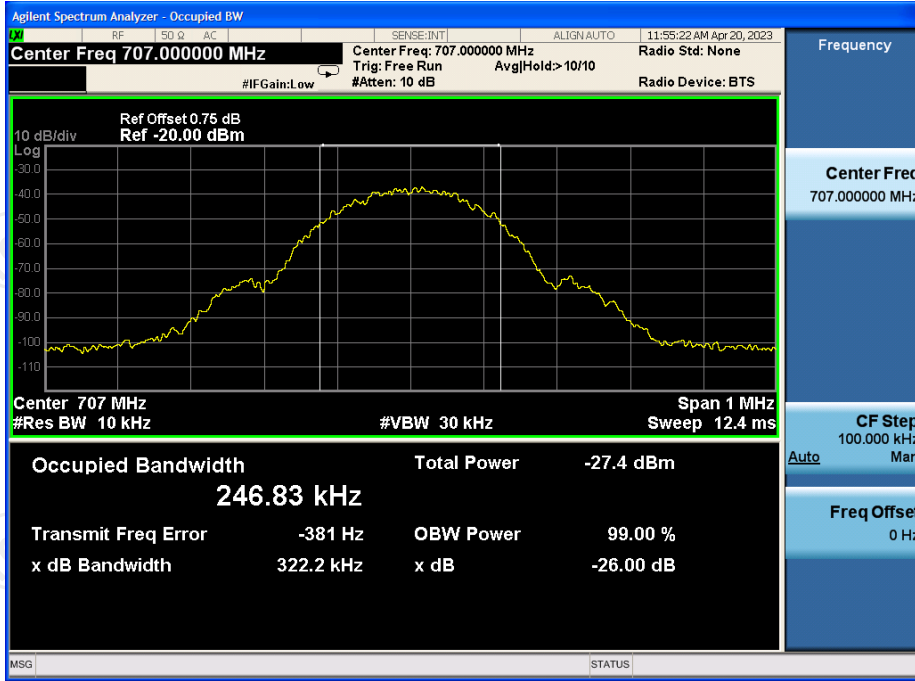

Lower700MHz GSM UL output

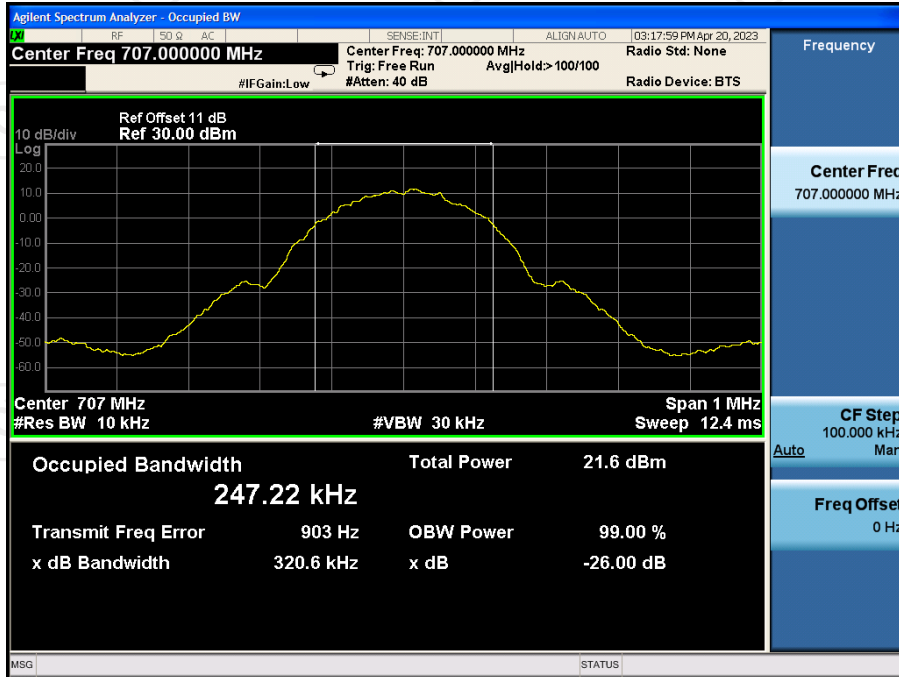

Lower700MHz GSM DL Input

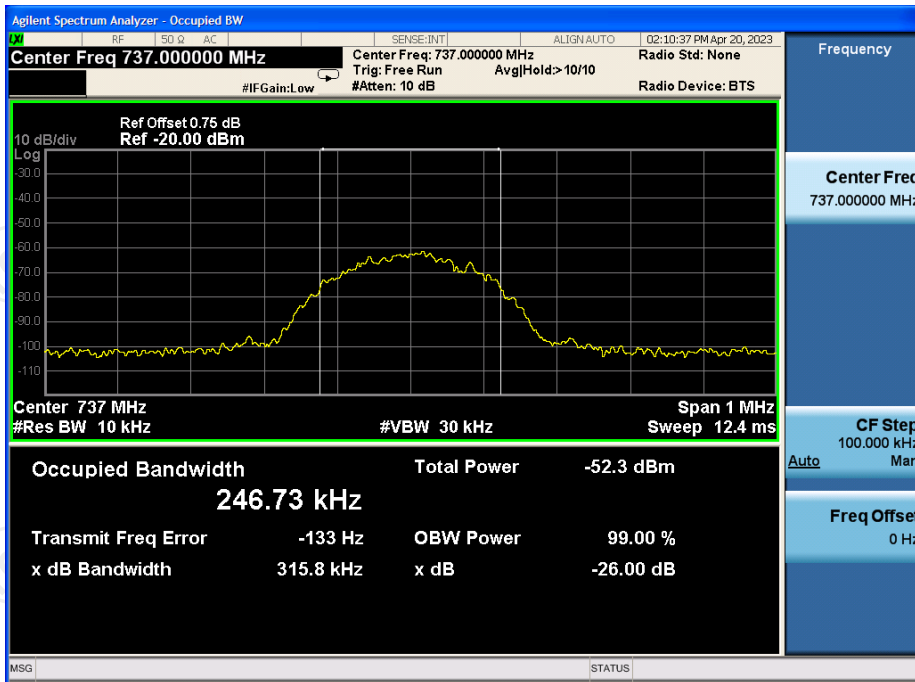

Lower700MHz GSM DL Output

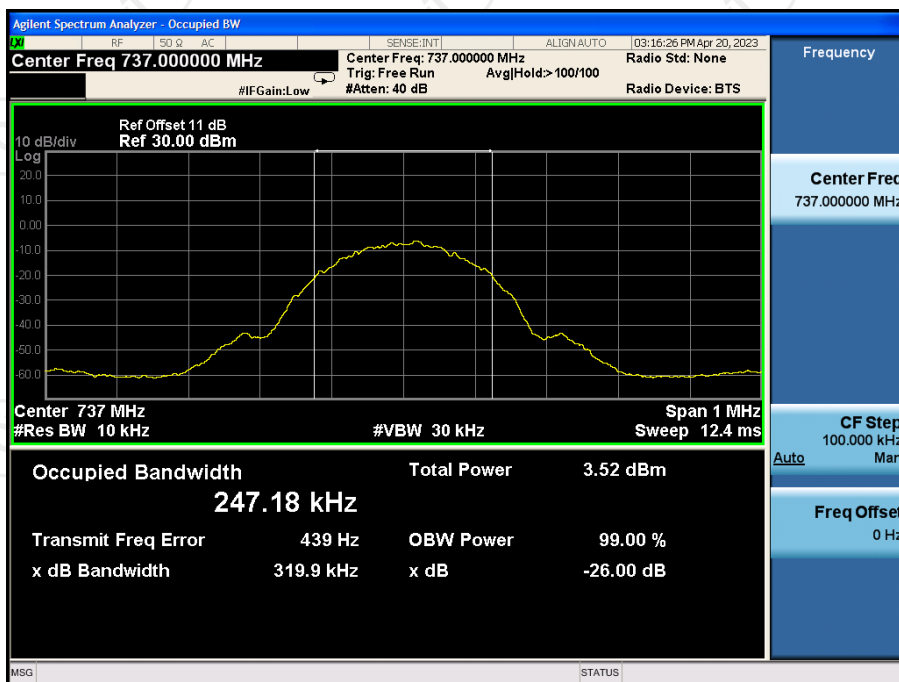

Lower700MHz CDMA UL Input

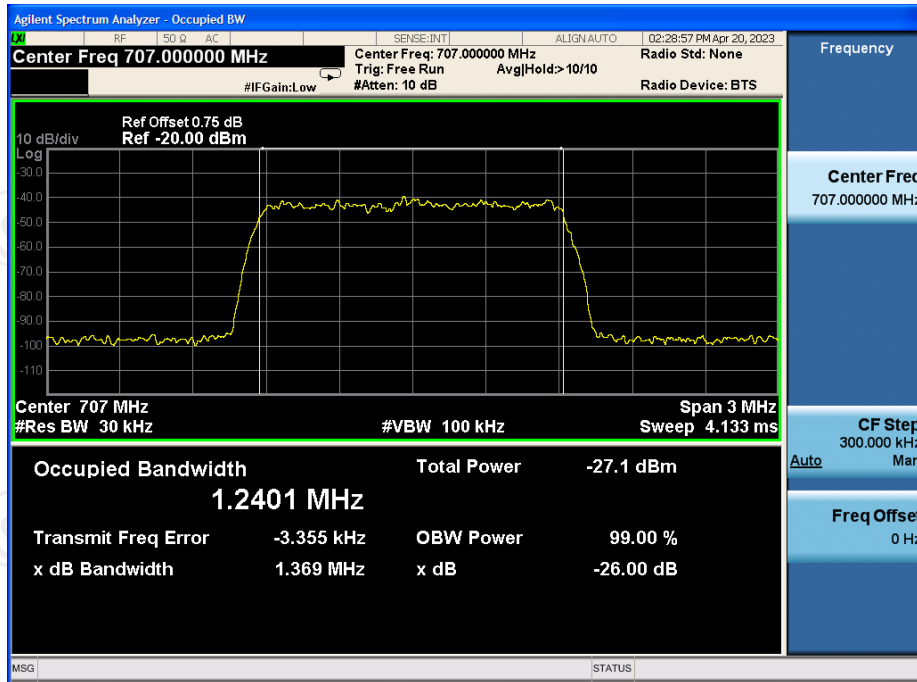

Lower700MHz CDMA UL output

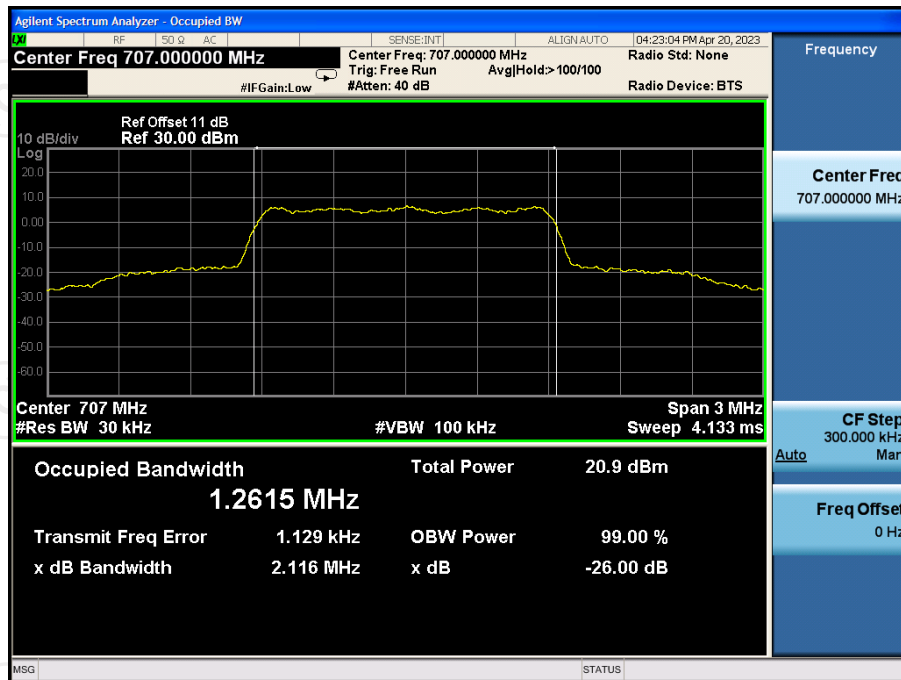

Lower700MHz CDMA DL Input

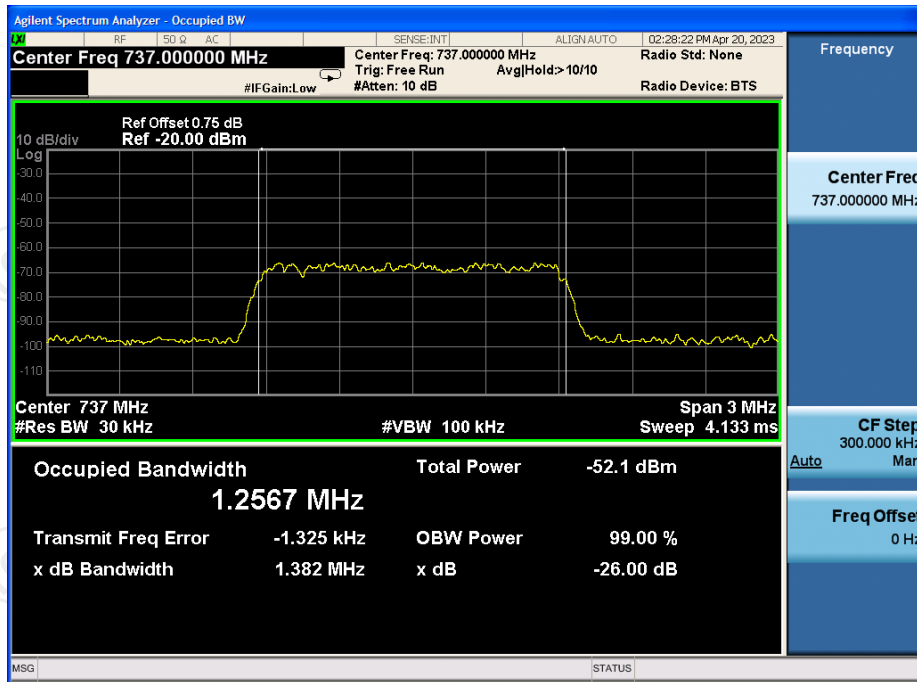

Lower700MHz CDMA DL Output

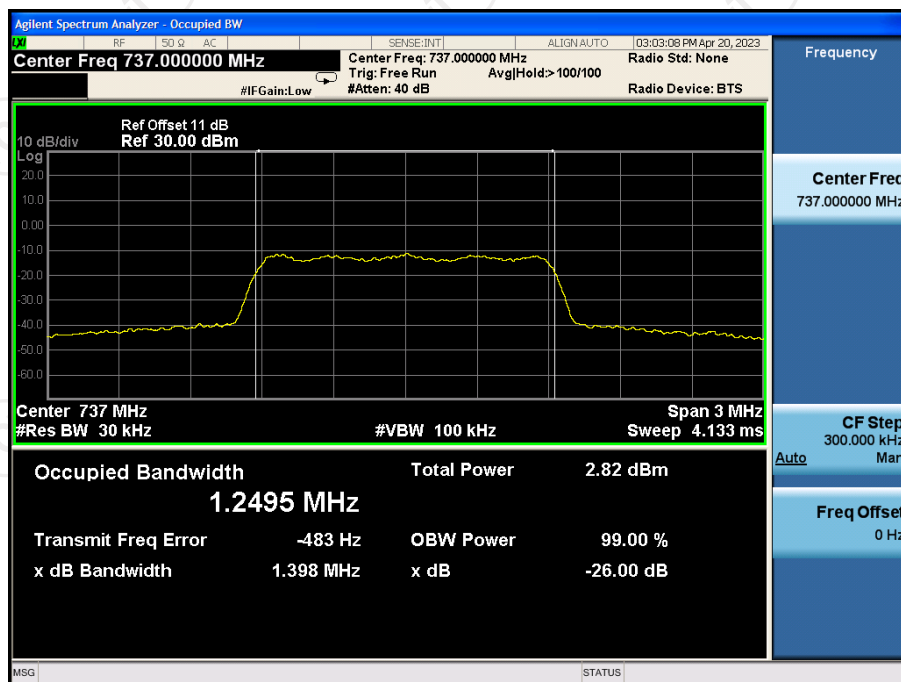

Lower700MHz LTE UL Input

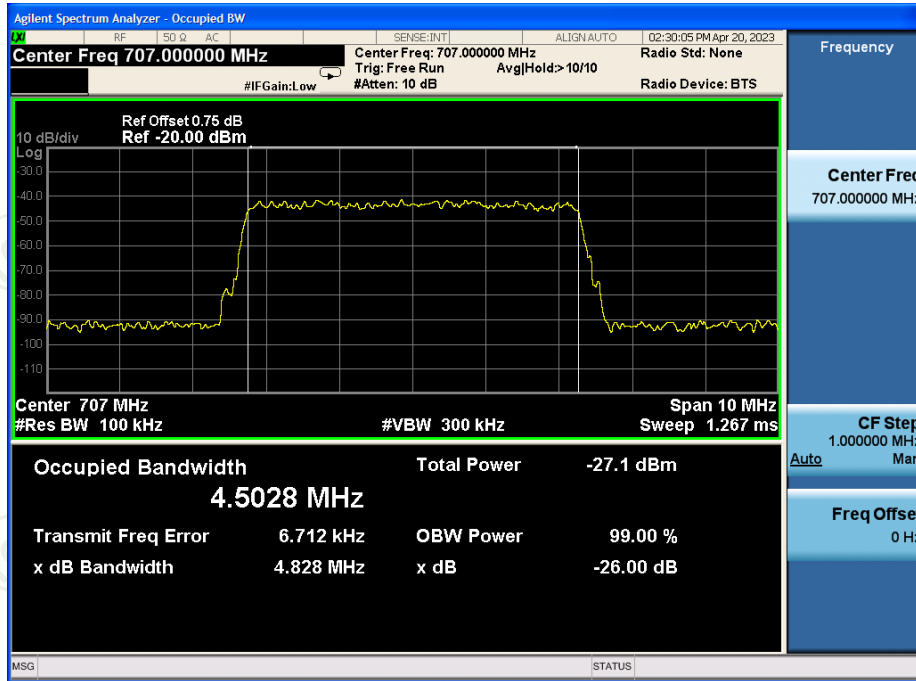

Lower700MHz LTE UL output

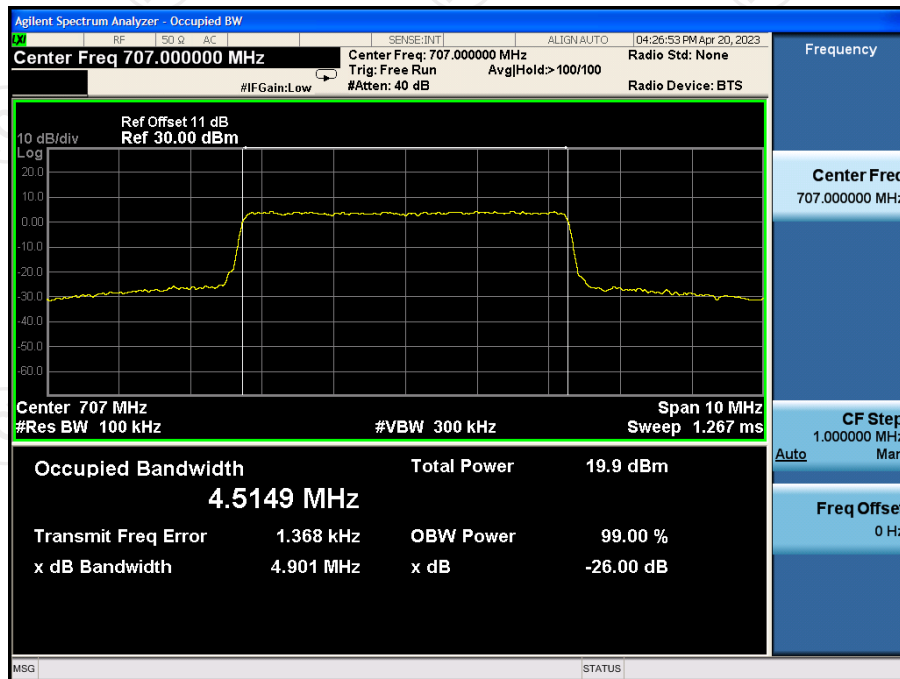

Lower700MHz LTE DL Input

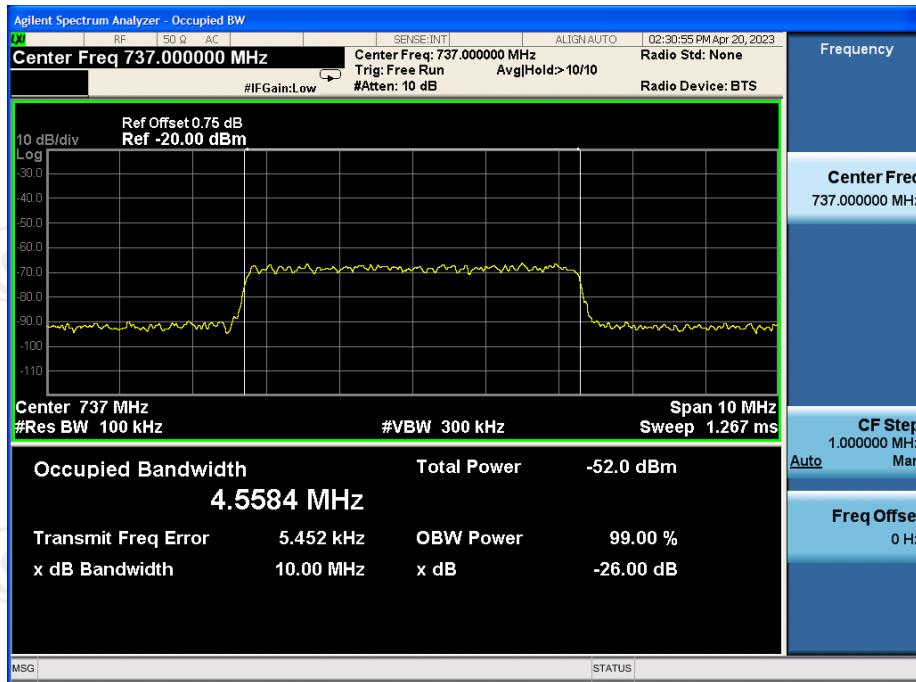

Lower700MHz LTE DL Output

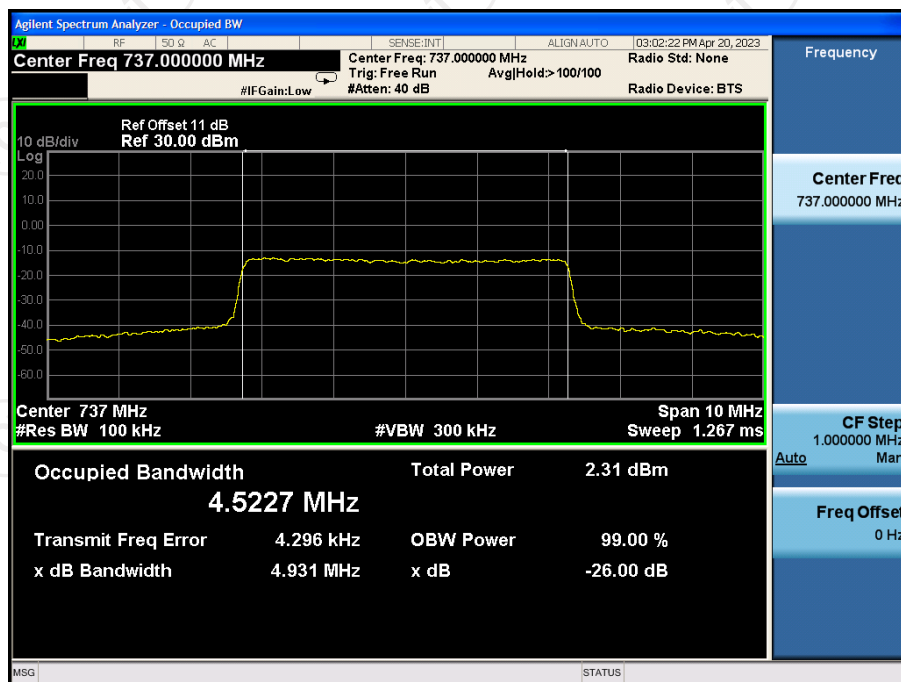

Upper700MHz GSM UL Input

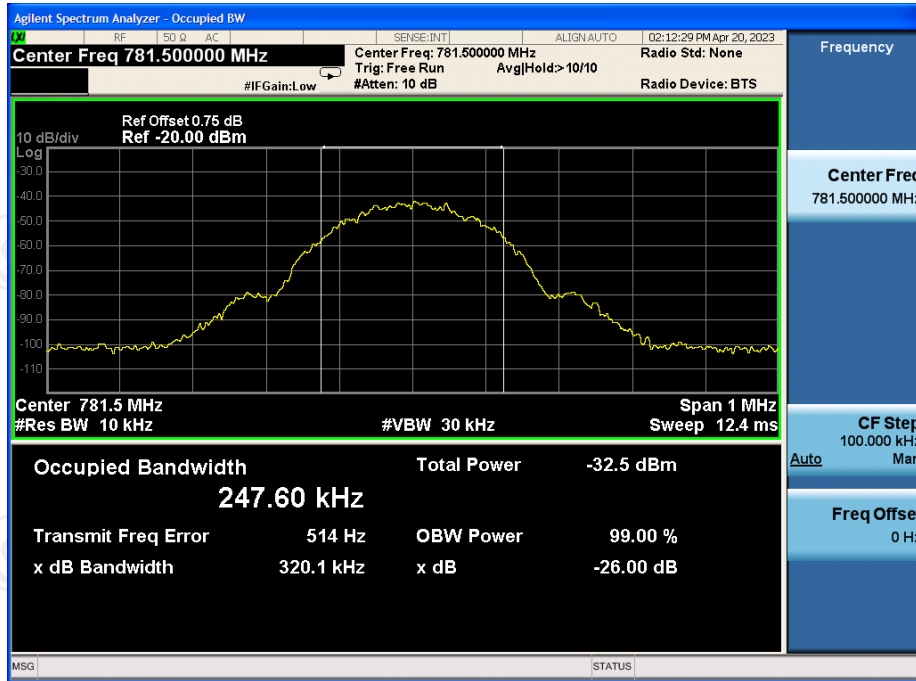

Upper700MHz GSM UL output

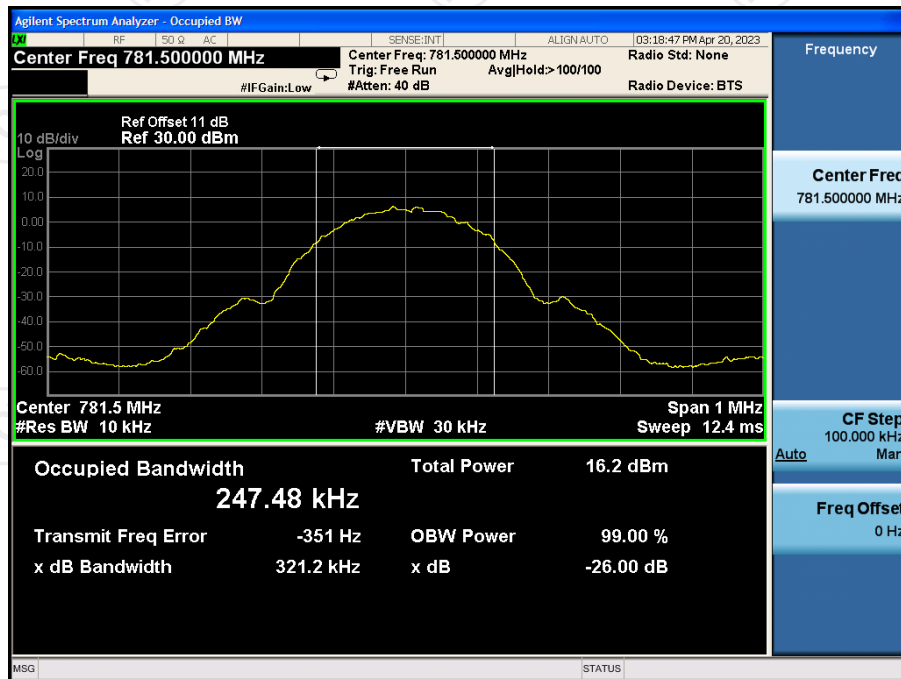

Upper700MHz GSM DL Input

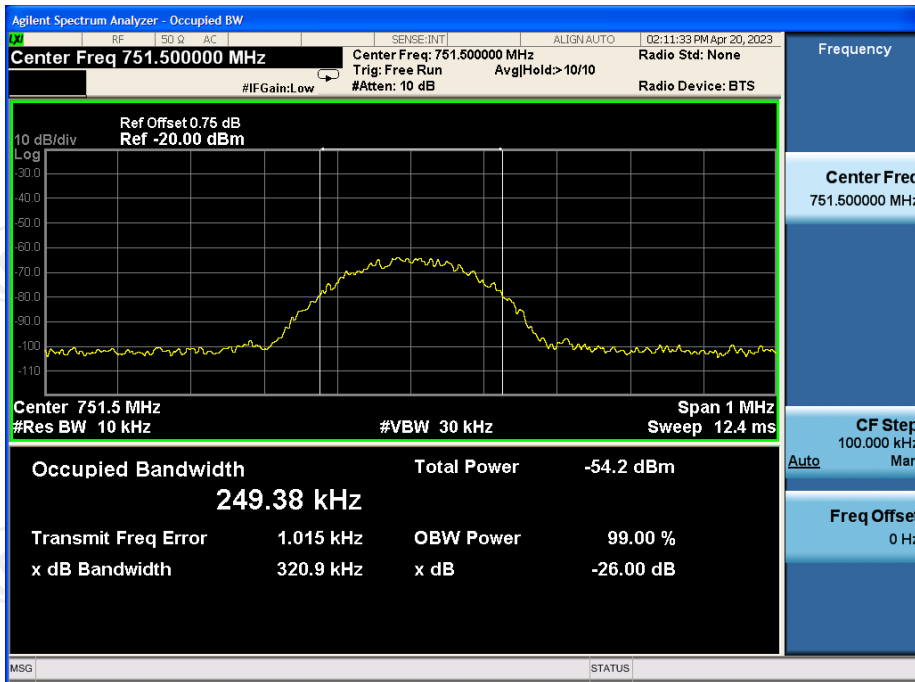

Upper700MHz GSM DL Output

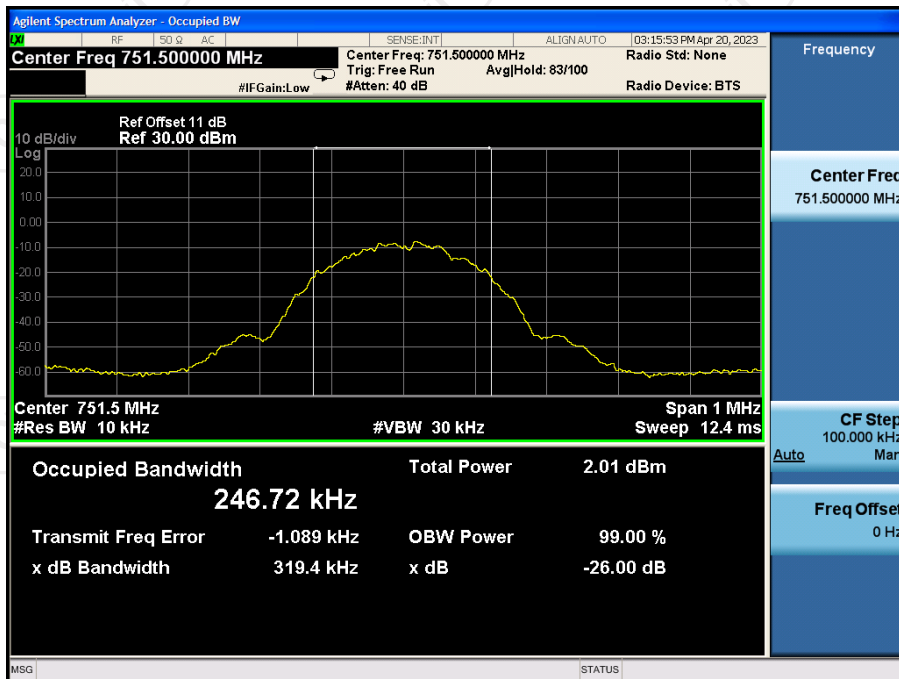

Upper700MHz CDMA UL Input

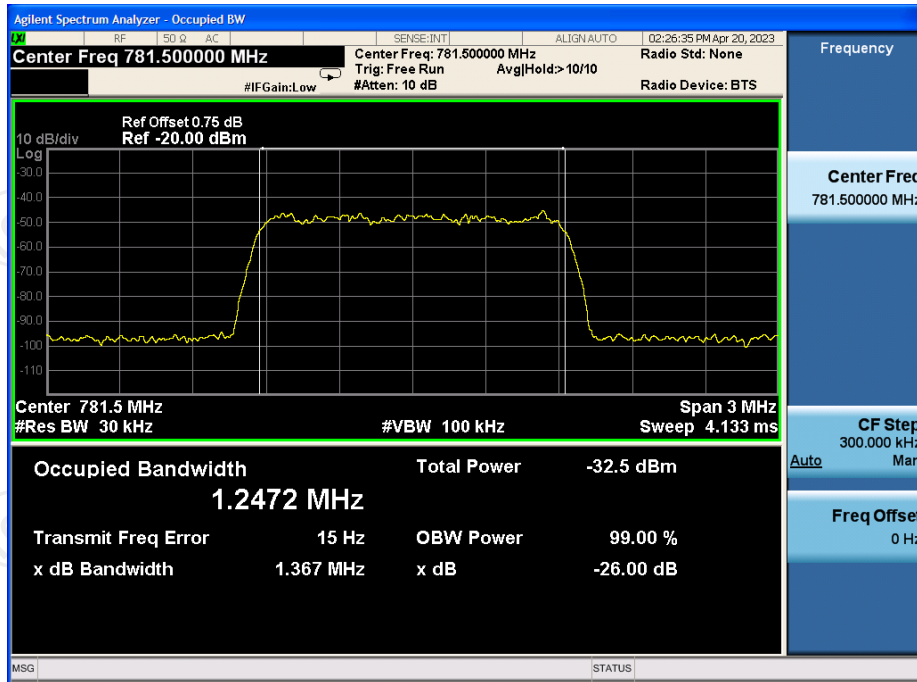

Upper700MHz CDMA UL output

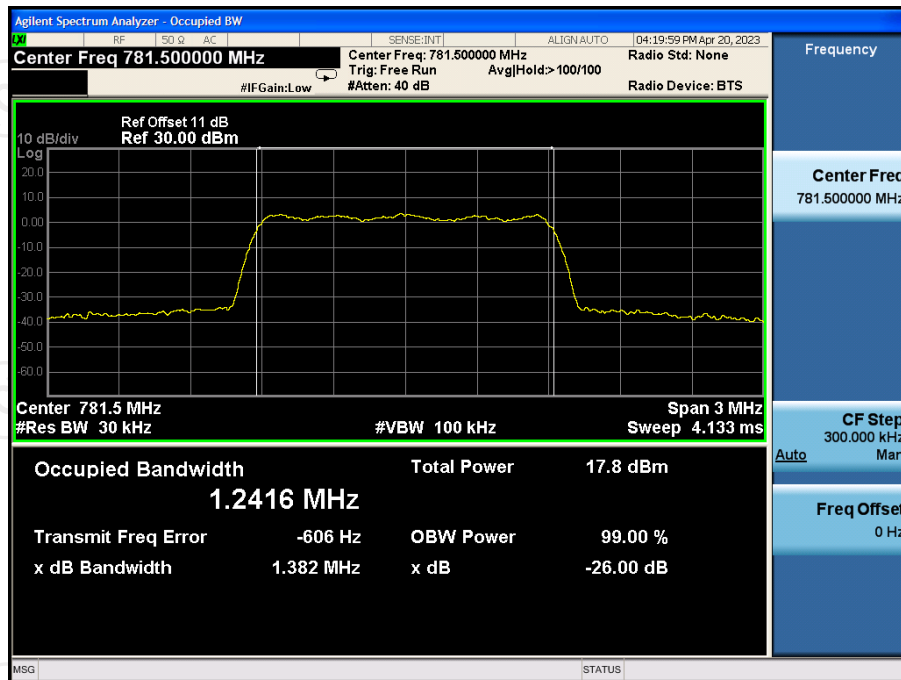

Upper700MHz CDMA DL Input

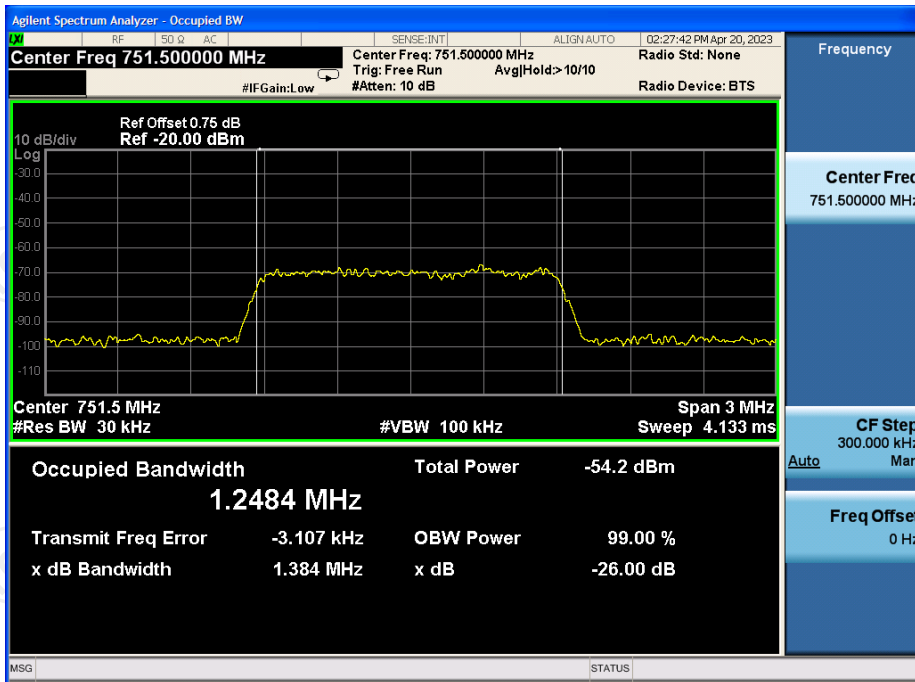

Upper700MHz CDMA DL Output

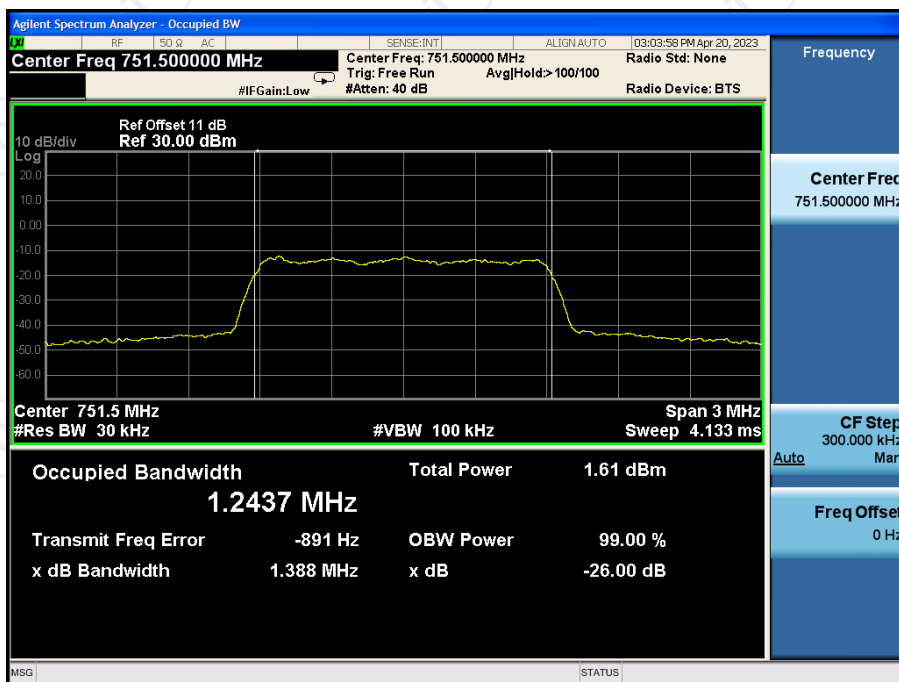

Upper700MHz LTE UL Input

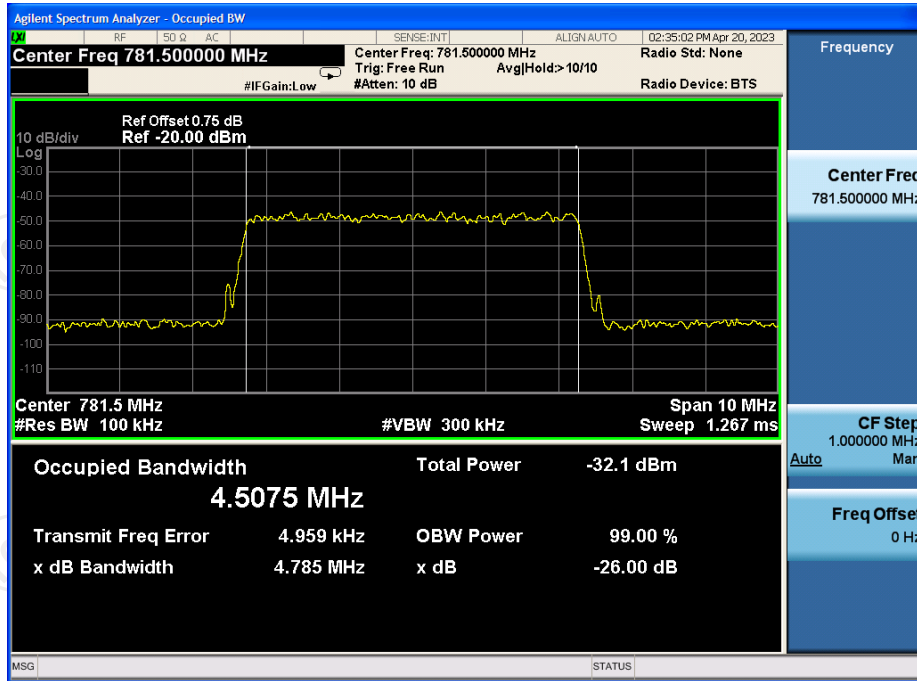

Upper700MHz LTE UL output

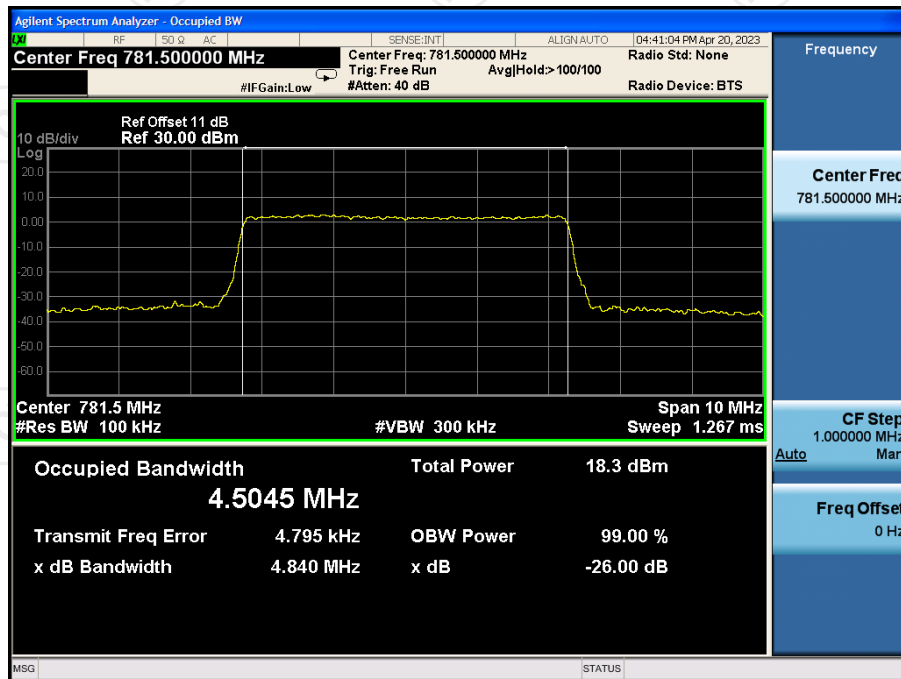

Upper700MHz LTE DL Input

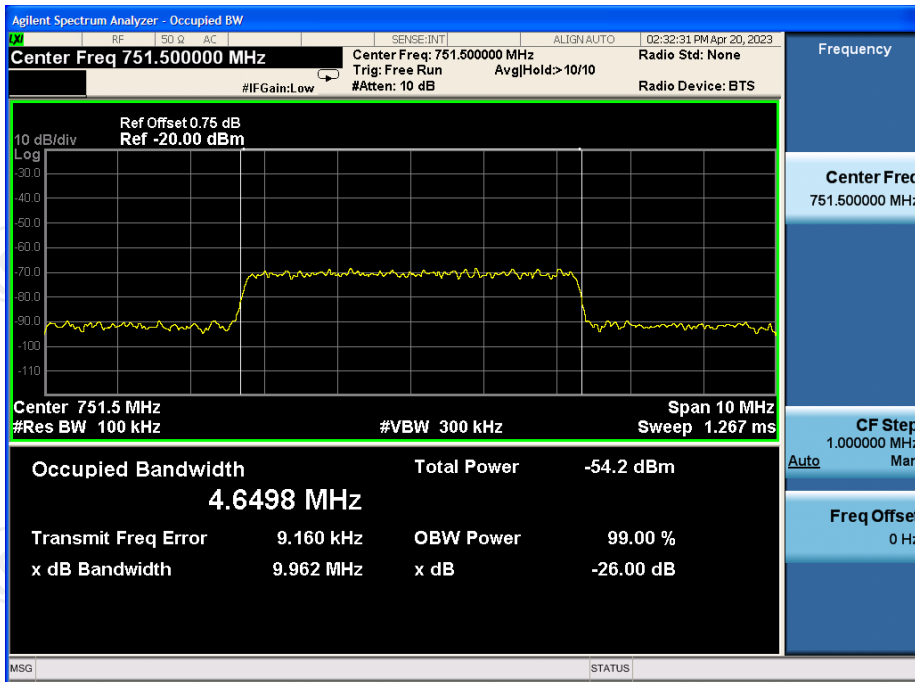

Upper700MHz LTE DL Output

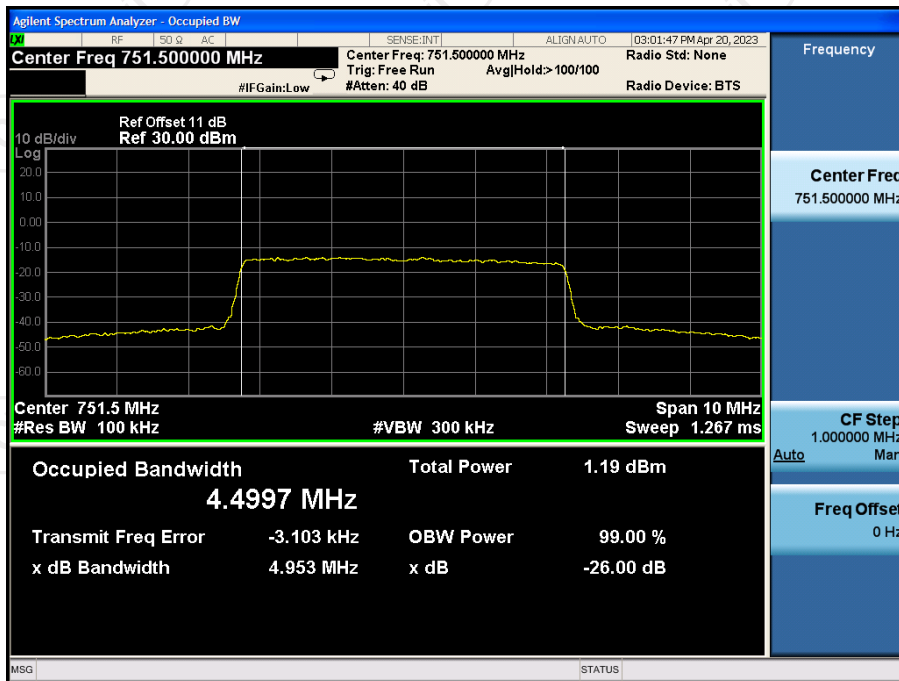

5.10. Oscillation Detection and Mitigation

5.10.1. Test Specification

Test Requirement:	FCC Part20 Section 20.21(e)(8)(ii)(A)
Test Method:	KDB935210 D03 Signal booster Measurements v04r04
Limit:	Reference to test data bellow

Test setup:

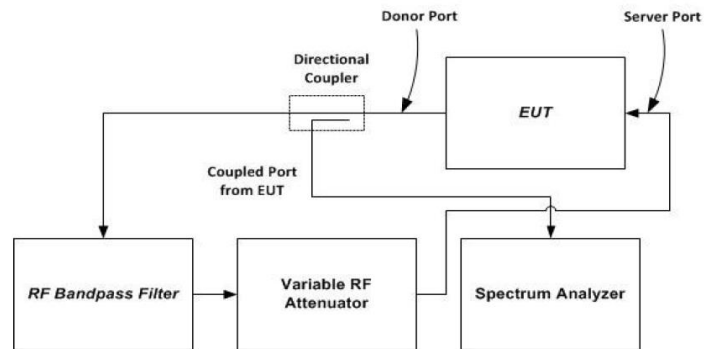

NOTE—This figure shows the test setup for uplink bands transmission path tests; i.e., signal flow is out from the donor port into the directional coupler. For downlink bands transmission path tests, the feedback signal flow path direction and equipment connections shall be reversed, i.e., signal flow is out from the server port into the directional coupler, and signal flow is into the donor port from the variable RF attenuator.

Figure 7 – Oscillation detection (7.11.2) test setup

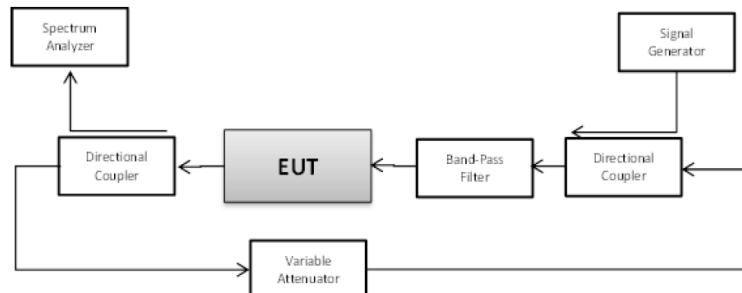

Figure 8 – Oscillation mitigation/shutdown test setup

Test Procedure:

Oscillation restart tests

- a) Connect the normal-operating mode EUT to the test equipment as shown in Figure 7 beginning with the spectrum analyzer on the uplink output (donor) port. Confirm that the RF coupled path is connected to the spectrum analyzer.
NOTE—The band-pass filter shall provide sufficient out-of-band rejection to prevent oscillations from occurring in bands not under test.
- b) Spectrum analyzer settings:
 - 1) Center frequency at the center of the band under test
 - 2) Span equal or slightly exceeding the width of the band under test
 - 3) Continuous sweep, max-hold
 - 4) RBW \geq 1 MHz, VBW > 3xRBW
- c) Decrease the variable attenuator until the spectrum analyzer displays a signal within the band under test. Using a marker, identify the approximate center frequency of this signal on the max-hold display, increase the attenuation by 10 dB, then reset the EUT (e.g., cycle ac/dc power).
- d) Repeat 7.11.2c) twice to ensure that the center of the signal

- created by the booster remains within 250 kHz of the spectrum analyzer display center frequency. If the frequency of the signal is unstable, confirm that the spectrum analyzer display is centered between the frequency extremes observed. If the signal is wider than 1 MHz, ensure that the spectrum analyzer display is centered on the signal by increasing the RBW. Reset the EUT (e.g., cycle ac/dc power) after each oscillation event, if necessary. Set the spectrum analyzer sweep trigger level to just below the peak amplitude of the displayed EUT oscillation signal.
- e) Set the spectrum analyzer to zero-span, with a sweep time of 5 seconds, and single-sweep with max-hold. The spectrum analyzer sweep trigger level in this and the subsequent steps shall be the level identified in 7.11.2d).
 - f) Decrease the variable attenuator until the spectrum analyzer sweep is triggered, increase the attenuation by 10 dB, then reset the EUT (e.g., cycle ac/dc power).
 - g) Reset the zero-span trigger of the spectrum analyzer, then repeat 7.11.2f) twice to ensure that the spectrum analyzer is reliably triggered, resetting the EUT (e.g., cycle ac/dc power) after each oscillation event if necessary.
 - h) Reset the zero-span sweep trigger of the spectrum analyzer, and reset the EUT (e.g., cycle ac/dc power).
 - i) Force the EUT into oscillation by reducing the attenuation.
 - j) Use the marker function of the spectrum analyzer to measure the time from the onset of oscillation until the EUT turns off, by setting Marker 1 on the leading edge of the oscillation signal and Marker 2 on the trailing edge. The spectrum analyzer sweep time may be adjusted to improve the time resolution of these cursors.
 - k) Capture the spectrum analyzer zero-span trace for inclusion in the test report. Report the power level associated with the oscillation separately if it can't be displayed on the trace.
 - l) Repeat 7.11.2b) to 7.11.2k) for all operational uplink and downlink bands.
 - m) Set the spectrum analyzer zero-span sweep time for longer than 60 seconds, then measure the restart time for each operational uplink and downlink band.
 - n) Replace the normal-operating mode EUT with the EUT that supports an anti-oscillation test mode.
 - o) Set the spectrum analyzer zero-span time for a minimum of 120 seconds, and a single sweep.
 - p) Manually trigger the spectrum analyzer zero-span sweep, and manually force the booster into oscillation as described in 7.11.2i).
 - q) When the sweep is complete, place cursors between the first two oscillation detections, and save the Test Plots for inclusion in the test report. The time between restarts must match the manufacturer's timing for the test mode, and there shall be no more than 5 restarts.
 - r) Repeat 7.11.2m) to 7.11.2q) for all operational uplink and downlink bands.

Test procedure for measuring oscillation mitigation or shutdown

- a) Connect the normal-operating mode EUT to the test equipment as shown in Figure 8.
- b) Set the spectrum analyzer center frequency to the center of band under test, and use the following settings:
 - 1) RBW=30 kHz, VBW $\geq 3 \times$ RBW,
 - 2) power averaging (rms) detector,
 - 3) trace averages ≥ 100 ,
 - 4) span $\geq 120\%$ of operational band under test

	<p>5) number of sweep points $\geq 2 \times \text{Span}/\text{RBW}$.</p> <p>c) Configure the signal generator for AWGN operation with a 99% OBW of 4.1 MHz, tuned to the frequency of 2.5 MHz above the lower edge or below the upper edge of the operating band under test. Adjust the RF output level of the signal generator such that the measured power level of the AWGN signal at the output port of the booster is 30 dB less than the maximum power of the booster for the band under test. Affirm that the input signal is not obstructing the measurement of the strongest oscillation peak in the band, and is not included within the span in the measurement.</p> <p>1) Boosters with operating spectrum passbands of 10 MHz or less may use a CW signal source at the band edge rather than AWGN.</p> <p>2) For device passbands greater than 10 MHz, standard CMRS signal sources (i.e., CDMA, W-CDMA, LTE) may be used instead of AWGN at the band edge.</p> <p>d) Set the variable attenuator to a high attenuation setting such that the booster will operate at maximum gain when powered on. Reset the the EUT (e.g., cycle ac/dc power). Allow the EUT to complete its boot-up process, to reach full operational gain, and to stabilize its operation.</p> <p>e) Set the variable attenuator such that the insertion loss for the center of the band under test (isolation) between the booster donor port and server port is 5 dB greater than the maximum gain, as recorded in the maximum gain test procedure (see 7.3), for the band under test.</p> <p>f) Verify the EUT shuts down, i.e., to mitigate the oscillations. If the booster does not shut down, measure and verify the peak oscillation level as follows.</p> <p>1) Allow the spectrum analyzer trace to stabilize.</p> <p>2) Place the marker at the highest oscillation level occurring within the span, and record its output level and frequency.</p> <p>3) Set the spectrum analyzer center frequency to the frequency with the highest oscillation signal level, and reduce the span such that the upper and lower adjacent oscillation peaks are within the span.</p> <p>4) Use the Minimum Search Marker function to find the lowest output level that is within the span, and within the operational band under test, and record its output level and frequency.</p> <p>5) Affirm that the peak oscillation level measured in 7.11.3f2), does not exceed by 12.0 dB the minimal output level measured in 7.11.3f4). Record the measurement results of 7.11.3f2) and 7.11.3f4) in tabular format for inclusion in the test report.</p> <p>6) The procedure of 7.11.3f1) to 7.11.3f5) allows the spectrum analyzer trace to stabilize, and verification of shutdown or oscillation level measurement must occur within 300 seconds.</p> <p>g) Decrease the variable attenuator in 1 dB steps, and repeat step 7.11.3f) for each 1 dB step. Continue testing to the level when the insertion loss for the center of band under test (isolation) between the booster donor port and server port is 5 dB lower than the maximum gain (see 7.3).</p> <p>h) Repeat 7.11.3a) to 7.11.3g) for all operational uplink and downlink bands.</p>
--	---

Test results:	PASS
----------------------	-------------

5.10.2. Test Instruments

Equipment	Manufacturer	Model	S/N	Calibration Date	Calibration Due
Spectrum Analyzer	Agilent	N9020A	MY49100619	Jul. 05, 2022	Jul. 04, 2023
Attenuation	AF115A-09-34	JFW	907763	/	/
RF Combiner	SUNVNDN	SUD-CS0800	16230009	/	/
AN03468	Band Pass Filter	4CS10-781.5/E12.2-O/O	/	/	/
AN03469	Band Pass Filter	4CS10-751.5/E12-O/O	/	/	/
AN02475	1 dB step Attenuator	8494B	/	/	/
AN03429	10dB step Attenuator	8496B	/	/	/
ANC00082	RF Coupler	722-10-1.500V	/	/	/

5.10.3. Test Data

Test results of detection time				
Operation Bands		Detection Time (s)	Limit (s)	Result
Uplink	PCS	0.213	0.300	PASS
	AWS-1	0.045	0.300	PASS
	Cellular	0.095	0.300	PASS
	Lower700MHz	0.030	0.300	PASS
	Upper700MHz	0.035	0.300	PASS
Downlink	PCS	0.220	1.000	PASS
	AWS-1	0.173	1.000	PASS
	Cellular	0.140	1.000	PASS
	Lower700MHz	0.163	1.000	PASS
	Upper700MHz	0.133	1.000	PASS

Test results of restarting time						
Operation Bands		Restarting Time(s)	Limit (s)	Restarting Counts	Limit	Result
Uplink	PCS	65.70	60	1	5	PASS
	AWS-1	65.70	60	1	5	PASS
	Cellular	66.41	60	1	5	PASS
	Lower700MHz	/	60	0	5	PASS
	Upper700MHz	/	60	0	5	PASS
Downlink	PCS	66.60	60	3	5	PASS
	AWS-1	65.72	60	3	5	PASS
	Cellular	65.70	60	3	5	PASS
	Lower700MHz	65.70	60	3	5	PASS
	Upper700MHz	65.40	60	3	5	PASS