

APlusBoost

A SUNFORD ELECTRONICS BRAND

Home MultiRoom

Cell Phone Signal Booster

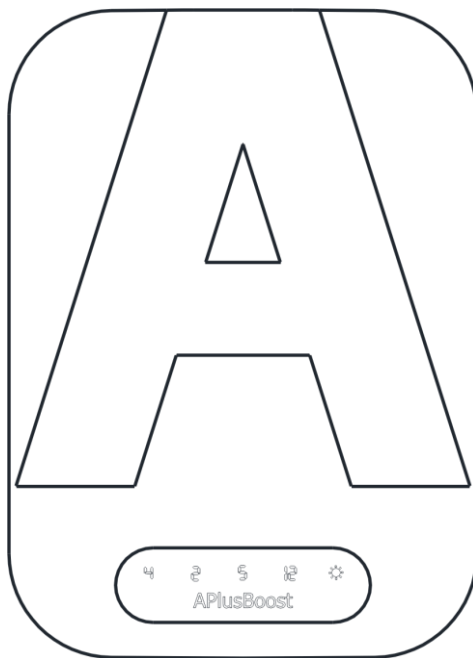

Installation Guide

NEED HELP ?

 www.aplusboost.com

CATALOG

Package Contents	1
Preparation	2
STEP 1: Inside Antenna Placement	3
STEP 2: Mount & Point Outside Antenna Toward Nearest Cell Tower	5
STEP 3: Route & Connect Outside Antenna To Booster	7
STEP 3: Route & Connect Inside Antenna To Booster	8
STEP 4: Power Up The Booster & Optimize The System	9
Measuring Booster Performance	10
Light Patterns	12
Troubleshooting	13
Safety Guidelines	15
Specifications	16
Warranty	17

Package Contents

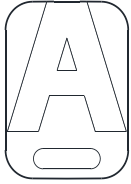

Booster



Indoor Antenna



Outdoor Antenna

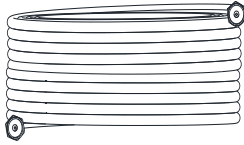

60 ft of 3D-FB Cable

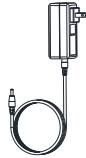

Power Supply



Mounting Parts of Outdoor Antenna

Preparation

You Will Need (tools not included)

Make sure the following materials are prepared and ready for your installation.



1 to 2 hours



1 Person (2 people to make antenna calibration easier)



- ❑ Ladder
- ❑ Drill (if routing cable through wall)
- ❑ 1” -3” diameter existing pole for mounting Outdoor Antenna (Pole Mount can be purchased separately if needed)
- ❑ Recommended: Power Strip with surge protection

NOTE: These instructions will walk you through a “soft” install process to find the optimal locations for the inside and outside antennas, then through the process of the permanent installation.

Step 1: Inside Antenna Placement

Place the **Inside Antenna** where you need the greatest signal boost and place **Booster** in your desired location.

NOTE: Do not connect booster to power until the system is fully installed.

Choose right position for the indoor antenna

- 1 feet away from any other metallic objects
- 3 feet away from any windows

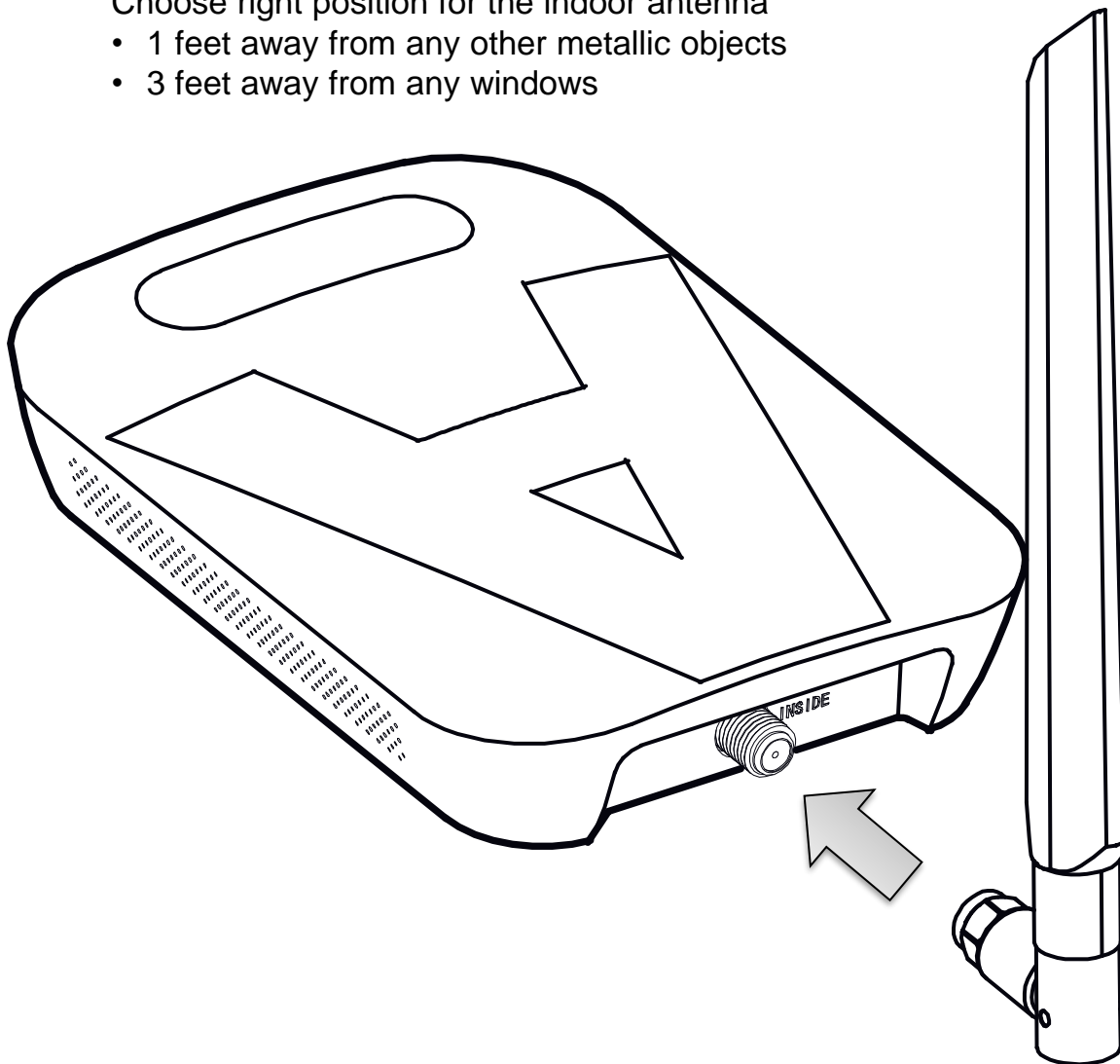



(STEP 1-A & B cont.)

Booster Placement

Mount the **booster**

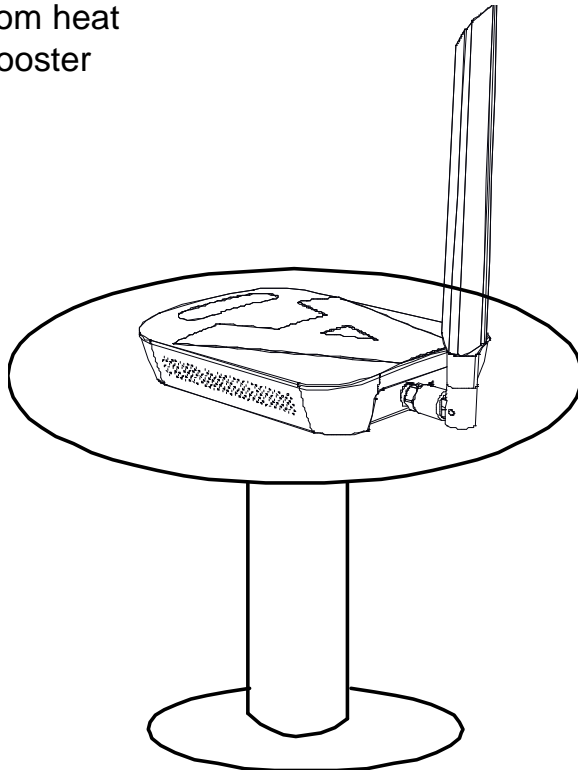
- Choose a ventilated and dry place
- Keep away from heat
- Don't cover booster



 Booster will about 30 degrees Fahrenheit higher than the ambient temperature, which is a normal phenomenon.

Step 2: Mount & Point Outside Antenna Toward Nearest Cell Tower

Pole mounting and wall mounting options are included. The pole mounting option is preferred because it will be easier to adjust to the direction of the cell tower.

Attach the **Mount** to the Outside Antenna and use the **Bracket Clamps** to attach the Antenna to a pole or exhaust pipe.

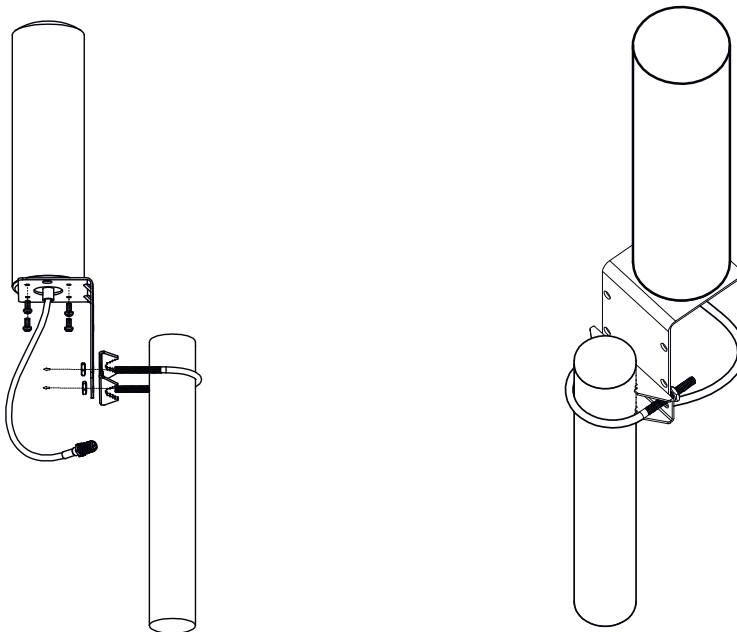

Make sure that the outside unit is mounted at least 3 feet away from any windows.

Outdoor antenna must be installed over the roof line.

NOTE: Mounting on existing roof exhaust pipe would be a good time-saver option. Watch out for power lines.

Point the **Outside Antenna** toward the nearest cell phone tower. To find the nearest tower, use an app such as 'Open Signal'. **This is the most critical step of the installation process because it will determine the overall performance of the booster system.**

The greater the separation between the Inside and Outside Antennas, the better performance you will get from the booster.

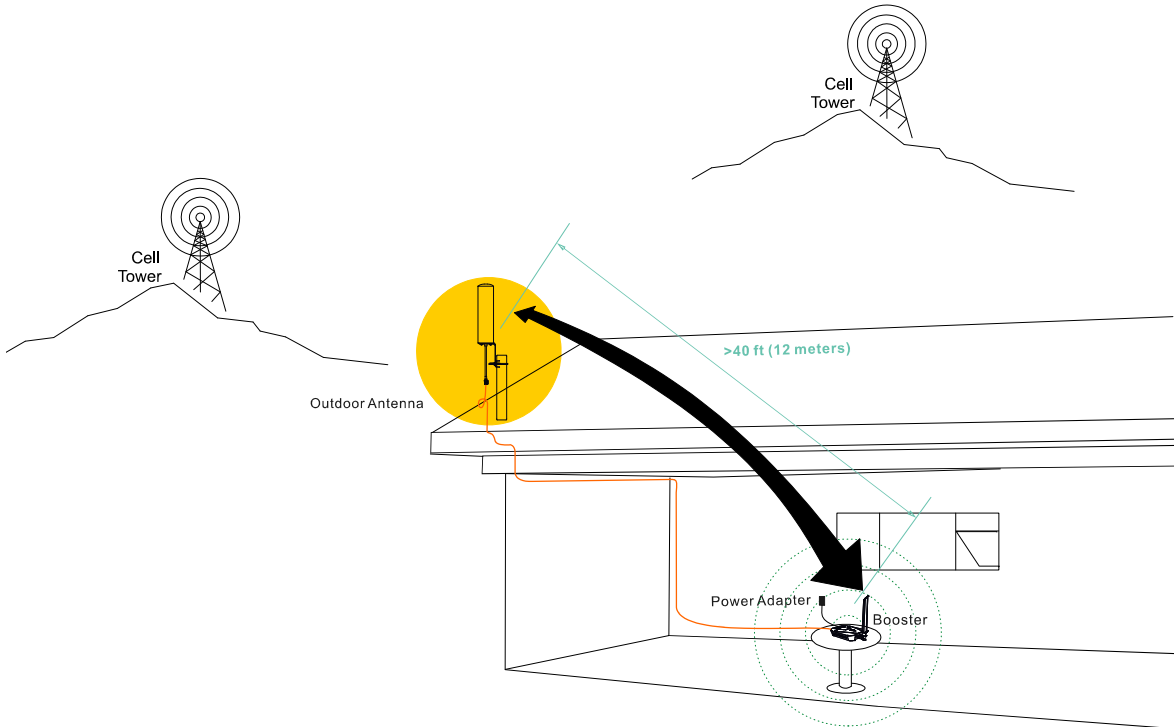

NOTE: The Outside Antenna must be at least **40 feet** (12 meters) **Straight line distance** **30 feet** (9 meters) **horizontal** or **20 feet** (6 meters) **vertical** from the Inside Antenna for best performance. Make sure the Inside Antenna and Outside Antennas are setup so they are **facing away** from each other.

Step 3: Route & Connect Outside Antenna To Booster

Connect the white **3D-FB Cable** to **Outside Antenna** and route cable into the home, secure the cable near the antenna. All connections should be **finger tightened** only.

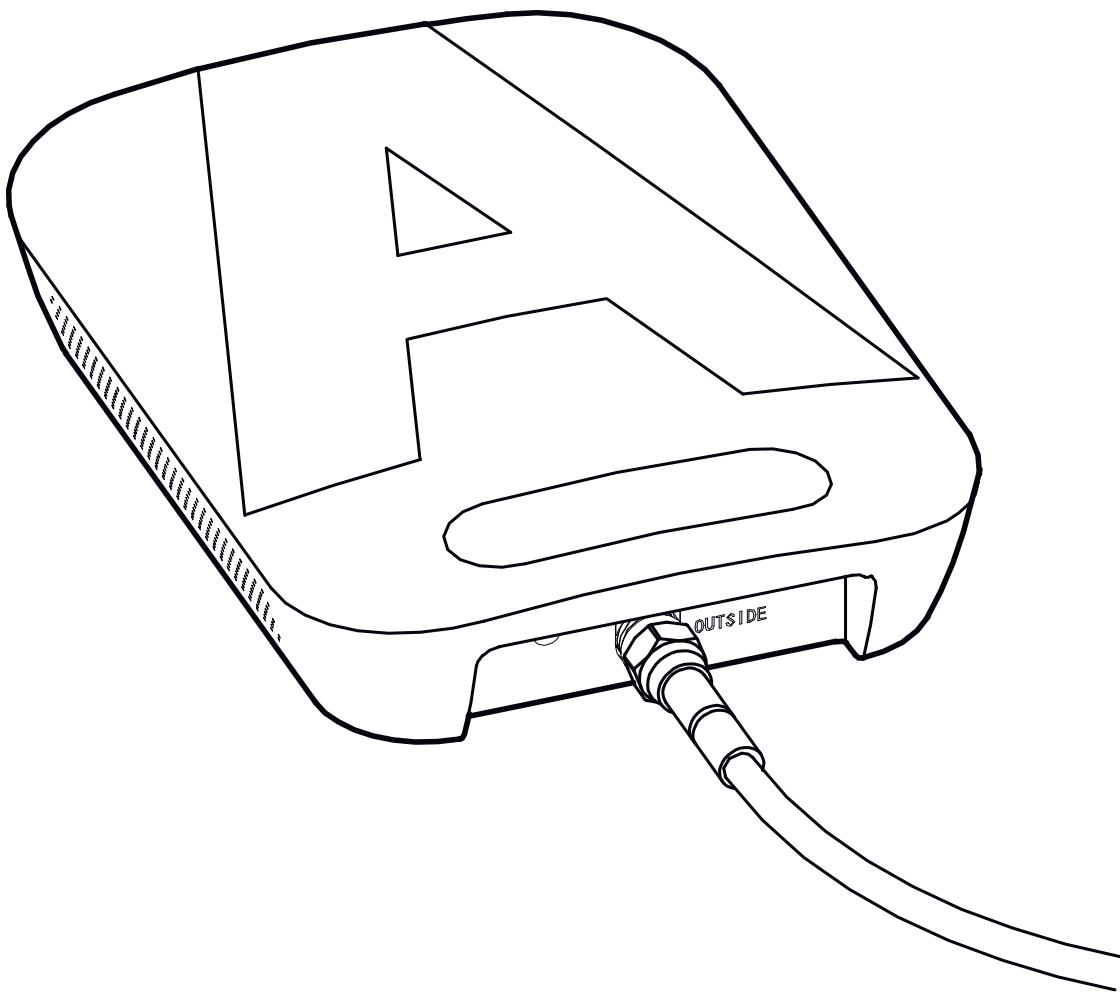

Route cable to the **Booster** and connect to the port labeled 'OUTSIDE'.

Step 3: Route & Connect Inside Antenna To Booster

Connect the **Inside Antenna** to the 'INSIDE' port on the **booster**.

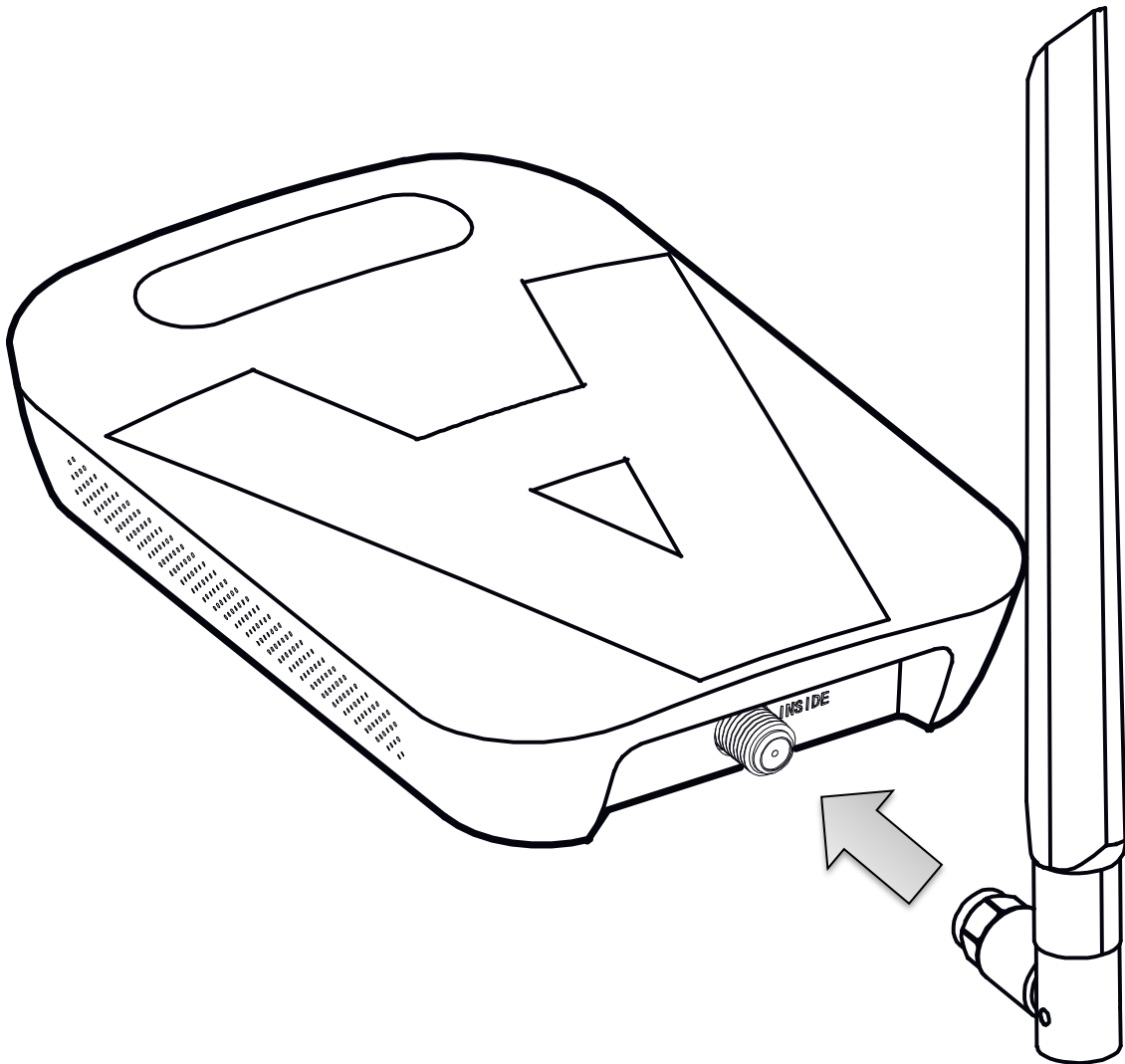

Step 4: Power Up The Booster & Optimize The System

Plug in the **Power Supply** and connect it to the nearest power outlet.

NOTE: We strongly recommend using a power strip with surge protection.

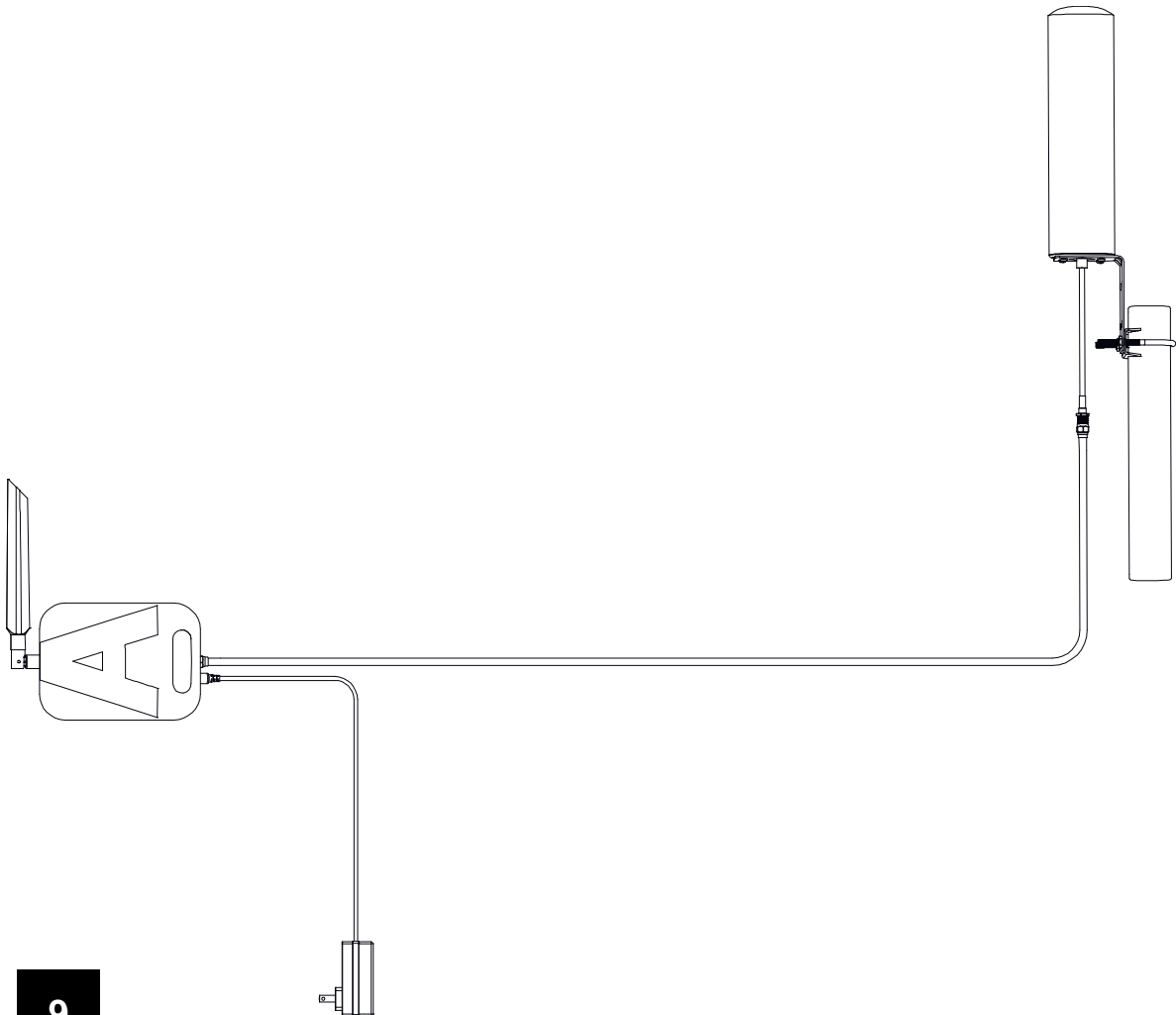

Measuring Booster Performance

How To Get Signal Strength As A Number

iPhone®

iOS 11 and later no longer displays the decibel (dBm) reading in 'Field Test Mode'. Tip: Using the dot signal strength indicator on your cell phone can assist you in finding the strongest signal direction as well as placing calls in different locations.

[iPhone: dial *3001#12345#* then press call](#)

Android™

Settings > About Phone > Status or Network > Signal Strength or Network Type and Strength (exact options/wording depends on phone model).

[Android: download third part APP-LTE Discovery](#)

iPhone is a registered trademark of Apple Inc. Android is a trademark of Google Inc.

(MEASURING BOOSTER PERFORMANCE cont.)

Signal Strength without Booster

Note here: _____

Signal Strength with Booster

Note here: _____

Compare Results

Having an accurate measurement of signal strength in decibels (dBm) is crucial when installing your system. Decibels accurately measure the signal strength you are receiving.

DID YOU KNOW a signal increase of just 3dB is 2 times the power and signal amplification!

Light Patterns

Panel Indicator

Correct Functioning:

- The band indicator lights on the front panel indicate the status of each band of the booster. Every time the power is turned on, all the indicators will turn green for about 1 second. This means that the booster has passed the self-test and is in good condition. When there is no problem with the system, all the indicators remain solid green during operation.

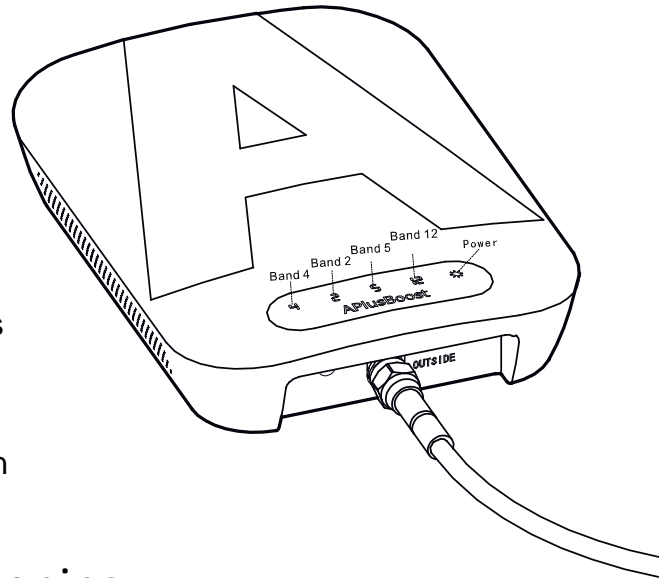

DC Power Indicator Correct Functioning:

- Power Light should be solid green after powered on.

Band Indicator Lights Blinking Red:

- Band has reduced gain. Which lights blinking indicate that the corresponding booster bands have reduced power due to a feedback loop condition called oscillation. This is a built in safety feature to prevent harmful interference with a nearby cell tower. If you are already experiencing the desired signal boost, then no further adjustments are necessary. If you are not experiencing the desired boost in coverage then refer to the Troubleshooting section.

Band Indicator Lights Solid Red:

- Band has shutoff. This is due to a feedback loop condition called oscillation. This is a built in safety feature that causes a band to shut off to prevent harmful interference with a nearby cell tower. Refer to Troubleshooting section.

DC Power Indicator Off:

- Please check your outlet, make sure it is normal.

Troubleshooting

IF YOU ARE HAPPY WITH THE COVERAGE, THESE LIGHT ISSUES DON'T HAVE TO BE RESOLVED. YOUR CARRIER'S BAND HAS NOT BEEN AFFECTED.

FIXING ANY BAND INDICATOR LIGHTS BLINKING ISSUES

Band Indicator Lights Blinking Red

1. Band Indicator Lights Blink 1 To 15 Times (1 cycle)

That means the gain lowered 1~15 dB. If your coverage is good and reception is good, you can ignore the blink.

2. Band Indicator Lights Blink All The Time

That means the gain lowered 15~25 dB. Check and install the whole system again.

FIXING ANY BAND INDICATOR LIGHTS SOLID ORANGE ISSUES

Band Indicator Lights Solid Orange

That means shut down. Check and install the whole system again.

FIXING DC POWER INDICATOR OFF ISSUES

Please verify your power supply has power; contact with us by email or call for replacement.



Troubleshooting

How does oscillation happened:

1. Indoor antenna receive leak signal from the outdoor antenna;
2. Booster amplify the signal and then transmit it to the outdoor antenna;
3. Outdoor antenna broadcast the signal in the air, some of the signal back to indoor antenna and become leak signal;
4. If the gain of the booster higher than the loss of the leak signal, the leak signal will become bigger and bigger, finally oscillation happened.

How to confirm that oscillation has occurred:

1. Panel light flash or solid red/orange after power on;
2. Screw off the indoor antenna from the booster;
3. Restart the power supply;
4. All indicator lights flash once time after power on show self-test finished;
5. The panel light doesn't flash or solid on. Such a situation means your system has oscillation problem.

How to solve the problem of oscillation:

Keep enough distance between indoor and outdoor antenna

Minimum Required Separation Distance Between Indoor and Outdoor Antennas:

Straight line distance over 40 feet(12 meters) or

30 feet (9 meters) horizontal distance

20 feet (6 meters) vertical distance (as far as possible).

Safety Guidelines

To uphold network protection standards and ensure compliance, all active cellular devices must maintain a separation distance of at least six feet between the inside unit antenna and outside unit antenna and at least four feet of separation distance from the inside unit.

Use of a non-APlusBoost product or accessory may result in damage to the equipment or components of the equipment.

The inside unit is designed for use in an indoor, temperature-controlled environment (less than 100 degrees Fahrenheit). It is not intended for use in attics or similar locations where temperatures may be in excess of that range.

RF Safety Warning: Any antenna used with this device must be located at least 8 inches from all persons.

This is a **CONSUMER** device.

BEFORE USE, you **MUST REGISTER THIS DEVICE** with your wireless provider and have your provider's consent. Most wireless providers consent to the use of signal boosters. Some providers may not consent to the use of this device on their network. If you are unsure, contact your provider.

In Canada, **BEFORE USE** you must meet all requirements set out in ISED CPC-2-1-05. You **MUST** operate this device with approved antennas and cables as specified by the manufacturer. Antennas **MUST** be installed at least 20 cm (8 inches) from (i.e., **MUST NOT** be installed within 20 cm of) any person.

You **MUST** cease operating this device immediately if requested by the FCC or licensed wireless service provider.

You **MUST** cease operating this device immediately if requested by the ISED or licensed wireless service provider.

WARNING. E911 location information may not be provided or may be inaccurate for calls served by using this device.

This device may be operated **ONLY** in a fixed location for in-building use.

FOR MORE INFORMATION ON REGISTERING YOUR SIGNAL BOOSTER WITH YOUR WIRELESS PROVIDER, PLEASE SEE BELOW:

Sprint: http://www.sprint.com/legal/fcc_boosters.html

T-Mobile/MetroPCS: <https://support.t-mobile.com/docs/DOC-9827>

Verizon Wireless: <http://www.verizonwireless.com/wcms/consumer/register-signal-booster.html>

AT&T: <https://securec45.securewebsession.com/attsignalbooster.com/>

U.S. Cellular: <http://www.uscellular.com/uscellular/support/fcc-booster-registration.jsp>

Specifications

Model Number	SF001			
FCC ID	2A34B-SFZN001			
Connectors	F-Female on the inside Antenna / F-Female on the Outside Antenna			
Noise figure	5 dB nominal			
Antenna Impedance	75 Ohms / 75 Ohms			
Weight	0.35Kg			
Frequency	698-716MHz,824-849MHz,1850-1915MHz,1710-1755MHz 728-745MHz,869-894MHz,1930-1995MHz,2110-2155MHz			
Power output for single cell phone (Uplink)dBm	700A-MHz Band12 62	800MHz Band5 65	1900MHz Band2 65	1700MHz Band4 65
Power output for single cell phone (Downlink)dBm	700A-MHz Band12 64	800MHz Band5 65	1900MHz Band2 68	2100MHz Band4 68
EIRP	1W Max			
Operating temperature	5°F to 140°F (-15°C~60 °C)			
Isolation	>110 dB			
Power Requirements	AC / DC 12V,1.5A, w/1.35X3.5mm Jack			

This device complies with Part 15 of FCC rules. Operation is subject to two conditions:

(1) This device may not cause harmful interference, and (2) this device must accept any interference received, including interference that may cause undesired operation.

Changes or modifications not expressly approved by APlusBoost could void the authority to operate this equipment.

CPC-2-1-05 — Zone Enhancers - Spectrum management and telecommunications

<http://www.ic.gc.ca/eic/site/smt-gst.nsf/eng/sf08942.html>

Warning:Unauthorized antennas/cables and/or coupling devices are prohibited by FCC rules. Please contact FCC for details: 1-888-CALL-FCC

NEED HELP ?

 www.aplusboost.com

Booster transmitting in 1710-1755 MHz should be install/operate in one of two ways:
(i) the antenna for the device must be installed to comply with the 10 meter above ground maximum antenna height limitation OR
(ii) the antenna for the device has a 10 meter above ground maximum antenna height limitation when the device is used with a handset that covers the 1710-1755 MHz band and that owners could be subject to potential FCC enforcement action for noncompliance.



3 YEAR WARRANTY

The Booster is covered under a three-year product warranty for failures or defects that result from craftsmanship and/or materials. Dated proof of purchase should be retained for use in warranty cases. Contact the retailer/reseller directly with any warranty issues, or alternatively contact the manufacturer in cases where the reseller is no longer available to handle warranty claims. In cases where the reseller is unavailable, the product may be returned to the manufacturer at the consumer's expense, with a dated proof of purchase and a return authorization letter which can be attained by contacting APlusBoost.

This warranty does not apply to any signal booster components determined by APlusBoost to have been subjected to misuse, abuse, neglect, tampering, or mishandling that result in damages to the physical or electronic properties of the product. Refurbished products that have been recertified to conform to product specifications may be used for product replacements.

DISCLAIMER: The information provided by APlusBoost is believed to be complete and accurate, to the best of our knowledge. However, no responsibility is assumed by APlusBoost for any business or personal losses arising from the use of the information herein contained, or for any infringements of patents or other rights of third parties that may result from its use.

Antenna Kitting Information

Component	Prod No. Description	Gain/Loss				Notes
		LTE-A	800MHz	1900MHz	1700MHz\2100MHz	
Outdoor Antenna	A-SF001	8dBi	8dBi	10dBi	10dBi\10dBi	Log Periodic Antenna (Default)
	A-SF002	3dBi	3dBi	5dBi	5dBi\5dBi	Omni Directional Antenna
Outdoor Cable	RG660Feet	4dB	4.3dB	6.5dB	6.5dB \7dB	60 feet
Outdoor Cable	3D-FB60Feet	4.5dB	5.4dB	8dB	8dB \9dB	60 feet (Default)
Outdoor Cable	3D-FB30Feet	2.1dB	2.5dB	3.6dB	3.6dB\ 4.1dB	30 Feet
Indoor Cable	3D-FB30Feet	2.1dB	2.5dB	3.6dB	3.6dB\ 4.1dB	30 Feet
Indoor Cable	RG630Feet	1.8dB	1.9dB	3.1dB	3.1dB \3.2dB	30 feet
Indoor Antenna	A-SF003	8dBi	8dBi	10dBi	10dBi\10dBi	Panel Antenna
	A-SF004	2dBi	2dBi	3dBi	3dBi\3dBi	Whip Antenna (Default)

*All equivalent antennas and cables are suitable for use with the xxx

Notes

NEED HELP ?





www.aplusboost.com



XXXXXXXXXX



APlusBoost.business@outlook.com