

DFS TEST REPORT

Applicant: Blackshark Technologies (Nanchang) Co., Ltd.

Address of Applicant: Room 815-1, 8th floor, Block A, Huajiang Building, No. 1
Tsinghua Science Park

Equipment Under Test (EUT)

Product Name: 5G Digital Mobile Phone

Model No.: SHARK KTUS-H0

Trade mark: BLACK SHARK

FCC ID: 2A2ZHKTUS-H0

Applicable standards: FCC CFR Title 47 Part 15 Subpart E Section 15.407

Date of sample receipt: 11 Mar., 2022

Date of Test: 12 Mar., to 16 May, 2022

Date of report issued: 17 May, 2022

Test Result: PASS*

*In the configuration tested, the EUT complied with the standards specified above.

Authorized Signature:



Bruce Zhang
Laboratory Manager

This report details the results of the testing carried out on one sample. The results contained in this test report do not relate to other samples of the same product and does not permit the use of the JYT product certification mark. The manufacturer should ensure that all products in series production are in conformity with the product sample detailed in this report.

This report may only be reproduced and distributed in full. If the product in this report is used in any configuration other than that detailed in the report, the manufacturer must ensure the new system complies with all relevant standards.

This document cannot be reproduced except in full, without prior written approval of the Company. Any unauthorized alteration, forgery or falsification of the content or appearance of this document is unlawful and offenders may be prosecuted to the fullest extent of the law. Unless otherwise stated the results shown in this test report refer only to the sample(s) tested and such sample(s) are retained for 90 days only.

2 Version

Version No.	Date	Description
00	17 May, 2022	Original

Tested by: Mike.ou **Date:** 17 May, 2022
Test Engineer

Reviewed by: Winner Zhang **Date:** 17 May, 2022
Project Engineer

3 Contents

Page

1	COVER PAGE.....	1
2	VERSION	2
3	CONTENTS	3
4	TEST SUMMARY.....	4
5	GENERAL INFORMATION.....	5
5.1	CLIENT INFORMATION	5
5.2	GENERAL DESCRIPTION OF E.U.T.	5
5.3	TEST ENVIRONMENT AND MODE.....	5
5.4	DESCRIPTION OF SUPPORT UNITS.....	5
5.5	RELATED SUBMITTAL(S) / GRANT (S)	5
5.6	ADDITIONS TO, DEVIATIONS, OR EXCLUSIONS FROM THE METHOD	5
5.7	LABORATORY FACILITY	5
5.8	LABORATORY LOCATION	6
5.9	TEST INSTRUMENTS LIST.....	6
6	DFS TECHNICAL REQUIREMENTS.....	7
6.1	DFS PARAMETERS	7
6.2	DFS TECHNICAL REQUIREMENTS	9
6.3	DFS THRESHOLD LEVEL	9
6.4	TEST SETUP BLOCK.....	9
6.5	EUT CONFIGURATION FOR DFS TEST.....	10
7	TEST RESULT	11
7.1	VERIFICATION OF RADAR TYPE AND LEVEL.....	11
7.2	CHANNEL MOVE TIME AND CHANNEL CLOSING TRANSMISSION TIME.....	12
8	TEST SETUP PHOTO	13

4 Test Summary

Test Items	Limit	Result
Channel Availability Check	> 60 seconds	N/A
UNII Detection Bandwidth	> 100% of the UNII 99% transmission power bandwidth	N/A
Statistical Performance Check	Radar type 1,2,3,4 \geq 60% Aggregate Radar type 1~4 and 5 \geq 80% Radar type 6 \geq 70%	N/A
Channel Move Time	< 10 seconds	Pass
Channel Closing Transmission Time	< 20ms + aggregate of 60ms over remaining 10 second period	Pass
Non-Occupancy Period	> 30 minutes	N/A
<p>Remark:</p> <ol style="list-style-type: none"> 1. Pass: means meet the requirements. 2. N/A: means not applicable. 3. The cable insertion loss used by "RF Output Power" and other conduction measurement items is 0.5dB (provided by the customer). 		
Test Method:	ANSI C63.4-2014 ANSI C63.10-2013 KDB 789033 D02 General UNII Test Procedures New Rules v02r01 KDB 905462 D02 UNII DFS Compliance Procedures New Rules v02 KDB 905462 D03 UNII Clients Without Radar Detection New Rules v01r02	

5 General Information

5.1 Client Information

Applicant:	Blackshark Technologies (Nanchang) Co., Ltd.
Address:	Room 815-1, 8th floor, Block A, Huajiang Building, No. 1 Tsinghua Science Park
Manufacturer:	Blackshark Technologies (Nanchang) Co., Ltd.
Address:	Room 815-1, 8th floor, Block A, Huajiang Building, No. 1 Tsinghua Science Park

5.2 General Description of E.U.T.

Product Name:	5G Digital Mobile Phone
Model No.:	SHARK KTUS-H0
Transmitter frequency range:	5150MHz~5250MHz, 5250MHz~5350MHz 5470MHz~5725MHz, 5725MHz~5825MHz
Modulation type:	OFDM
WLAN Function:	802.11a/802.11n/802.11ac/802.11ax
Bandwidth:	20MHz/40MHz/80MHz/160MHz
Antenna Type:	Internal Antenna
Antenna Gain:	ANT5: -0.8 dBi ANT6: -1.2 dBi
DFS Operation Type:	<input type="checkbox"/> Master Device <input type="checkbox"/> Slaver Device with Radar detection function <input checked="" type="checkbox"/> Slaver Device without Radar detection function
Power supply:	Rechargeable Li-ion polymer Battery DC7.78V, 2240mAh
Test Sample Condition:	The test samples were provided in good working order with no visible defects.

5.3 Test environment and mode

Data Load mode:	Keep the EUT in normal transmitting mode by WiFi
Temperature:	20 ~ 25 °C
Humidity:	60% ~ 65%
Atmospheric pressure:	1012 kPa

5.4 Description of Support Units

Manufacturer	Description	Model	Serial Number
LENOVO	Laptop	SL510	2847A65
ASUS	Router	GT-AX11000	LAICHR000121

5.5 Related Submittal(s) / Grant (s)

This is an original grant, no related submittals and grants.
--

5.6 Additions to, deviations, or exclusions from the method

No

5.7 Laboratory Facility

<p>The test facility is recognized, certified, or accredited by the following organizations:</p> <ul style="list-style-type: none"> ● FCC - Designation No.: CN1211 JianYan Testing Group Shenzhen Co., Ltd. has been accredited as a testing laboratory by

FCC(Federal Communications Commission). The test firm Registration No. is 727551.

● **ISED – CAB identifier.: CN0021**

The 3m Semi-anechoic chamber and 10m Semi-anechoic chamber of JianYan Testing Group Shenzhen Co., Ltd. has been Registered by Certification and Engineering Bureau of Industry Canada for radio equipment testing with Registration No.: 10106A-1.

● **CNAS - Registration No.: CNAS L15527**

JianYan Testing Group Shenzhen Co., Ltd. is accredited to ISO/IEC 17025:2017 General Requirements for the Competence of Testing and Calibration laboratories for the competence of testing. The Registration No. is CNAS L15527.

● **A2LA - Registration No.: 4346.01**

This laboratory is accredited in accordance with the recognized International Standard ISO/IEC 17025:2017 General requirements for the competence of testing and calibration laboratories. The test scope can be found as below link: <https://portal.a2la.org/scopepdf/4346-01.pdf>

5.8 Laboratory Location

JianYan Testing Group Shenzhen Co., Ltd.

Address: No.101, Building 8, Innovation Wisdom Port, No.155 Hongtian Road, Huangpu Community, Xinqiao Street, Bao'an District, Shenzhen, Guangdong, People's Republic of China.

Tel: +86-755-23118282, Fax: +86-755-23116366

Email: info-JYTee@lets.com, Website: <http://jyt.lets.com>

5.9 Test Instruments list

Conducted Method:					
Test Equipment	Manufacturer	Model No.	Manage No.	Cal. Date (mm-dd-yy)	Cal. Due date (mm-dd-yy)
Spectrum Analyzer	Keysight	N9010B	WXJ004-3	10-25-2021	10-24-2022
Vector Signal Generator	Keysight	N5182B	WXJ006-6	10-25-2021	10-24-2022
RF Control Unit	MWRFTTEST	MW100-RFCB	WXG006	N/A	
Test Software	MWRFTTEST	MTS 8310	Version: 2.0.0.0		
N7607B Signal Studio	KEYSIGHT	--	Version: 2.0.0.1		

6 DFS Technical Requirements

6.1 DFS Parameters

Table D.1: Applicability of DFS Requirements Prior to Use of a Channel			
Requirement	Operational Mode		
	Master	Client Without Radar Detection	Client With Radar Detection
Non-Occupancy period	Yes	Not required	Yes
DFS Detection Threshold	Yes	Not required	Yes
Channel Availability Check Time	Yes	Not required	Not required
U-NII Detection Bandwidth	Yes	Not required	Yes

Table D.2: Applicability of DFS requirements during normal operation		
Requirement	Operational Mode	
	Master	Client Without Radar Detection
DFS Detection Threshold	Yes	Not required
Channel Closing Transmission Time	Yes	Yes
Channel Move Time	Yes	Yes
U-NII Detection Bandwidth	Yes	Not required

Additional requirements for devices with multiple bandwidth modes	Operational Mode	
	Master Device or Client with Radar Detection	Client Without Radar Detection
U-NII Detection Bandwidth and Statistical Performance Check	All BW modes must be tested	Not required
Channel Move Time and Channel Closing Transmission Time	Test using widest BW mode available	Test using the widest BW mode available for the link
All other tests	Any single BW mode	Not required

Note: Frequencies selected for statistical performance check (Section 7.8.4) should include several frequencies within the radar detection bandwidth and frequencies near the edge of the radar detection bandwidth. For 802.11 devices it is suggested to select frequencies in each of the bonded 20 MHz channels and the channel center frequency.

Table D.3: DFS Detection Thresholds	
Maximum Transmit Power	Value (See Notes 1,2, and 3)
EIRP \geq 200 mW	-64 dBm
EIRP < 200 mW and power spectral density < 10 dBm/MHz	-62 dBm
EIRP < 200 mW that do not meet the power spectral density requirement	-64 dBm

Note 1: This is the level at the input of the receiver assuming a 0 dBi receive antenna.
 Note 2: Throughout these test procedures an additional 1 dB has been added to the amplitude of the test transmission waveforms to account for variations in measurement equipment. This will ensure that the test signal is at or above the detection threshold level to trigger a DFS response.
 Note 3: EIRP is based on the highest antenna gain. For MIMO devices refer to KDB Publication 662911 D01.

Table D.4: DFS requirement values	
Parameter	Value
Non-occupancy period	Minimum 30 minutes
Channel Availability Check Time	60 seconds
Channel Move Time	10 seconds (See Note 1)
Channel Closing Transmission Time	200 ms + an aggregate of 60ms over remaining 10 second period (See Notes 1 and 2)
U-NII Detection Bandwidth	Minimum 100% of the UNII 99% transmission power bandwidth (See Note 3)

Note 1: Channel Move Time and the Channel Closing Transmission Time should be performed with Radar Type 0. The measurement timing begins at the end of the Radar Type 0 burst.

Note 2: The Channel Closing Transmission Time is comprised of 200 milliseconds starting at the beginning of the Channel Move Time plus any additional intermittent control signals required to facilitate a Channel move (an aggregate of 60 milliseconds) during the remainder of the 10 second period. The aggregate duration of control signals will not count quiet periods in between transmissions.

Note 3: During the U-NII Detection Bandwidth detection test, radar type 0 should be used. For each frequency step, the minimum percentage of detection is 90 percent. Measurements are performed with no data traffic.

Table D.5: Short Pulse Radar Test Waveforms					
Radar Type	Pulse Width (µsec)	PRI (µsec)	Number of Pulses	Minimum Percentage of Successful Detection	Minimum Number of Trials
0	1	1428	18	See Note 1	See Note 1
1	1	Test A Test B	Roundup $\left\{ \begin{matrix} \frac{1}{360} \\ \frac{19 \cdot 10^6}{PRI_{\mu sec}} \end{matrix} \right\}$	60%	30
2	1-5	150-230	23-29	60%	30
3	6-10	200-500	16-18	60%	30
4	11-20	200-500	12-16	60%	30
Aggregate (Radar Types 1-4)				80%	120

Note 1: Short Pulse Radar Type 0 should be used for the detection bandwidth test, channel move time, and channel closing time tests.

Table D.6: Long Pulse Radar Test Waveform							
Radar Type	Pulse Width (µsec)	Chirp Width (MHz)	PRI (µsec)	Number of Pulses per Burst	Number of Bursts	Minimum Percentage of Successful Detection	Minimum Number of Trials
5	50-100	5-20	1000-2000	1-3	8-20	80%	30

Long Pulse Radar Test Signal Wave form 12 second transmission

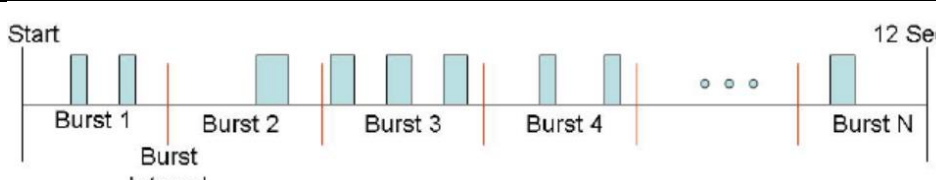

Table D.7: Frequency Hopping Radar Test Waveform							
Radar Type	Pulse Width (µsec)	PRI (µsec)	Pulses per Hop	Hopping Rate (kHz)	Hopping Sequence Length (msec)	Minimum Percentage of Successful Detection	Minimum Number of Trials
6	1	333	0	0.333	300	70%	30

6.2 DFS Technical Requirements

Requirement	DFS Operational mode		
	<input type="checkbox"/> Master	<input checked="" type="checkbox"/> Slave without Radar Detection	<input type="checkbox"/> Slave with Radar Detection
Channel Availability Check	√	Not Required	Not Required
UNII Detection Bandwidth	√	Not Required	√
Statistical Performance Check	√	Not Required	√
Channel Move Time	√	√	√
Channel Closing Transmission Time	√	√	√
Non-Occupancy Period	√	Not Required	√

6.3 DFS Threshold Level

DFS Threshold Level	
5250MHz ~ 5350MHz	-62 dBm @ antenna connector
5470MHz ~ 5725MHz	-62 dBm @ antenna connector
Note: The worst case level was selected to perform the test.	

6.4 Test Setup Block

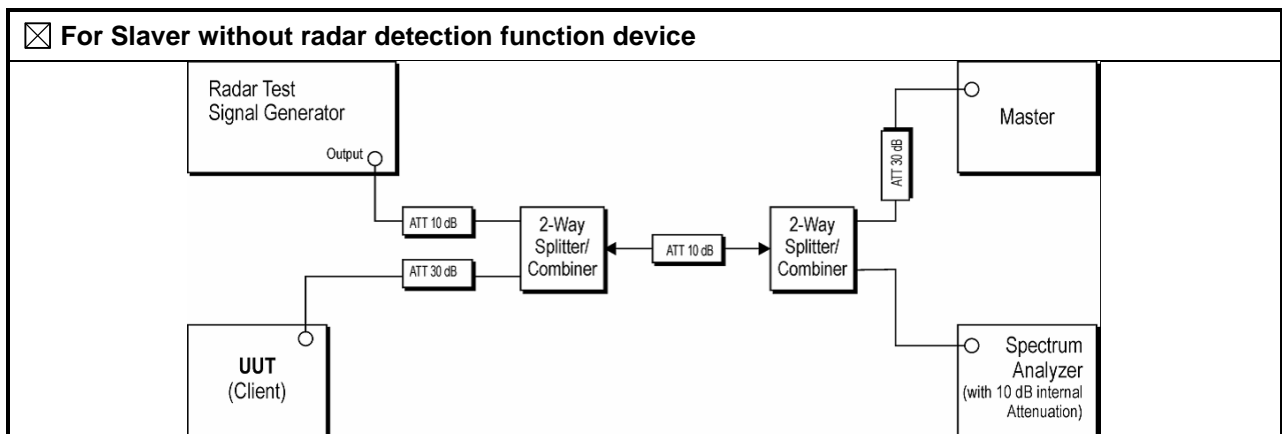
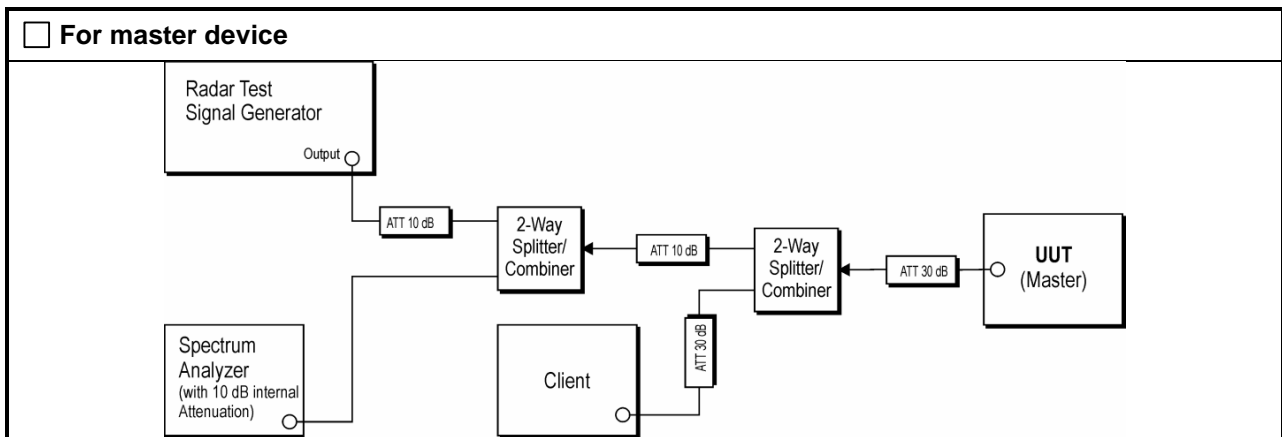

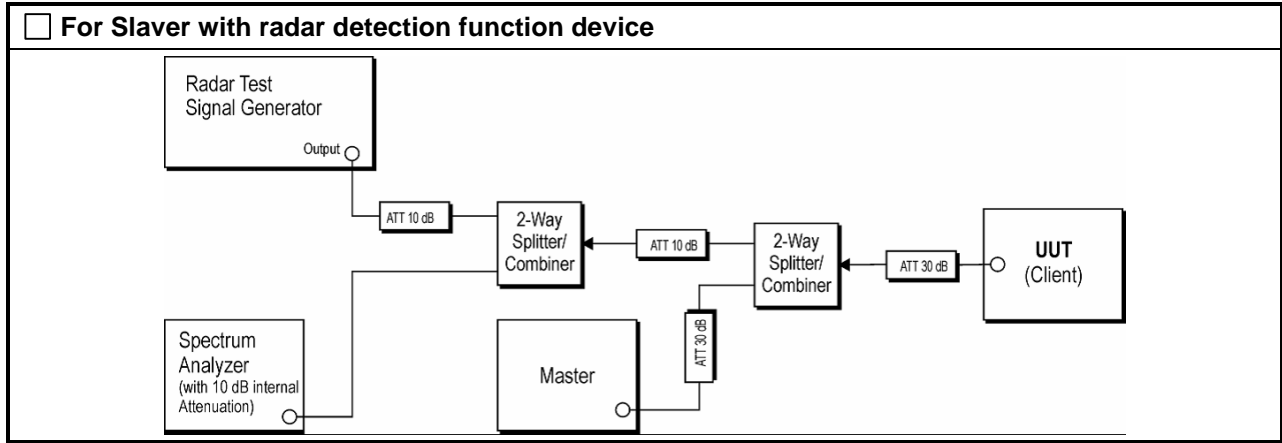

6.5 EUT Configuration for DFS Test

Test Items	Channel Frequency
Channel Move Time	5250MHz, 5570MHz
Channel Closing Transmission Time	5250MHz, 5570MHz

7 Test Result

7.1 Verification of Radar Type and Level

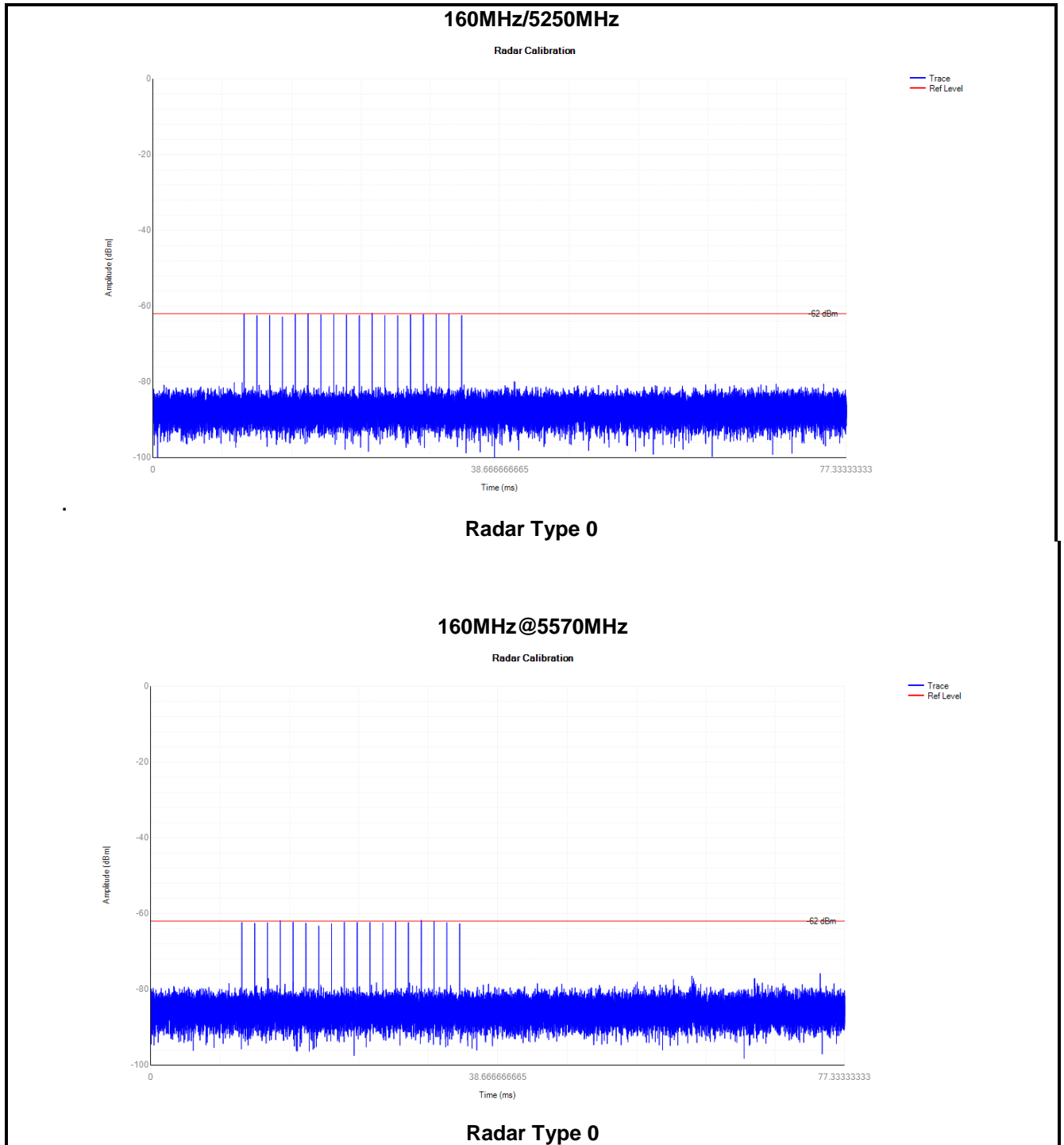

7.2 Channel Move Time and Channel Closing Transmission Time

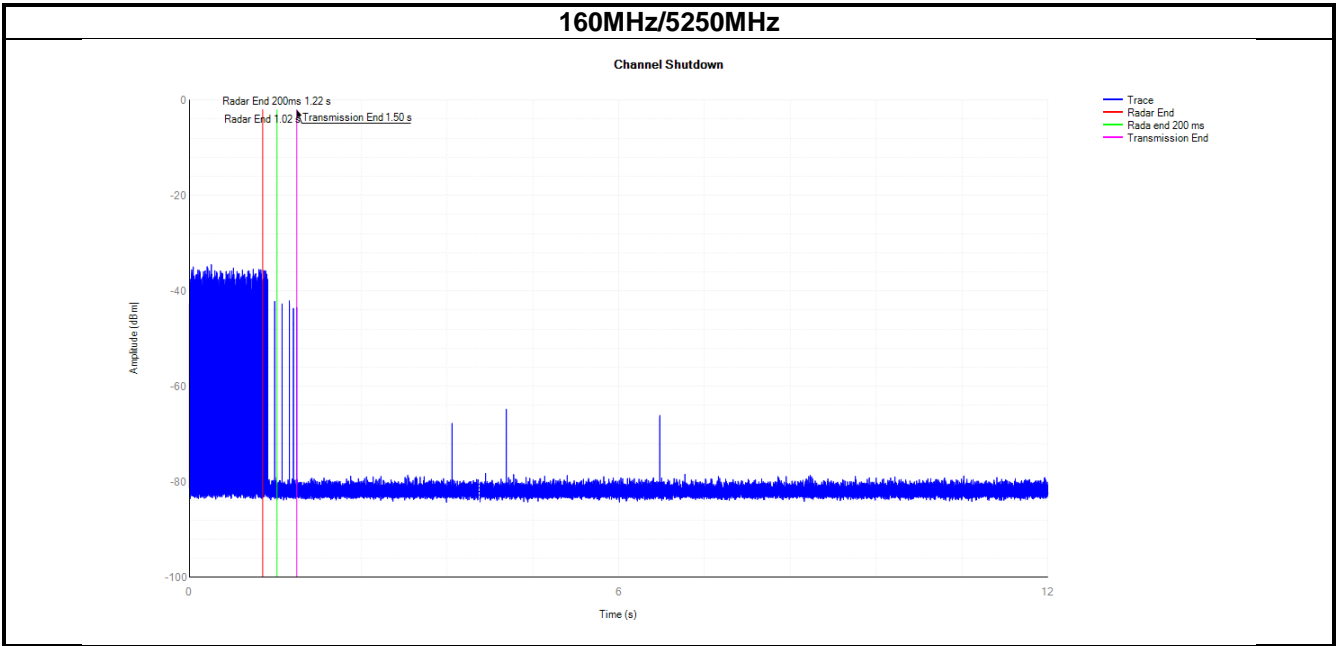

Test Items	Value	Limit
Channel Closing Transmission Time	38ms	260 ms
Channel Move Time	476 ms	10 s

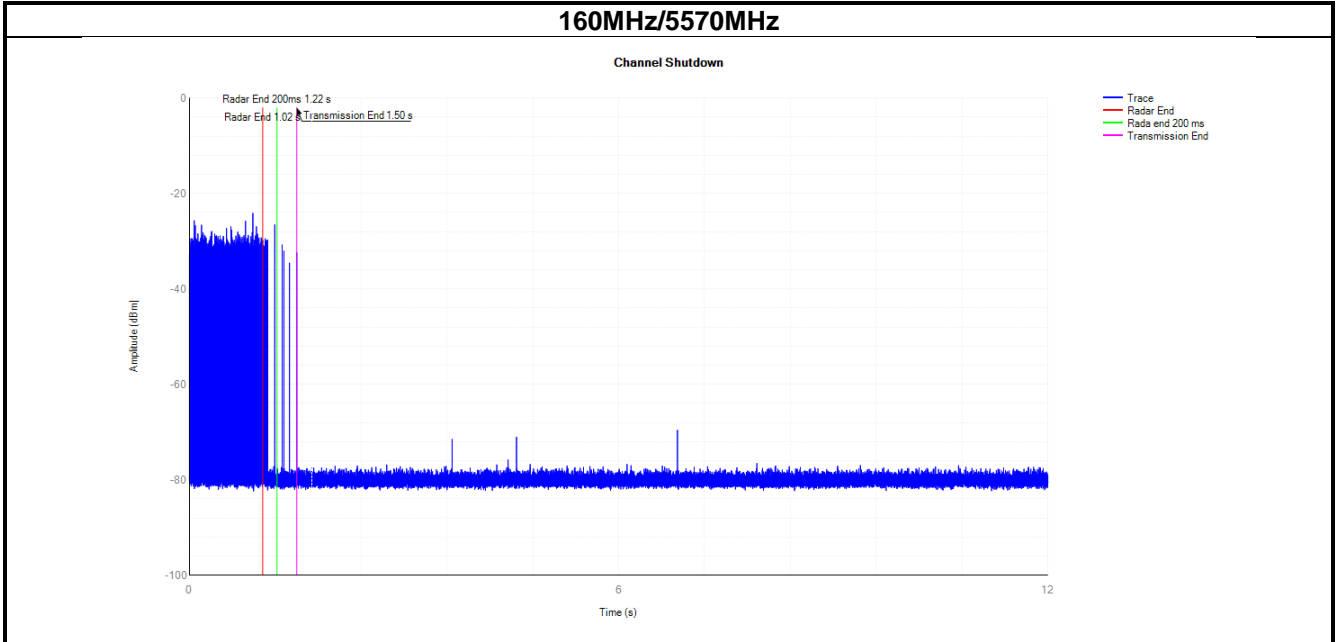

Test Items	Value	Limit
Channel Closing Transmission Time	35 ms	260 ms
Channel Move Time	478 ms	10 s

Test Result: Pass

8 Test Setup Photo



----- End of report -----