



Operation Manual

MEDRAD[®] Salient

Contrast Injection System



Contents

1.	Quick Start.....	1
2.	Introduction	3
2.1.	Important Safety Notice	3
2.2.	How To Read This Manual	3
2.3.	Certifications	3
2.4.	Intended Use.....	3
2.5.	Contraindications.....	3
2.6.	Trademarks.....	3
2.7.	Disclaimers.....	3
2.8.	Imaxeon Contact Information.....	5
2.8.1.	Manufacturer	5
2.8.2.	EC Representative.....	5
2.9.	SYRINGE - Warnings and Cautions	6
2.10.	INJECTOR - Warnings and Cautions.....	6
2.10.1.	[RCU models] Glomerular filtration rate (GFR) Calculator Warnings	9
3.	Getting Started.....	10
3.1.	Installation.....	10
3.2.	Injector Features	11
3.2.1.	Injector Head Description	12
3.3.	Symbols.....	13
3.3.1.	Symbols used in this manual	13
3.3.2.	Symbols used on labelling.....	13
3.3.3.	Handswitch and Footswitch	14
3.3.4.	Icons and Buttons used on the Injector Touch Screen Graphical Interface	15
3.3.5.	Injector Buttons	16
3.3.6.	Remote Control Symbols and Buttons	17
3.3.7.	Injector Visual Indicators	17
3.3.8.	Icons and Buttons used on the RCU Touch Screen Graphical Interface	18
4.	Clinical Information	22
4.1.	Cannula and Needle Selection.....	22
4.2.	Understanding pressure and flow, pressure limiting & adaptive flow	23
4.2.1.	Pressure Basics.....	23
4.2.2.	Summary	23
4.3.	Adaptive Flow, Pressure Limit and Over Pressure.....	24
4.3.1.	What to do in the event of adaptive flow reducing image quality	24
4.4.	Warming the Contrast: Heat Maintainer.....	25
5.	Operation Description.....	26

5.1.	Turning the System On for the First Time.....	26
5.2.	Syringe, Quick Fill Tube, Fill Spike, and Connector Tubes.....	27
5.2.1.	Description and Part Number	27
5.2.2.	Syringe MEDRAD® FluiDots	28
5.2.3.	Mounting the Syringe.....	29
5.2.4.	Select Syringe.....	29
5.3.	Filling a Syringe Using a Quick Fill Tube (QFT) or Fill Spike on the Injector.....	30
5.3.1.	Manual and Auto Filling Procedure	31
5.3.2.	[Optional] IV Holder.....	31
5.4.	[Optional] Off-line Filling.....	32
5.5.	Connector Tube Installation	32
5.6.	Dismounting a Syringe.....	33
5.7.	Performing an injection	34
5.7.1.	Routine Protocol Setup.....	34
5.7.2.	Arming	35
5.7.3.	Pressure Graph Display.....	35
5.7.4.	Starting the Injection	36
5.7.5.	Halting the Injection.....	36
5.7.6.	Common Injecting Alarms	37
5.7.7.	Post-Injection Review	38
5.8.	Programming.....	40
5.8.1.	Multi-phase protocol setup.....	40
5.8.2.	[Dual Only] Multi-phase contrast/saline protocol setup.....	40
5.8.3.	Phase Type Selection	41
5.8.4.	[Dual Only] Phase Type Selection	41
5.8.5.	Protocol Selection – Loading	42
5.8.6.	Protocol Selection – Saving	43
5.9.	Options Menu.....	44
5.9.1.	[Dual Only] Option Menu	45
5.9.2.	[RCU models] RCU Connection Setup.....	46
5.9.3.	Autofill Default Options.....	47
5.9.4.	Routine Protocol Default Options	47
5.10.	[RCU models] Operation Description with Remote Control Unit	48
5.10.1.	RCU Features–.....	48
5.10.2.	The Injector and the RCU	49
5.10.3.	Turning the System On / Off.....	49
5.10.4.	Injector Controller Application	51
5.10.5.	Filling State	53
5.10.6.	Routine Protocol.....	54

5.10.7.	Arming	54
5.10.8.	Check for Air.....	54
5.10.9.	Starting the Injection	55
5.10.10.	Injection in Progress.....	56
5.10.11.	Injection Control Buttons	57
5.10.12.	Injection Review	58
5.10.13.	Protocol Edit.....	59
5.10.14.	Edit Lock.....	60
5.10.15.	Parameter Value Edit.....	60
5.10.16.	Injecting remaining volume.....	60
5.10.17.	Edit Phase Type.....	61
5.10.18.	Open Protocol.....	62
5.10.19.	Protocol Save	62
5.10.20.	Common Injecting Alarms / Warnings.....	63
5.10.21.	RCU Manager	64
5.10.22.	RCU Setup	65
5.10.23.	History Viewer	67
5.10.24.	Protocol Manager	68
5.10.25.	eGFR (glomerular filtration rate) Calculator	68
5.11.	[Optional] DC200 Scanner Interface	70
5.11.1.	Overview	70
5.11.2.	DC200 Scanner Interface Setup	71
5.11.3.	Inject or Scan Delay	73
5.12.	[Optional] Protocol Assistance Tool (PAT).....	74
6.	Cleaning and Maintenance	76
6.1.	General Cleaning Procedures	76
6.1.1.	[RCU models] Cleaning the RCU	76
6.2.	Battery Maintenance.....	77
6.2.1.	Injector Batteries	77
6.2.2.	Remote Control Batteries	77
6.3.	Recommended Regular Check Procedure	78
6.3.1.	Monthly	78
6.3.2.	Annual Check.....	78
6.3.3.	Operator Checkout Procedure	79
6.4.	Disposing of the Injector	80
7.	Trouble-shooting	82
7.1.	Fault Finding Guide.....	82
7.1.1.	[RCU Models] Trouble-Shooting.....	83
7.2.	Error Messages	83

8.	Specifications	84
8.1.	Dimensions	84
8.2.	Mechanical	85
8.2.1.	[RCU Tablet] Mechanical	85
8.2.2.	[DC200] Mechanical	85
8.3.	Functional.....	85
8.4.	Controls	86
8.5.	Environmental	86
8.5.1.	[RCU Tablet] Environmental	86
8.5.2.	[DC200] Environmental	86
8.6.	Electrical.....	87
8.6.1.	[RCU Tablet] Electrical.....	87
8.7.	Connectors.....	88
8.8.	IEC 60601-1 Classifications	88
8.9.	Ground Continuity	88
8.10.	RoHS Statement.....	88
8.11.	IEC60601-1-2:2014 (4 th Ed) Compliance	89
8.11.1.	Electromagnetic Emissions	89
8.11.2.	Electromagnetic Immunity	89
8.11.3.	Recommended separation distances from portable and mobile RF communications equipment and the injector	91
8.12.	Models	92
8.13.	Accessories	92
8.14.	Manufacturer's Software License Information	93
8.15.	FCC Statement.....	93
9.	Index.....	94



1. Quick Start



§3 Getting Started

- Unpacking and installation
- System features
- Symbols and buttons



§4 Clinical Information

- Selecting cannulas and needles
- Understanding pressure and flow rates
- Adaptive flow

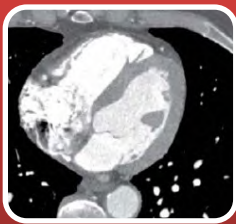

§5 Operation Description

- Filling
- Performing an injection
- Programming injection protocols



§6 Cleaning and Maintenance

- Cleaning
- Battery maintenance
- Regular checks



§7 Troubleshooting

- Error messages
- Injection failed

2. Introduction

Thank you for purchasing the MEDRAD® Salient Contrast Injector. Read this manual and follow the safety precautions closely so you will be able to use the injector and all of its features properly and safely. For the latest support information, visit our website: <http://www.imaxeon.com/>

Record the model number in the table below, together with the serial number of your system and your IMAXEON representative's telephone number.

DC009S (Single)	<input type="checkbox"/>		
DC009D (Dual)	<input type="checkbox"/>		
DC009SW (Single with Wireless RCU)	<input type="checkbox"/>		
DC009DW (Dual with Wireless RCU)	<input type="checkbox"/>		
<i>Model No</i>		<i>Serial No:</i>	<i>IMAXEON Service Representative Tel No:</i>

2.1. Important Safety Notice

The information in this manual is intended for medical personnel with adequate training and experience in X-ray imaging studies. Any attempt to operate or repair a medical device such as the injector without adequate training may result in personal injury, property damage or patient injury.

2.2. How To Read This Manual

READ this manual thoroughly before operating the injector and keep the manual available in the area where the injector will be used. This manual contains important information about the safe operation of the injector. Imaxeon urges the operators of the injector to read this manual carefully, become familiar with the injector functions it describes, and follow its recommended procedures.

The injector is offered in Single and Dual syringe versions. General operations common to both are described, and where the feature is specific to the Dual model, this is noted by [Dual Only].

2.3. Certifications

This injector is equipped to operate at 100 – 230 V~, 50/60 Hz, and is designed to comply with EN 60601-1 Ed 3.1 (safety) and EN 60601-1-2 Ed 4.0 (EMC/Emissions) standards.

Imaxeon Pty Ltd is EN ISO 13485:2016 certified.

2.4. Intended Use

The injector is intended to be used specifically for the purposes of venous injections of contrast agents and common flushing solutions [Dual Only] into adult and pediatric patients during x-ray imaging procedures. DO NOT attempt to use the injector for any other purpose.

2.5. Contraindications

This device is not to be used for drug infusion, chemotherapy, or any other use for which the device is not indicated.

2.6. Trademarks

Bayer, the Bayer Cross, Imaxeon, MEDRAD FluiDots, MEDRAD Salient, MEDRAD, Salient and FluiDots are trademarks owned by and/or registered to Bayer in the U.S. and/or other countries.

2.7. Disclaimers

This manual describes the use, operation and preventive maintenance needs of the MEDRAD® Salient Contrast Injector, herein referred to as “the injector”. Qualified and trained personnel should only use the injector. Use by unqualified and untrained personnel could result in patient or personal injury and property damage.

Imaxeon reserves the right to modify the specifications and features described herein, or discontinue manufacture of the product described at any time without prior notice or obligation. Please contact your authorised Imaxeon representative for the most current information.

Imaxeon disclaims liability for any modifications or interfaces with other equipment, which are not in conformity with the specifications and information contained within this manual. Such unauthorised action could jeopardize injector operation, safety, or reliability.

Accessory equipment connected to the injector through the interface connections must also be certified according to the requirements of EN 60601-1. Furthermore, the combined configuration of the injector with attached accessory equipment must comply with system standard EN 60601-1-1. To obtain on-site consulting or consulting references, contact Imaxeon Service, or your local service representative.

Imaxeon will make available on request any circuit diagrams, component parts lists, or other information, which will assist appropriately qualified technical personnel to repair the injector to a level deemed by Imaxeon to be field repairable. Contact Imaxeon Service, or your local service representative for further information.

2.8. Imaxeon Contact Information

2.8.1. Manufacturer



Imaxeon Pty. Ltd.
Unit 1, 38-46 South St,
Rydalmere, NSW, 2116
Australia
T: +61 2 8845 4999
F: +61 2 8845 4936
www.imaxeon.com
info@imaxeon.com



2.8.2. EC Representative



Bayer Medical Care B.V.
Avenue Céramique 27
6221 KV Maastricht
The Netherlands

2.9. SYRINGE - Warnings and Cautions



WARNING: A biological hazard may occur if syringes are reused.

Do not reuse the used syringe and fill tube with another patient. Properly dispose of the disposable in accordance with your facility's contaminated blood product disposable protocols.



WARNINGS

- ◆ **Correctly load the syringe.** Improper loading may cause an under volume delivery, air embolization or personal injury.
- ◆ **Filled syringes, which are stored, can promote bacterial growth.** Imaxeon syringes are intended to be filled, and then used immediately. Discard all filled syringes, in particular when removed from the injector for some period of time.
- ◆ **Minimize the length of the fluid path from the syringe to the patient. The connection of additional infusion systems/accessories to the central fluid path from the injector to the patient increases resistance to flow.** This could cause under flow rates, under volumes, or stall conditions which could possibly cause the procedure to be repeated.
- ◆ **Use extreme care when selecting flow rates** to avoid the unintentional programming of an inappropriate high rate injection. Always check settings before arming and injecting; **high flow rate injections may cause patient injury.**
- ◆ **Air embolization can cause patient injury or death; do not connect a patient to the injector until all trapped air has been cleared from the syringe, connector tubing and catheter.** Operator vigilance and care, coupled with a set procedure is essential to the avoidance of air embolism.
- ◆ **Patient infection may result from the use of non-sterile components, do not remove plunger to fill the syringe.** Maintain sterility of all disposable components.



CAUTIONS

- ◆ **The syringe may be damaged if hit with tools while attempting to eliminate air.** Only use the palm of hand to gently hit the syringe or pressure jacket to dislodge air bubbles.
- ◆ **Ensure pressure settings are lower than catheter and connector ratings.** Should an occlusion occur, disposable components with a lower pressure rating may be subjected to pressure beyond their capability, resulting in failure.
- ◆ **The syringe heat maintainer incorporates a failure indicator light; if indicator light is lit while on the syringe, remove the heat maintainer.** This indicates that the syringe heat maintainer is faulty and the built-in safety circuitry has disabled the heating mechanism.
- ◆ **If the syringe plunger material fails, remove it from the injector immediately.** The syringe is considered an applied part according to the IEC 60601-1 standard. This means it is in electrical contact with the patient via the fluid in the tubing. Any failure of the syringe plunger material may result in the fluid making electrical contact with the injector system.

2.10. INJECTOR - Warnings and Cautions



WARNINGS

- ◆ **Patient injury could occur if the on-screen manual fill controls are used when the patient is connected.** This could cause injury to the patient by delivery of contrast or blood extraction and may require the procedure to be repeated.
- ◆ **A possible explosion risk exists if the injector is used in the presence of flammable anaesthetics with air or oxygen or nitrous oxide.**
- ◆ **Regular maintenance should be performed.** To ensure that the injector stays properly calibrated and that all primary and backup systems are functioning properly, **yearly safety checking is recommended.** Contact your local Imaxeon Service Representative for further information.
- ◆ **Electromagnetic interference.** The injector must be installed in a suitable EMC environment according to the following:
 - ◆ Portable and mobile RF communications equipment can affect Medical Electrical Equipment.
 - ◆ To maintain compliance with EN IEC 60601-1-2 EMC compatibility requirements, do not substitute cables or connectors not recommended by the manufacturer as emissions or decreased immunity to interference may result causing erratic operation.
- ◆ **Plug the injector directly into properly grounded ac power outlet.** Do not use an extension power cord or adapter. Since the injector power cord supplies a safety ground to the injector during charging, using an extension cord will compromise the ground quality and the injector could become unsafe.
- ◆ **US/Canada Installations only.** Grounding reliability can only be achieved when this equipment is connected to an equivalent receptacle marked "Hospital Only" or "Hospital Grade".
- ◆ **Protective earth conductor.** Should the integrity of the external protective conductor in the installation or its arrangement be in doubt, the injector must be operated from the internal power source.
- ◆ **Connection to other equipment.** Injectors bearing the CE mark and having accessory equipment connected to the interface connectors must be certified according to the IEC 60601-1 standard. Furthermore, all configurations of injectors with attached accessory equipment must comply with system standard EN IEC 60601-1-1. Anyone who connects additional equipment to the signal input or output part configures a medical system and is therefore responsible that the system complies with requirements of the system standard EN 60601-1-1. To obtain on-site consulting or consulting references, contact local Imaxeon Service Representative.
- ◆ **A biological hazard may result if fluids, in particular blood or bodily fluids, to come into contact with the injector.** Fluid ingress could also adversely affect the function of the injection. Clean the injector immediately.
- ◆ **Accessible parts.** The operator should not contact the heat maintainer connector and the patient at the same time.
- ◆ **Use only the specified Imaxeon heat maintainer (DC022) with the MEDRAD® Salient injector.** Do not connect any other device to the injector heat maintainer connector.
- ◆ **Cease use of faulty components** – if a component appears to be faulty, e.g. RCU screen or heat maintainer, cease use until further investigation can be carried out.
- ◆ Changes or modifications not expressly approved by the party responsible for compliance could void the user's authority to operate the equipment.



CAUTIONS

- ◆ **Removal of covers may allow access to dangerous voltages.** There are no user-serviceable parts in the injector. Contact your local Imaxeon Service Representative for correct maintenance procedures, do not remove any covers or disassemble the injector in any way. Inspect the injector periodically for loose or frayed cables, loose covers, and signs of cracks, dents or loose hardware. Refer all injector servicing to authorised Imaxeon service representatives.
- ◆ **Shock hazard when cleaning.** In order to avoid shock and prevent damage to the injector, always disconnect the injector from line power before cleaning. Ensure that the injector is completely dry before reconnecting to line power.

- ◆ **Line voltage hazard.** To avoid dangerous voltages, do not remove the IEC connector (base cable) while line power is applied to the injector. Always disconnect the injector from line power before removing the IEC power connector.
- ◆ **Do not position the injector pedestal by pulling on the injector head, display or cabling.** Possible injury can occur if the injector head or stand falls on the patient or technician. Move the injector by grasping the handle and pulling or pushing the pedestal into place.
- ◆ **Pinch hazard.** Do not grasp any pivot points. Position the injector head by grasping the head alone.
- ◆ **Operator injury may result if excessive weight is applied to the device.** Do not place heavy objects or lean on the arm, injector head, or handles.
- ◆ **Operator injury may result from bottles falling from tray.** Do not place bottles on top of tray. Ensure that the bottles are placed in the recesses provided.
- ◆ **Operator injury may result during the transport of the injector.** Care should be used when transporting the injector. Ensure that the arm is properly secured in the locked position.
- ◆ **Operator or patient injury may result from inadvertent movement of the arm or injector head.** Periodically examine the articulating arm for signs of swaying and drooping. If any of these signs are evident, do not use the injector. Contact your local Imaxeon Service Representative for assistance.
- ◆ **For correct operation, use only accessories and options provided by Imaxeon, which are designed specifically for the injector.** Other accessories or options may cause equipment damage.
- ◆ **Improper or careless cleaning methods may result in equipment damage.** When cleaning any outside surface of the injector, avoid allowing any water or cleaning solutions to leak inside system components.
- ◆ **Stall conditions can occur when a low flow rate is selected in conjunction with a low-pressure limit.** Check the fluid path for a blockage. If no blockage exists in the fluid path, adjustments may be made to the flow rate or pressure limit according to physician's orders.
- ◆ **Electrical damage could occur due to condensation** if the injector is brought indoors from extreme outside temperatures and immediately used. Allow the injector to stabilize at room temperature before use.
- ◆ **Connect to correct line voltage and frequency.** Before applying line power, check the voltage and frequency range marked on the serial number tag on the base of the injector. The injector may be damaged when line power is outside the stated voltage range. Verify that the injector has the proper cord set for the plug style.
- ◆ **Provide sufficient clearance around the injector.** This may cause the injector to overheat and shut down. Installation clearance should be a minimum of 10cm.



- ◆ **This device contains materials that are potentially hazardous to the environment.** In accordance with the DIRECTIVE 2002/96/EC OF THE EUROPEAN PARLIAMENT AND OF THE COUNCIL on waste electrical and electronic equipment (WEEE), the injector system and accessories should not be disposed as unsorted municipal waste. Contact your Imaxeon Service Representative for disposal details.
- ◆ **Remove power when disconnecting or reconnecting head cable.** Disconnecting the head cable from the injector pedestal when line power is applied may cause equipment damage.
- ◆ **Battery replacement.** The injector batteries should be replaced only by suitably qualified service technicians. Replacement should not be attempted by users or their (untrained) service personnel. See Section 6.2 for more details. The battery in the remote control can be changed by users. See Section 6.2.2.
- ◆ **Battery pack disposal.** The injector contains lead acid batteries housed in a custom pack. Please dispose of this pack within environmental pollution guidelines depending on your local regulations.
- ◆ **BATTERY STORAGE** If the remote control will not be used for an extended period of time (more than two weeks), the battery should be removed from the remote control.

- ◆ **Injector may disarm or fail to operate when exposed to high magnetic fields.** Do not use radio transmitters, cellular phones or devices generating electrostatic discharge in the vicinity of the injector.
- ◆ **The syringe heat maintainer may be hot when in operation.** Avoid holding the heat maintainer when in operation.
- ◆ **The base cover may be damaged by impact.** This may also damage the components in the base. Avoid stepping on the base cover.
- ◆ **Moving the injector may cause risk of catheter pull-out during injection.** When injecting, lock the wheel castors, and prevent the injector head from moving. When moving the injector again, ensure the castors are unlocked, to avoid the injector tipping over.



- ◆ **Trapping hazard.** Be wary of retracting the piston of the injector head with syringes removed. Fingers can be trapped by the mechanism causing minor injuries.
- ◆ **Damage to the optional heat maintainer (DC022) can occur if it is connected to any device other than the injector heat maintainer connector.**
- ◆ **Pushing the injector at the top of the head bracket may cause the injector to tip.** Move the injector by holding and pushing by the injector handle only
- ◆ **[Wi-Fi Enabled models] Safe distance from medical equipment.** The injector has an output wireless power rating of less than 0.01W. Consult the documentation of your X-ray scanner for the recommended separation distance for equipment of this power rating. Imaxeon recommends maintaining at least 0.5m between the injector and scanner electronics.
- ◆ **[Wi-Fi Enabled models] Keep the RCU unit including the power supply away from liquids.** The RCU is not designed to have liquids splashed on it or to be immersed.
- ◆ **[Wi-Fi Enabled models] Keep the RCU plugged into mains power at all times.** The tablet does have a backup battery for emergency situations but this should only be used for short periods of time. The RCU is intended to be used on mains power during operation.

2.10.1. [RCU models] Glomerular filtration rate (GFR) Calculator Warnings

- ◆ **Calculation of the risk factor for contrast media dose using the RCU eGFR calculator are estimates, and should be used by trained personnel only.** The calculator assesses the risk based on patient parameters entered by the operator and the isotope dilution mass spectrometry (IDMS)-traceable Modification of Diet in Renal Disease (MDRD) Study equation. The clinician should use the result, in combination with clinical experience to decide on the dose and separately program the volume into the injection protocol.
- ◆ **No injection parameters are modified by the injector automatically as a result of the GFR calculation.** The injection protocols should be adjusted by the operator.
- ◆ **The eGFR calculation is not recommended for paediatric patients.** The MDRD is only recommended for adult patients.

3. Getting Started

3.1. Installation

<p>1.</p>  <p>Diagram showing three components: A (a large black cylindrical part), B (a smaller black cylindrical part), and C (a metal L-shaped tool).</p>	<p>2.</p>  <p>Diagram showing the device's arm being attached to a base. Part A is being inserted into the base. An orange arrow points to the base, and another orange arrow points to the device's arm.</p>
<p>3.</p>  <p>Diagram showing the device's arm being inserted into the base. Part B is being inserted into the base, and part C is being used to tighten the base. A warning symbol is present. Orange arrows indicate the direction of insertion and tightening.</p>	<p>4.</p>  <p>Diagram showing the device's power cord being plugged into the base. An orange arrow points to the power cord.</p>
<p>5.</p>  <p>Close-up photograph of the power cord connection. The label 'CB' is visible. A red arrow points to the power cord. A diagram below shows the power cord being inserted into the base.</p>	<p>6.</p>  <p>Diagram showing the device on a mobile cart. A clock icon indicates a 4-hour charging time. A red arrow points to the power cord.</p>

3.2. Injector Features



3.2.1. Injector Head Description

The injector is a modern, microprocessor-controlled powered injector system.

Syringes are loaded into the injector with a simple bayonet locking system.

Filling the syringes is accomplished with both manual and automatic (preset volume) powered options on the injector itself.

After loading the syringes, the user interacts with the injector primarily via a colour touch screen interface.

The injector is powered on by pressing the “Standby Button” shown in the figure above. The unit can always power on, whether connected to mains supply or by using the internal batteries. Whenever the mains supply is connected and switched on with the switch on the base unit, the batteries will be charged.

The initial screen shown here will be displayed every time you power on the injector.







[Dual Only] The Dual injector allows two syringes to be fitted simultaneously, one for saline and one for contrast.

This allows saline flush procedures to improve contrast delivery efficiency, image quality and reduced artefacts.

















3.3. Symbols

3.3.1. Symbols used in this manual

	Warnings advise of circumstances that could result in injury or death to the patient or operator. Read and understand all warnings before operating the injector. Consult accompanying documents/text. <i>The symbol is located throughout this manual and on the injector labelling as required.</i>
	Warning, biological hazard
	Electrical Shock Hazard
	Pinch Hazard
	Cautions advise of circumstances that could result in damage to the injector. Read and understand all cautions before operating the injector.

3.3.2. Symbols used on labelling

	Do not dispose in municipal waste, in accordance with the DIRECTIVE 2002/96/EC OF THE EUROPEAN PARLIAMENT AND OF THE COUNCIL on waste electrical and electronic equipment (WEEE).
	Identifies the terminal which provides a connection between the injector and the equipotential busbar of the electrical installation. <i>The symbol is located on the base power panel</i>
	Identifies switch position for disconnection from line power. <i>The symbol is located on the power switch on the base power panel.</i>
	Identifies switch position for connection to line power. <i>The symbol is located on the power switch on the base power panel.</i>
	Identifies type BF medical equipment complying with EN 60601-1 standards. <i>The symbol is located on the base power panel.</i>
CLASS 1	Indicates the system is Class 1 medical equipment as defined by EN 60601-1 standards. <i>The symbol is located on the base power panel.</i>
CB	Identifies circuit breaker. <i>The symbol is located on the base power panel.</i>
	Identifies protective earth. <i>The symbol is located within the base unit.</i>

	<p>Identifies location for connection of the START switch - either a hand-switch or footswitch can be connected.</p> <p><i>The symbol is located on the base power panel</i></p>
	<p>Name and address of the manufacturer</p>
	<p>Manufacturing Date (YYYY-MM)</p>
	<p>Consult instructions for use.</p>
	<p>Circuit breaker is out or tripped and requires resetting</p>
	<p>Circuit breaker is in-circuit; unit is ready for use on battery or mains</p>
	<p>Fuse</p>
	<p>Standby switch: on the injector head, this switch turns the injector head on and off.</p> <p>Mains power applied; batteries charging: on the injector base, the LED marked with this symbol indicates that mains power is on and the batteries are charging (regardless of whether the injector head is on or off).</p> <p><i>If the LED is lit then mains is available and the battery is charging.</i></p>

3.3.3. Handswitch and Footswitch











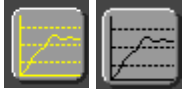

Pressing the green button on the hand-switch or pressing the footswitch will start an injection if the injector is currently armed. They have no effect if the injector is not armed.

When the injector is injecting, pressing the green button or pressing the footswitch again stops the current injection immediately. They have no effect if the injector is not injecting.



3.3.4. Icons and Buttons used on the Injector Touch Screen Graphical Interface

Note: The touchscreen does not have multi-touch functionality. To avoid incorrect input, please touch one control at a time

	Identifies that line power is connected to the injector
	Identifies that system is running on batteries. Animates during charging, and shows empty/full status
	Back or Previous - navigation. Also halts paused or held injections and cancels editing operations.
	Forward or Next - navigation
	Retract Button: Used to disengage plunger and release syringe
	Engage Button: Used to move the piston forward to engage the syringe
	Auto-Fill Button
	Load saved protocol
	Routine Protocol: The routine protocol is a simple injection protocol which delivers one phase.
	Save As – used in Protocols
	Press to arm injector in preparation for injection. If the injector is in Hold mode, this button aborts the injection
	Hold Phase
	Indicates Pause phase of the injection
	Manual Fill Mode
	<p>Syringe indicator.</p> <p>Green indicates contrast</p> <p>[Dual Only] Blue indicates saline</p> <p>The location of the black symbol indicates the current position of the plunger, with the remaining volume indicated. If the syringe is not engaged, the black symbol turns grey, and indicates the last known position of the plunger.</p>

	Manual Fill Controls for manual fill/purge of contrast or [Dual Only] saline. Larger gradations indicate higher fill/purge speed, and the arrows indicate the direction of the piston
	(On-screen) Start Injection button
	(On-screen) Stop Injection button
	Display Pressure Graph (toggle button). During injection, the screen can be switched between showing the syringe indicators to a real-time pressure graph of the current injection phase. When the pressure graph is active, the button is shown in yellow.
	Pressure indicator
	Duration/Elapsed Time indicator
	Average flow
	Injection entered adaptive flow
	Space – used as a space-bar when typing with the alphanumeric keypad
	Go to the Options menu
	Finger jam warning. While moving, if any obstruction is encountered by the piston, the piston will halt and the warning displayed.
	Press  to move forward, remove obstruction, then toggle  to continue retraction

3.3.5. Injector Buttons

	Identifies the ARM button - located on the injector power head When indicated by the software, the user must press this button to ready the injector for the programmed injection.
	Identifies the INJECTOR on/off button - located on the power head When the LED is unlit, the unit may be powered on by pressing the button and the injector will start up either from battery or mains. The LED displays red during self testing and then green when the injector is powered up.

3.3.6. Remote Control Symbols and Buttons

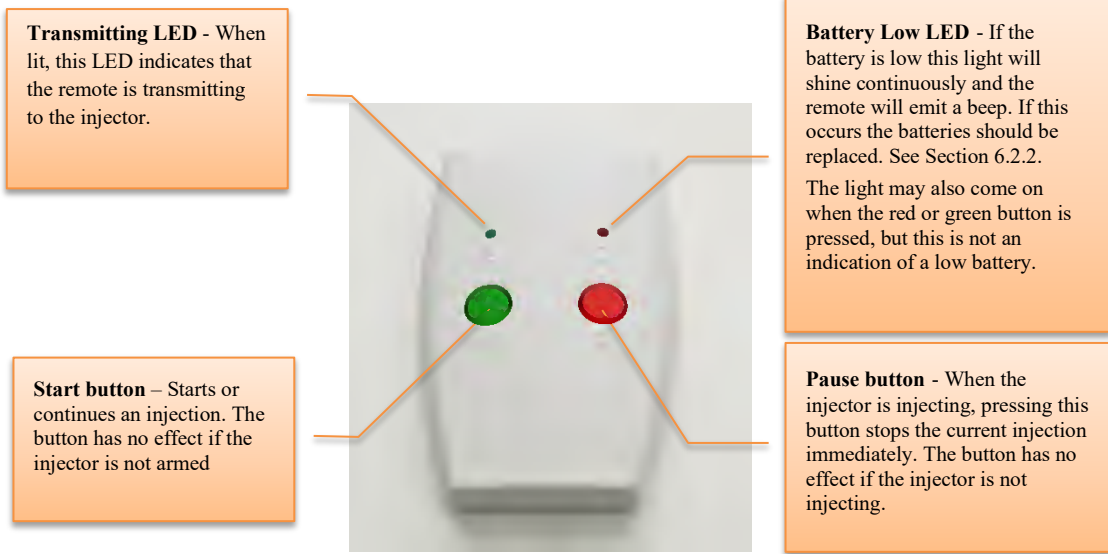









3.3.7. Injector Visual Indicators





Event	LEDs at rear of injector head	LCD Display
<i>Injector Error Condition¹</i>	Flash Red	Red Status Bar
<i>Warning</i>	Flash Orange	Orange Status Bar
<i>ARMED State</i>	Flash Green	Flashing ARM symbol
<i>INJECTING State</i>	Rotate Green	Flashing Syringe
<i>INJECT COMPLETE State</i>	Stop rotating (orange if adaptive flow occurred, green otherwise)	Nothing
<i>Touch screen Button press</i>	Nothing	Nothing
<i>Motor movement</i>	Rotate green	Animated Syringe
<i>Adaptive Flow (Pressure Limiting)</i>	Rotate orange	Orange Status Bar



¹ Notes: There are no alarm presets in the injector.

All error conditions indicate a fault with the injector and the injection has stopped. Warnings and other indicators indicate continued but changed operation of the injector.

3.3.8. Icons and Buttons used on the RCU Touch Screen Graphical Interface

Injector Controller Action Menu	
	RCU Manager – return to RCU manager screen
	GFR Calculator: Uses the Modification of Diet in Renal Disease (MDRD) Study equation to estimate an appropriate contrast dose based on patient parameters.
	Saved Protocols: View and select saved injection protocols stored on the RCU.
	Save As Protocol: Save the current protocol under another protocol name. This button is disabled when grey.
	ARM injector
	Start inject
	Resume inject
	Pause inject
	Abort inject
	Skip Phase
	Aborting inject
	Injection Review Table Mode
	Injection Review Plot Mode
	Injection completed
	Export Injection History Data
	Injection terminated with over pressure
	Injection aborted from user
	Injection terminated with timeout
	Injection terminated with an alarm event
	PACS (Picture Archiving and Communications System) link. Transmits injection data to the PACS system.

Power Status	
	Battery Low
	Battery half
	Battery full
	Mains power

Filling/Injection Status	
	<p><Animation> Injector is in filling status</p>
	<p><Animation> Injection in progress</p>

RCU Manager	
	Injector Controller: This is the application used to control the paired injector.
	History Viewer: Stored injections performed while the RCU was interfaced with the injector is stored in the RCU memory and can be reviewed from this application
	Protocol Manager: Protocols can be saved or restored from a removable USB memory drive.
	Media Player: The RCU stores a number of training videos that can be used to familiarise new users with the features of the injection system.
	Setup
	Service Options menu [locked, accessible by authorised service personnel only]
	RCU Information – information on RCU software version.
	Standby button
	RCU Reset button

4. Clinical Information

4.1. Cannula and Needle Selection

Cannulas or I.V. catheters are the preferred choice for injecting contrast agents with powered injectors. The following chart shows the maximum flow rate that is possible with typical gauge cannulas. However, operating the injector at or close to maximum flow rate may lead to adapted (reduced) flow, which may result in sub-optimum images.

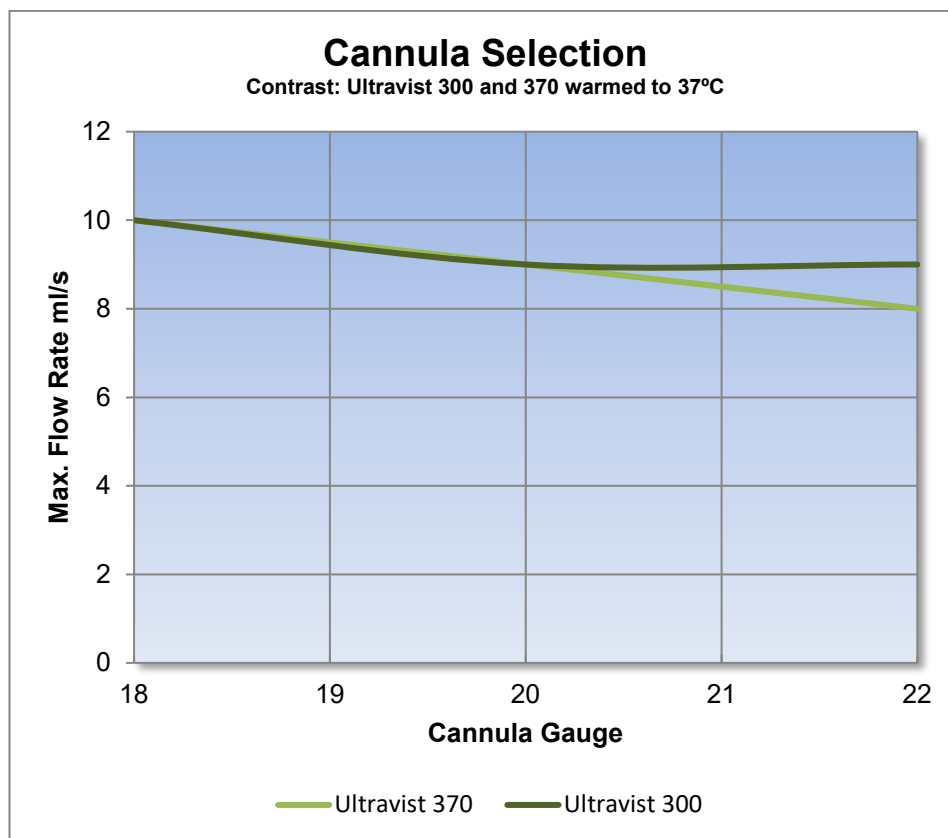

4.2. Understanding pressure and flow, pressure limiting & adaptive flow

4.2.1. Pressure Basics

In all hydraulic systems, pressure is required to cause fluid to flow through the conduit. The pressure in the reservoir (syringe) must exceed the resistance of the conduit (tubing and catheter) and fluid. The conduit offers resistance by its diameter and length. The fluid offers resistance by its thickness, or viscosity.

All hydraulic systems require pressure to cause the fluid to flow through the conduit. But here is an often misunderstood basic fact of pressure: **pressure will be dissipated in the conduit**. Pressure serves only to propel the fluid through the conduit. Because there is no opposition (resistance) to the fluid at the open end of the conduit, the fluid will be at zero pressure at the open end. The pressure is highest at the connection between the reservoir and the conduit (syringe and connector tubing). At the open end of the conduit (catheter distal end within the patient), the fluid will be at zero pressure (or rather the patient's systemic pressure), because there is no opposition to the fluid at the open end. The illustration below shows how pressure varies in a conduit. To simplify the following discussion, neglect the patient's systemic pressure and assume that there is zero pressure at the open end of the conduit. Pressure is greatest in the fluid reservoir and at the connection of the conduit to the reservoir. Halfway down the conduit, the pressure will be half of the reservoir pressure. And at the end of the conduit, pressure will be zero.

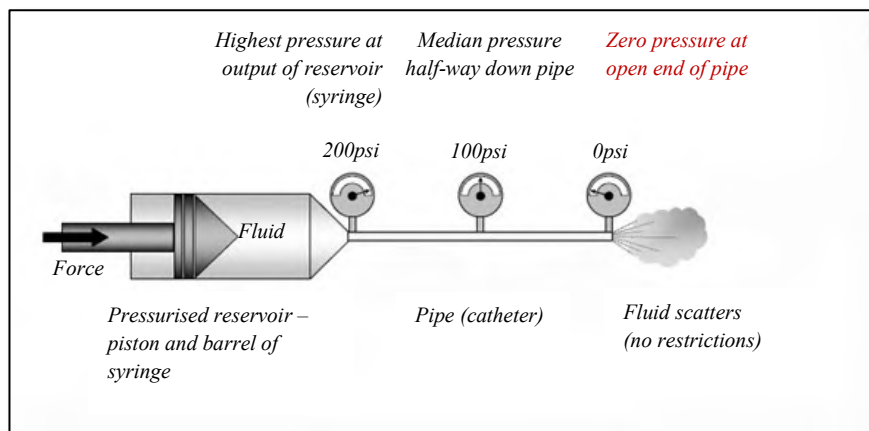

4.2.2. Summary

1. The reservoir (syringe) pressure must exceed resistance in the conduit (tubing and catheter) if fluid is to flow through the conduit
2. Higher pressure is required the smaller the diameter of the conduit (tubing, catheter), the longer the conduit, and the more viscous the media.
3. The diameter of the conduit is the factor with the highest impact on pressure (and achievable flow rates)
4. Pressure will dissipated (decrease) in the conduit so that the pressure at the open end will be zero as long as there is no obstruction at the outflow end.
5. If the pressure limit is set lower than the pressure required to propel media at the desired flow rate, the flow rate through the catheter will be reduced.
6. If the pressure limit is set higher than the pressure required to propel media at the desired flow rate, the flow rate through the catheter will not be affected. This pressure limit will protect the catheter only if the catheter becomes blocked.

4.3. Adaptive Flow, Pressure Limit and Over Pressure

At normal injection pressures, the injector will maintain the programmed flow rate. The x-ray image should display good contrast and opacity.

However, if the fluid path encounters a blockage, or if the connected disposables restrict the flow of contrast, the syringe pressure will rise. In order to ensure patient safety and protect the disposable system, the flow rate will be automatically reduced by the injector in order to reduce excessive pressure on the fluid line. Reduction of flow rate in this condition is known as *adaptive flow*.

When adaptive flow occurs:

- ◆ Lower opacification may result, and the images may give an appearance of being “washed out”.
- ◆ The injection duration will increase.
- ◆ The injector beep will lengthen to indicate flow rate reduction is occurring and the LEDs at the back of the injector head flash orange

Adaptive flow will start as the pressure approaches the pressure limit setting. This pressure limit is a user-programmable value from 100 to 300 psi in 1 psi increments. If the gradual reduction of flow does not sufficiently reduce the pressure, a motor stall will result, halting the injection.

If the syringe pressure exceeds the pressure limit by 20%, the injection will halt immediately. This is known as *overpressure*.²

The injector is designed to be a regulated fluid delivery device, which monitors pressure for safety reasons.

4.3.1. What to do in the event of adaptive flow reducing image quality



WARNING

Always check the pressure and flow limitations of any disposables to be used with this injector. The system will remind you of the need to check before an injection can proceed. You are urged to visually check the packaging of disposables for a pressure and flow rate limit and adjust the injector limits to be below the limits marked on the packaging.

If adaptive flow occurs, and the image quality is reduced, check the fluid path for a blockage. If no blockage exists in the fluid path, the operator may decrease the flow rate setting or increase the pressure limit setting and re-arm the system. If the flow rate or pressure limit is to be changed, re-check the physician’s orders.

² In the event of a sudden blockage during an injection, a very rapid pressure rise may occur. The injector will go into overpressure and stop without entering the flow reduction process. In this situation, the pressure can exceed the Pressure Limit for very short periods of time, insufficient to damage disposable sets.

4.4. Warming the Contrast: Heat Maintainer

For improved patient comfort and lower viscosity, contrast manufacturers recommend warming contrast to body temperature before use (i.e. 37°C). It is also recommended that the contrast be warmed for at least 2 hours prior to use, because heat permeates contrast very slowly.

Imaxeon provides a syringe heat maintainer part number DC022, which can be used to maintain the heat of the fluid in the syringe. The warmer is powered from a port located on the underside of the injector head unit.



[Dual Only] The Dual injector includes two connectors for saline and contrast heat maintainers.



 **WARNING**

Use only the specified Imaxeon heat maintainer (DC022) with the Salient injector. Do not connect any other device to the injector heat maintainer connector.

 **WARNING**

The syringe heat maintainer incorporates a red failure indicator light; if indicator light is lit while on the syringe, remove the heat maintainer. This indicates that the syringe heat maintainer is faulty and the built-in safety circuitry has disabled the heating mechanism.



5. Operation Description

5.1. Turning the System On for the First Time

Plug in a power cable to the IEC socket and connect the cable to your mains supply.

Ensure that the power switch in the pedestal base is in the On position, and that the circuit breaker is in-circuit (pushed in).



When the mains supply is connected and turned on at the switch, LED marked  will light indicating the presence of mains power and the fact that the batteries are being charged.

Leave the system plugged in for at least four hours before attempting to use with battery power alone.

The system is generally operated from battery power. If the batteries are low, or have been removed for servicing, the injector can operate from line power directly.

Once charged, press the on/off button.



The Start screen will be displayed. Press the  button.

If the injector is started for the first time since factory delivery, or has had a service performance maintenance procedure since the last power, a clinical efficacy screen will be displayed for information purposes.



5.2. Syringe, Quick Fill Tube, Fill Spike, and Connector Tubes

5.2.1. Description and Part Number

The syringe is available in a 190 ml size, suitable for use with contrast and saline flushing agents.

 <p>ZY6320: 190 ml Syringe with quick fill tube (QFT) (tray packaging)</p>	 <p>ZY6321: 190 ml Syringe with spike (tray packaging)</p>
 <p>ZY6322: 190 ml Syringe with spike (pouch packaging)</p>	 <p>ZY6323: 190 ml Syringe with quick fill tube (QFT) (pouch packaging)</p>
 <p>ZY6324: 190 ml Syringe with spike, 150 cm connecting tube (pouch packaging)</p>	 <p>ZY6325: 190 ml Syringe with quick fill tube (QFT), 150 cm connecting tube (pouch packaging)</p>



5.2.2. Syringe MEDRAD® FluiDots

A fluid-filled syringe is easily checked by noting the shape of the MEDRAD® FluiDots on the side of the syringe. When **viewed through fluid**, MEDRAD® FluiDots indicators will appear larger and rounded. Viewed through an empty syringe, the indicators will appear small and narrow.

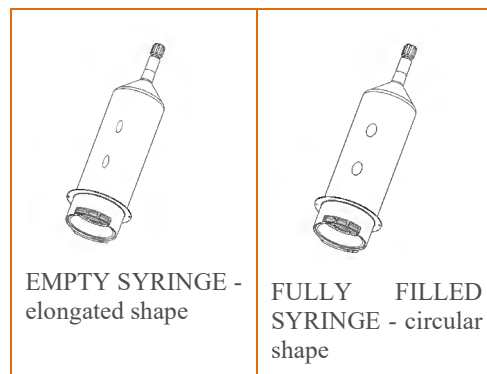

5.2.3. Mounting the Syringe

Remove the syringe from its packaging. Mount the syringe into the injector bayonet fitting as shown and twist a quarter of a turn to lock it into place.

If the injector is on, the syringe will automatically be detected. See Section 5.2.4.



5.2.4. Select Syringe

New, unfilled syringe

The injector will detect this and automatically purge the syringe of air.





Syringe filled on offline loader (Section 5.4)

The injector will detect this and be ready to proceed with the injection.

To manually select a syringe:

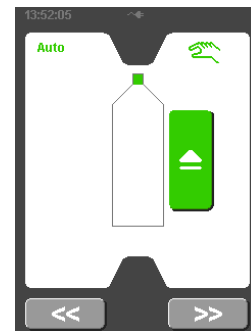
Press  on the touchscreen to tell the injector that a new contrast-filled syringe has been installed.



[Dual Only] Press  to tell the injector a saline-filled syringe has been installed.

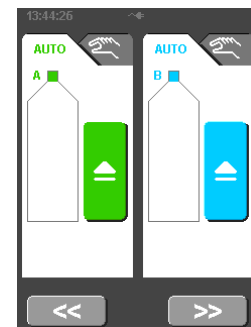

5.3. Filling a Syringe Using a Quick Fill Tube (QFT) or Fill Spike on the Injector

Syringes may be filled to a preset volume using the injector AutoFill functionality or to any arbitrary volume using the Manual fill controls. See Section 5.5 for details on connecting the tubing.

If the syringe is removed after filing, the piston will auto-retract.

[Using ZY6320, ZY6322, ZY6325] The syringe can be filled using a quick fill tube. Insert the tube onto the syringe and fill from the saline/contrast bottle.



[Using ZY6321, ZY6323, ZY6324] Alternatively, the syringe may be filled using a fill spike and a saline/contrast bottle or bag. Do not over-tighten the spike when mounting it on the syringe.

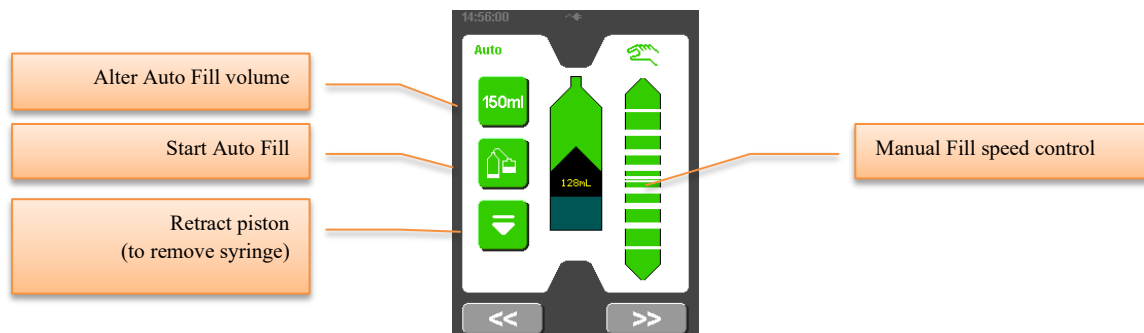



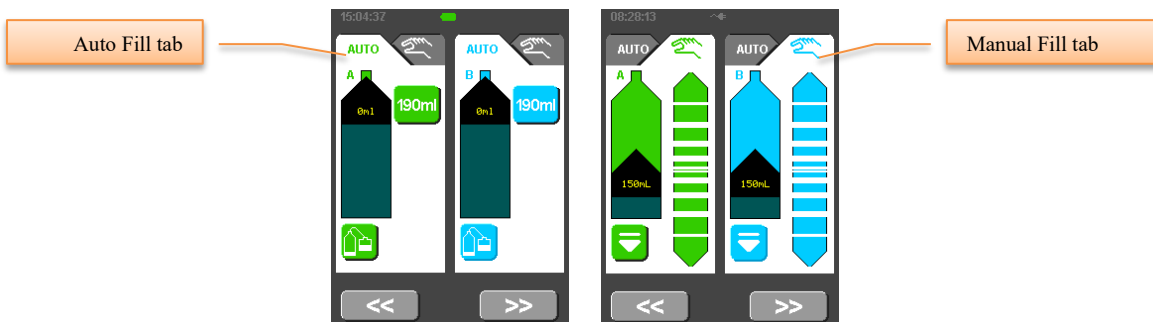

[Dual Only]



Switch between Manual and AutoFill modes using the tabs at the top.

5.3.1. Manual and Auto Filling Procedure

Manual filling	Integral AutoFill with a QFT
1. Mount a new syringe on the injector	
2.  Select  on the touch screen	
3. The plunger will automatically purge the air from the syringe.	
4. Push the QFT onto the end of the syringe. Do not install with excessive force	
5. Insert the QFT into the fluid source and	
6. Fill the syringe with fluid using the manual fill control.	Press the  button on the Auto tab.
7. Expel air	
8. Remove QFT. Connect the disposable tubing set.	
9. Follow the instructions in Section 5.5	
10. Press  button to set the injection parameters	

5.3.2. [Optional] IV Holder

An IV holder (part number: DC039) can be supplied as an optional accessory. This allows IV bags and other items to be hung near the injector.



5.4. [Optional] Off-line Filling



Contrast can be filled off-line using the optional manually-operated Off-line Loader (MDL001). This can improve the workflow by freeing the injector to continue with other procedures.

With the loader lever in the down position, mount a new syringe into the loader and twist a ¼ of a turn to lock it into place.

Place the quick fill tube on the tip of the syringe, being careful not to touch the ends of the tube or the syringe to avoid contamination



Lift the lever to move the piston up the syringe



Insert fill tube into the contrast bottle and slowly draw down the lever to fill the syringe to the desired level, avoiding introducing bubbles into the syringe. Remove and discard the quick fill tube.

To dismount the filled syringe from the Loader, the piston should be moved upwards slightly and then down to disengage from the syringe plunger.³

Twist the disengaged syringe ¼ turn and gently pull out of the Loader.



Mount the filled syringe into the injector. Press the  button on the injector. The injector will automatically detect the filled syringe and will be ready to perform an injection (see section 5.7)

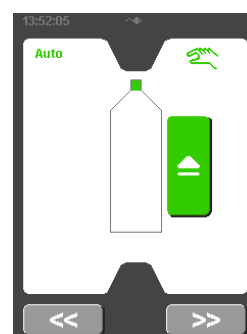



5.5. Connector Tube Installation

1. Ensure all air is purged from the syringe.

³ If the syringe is completely full, moving the piston upwards may eject some contrast. In this situation, turn the syringe a ¼ turn and lift up with the piston engaged. The syringe can then be disengaged without moving the syringe plunger.

2. Remove the connector tube from the package. Remove the proximal-end (orange) dust cover.
3. Attach the connector tube to the syringe, ¼ turn to ½ turn maximum.
4. Once secured, verify that the tubing is not kinked or obstructed.
5. **[Dual only]** If you are using a connector tube with a T-connector, attach the straight portion of the T-connector to the contrast (Syringe A) and the extension to the saline (Syringe B). If the T-connector is connected to Syringe B, priming will not completely fill the connector tubing.



6. Ensure all air is purged from the connector tube using 
7. Rotate the injector head downward.
8. Remove the distal-end (clear) dust cover.
9. Prime forward fully for a wet connection using 
10. Connect to the patient.
11. Press 
12. The injector will then display a check for air notification.

Note: Patency check through aspiration using the injector is not possible when using a check valve on the end of the connector tube. If aspiration is important, remove the check valve from the connector tube and directly connect the connector tube to the catheter.

5.6. Dismounting a Syringe

1. After the procedure has been completed, disconnect the disposable tubing set from the vascular entry device. The disposable tubing set does not need to be disconnected from the syringe.
2. Rotate the syringe approximately ¼ turn counter-clockwise and gently pull the syringe out of the injector head, discarding the syringe with disposable tubing set.

Note: In order to remove the syringe, the last piston motion must be in the forward direction, which is typical. If you cannot remove the syringe, press  to retract, then repeat Step 2.

5.7. Performing an injection

Pressing **>>**, when on the filling screen displays the current protocol screen. The routine protocol screen is described in Section 5.7.1. More complicated multi-phase protocols may also be entered; see Section 5.8.

5.7.1. Routine Protocol Setup

The routine protocol is a simple injection protocol which delivers one phase. The volumes and injection rates entered on this screen are not remembered by the injector when it is powered off.

To alter the default volume and flow rate values of the routine protocol, the use the Options menu from the start screen (see Section 5.9).

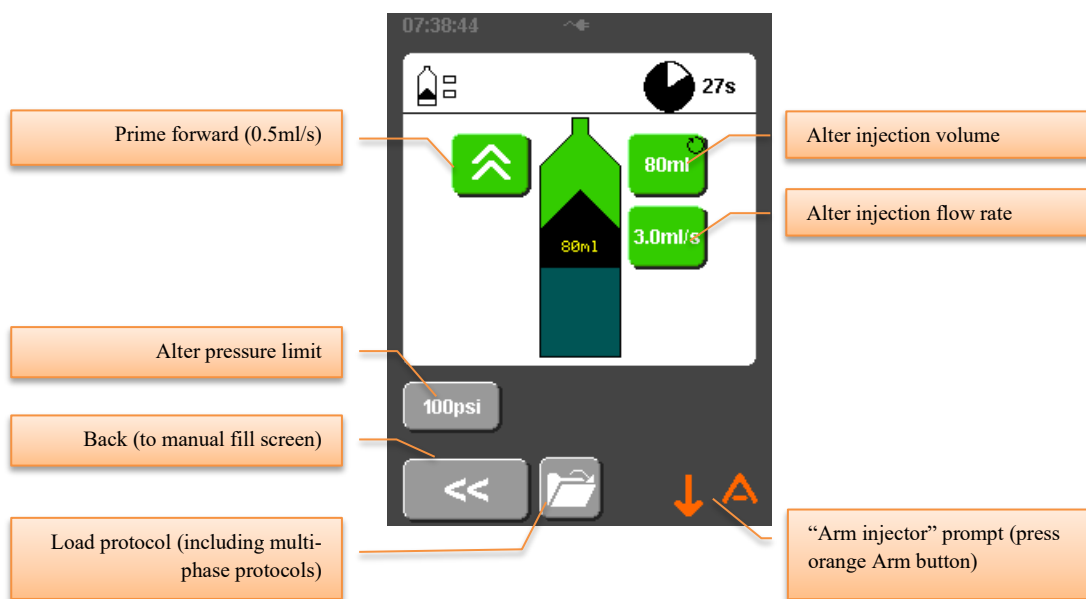

[Dual Only] Saline and Contrast Routine Protocol Setup

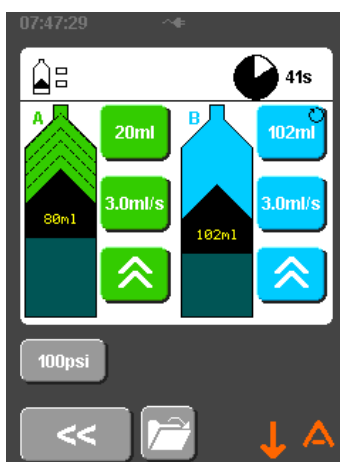

The controls on the Dual injector screen are identical, except that a contrast phase, followed by a saline phase can be programmed.

5.7.2. Arming

Press the  on the injector head to ARM

To disable the ARM state, press 

The injector will time out of the ARM state if the injection is not started within 10 minutes and will return to the protocol screen.

Check for air.

Press the OK button on the touch screen.

The injector is now ready to begin injecting, and the LEDs in the rear of the head module will flash green to reflect this fact.

Tilt the head down before starting the injection to minimise risk of air injection. With the head down, the display will reorient automatically.

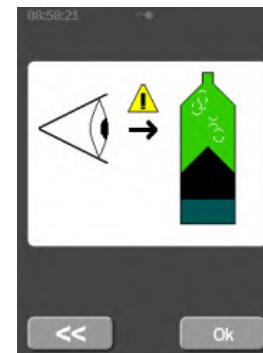

5.7.3. Pressure Graph Display

Prior to starting the injection, the user can chose to either display the syringe status or a real-time pressure graph.

The pressure graph button is a toggle button.



- Plot not highlighted. Syringe status will be displayed during the injection.



- Plot highlighted. Pressure graph will be displayed during the injection.

The selected display will remain throughout the injection.

The pressure graph of the current active phase is always displayed if a multi-phase injection is in progress.

The top screenshot shows the syringe status display. It features a syringe icon with a downward arrow, a flow rate of 4.0ml/s, and a volume of 70ml. A pressure graph button is visible in the top right corner. The bottom screenshot shows the pressure graph display. It features a pressure limit of 300psi, a current pressure of 0psi, and a volume remaining of 85ml. The pressure graph shows a rising curve. Labels with arrows point to the Pressure Limit, Pressure graph, Current pressure, and Volume remaining.

5.7.4. Starting the Injection

Injections may be started using the pressing the green button on the supplied remote control, or the green start button on the touch screen. An optional hand-switch or footswitch can also be used to initiate injections.

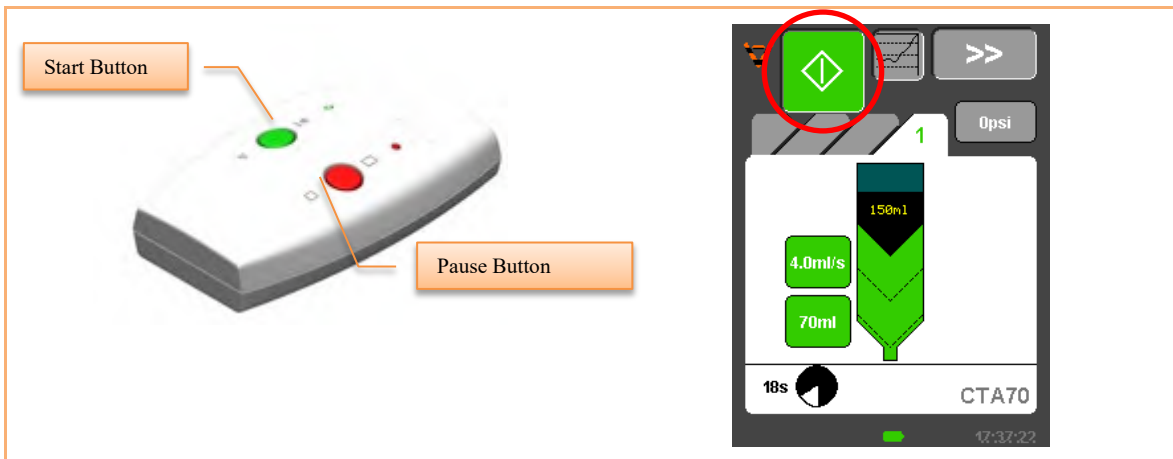

The start button does not need to be held down during the injection.

5.7.5. Halting the Injection

While an injection is in progress, the following screen is shown:

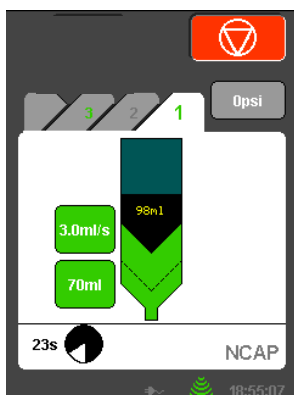

Single

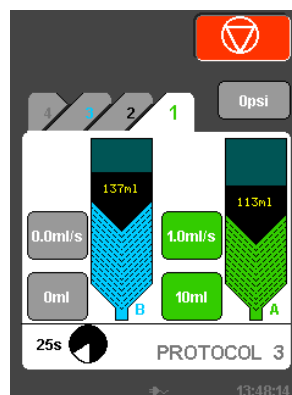

Dual

If the red "Abort" button  is pressed, the injection will stop and display the review screen (See Section 5.7.7).

If the injector screen is touched at any location away from the red "Abort" button, or the red button on the supplied remote control is pressed the injection will halt in Hold mode. The optional hand-switch or footswitch will also halt the injection when pressed during an injection.

The injector will stay in Hold mode, until the injection is resumed using the Start button on the remote or optional hand-switch or footswitch, or pressing the  on the screen.

To abort the injection completely while the injector is in Hold mode, press  and then  on the injector review screen.

5.7.6. Common Injecting Alarms

During an injection, the most likely alarms to occur which result in the injection halting are caused by high pressure or the adaptive flow algorithm slowing the injection speed down to zero (known as a stall alarm). When these alarms occur, the top part of the screen (the status bar) will flash red and the LEDs at the back of the injector head will illuminate red.

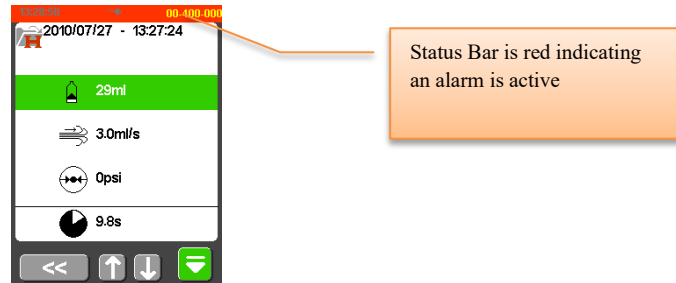

Either of these alarms may be due to obstruction of injection pathway such as a kink in the tubing or the patient moving and compressing the blood vessel where the injecting site is. Please examine the tubing and injection site to clear any obstructions before attempting to resume the injection.



5.7.7. Post-Injection Review

When the injection has completed a summary of the injection details is displayed. The average flow rate, peak pressure and duration are calculated based on the combined contrast/saline injection (including all phases in a multi-phase injection). If the syringe is manually removed at this stage, the piston will automatically retract.

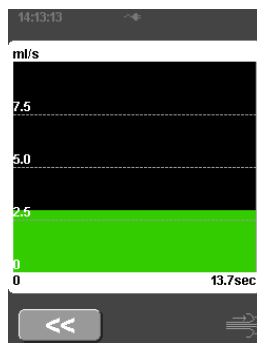
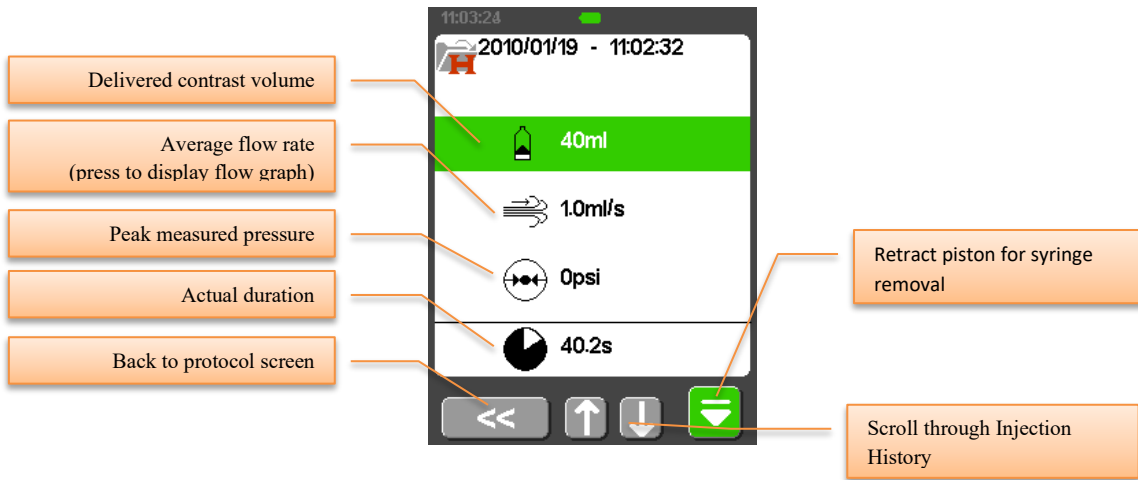

Flow graph (single)

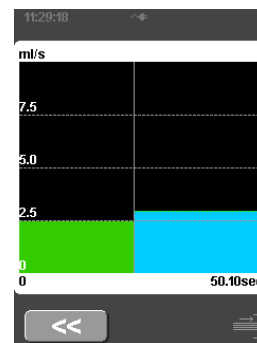

Flow graph (dual)

If the injection reduces the set flow rate by entering into adaptive mode, the indication will be shown as below.

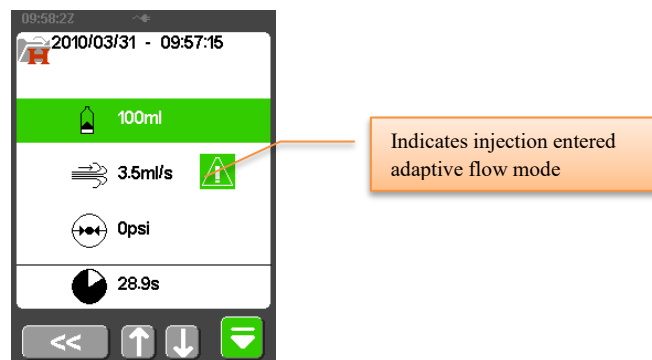

5.7.7.1. [Dual Only] Post-injection Review

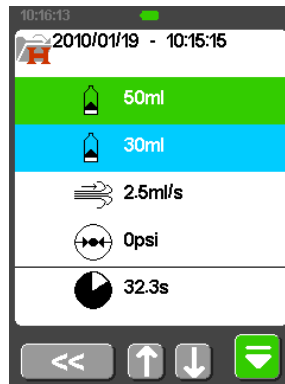

The contrast and saline injection volumes are separately indicated. The average flow, peak pressure and duration are over the combined contrast/saline injection.

5.8. Programming

The injector can be programmed to deliver up to 4 sequential phases of contrast injections, hold phases or delays.

The multi-phase programming mode is entered by pressing the load protocol button  on the routine protocol screen and loading any protocol except the routine protocol.

5.8.1. Multi-phase protocol setup

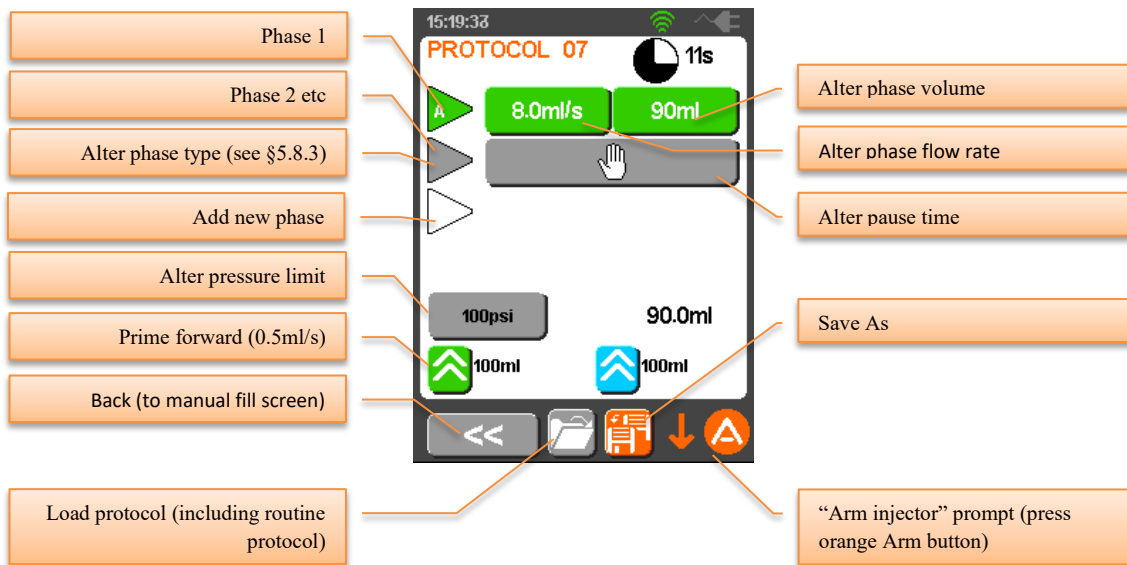

5.8.2. [Dual Only] Multi-phase contrast/saline protocol setup



The Dual injector multi-phase screen is similar but separate contrast and saline phases can be programmed.

5.8.3. Phase Type Selection

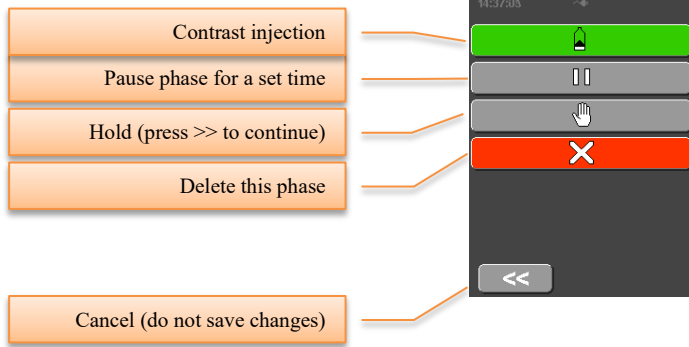

5.8.4. [Dual Only] Phase Type Selection

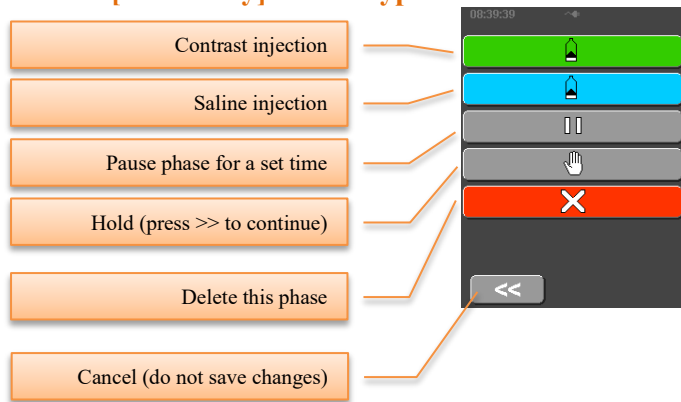

5.8.5. Protocol Selection – Loading

Pressing  on either of the routine protocol or multi-phase protocol screens will cause the injector to display a list of the stored protocols. Select a protocol name you wish to load.

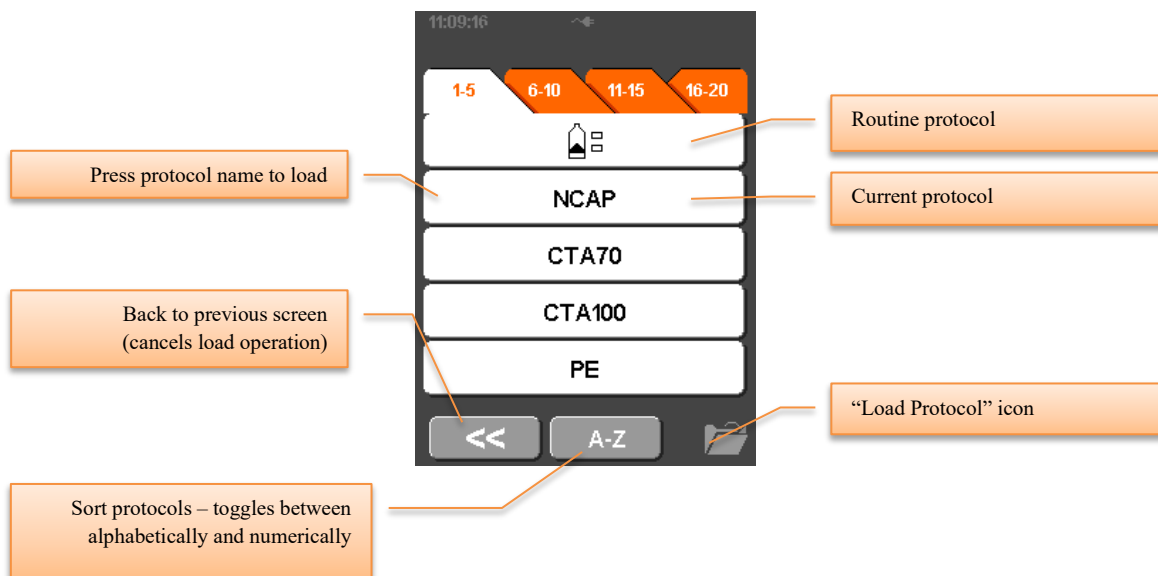

The protocols are saved in numerical slots. The protocols can be sorted alphabetically by pressing the  button. The list will appear as below.

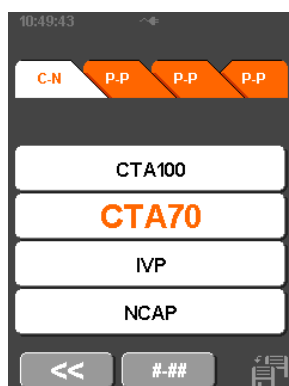

The protocols can be sorted in their numerical order by pressing .



Caution: The injector is pre-loaded with some basic contrast injection protocols to assist the user in getting started. The protocols are a guide only, and should be adjusted to meet the clinical needs of the examination as determined by the user. The risk is minimal, but if the user solely relies on these protocols, optimal contrast enhancement may not always be achieved.

5.8.6. Protocol Selection – Saving

Pressing  on the multi-phase protocol screen will cause the injector to display a list of the stored protocols. Select a protocol name where you want the current protocol to be stored and the injector will then prompt you to enter a new name for the stored protocol.

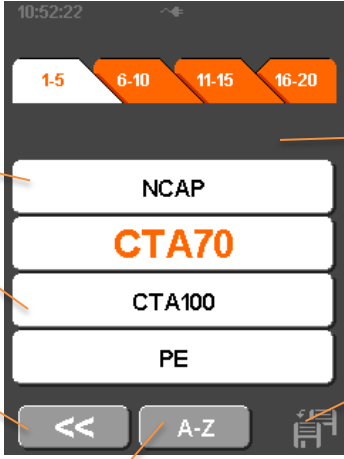

The screenshot shows a mobile interface with a time of 10:52:22. At the top, there are four phase selection buttons: 1-5, 6-10, 11-15, and 16-20. Below these are four protocol name buttons: NCAP, CTA70 (highlighted in orange), CTA100, and PE. At the bottom, there are three buttons: a back arrow (<<), an 'A-Z' button, and a 'Save Protocol' icon (a document with a checkmark). Callout boxes provide the following information:

- Current protocol: Pressing it saves over it** (points to the NCAP button)
- Press a protocol name to save over it** (points to the CTA70 button)
- Back to previous screen (cancels save operation)** (points to the << button)
- Sort protocols – toggles between alphabetically and numerically** (points to the A-Z button)
- “Save Protocol” icon** (points to the document icon)
- The routine protocol cannot be saved over. Use the options menu to change its settings (§5.9)** (points to the 16-20 phase button)

If you do not wish to alter the name, press the OK button and the protocol will be saved with the current name.

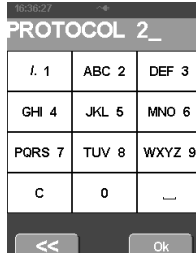

The screenshot shows a screen titled 'PROTOCOL 2_'. It features a 3x3 grid of alphanumeric characters for name entry:

I. 1	ABC 2	DEF 3
GHI 4	JKL 5	MNO 6
PQRS 7	TUV 8	WXYZ 9
C	0	_

At the bottom, there are two buttons: '<<' and 'Ok'. A callout box labeled 'Cancel (do not save changes)' points to the '<<' button.

5.9. Options Menu

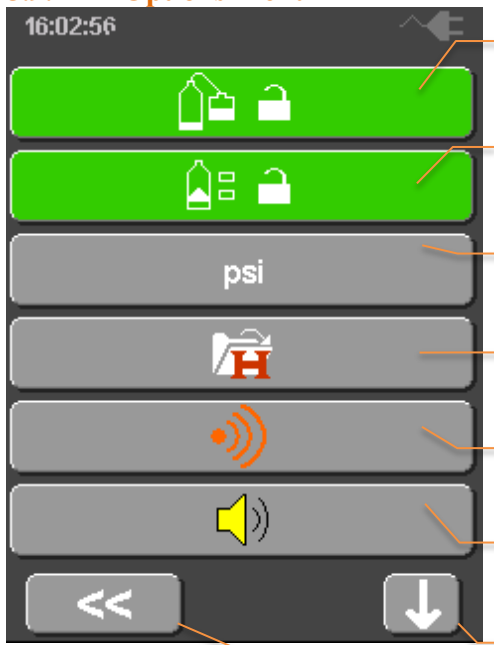

- AutoFill Default:** Alter the default AutoFill volume, shuffle and fill speed for the syringe
- Routine Protocol Defaults:** Alter the default injection volume and speed for the routine protocol
- Pressure Units:** Display in psi, kg/cm² or kPa
- Injection History:** Display details of the previous injections
- Fault History:** Display details of the previous warnings and alarms
- Sound Volume:** Adjusts sounds and alarm volumes on a scale of 1 to 10 (default 7)
- Next Options screen
- Back to Start screen

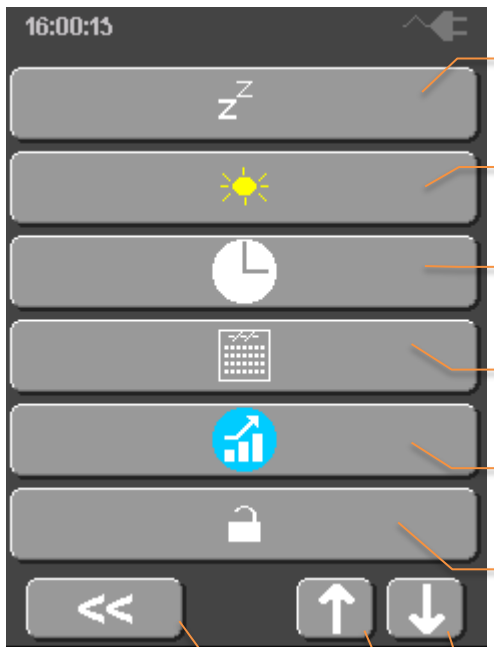

- Power off time:** Time for system to power off automatically when unused. 120min is max and default. 0min = always on
- Brightness:** Set screen brightness
- Time:** Set injector time
- Date:** Set injector date
- Efficacy Data:** Display number of injections, over-pressures and user aborted injections
- Protocol Lock:** Lock protocols and auto fill parameters so they cannot be overwritten
- Next Options screen
- Previous Options screen
- Back to Start screen

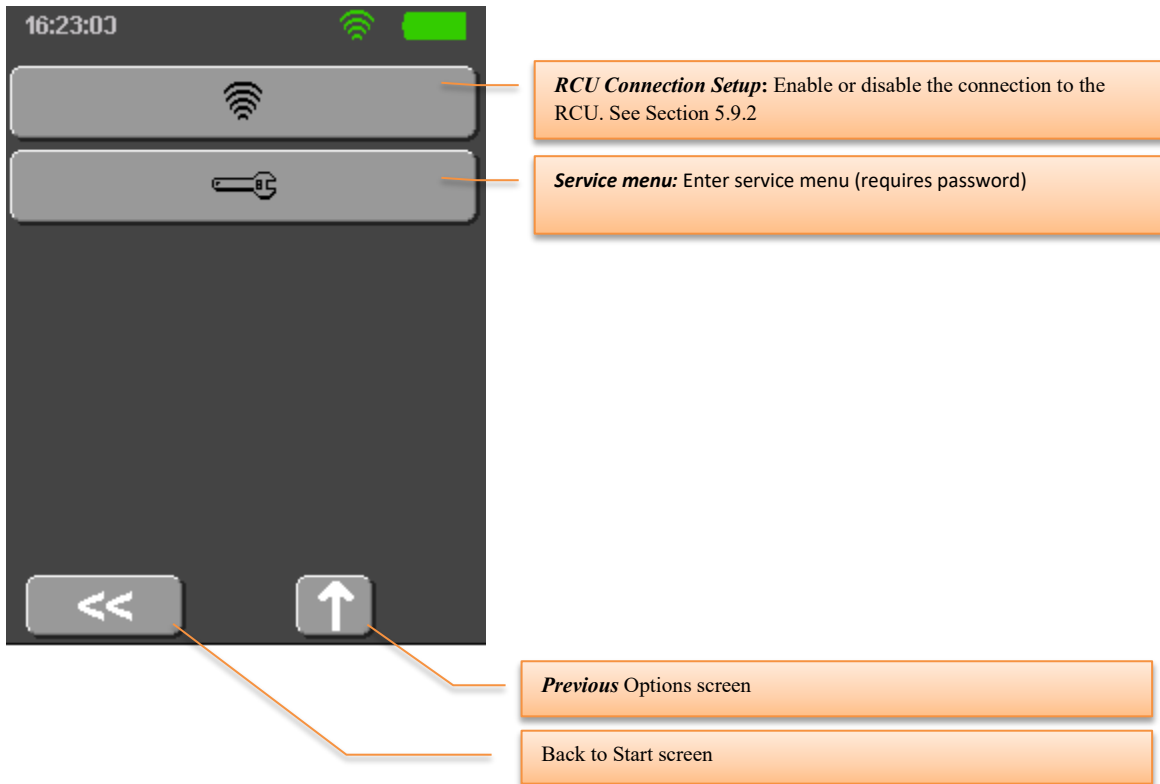

5.9.1. [Dual Only] Option Menu

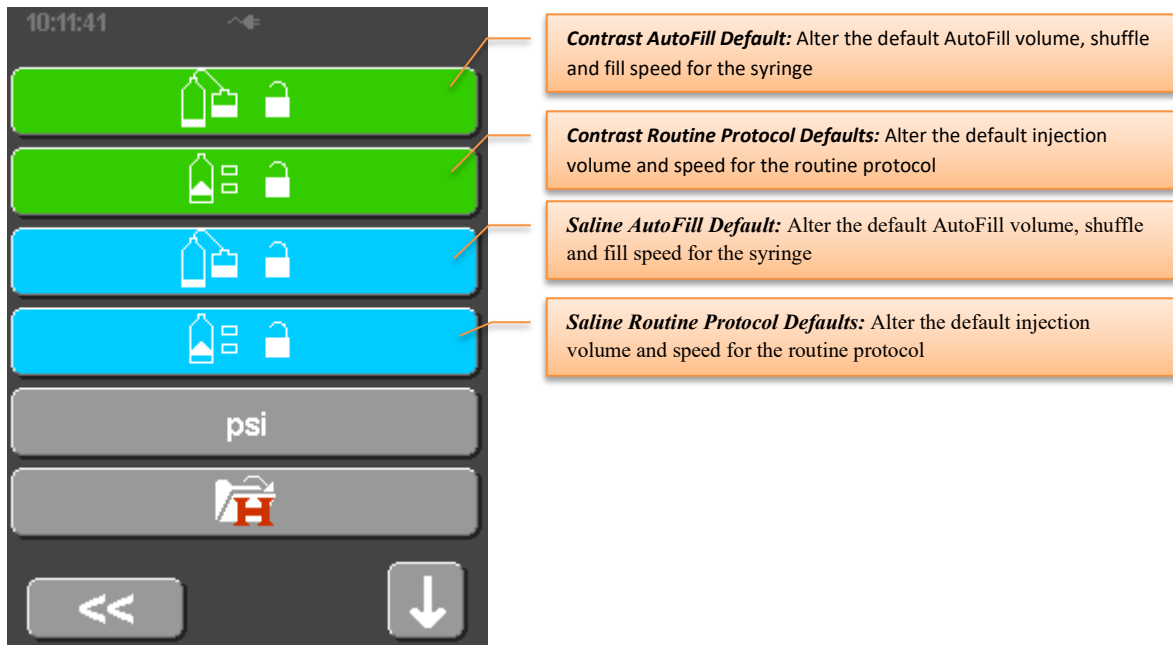

Other menu options are identical to the Single model.

5.9.2. [RCU models] RCU Connection Setup

Pressing the RCU Connection Setup displays the configuration for the wi-fi connection.

The Wi-Fi connection can be enabled/disabled as required.

(The Type setting cannot be changed).



The NetID should be set to match that selected on the RCU (see Section 5.9.2).



5.9.3. Autofill Default Options

These options govern the behaviour of the autofill feature on the fill screen. Note that only the autofill volume can be changed on the fill screen. The shuffle volume and the fill speed will always be set to the values entered here.

If the autofill volume is changed on the fill screen, the new value will remain in effect until the injector is powered off and on again, when the default value on this options screen will be reloaded.

The screenshot shows a numeric keypad interface for setting autofill defaults. The top row displays three fields: '190.0ml' (Autofill Volume), '0.0ml Shuffle' (Autofill Shuffle Volume), and '9.0ml/s' (Autofill Speed). Below these is a 3x3 numeric keypad with a backspace arrow, a '0' key, and a decimal point key. At the bottom are two buttons: a left-pointing arrow labeled '<<' and a green 'Ok' button.

Callouts and their descriptions:

- Autofill Volume:** The default volume to appear on the Autofill screen
- Autofill Shuffle Volume:** The plunger will shuffle back and forward by this amount at the start of Auto-filling in order to help reduce the number of bubbles created during filling
- Autofill Speed:** (points to the 9.0ml/s field)
- Enter new values by pressing on the numbers** (points to the numeric keypad)
- Backspace:** Delete last character (points to the left arrow key)
- Accept changes; Return to Option Menu** (points to the 'Ok' button)
- Discard Changes; Return to Options menu** (points to the '<<' button)

5.9.4. Routine Protocol Default Options

These options govern the default behaviour of the routine protocol as follows. Note that all three injection parameters may be over-riden by entering a new value on the protocol screen prior to performing the injection. When the injection completes, the default option values set here will be reloaded.

The screenshot shows a numeric keypad interface for setting routine protocol defaults. The top row displays three fields: '...' (Routine Protocol Contrast Volume), '3.0ml/s' (Routine Protocol Contrast Flow Rate), and '300psi' (Routine Protocol Pressure Limit). Below these is a 3x3 numeric keypad with a backspace arrow, a '0' key, and a syringe icon key. At the bottom are two buttons: a left-pointing arrow labeled '<<' and a green 'Ok' button.

Callouts and their descriptions:

- Routine Protocol Contrast Volume:** The default injection volume to appear on the Routine Protocol screen. The setting shown indicates that All Volume has been selected
- Routine Protocol Contrast Flow Rate:** The default injection speed to appear on the Routine Protocol screen.
- Routine Protocol Pressure Limit:** The default pressure limit to appear on the Routine Protocol screen.
- Enter new values by pressing on the numbers** (points to the numeric keypad)
- All Volume;** The injector will simply inject all of the volume in the syringe (points to the syringe icon key)
- Accept changes; Return to Option Menu** (points to the 'Ok' button)
- Discard Changes; Return to Options menu** (points to the '<<' button)
- Backspace:** Delete last character (points to the left arrow key)

5.10. [RCU models] Operation Description with Remote Control Unit

This section covers the operation of the models:

- ◆ DC009SW
- ◆ DC009DW

In these models, the function of the injector can be controlled by a tablet PC, remotely-connected to the injector via peer-to-peer Wi-Fi connection.

The functionality of the injector is identical to that of the non-RCU models DC009S and DC009D.



5.10.1. RCU Features–

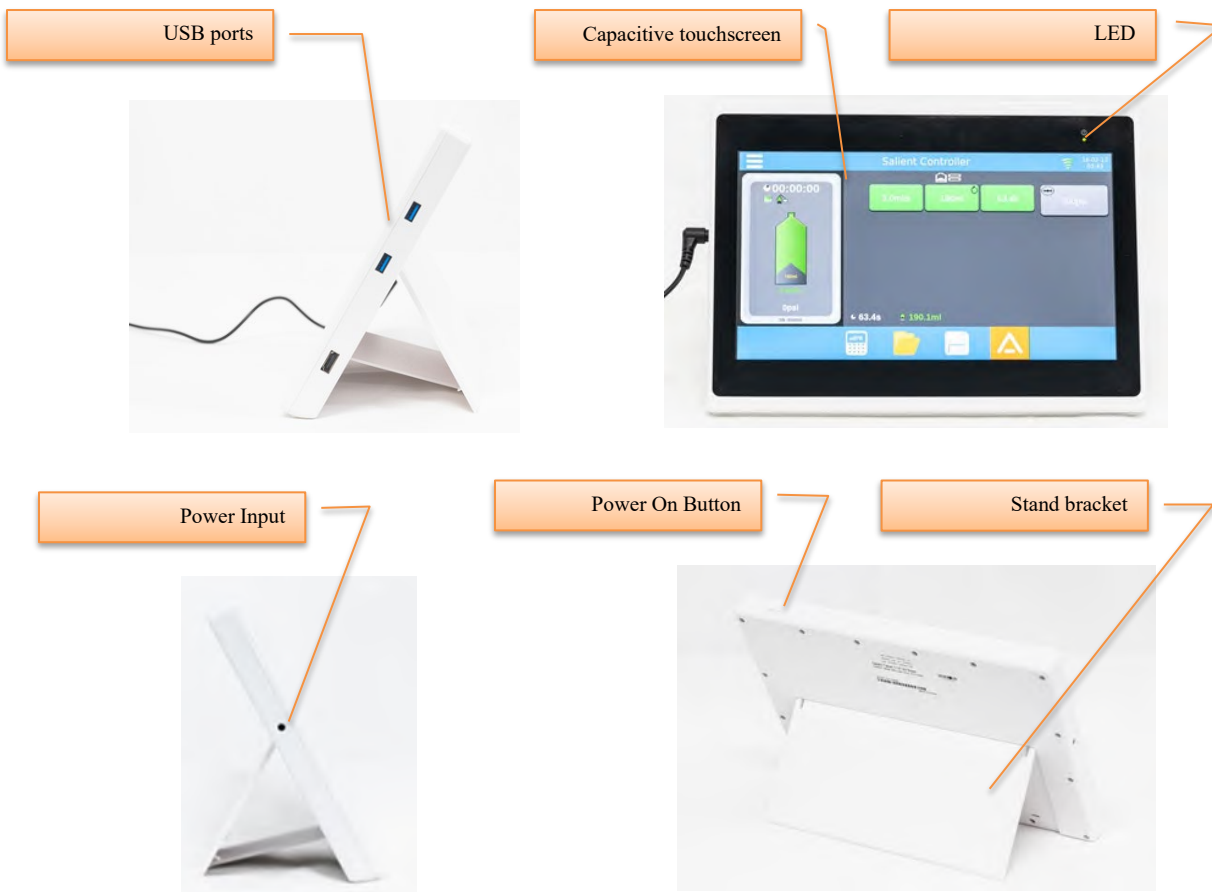

Note: The touch screen does not have multi-touch functionality. To avoid incorrect input, please touch one control at a time

5.10.2. The Injector and the RCU

The RCU is designed to provide continuous status information on the injector, and full control of the injector⁴. When connected with either a single or dual syringe model injector, the RCU will display the parameters and controls appropriate to that model.

5.10.3. Turning the System On / Off

The RCU is powered on by pressing the “Power Button” shown in Section 5.10.1.

Plug in a power cable to RCU and press and hold the on/off button until the RCU starts. Check that power LED is flashing.

Keep the RCU connected to power when operating.

The first screen displayed is the Injector Controller screen, where the injection parameters can be set, and the injection initiated.

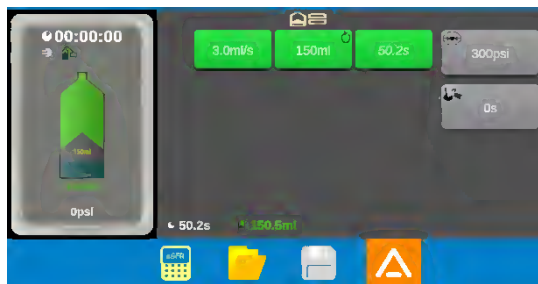

To turn off the RCU, long press the Standby button.

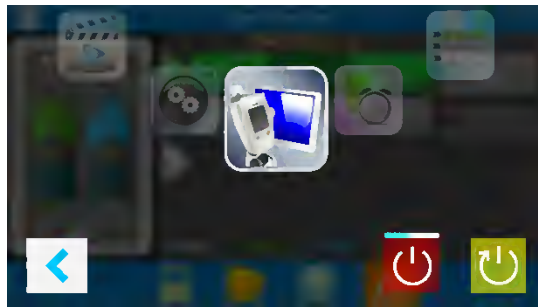

To restart, long press the Restart button.

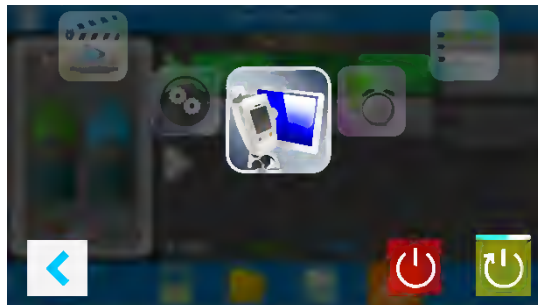

⁴ With one exception, during filling. See Section 5.10.5.

5.10.3.1. Injector Link Status

RCU Manager updates the link status in real time. It is important to ensure the link is connected before start controlling injector.



Disconnected. RCU will attempt to connect to the injector if no connection is found.



Connected. Number of segments reflects the strength of signal.



Communication Issue. The selected channel is already being used, or the wrong protocol version is used.

5.10.3.2. Establishing/Re-establishing Injector Link

If the link to the injector is lost, a warning is indicated on the RCU screen.

Ensure the injector is turned on and set to the correct Wireless ID as the RCU (see Sections 5.9.2 and 5.10.22).

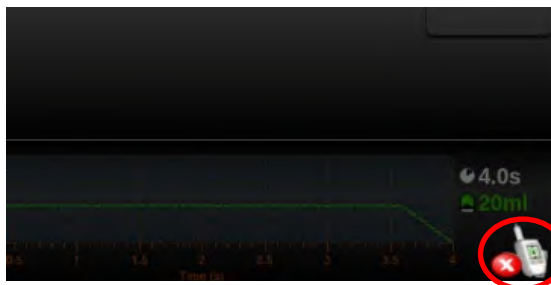

Restart both the injector and RCU to restore the link.

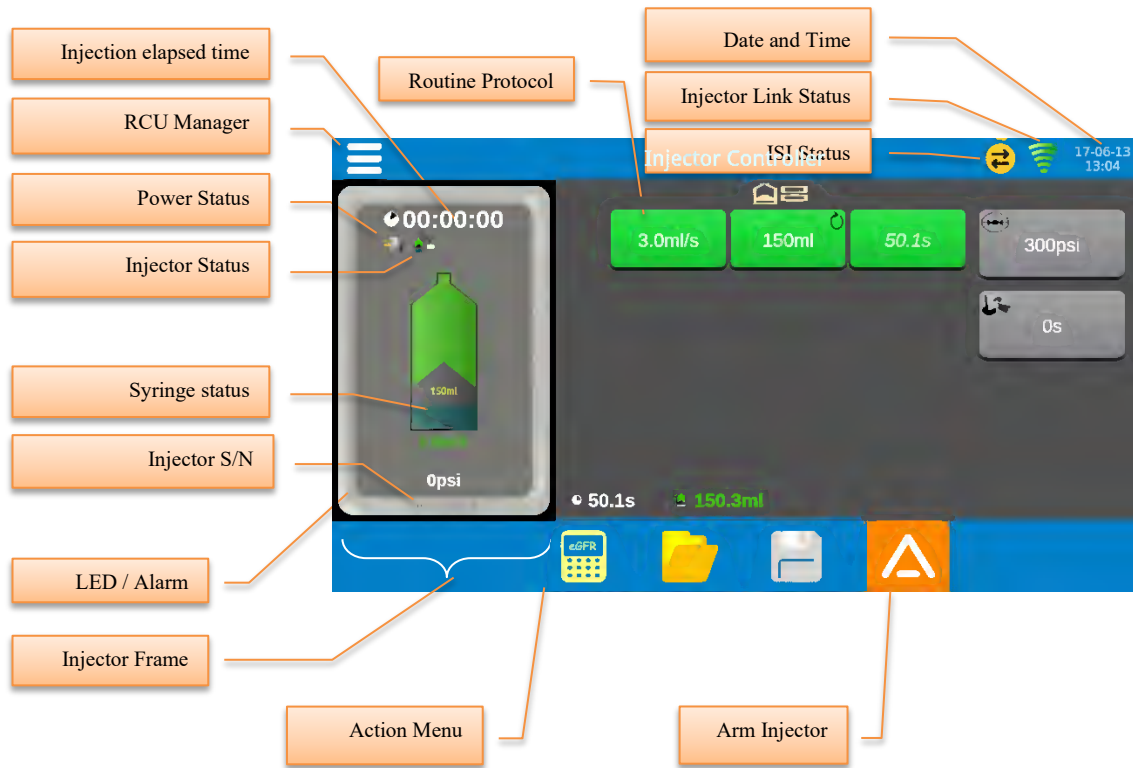

5.10.4. Injector Controller Application



Injector Controller Action Menu

	<p>GFR Calculator: Uses the Modification of Diet in Renal Disease (MDRD) Study equation to estimate an appropriate contrast dose based on patient parameters.</p>
	<p>Saved Protocols: View and select saved injection protocols stored on the RCU.</p>
	<p>Save As Protocol: Save the current protocol under another protocol name. This button is disabled when grey.</p>

5.10.4.1. Date and Time

Date and time is displayed in <YYYY/MM/DD HH:MM> format.

These values are synchronised from the injector and updated in real time.

5.10.4.2. Injector and Syringe Status, Alarms and Indicators



RCU displays current injector and syringe status in real time in 500ms intervals. For Single injector models, only one syringe icon will be displayed

Syringe Status parameters are:

- ◆ Filled volume
- ◆ Flow rate
- ◆ Pressure
- ◆ Injection volume indicator: displayed while in 'Protocol Edit Screen'







[Dual Only]. If the RCU is interfaced to a Dual injector, both syringes are shown. The pressure of the currently-active syringe is displayed.



Around the injector status screen, the Injector Frame displays the current status of the injector

Event	LEDs at rear of injector head	LCD Display
<i>Injector Error Condition</i> ⁵	Flash Red	Red Status Bar
<i>Warning</i>	Flash Orange	Orange Status Bar
<i>ARMED State</i>	Flash Green	Flashing ARM symbol
<i>INJECTING State</i>	Rotate Green	Flashing Syringe
<i>INJECT COMPLETE State</i>	Stop rotating (orange if adaptive flow occurred, green otherwise)	Nothing
<i>Touch screen Button press</i>	Nothing	Nothing
<i>Motor movement</i>	Rotate green	Animated Syringe
<i>Adaptive Flow (Pressure Limiting)</i>	Rotate orange	Orange Status Bar

⁵ Notes: There are no alarm presets in the injector.

All error conditions indicate a fault with the injector and the injection has stopped. Warnings and other indicators indicate continued but changed operation of the injector.

Power Status	
	Battery Low
	Battery half
	Battery full
	Mains power

Filling/Injection Status	
	<p><Animation> Injector is in filling status</p>
	<p><Animation> Injection in progress</p>

5.10.4.3. Elapsed Time



RCU displays the elapsed time since the last injection start.

Format is <HH:MM:SS> and updated every 1 second.

The time value is reset when new syringe is engaged or by pressing the timer display and holding for 2 seconds.

The time value does not wrap; max time displayed is “99:59:59”.

5.10.5. Filling State

The RCU does not support filling the syringe. The filling should be performed at the injector, or using the optional off-line loader.

While the injector is in ‘Filling State’, ‘ARM’ is disabled in RCU.

5.10.6. Routine Protocol

Change the flow rate, volume and pressure limit of the routine protocol, if required, by pressing the buttons and entering the desired values.

The injection duration is automatically calculated.



[Dual Only] Program the contrast and saline parameters as required.



5.10.7. Arming

When the protocol has been programmed, press the  button to arm the injector. A confirmation of arming from the fill screen is displayed.

Select the  button to continue.

NOTE: Arm can also be triggered from injector.

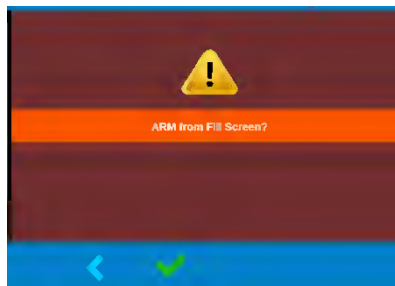

5.10.8. Check for Air

The injector and RCU will show 'Check for Air' screen simultaneously.

Select the  button to continue.

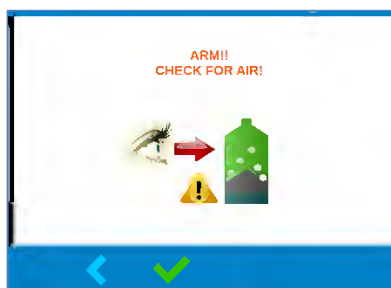

5.10.9. Starting the Injection

Review the protocol displayed.

Select the  button on 'Start Injection' Screen.



5.10.10. Injection in Progress

The injection can be monitored in progress from the RCU. While an injection is in progress, the RCU will:

Update the plot display (flow rate and pressure) in real time

Display the injection progress information in real time

Play LED animation

Play injection sound

If the  button is pressed, the injection is paused. When paused:

Pressing the  button will stop injection

Pressing the  button will resume injection

When injection is completed, all injection control buttons will disappear. The user can then proceed to other screens (e.g. view history, edit protocol).



Injection Information

Current Phase information

Injection Plot
(Pressure & Flow Rate)

Injection Control button
(changes depending on injection state)



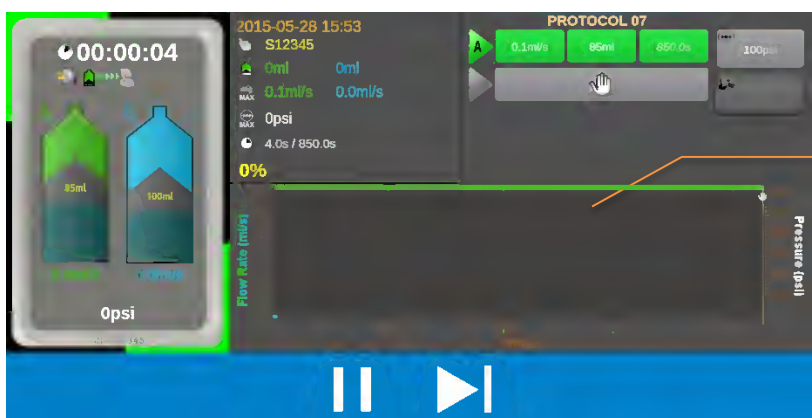

[Dual Only] The injection screen on a dual injector shows the status of both syringes, and the injection plot of the entire injection.



Coloured bars showing duration of each phase

5.10.11. Injection Control Buttons

If for any reason, the injection needs to be paused or aborted, select the RCU injection control button on the Injection in Progress screen.

	Resume inject
	Pause inject
	Skip phase – for dual routine injections, or multi-phase injections, allows the user to skip to the next phase
	Abort inject
	<Blink> Aborting inject

5.10.12. Injection Review

At the end of the injection, the details of the injection can be reviewed, either in plot format or table format.

These formats can be toggled using the  or  buttons.

Plot format

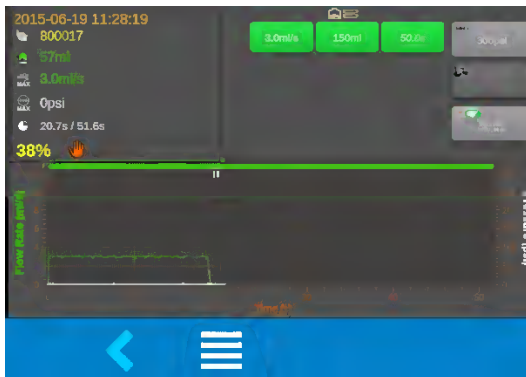
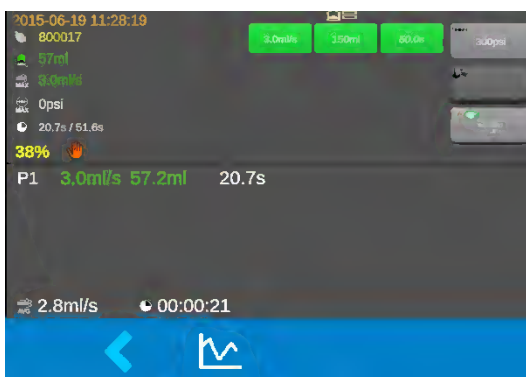









Table format



5.10.12.1. Injection Review Control Buttons

	Injection Review Table Mode
	Injection Review Plot Mode

5.10.12.2. Injection Complete Status Icons

	Injection completed
	Injection terminated with over pressure
	Injection aborted from user
	Injection terminated with timeout
	Injection terminated with an alarm event

5.10.13. Protocol Edit

Multiphase injections can be programmed and saved

The screenshot shows the 'NCAP' protocol edit interface. On the left, a syringe icon displays '00:00:00' and '190ml'. The main area shows two phases, 'A', with parameters: Phase 1 (3.0ml/s, 70ml, 23.3s) and Phase 2 (3.0ml/s, 30ml, 10.0s). A pressure control section shows '300psi' and '0s'. At the bottom, a blue bar contains icons for calculator, folder, save, and arm. Callout boxes on the right identify the following elements:

- Edit protocol type
- Protocol name
- Edit phase parameters
- Edit max pressure
- Summary
- Arm
- Protocol Save
- Protocol Open

[Dual only] The Dual model injector will display the protocol for both syringes

The screenshot shows the 'PROTOCOL 07' interface for a dual syringe model. On the left, two syringe icons are shown with '85ml' and '100ml' respectively. The main area shows phase 'A' with parameters: 8.0ml/s, 150ml, 18.8s. A pressure control section shows '100psi'. At the bottom, a blue bar contains icons for calculator, folder, save, and arm. The status bar at the bottom shows '18.8s', '150.0ml', and '0.0ml'.

Protocol Summary View shows:

- ◆ Overall phase information in terms of time.
- ◆ Overall phase information in terms of volume.

5.10.14. Edit Lock

The injector and RCU do not allow the user to edit protocol parameters simultaneously; only one device is allowed to enter 'edit mode'. The other device is locked while editing is performed.

When RCU is locked 'Edit Lock' icon is displayed in Injector Status frame and will not respond to any button press events that are related to editing protocol parameters.

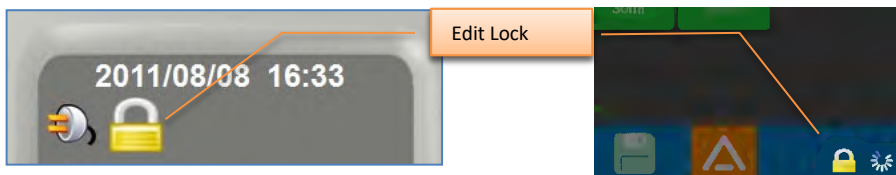

Protocol being edited on the RCU – Injector is locked.

Protocol is being edited on the Injector – RCU is locked.

5.10.15. Parameter Value Edit

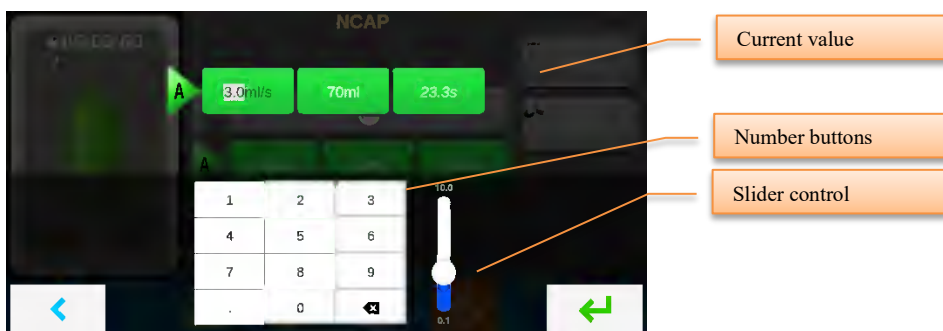

Parameter values can be modified by:

- ◆ Pressing number button,
- ◆ Move slider bar control, or
- ◆ Tap top/bottom area of slider bar to increment/decrement a single step.

5.10.16. Injecting remaining volume

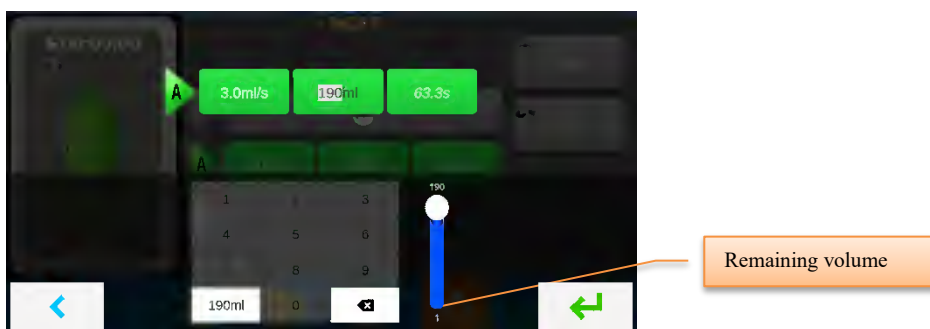

The remaining volume of the syringe can be injected by pressing the button showing the remaining volume.

5.10.17. Edit Phase Type

Each phase can be programmed to be one of four phase types.

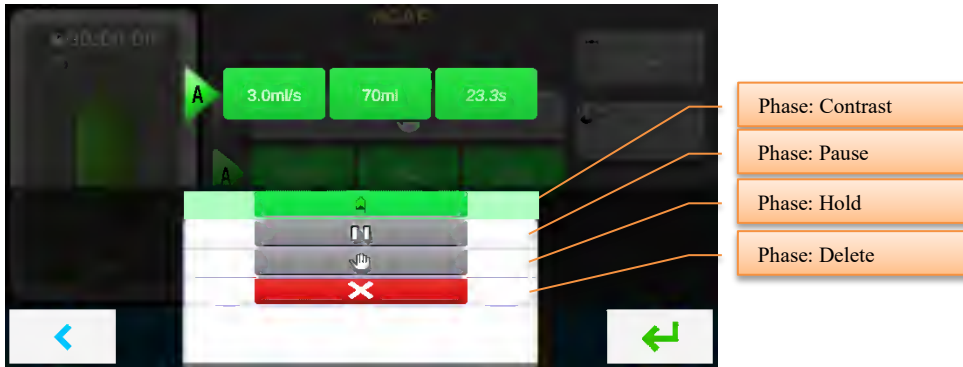

[Dual only] In addition to the four phase types above, a saline injection phase can also be selected

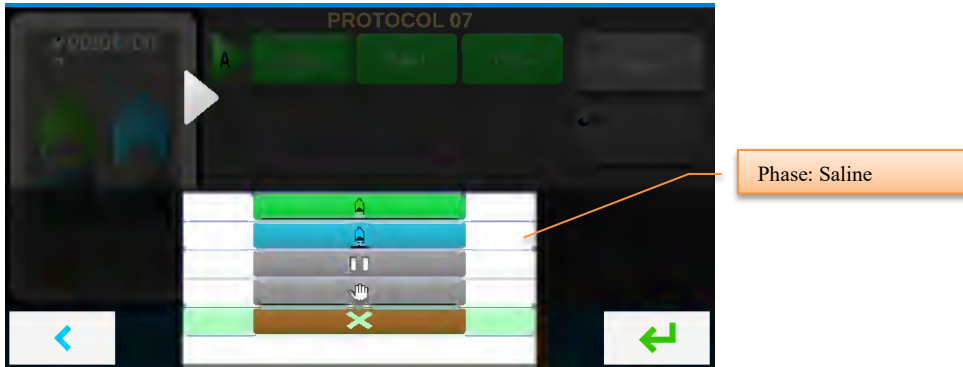

5.10.18. Open Protocol



A previously saved protocol can be loaded by selecting the  button. Scroll through the saved protocols and tap on the protocol desired.

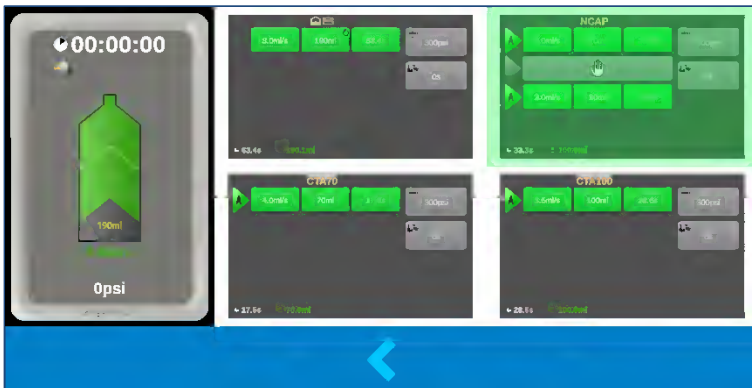

5.10.19. Protocol Save



The current programmed protocol can be saved to a new protocol slot by pressing the  button. Scroll through the list to select the protocol slot desired.

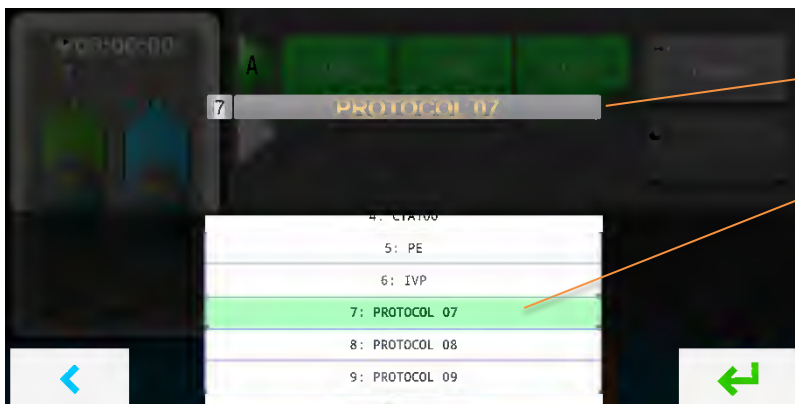

Change protocol name

Select Protocol

5.10.20. Common Injecting Alarms / Warnings

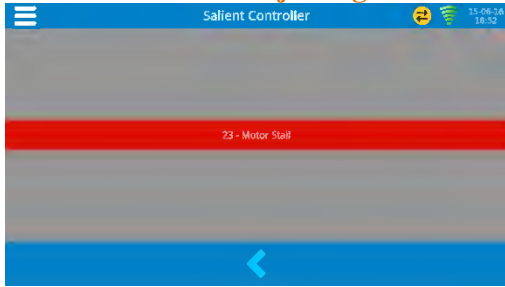

During an injection, the most likely alarms to occur which result in the injection halting are caused by high pressure or the adaptive flow algorithm slowing the injection speed down to zero (known as a stall alarm).

When these alarms occur, RCU will:







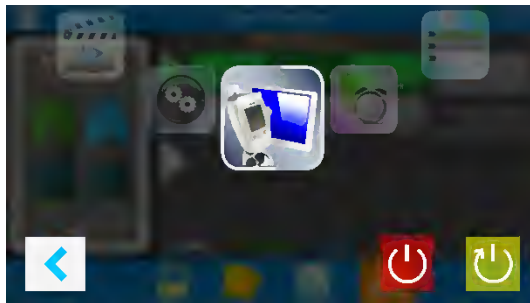

- ◆ Display 'Alarm' screen or 'Warning' screen
- ◆ Play LED flashing, alarm (red), warning (orange)

5.10.21. RCU Manager

RCU Manager provides interface to:









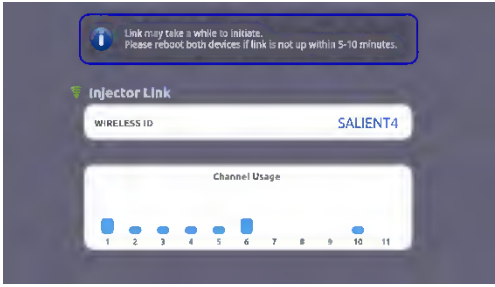

- ◆ Launch RCU Application
- ◆ Manages wireless/wire connection to injector
- ◆ Setup / Configuration
- ◆ Provide service menus
- ◆ View videos and software information

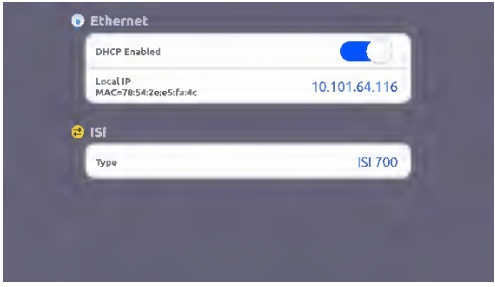

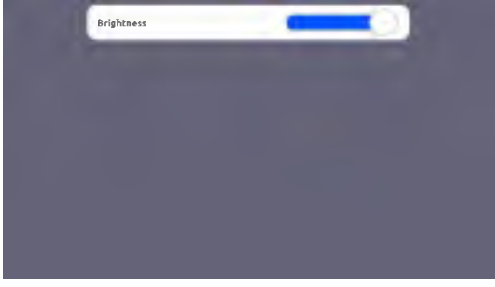
	<p>Injector Controller: This is the application used to control the paired injector.</p> <p>This application is set to run as default at start-up. This can be changed in the RCU Setup – Injector Controller screen (see Section 5.10.22)</p>
	<p>History Viewer: Stored injections performed while the RCU was interfaced with the injector is stored in the RCU memory and can be reviewed from this application</p>
	<p>Protocol Manager: Protocols can be saved or restored from a removable USB memory drive.</p>
	<p>Media Player: The RCU stores a number of training videos that can be used to familiarise new users with the features of the injection system.</p>
	<p>RCU Setup – Section 5.10.22</p>
	<p>Service Options menu [locked, accessible by authorised service personnel only]</p>
	<p>RCU Information – information on RCU software and hardware version.</p>
	<p>Standby Button</p>
	<p>Reset RCU Button</p>

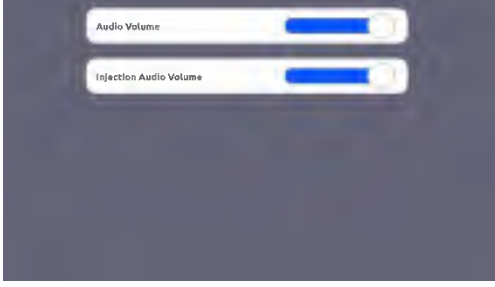
5.10.22. RCU Setup

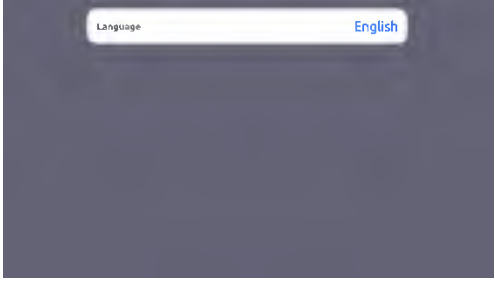
Press the  button on the Action bar to access the setup options

	 <p>Configure the wireless link to the injector. The Wireless ID should match that set on the injector (see Section 5.9.2).</p>
	 [Optional] <p>Enable or disable the interface between the RCU and the scanner (see Section 5.11).</p>
	 <p>Set the screen brightness.</p>
	 <p>Set the volume of the RCU sounds.</p>
	 <p>Select from the available languages.</p>

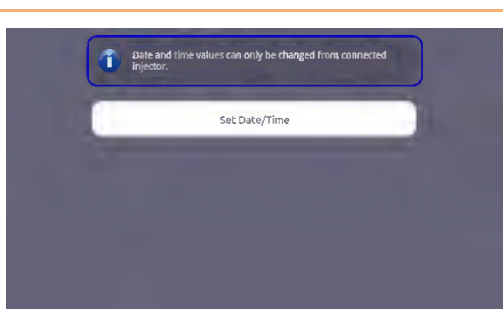
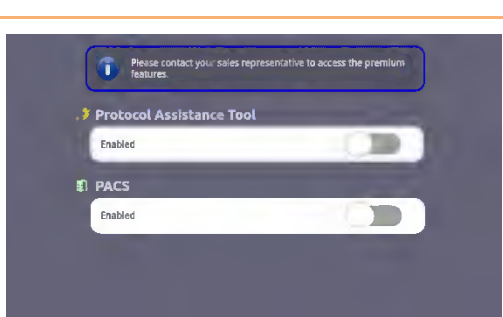



	<p>User Data</p> <p>Injection history can be downloaded to any formatted USB stick.</p>																
	<p>Date & Time</p> <p>(Reminder screen). Change the date and time of the system on the injector.</p>																
	<p>Premium Features</p> <p>Additional software features, if enabled, can be turned on or off. Premium Features can only be enabled by an Imaxeon service or sales representative.</p>																
 <table border="1" data-bbox="321 1441 651 1717"> <tbody> <tr> <td>Local AE Title</td> <td>IMAXEON_RCU</td> </tr> <tr> <td>Study Description</td> <td>INJECTOR_SECONDARY_CAPTURE</td> </tr> <tr> <td>MWL AE Title</td> <td>MWL</td> </tr> <tr> <td>MWL IP</td> <td>10.101.64.85</td> </tr> <tr> <td>MWL Port</td> <td>6104</td> </tr> <tr> <td>PACS AE Title</td> <td>IMAX</td> </tr> <tr> <td>PACS IP</td> <td>10.101.64.113</td> </tr> <tr> <td>PACS Port</td> <td>104</td> </tr> </tbody> </table>	Local AE Title	IMAXEON_RCU	Study Description	INJECTOR_SECONDARY_CAPTURE	MWL AE Title	MWL	MWL IP	10.101.64.85	MWL Port	6104	PACS AE Title	IMAX	PACS IP	10.101.64.113	PACS Port	104	<p>Enabling PACS will display a set of configuration options to enable connection to the hospital network. Consult your onsite IT for the appropriate settings.</p>
Local AE Title	IMAXEON_RCU																
Study Description	INJECTOR_SECONDARY_CAPTURE																
MWL AE Title	MWL																
MWL IP	10.101.64.85																
MWL Port	6104																
PACS AE Title	IMAX																
PACS IP	10.101.64.113																
PACS Port	104																

5.10.23. History Viewer



From the RCU Manager, press the  to view the details of recent injections.



	Injection Review Table Mode
	Injection Review Plot Mode
	Delete Injection Record
	Export Injection History Data

Note: Only injections recorded while the RCU is connected to the injector and controlled from the Injector Controller screen are stored in the RCU. Injections performed by the injector while disconnected from the RCU are not stored on the RCU.

Note: To export injection history data, navigate to the injection history page and insert USB drive into one of the RCU USB ports. Wait for the export button to appear and press it.

5.10.24. Protocol Manager

Injection protocols can be saved to and from USB memory devices.

5.10.24.1. Saving Protocols

- ◆ Plug in the formatted USB device into an available USB port on the RCU.

- ◆ From the RCU Manager, press the  button

- ◆ Select the Injector-to-USB download as shown below and press 

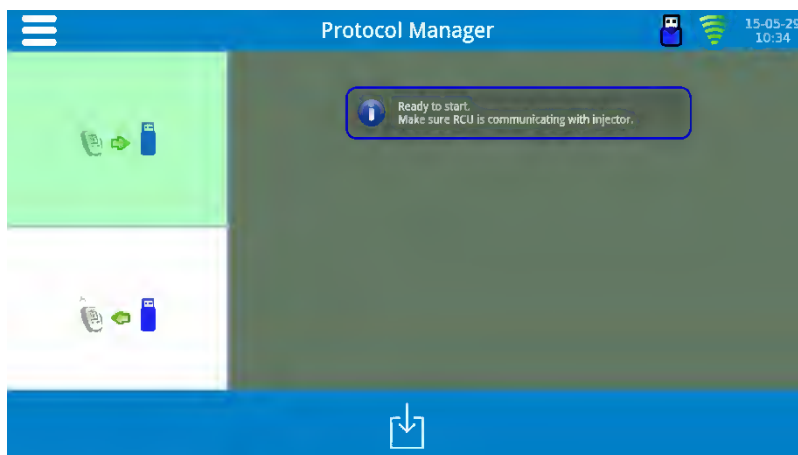

5.10.24.2. Loading Protocols

- ◆ Plug in the USB device containing the saved protocols into an available USB port on the RCU.

- ◆ From the RCU Manager, press the  button.

- ◆ Select the USB-to-Injector upload as shown below and press 

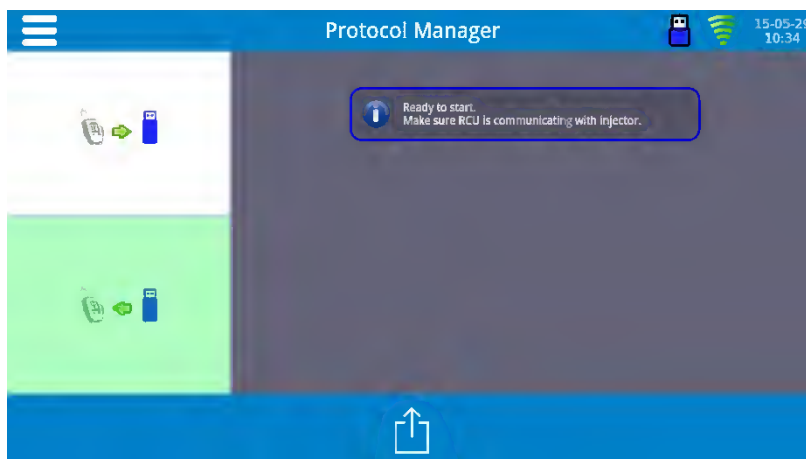

5.10.25. eGFR (glomerular filtration rate) Calculator

The RCU includes a calculator to assist the clinician in estimating the safe volume of contrast dose.

In adults, the best equation for estimating glomerular filtration rate (GFR) from serum creatinine is the isotope dilution mass spectrometry (IDMS)-traceable Modification of Diet in Renal Disease (MDRD) Study equation.⁶

All laboratories should be using creatinine methods calibrated to be IDMS traceable.

This IDMS-traceable MDRD study equation calculator is for use with Scr reported in mg/dL.

$GFR (mL/min/1.73 m^2) = 175 \times (Scr)^{-1.154} \times (Age)^{-0.203} \times (0.742 \text{ if female}) \times (1.212 \text{ if African descent})$.



Warning: The recommended contrast volume calculated by the eGFR calculator **does not alter the programmed volume** in the current injection protocol. The clinician should use the result, in combination with clinical experience to decide on the dose and separately program the volume into the injection protocol.



Warning: The model for the calculation is applicable for adults only. The MDRD calculation is not recommended for paediatric patients.



From the Injector Controller screen, press

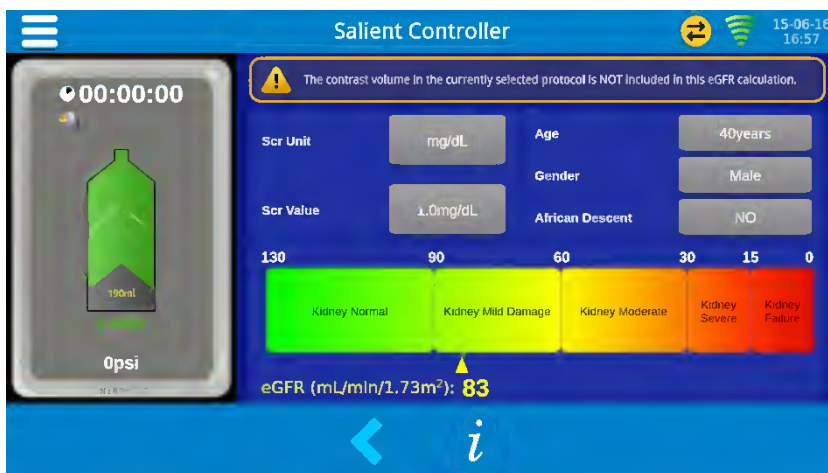

Enter the patient data and assess the appropriate contrast dose accordingly.

⁶ Reference: Levey AS, Coresh J, Greene T, Stevens LA, Zhang YL, Hendriksen S, Kusek JW, Van Lente F; Chronic Kidney Disease Epidemiology Collaboration. Using standardized serum creatinine values in the modification of diet in renal disease study equation for estimating glomerular filtration rate. *Ann Intern Med.* 2006 Aug 15;145(4):247-54.

5.11. [Optional] DC200 Scanner Interface

The Imaging System Interface (DC200) is an option that allows the injector to interface with a CT scanner. It obtains its power from the injector Remote Control Unit option USB port. It interacts with the injector and scanner through direct cable connections. Once the DC200 Module is installed and configured on the injector Remote Control Unit, it allows the scanner and injector to interact with each other and provide functionality as outlined in this manual.

5.11.1. Overview

With the DC200 module installed, the injector system can function independently or coupled to the scanner. Depending upon what mode of operation the scanner is in, this link can allow the scanner to automatically request the initiation of an injection, or permit the injector to automatically request the initiation of a scanning procedure.

Note: The scanner **CANNOT** override any injector operation that is considered safety critical; for example, check for air, hold during an injection or stopping an injection.

Note: The scanner manufacturer and/or user must make the final determination of the mode of operation for the coupled injector and scanner. The scanner manufacturer is responsible for providing operation instructions for their system.

5.11.2. DC200 Scanner Interface Setup

Connect the DC200 module to the RCU using the USB cable provided.



Connect the DC200 module to the scanner using an appropriate cable (Philips or Hitachi – consult your Imaxeon sales or service representative)

Enter the RCU Options screen.

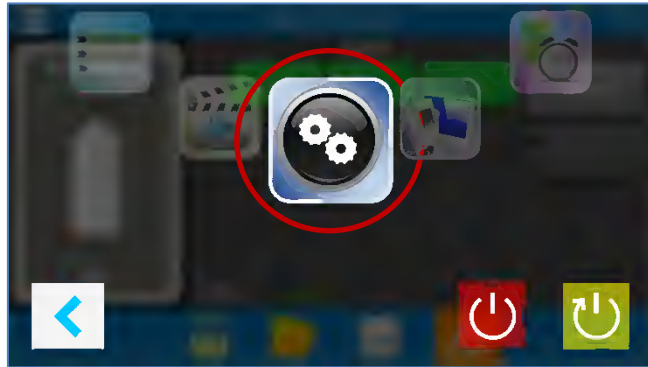

Select  and enable the ISI.

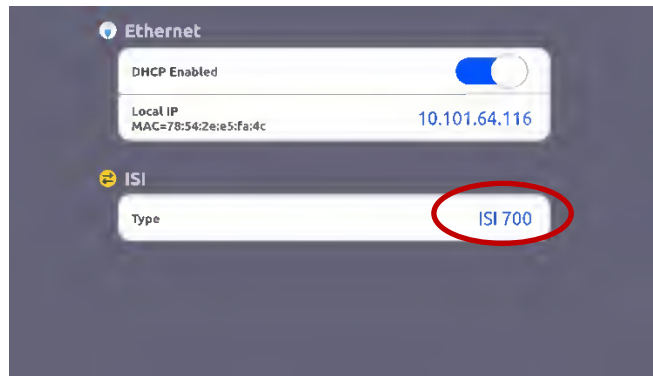

On the protocol screen the following icon should be displayed, indicating that the DC200 module is connected to the RCU.

NOTE: If the DC200 module is disconnected from the RCU and ISI is enabled in the options, the icon on the

protocol screen will change as follows 

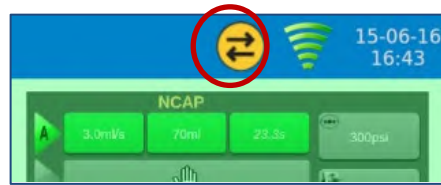

Note: The ISI status icon described above does not and cannot indicate if the scanner is connected to the DC200 module correctly. The only method to check if the scanner is interfaced to the DC200 correctly is to try and initiate an injection.

5.11.3. Inject or Scan Delay

The injector can start the injection before the scanner (scan delay), or the scanner can start the scan before the injection (inject delay).

1. Follow the scanner manufacturer’s instructions for enabling ISI.
2. Program the scanner.
3. Program the injection protocol into the injector. Once the protocol has been programmed, press the ARM button on the injector head or the RCU.
4. Check the fluid pathway for air. Once any air has been purged, press the Check For Air button on the injector head or the RCU
5. Press the scan/inject delay button.



6. Set the value of the delay from the keypad or slider. The delay can be set between 1 – 99 seconds.
7. Toggle between either

- a. Scan Delay 
- b. Inject Delay 

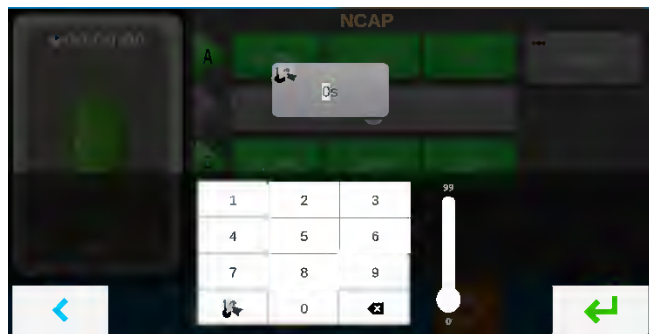

8. Initiate the injection by:
 - a. Scan Delay - pressing the inject button on the RCU, the injector head or infrared control.
 - b. Inject Delay - pressing the inject button on the RCU.

Note: When using an inject delay, injections should be started and stopped on the RCU. Do **NOT** start and stop injections at the injector head, or by using the infrared remote control.

9. Press the back button to terminate the procedure with the scanner.

5.12. [Optional] Protocol Assistance Tool (PAT)

This option can only be enabled by an Imaxeon service or sales representative.

The PAT application provides the user with suggested weight based injection protocols for a range of common CT examinations. It is available only with the optional Remote Control Unit RCU.

The PAT is intended to be used as a guide. It is not intended to replace clinical experience and judgment. The underlying parameters are based on current, published clinical dosage rates and techniques. It is the responsibility of the User to assess the patient's clinical presentation before proceeding with any contrast media injection protocol.

To access PAT, select the wand icon  from the Action menu



Select the *Type* of examination:

- ◆ *Routine* for chest, parenchymal and portal venous applications.
- ◆ *CTA* for arterial imaging.
 - ◆ [Single Only] There will not be a saline flush if CTA is selected.

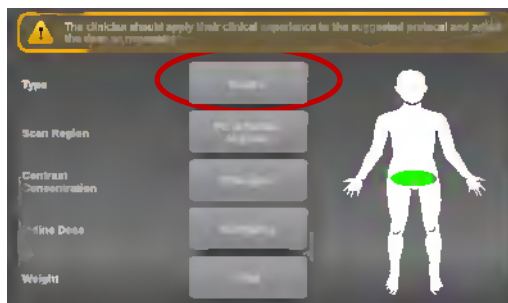

Next select the *Area* for examination.

PAT lists a number of common scanning regions depending upon the *Type* selection.

Toggle through the selection to find the most appropriate *Area*.

The Patient icon graphically represents the *Area* selected. The patient body icon can also be pressed directly to select the area.

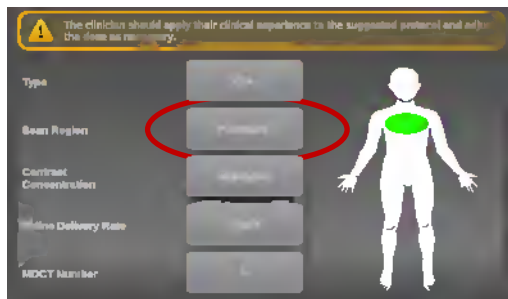

Select *Weight* and enter the patient's weight in kg using the numeric key pad.

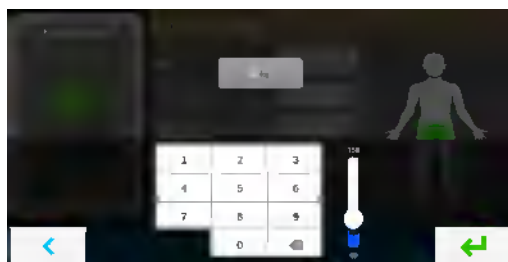

Select *Contrast Concentration* and enter the contrast media concentration in mg/I/ml.

A specific concentration can be added by selecting *Other* and entering the value via the keyboard.

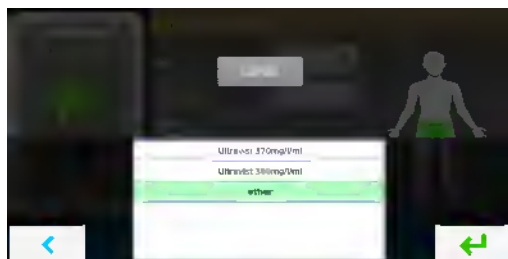

For CTA Type protocols, select *MDCT Number* and select the scanner multi detector slice number from the available options: 4, 16, 64 & 128 MDCT.

Note, this parameter is not available for Routine type protocols as it is not required to calculate contrast media dosing.



Once all of the parameters are entered, select the green tick to generate a suggested protocol .

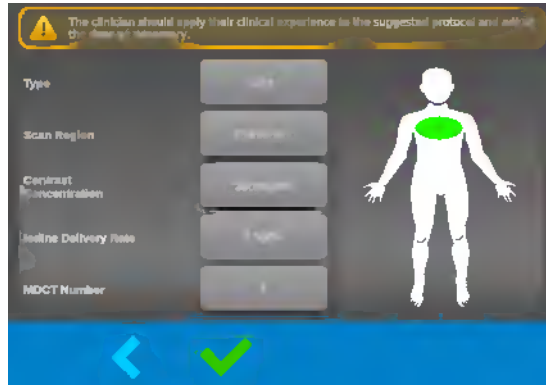

Or select the back arrow to exit .

The generated protocol is displayed with the PAT icon  to alert the user this is a suggested PAT protocol.

Any parameter of PAT generated protocol can be adjusted if required. If a parameter is adjusted, the PAT icon will disappear to indicate the protocol has changed from the original PAT suggestion.

Once the protocol is set, follow the normal safety check and arming procedure to complete the normal injection process.



6. Cleaning and Maintenance

6.1. General Cleaning Procedures

The injector should be switched off and disconnected from the mains supply before cleaning. The covers and external parts of the injector should be cleaned using warm soapy water and a soft cloth. Do not use abrasive cleaning aids, solvents or alcohol wipes.

X-Ray contrast tends to dry quite hard and hence should be wiped off as soon as possible.

Should the syringe piston engaging mechanism may become coated in dried and hardened contrast agent over time, clean as follows:



Press  with no syringe mounted in the bayonet fitting. The piston will extend fully and stop.

With a clean, warm, damp (not wet) cloth, wipe off dried contrast in and around the piston head.



6.1.1. [RCU models] Cleaning the RCU

Clean the RCU tablet with a dry cloth. Do not allow water or cleaning fluid to enter the RCU tablet enclosure.

6.2. Battery Maintenance

6.2.1. Injector Batteries



Warning: The injector batteries should be replaced only by suitably qualified service technicians. Replacement should not be attempted by users or their (untrained) service personnel.

The batteries should be checked at each annual preventive maintenance event for signs of enclosure warping or content leakage.

Expected useful battery life is 2-4 years. If performance noticeably decreases, please contact your service representative for a replacement battery. Do not use substitute batteries.

The reorder code for injector batteries is HB0013.

6.2.2. Remote Control Batteries

The battery in the remote control can be changed by users. When the battery in the remote control is running low, the red LED will illuminate to warn the user that the battery should be changed. If the remote does not work and no LEDs illuminate when either button is pressed, then the battery is fully discharged and should be replaced immediately.

The battery is replaced by loosening the four screws on the bottom of the unit and removing the bottom half of the remote control enclosure. Disconnect the old battery and fit the replacement battery into the same location. Do not over-tighten the screws when re-assembling the remote control. Depending on usage, the expected useful battery life is 12 months.

If the remote control will not be used for more than two weeks, the battery should be removed from the remote control.

The reorder code for the battery in the remote control is HB0001.

6.3. Recommended Regular Check Procedure

6.3.1. Monthly

Once a month, the entire injector should be thoroughly inspected and cleaned and an operational checkout procedure should be performed. Refer to Section 6.3.3 for the checkout procedure.

6.3.2. Annual Check



WARNING

A complete injector calibration and performance checkout should be carried out once a year by an authorised Imaxeon Service Representative. Failure to do so may result in patient or operator injury. Contact IMAXEON Service or your local Imaxeon dealer for complete details.

These annual programs ensure **patient safety** by maintaining accuracy and reliability, and can also extend the life of the injector. Refer to Section 2.8 of this manual for address, fax and telephone information.

Every twelve months, or more often, as required by local authorities, an electrical leakage and ground continuity check should be performed.

Note: Failures which occur due to lack of proper maintenance will not be covered under warranty.

6.3.3. Operator Checkout Procedure

The following checkout procedures test the major functions of the injector and should be completed before using the injector for the first time or as a monthly routine preventive maintenance program. If a problem or a calibration error is suspected, use this procedure for troubleshooting before contacting IMAXEON Service.

Note: After performing this procedure before using the injector for the first time, the injector warranty registration card should be completed, noting the checkout has been performed, and returned to Imaxeon.

Certain steps in this procedure require that multiple observations be made during the test. Read through each step for complete understanding.

If problems arise while going through these procedures, stop and do not use the injector. Record any messages that are displayed. Contact your local Imaxeon Service Representative.

Checkout Procedure

1. Examine the injector for signs of damage or wear.
2. Disconnect the injector from the mains supply by removing the IEC mains connector from the base of the unit.
3. With the injector off, disengage the circuit breaker marked CB on the base of the unit. Reengage the circuit breaker noting the physical movement of the lever. Feel for any sign of difficulty in moving the CB lever.
4. Connect an IEC power cord and connect to the mains supply.
5. Turn the mains rocker switch on the base to the ON position
6. The adjacent LED on the base of the unit will display green.
7. Press the ON switch on the injector head. The display should now turn on and the LED on the head will turn green.
8. The screen display should be bright and clear when viewed front on.
9. Fit a new syringe.
10. Select the “?” button and allow the injector to find the syringe plunger
11. The injector should purge the air from the syringe automatically.
12. Using the manual fill control, touch the screen in the arrowed areas and observe movement of the piston in or out depending on chosen directions.
13. Fill a syringe with an amount of water, say 120mL.
14. Press .
15. Program a routine protocol:

Volume	= 100mL
Flow	= 5mL/s
Pressure	= 300 psi
16. Use a measuring cylinder or similar known volume container marked to 100mL (± 2 mL) volume.
17. Inject 100mL volume and observe the inject time to be 20 seconds (± 1 second) and the measured volume is 100mL (± 2 mL).
18. Check the injection review screen displays an inject time of 20 seconds (± 1 second) and a delivered volume of 100mL (± 2 mL).
19. Perform the 100mL injection again, but occlude the tubing by kinking or blocking the tube. Ensure that the injection halts with an over-pressure or stall alarm.

20. Switch off the mains rocker switch on the base of the unit. Ensure that the battery symbol is displayed at the top of the injector display screen.

6.4. Disposing of the Injector

The symbol shown below indicates the product must not be disposed of with other waste. Instead, it is the user's responsibility to dispose of the product by handing it over to a designated collection point for the recycling of waste electrical and electronic equipment. Contact your Imaxeon service representative for further details.



WARNING

The battery contains no mercury or mercury compounds. However, it does contain the following hazardous materials:

- Lead 48~53 wt%
- Lead Oxide 23~26%
- Lead Sulphate < 1. wt%
- Electrolyte – Sulphuric Acid 7~10 wt%

Please dispose of this pack within environmental pollution guidelines depending on your local regulations.

7. Trouble-shooting

7.1. Fault Finding Guide

Symptoms	Actions
Injector does not power up	<ol style="list-style-type: none"> 1.Check that circuit breaker is pressed in 2.Connect AC mains cable 3.Replace batteries 4.Contact Imaxeon Service
Injection stops mid-way through an injection	<ol style="list-style-type: none"> 1.Check for kink in giving set tubing 2.Check for cannula placement and possible arterial occlusion from patient arm position 3.Check battery health 4.Contact Imaxeon Service
Piston does not disengage from syringe plunger properly when retracting after injection	<ol style="list-style-type: none"> 1.Remove syringe manually 2.Sensor does not work if used in bright sunlight or if foreign object (such as sticky tape) is affixed to syringe near plunger
Spurious over-pressures and washed out images (due to reduced contrast flow).	Check for dried contrast around piston on injector head particularly where the piston passes through the O-ring. Clean all dried contrast from this location.
	Red battery indicator - Connect injector to mains power supply and recharge battery.
Insufficient Volume	There is insufficient volume in the syringe to deliver the requested protocol. Refill the syringe.
Syringe Plunger Not Found	Remove the syringe and re-engage as shown in Section 5.2.3 of this manual
Adaptive Flow Active	Assess the patient injection site and tubing for partial occlusions and adjust tubing or patient to reduce any occlusion.
Battery failure (not charging)	Order a replacement battery from your authorised service agent. You may continue to use the injector on mains supply until a replacement battery is installed.
Over Pressure	Check tubing and cannula for kinks or occlusions.
Stalled (Adaptive flow reached zero flow)	
Syringe Lost error	Syringe removed or not detected while in Inject mode. Press the Back button to go to the Review screen

7.1.1. [RCU Models] Trouble-Shooting

Symptoms	Actions
Unit will not connect to injector	Select a different Wireless ID on both the RCU and injector system and try to connect again.
RCU will not turn on	Check the power supply is connected to the RCU.
Loading/Saving Protocols Fails	Check that a formatted USB memory device is inserted into the RCU.
Wireless connection is Intermittent	Ensure that there are no other Salient RCU devices within range using the same Wireless ID
“System Clock Error” on RCU bootup.	The rechargeable backup battery for the system clock is flat. Charge the RCU for several hours before rebooting. In general, the RCU should be operated while on charger.

7.2. Error Messages

Alarms and error messages are indicated by the status bar at the top of the screen changing colour to red or yellow. Press on the status bar to view the current alarm condition.

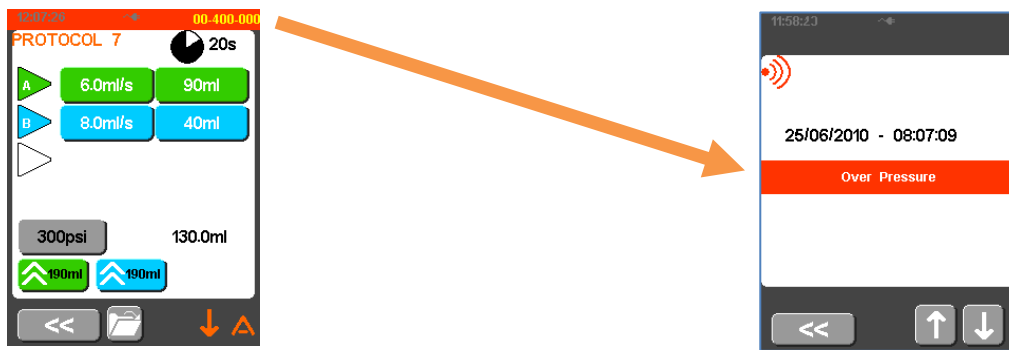

If the error is any other than that described in Section 7.1, remove injector from use and call your authorised service agent.

8. Specifications

8.1. Dimensions

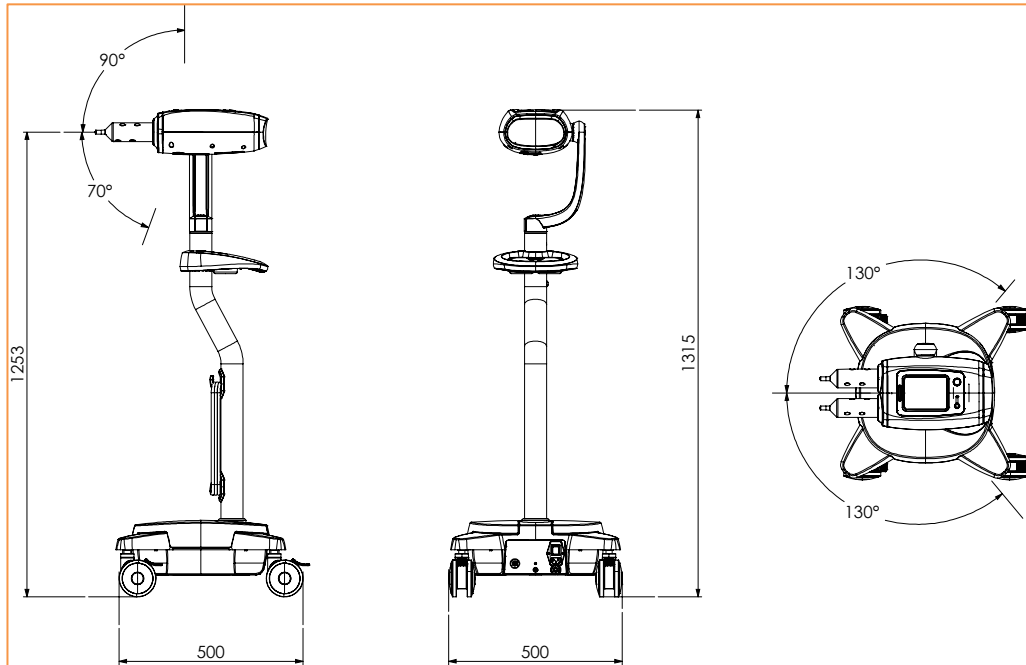

Model: DC009D, DC009DW – Dual

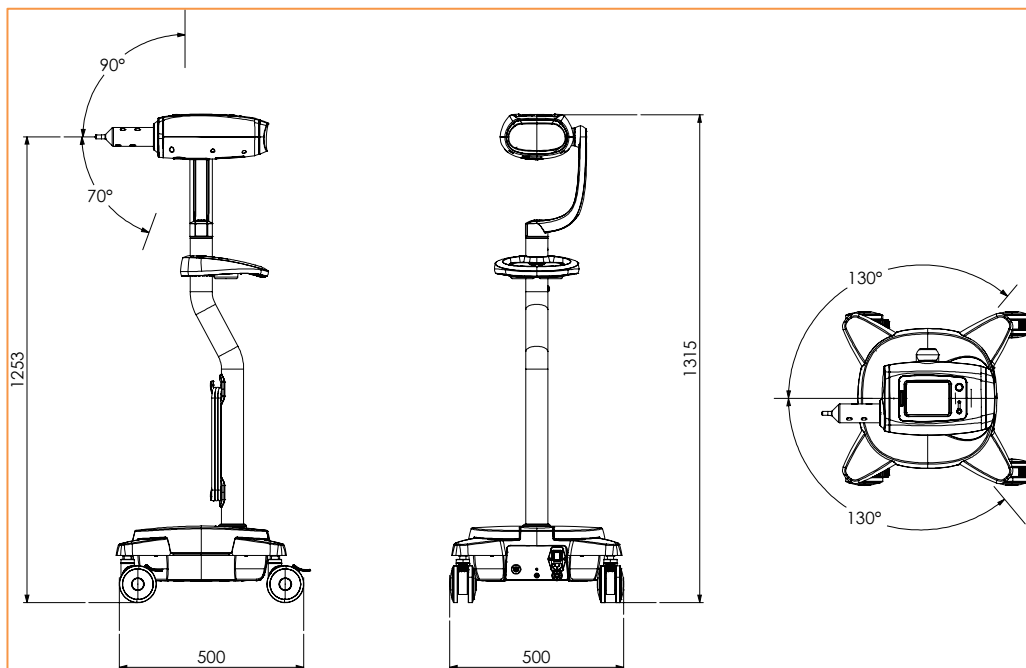

Model: DC009S, DC009SW – Single

8.2. Mechanical

Weight	22.9kg (Single) 25.5 kg (Dual)
Height	1315 mm
Floor Area	500mm x 500mm
No of Wheels	4, locking
Type of Wheel	Rubber Castor, ball bearing race
Construction Materials	Flame retardant ABS panels, Aluminium, Steel
Operating Noise Level	< 95 dBA

8.2.1. [RCU Tablet] Mechanical

Weight	1kg
Dimensions	296(W) x 217(H) x 24.1(D) mm

8.2.2. [DC200] Mechanical

Weight	0.5 kg
Dimensions	120mm x 60mm x 30mm

8.3. Functional

Max Pressure Limit	300 psi
Syringe Mounts	Two (contrast and saline) [Dual Only] One (contrast) [Single Only]
Display pressure accuracy	+/- 50psi
(User Selectable) Set Pressure Limit	100 to 300 psi in 1 psi increments
Injected flow rate accuracy	+/- 5%
Max Flow Rate	10 ml/s
Programmable Flow Rate	User-settable in 0.1 ml/s increments from 0.1 to 10ml/s
Maximum Deliverable Volume	190 ml
Displayed volume accuracy	+/- 1% or 0.5ml whichever is greater
Programmable Volume	User-settable in 1ml increments from 1 to 190ml
Manual Fill rate	0.1 to 10 ml/s
Auto Fill rate	0.1 to 10 ml/s
Multistage Injection	Up to 6 phases
Pause Phase Range	1 to 900 seconds in 0.1 second increments

8.4. Controls

Pedestal	Line power ON/OFF, double pole switch IEC power inlet, double fused
Circuit Breaker	3A max
Injector Head Touchscreen	Fill control Protocol Programming
Injector buttons	Power on/off Arm
Remote control	Start/stop injection
Hand-switch or footswitch	Start/stop injection

8.5. Environmental

Temperature – transport/storage	-20°C to +60°C
Temperature – operation	+10°C to +40°C
Humidity – transport/storage	10% to 95% RH, non-condensing
Humidity – operation	20% to 80% RH
Barometric Pressure – transport/storage	48kPa to 110kPa
Barometric Pressure - operation	70kPa to 106kPa

8.5.1. [RCU Tablet] Environmental

Temperature – storage and transportation	-20°C to 50°C
Relative humidity – storage and transportation	20% to 93% (40°C)
Atmospheric pressure	86kPa to 106kPa
Temperature - operation	0°C to 35°C
Relative humidity – operation	35% to 80%

8.5.2. [DC200] Environmental

Temperature – transport/storage	-20°C to +60°C
Temperature – operation	+10°C to +40°C
Humidity – transport/storage	10% to 95% RH, non-condensing
Humidity – operation	20% to 80% RH
Barometric Pressure – transport/storage	48kPa to 110kPa
Barometric Pressure - operation	70kPa to 106kPa

8.6. Electrical

Line Voltage	100-230 V~ ±10%
Line frequency	50/60 Hz
Phase	Single
Charging	AC only
Operating	Batteries or AC
Max Current Consumption, Operating	2.0A peak
Max Current Consumption, Standby	0.5A or less
Consumption, Charging from mains	1A maximum
Current Surge (inlet fuse) Rating	2A maximum
Battery Voltage	12VDC
Battery type	Imaxeon 12 V7.2Ah Lead Acid
Battery Hazardous Material Content	Lead: 48~53 wt% Lead Oxide: 23~26% Lead Sulphate: < 1. wt% Electrolyte – Sulphuric Acid: 7~10 wt% Contains no mercury or mercury compounds.
No. of Batteries	2
Recharge time (for 25 injections)	8 hours
Battery Service Life	2 years
Contrast Heat Maintainer operation	Auto detects heat maintainer plugged in.
Contrast Heat Maintainer – rating	5W
Contrast Heat Maintainer – temperature range	37±4°C
Category AP/APG	Not Applicable

8.6.1. [RCU Tablet] Electrical

AC Adapter	Wide mode AC power supply 100 – 240VAC 1.5A 50 – 60 Hz 19V 65W DC to tablet
Wireless	IEEE 802.11 b/g/n Injector module Frequency Range: 2412.0 – 2462.0 MHz Output Power: 0.00865 W RCU Tablet Frequency Range: 2412.0 – 2462.0 MHz

8.7. Connectors

Head Cable	26-way D sub-miniature
Hand/Foot Switch	Circular, locking. 3 pin XLR
Line Power	IEC 60320-C14
Equipotential Point	MC POAG-S6 SERIES
Syringe Heater	4 pin Mini-DIN

8.8. IEC 60601-1 Classifications

The Injector is classified as follows:

- ◆ Class 1 equipment with Type BF applied parts.
- ◆ Internally Powered Equipment
- ◆ IPX0 (Injector and hand-switch) Clause 6.3 of IEC60601-1: 2005 (Injector head)
- ◆ IP68 (footswitch)
- ◆ Continuous Operation
- ◆ Not suitable for use in the presence of flammable anaesthetic mixtures with air or oxygen or nitrous oxide

8.9. Ground Continuity

The resistance from the earth ground connector at the plug-end of the AC power cord to any grounded exposed metal is less than 0.2Ω.

8.10. RoHS Statement

This injector meets the Directive 2002/95/EC of the European Parliament and of the Council of 27 January 2003 on the restriction of the use of certain hazardous substances in electrical and electronic equipment (RoHS). The injector, with the exception of the battery, does not contain any of the following banned substances.

- ◆ Mercury
- ◆ Hexavalent Chromium
- ◆ Cadmium
- ◆ Polybrominated Biphenyls
- ◆ Polybrominated Diphenyl Ether
- ◆ Pentabromodiphenyl ether (PentaBDE)
- ◆ Octabromodiphenyl ether (OctaBDE)
- ◆ Decabromodiphenyl ether (DecaBDE)

Refer to Section 6.4 for details of the hazardous material contained in the battery.

8.11. IEC60601-1-2:2014 (4th Ed) Compliance

8.11.1. Electromagnetic Emissions

Guidance and manufacturer's declaration – electromagnetic emissions		
The injector is suitable for use in the electromagnetic environment specified below. The customer or the user of the injector must ensure that it is used in such an environment.		
Emissions test	Compliance	Electromagnetic environment – guidance
RF emissions CISPR 11	Group 1	The injector uses RF energy only for its internal function. Therefore, its RF emissions are very low and are not likely to cause any interference in nearby electronic equipment.
RF emissions CISPR 11	Class B	The injector is suitable for use in all establishments, including domestic establishments and those directly connected to the public low-voltage power supply network that supplies buildings used for domestic purposes.
Harmonic emissions IEC 61000-3-2	Class A	
Voltage fluctuations IEC 61000-3-3	Complies	

8.11.2. Electromagnetic Immunity

Guidance and manufacturer's declaration – electromagnetic immunity				
The injector is suitable for use in the electromagnetic environment specified below. The customer or the user of the injector must ensure that it is used in such an environment.				
Immunity test	IEC 60601-1-2 test compliance level		Electromagnetic environment – guidance	
Electrostatic discharge (ESD) IEC61000-4-2	± 8 kV contact ± 2 kV, ± 4 kV, ± 8 kV, ± 15 kV air		Floors should be wood, concrete or ceramic tile. If floors are covered with synthetic material, the relative humidity should be at least 30%.	
Electrical fast transient/burst IEC 61000-4-4	± 2 kV for power supply lines ± 1 kV for input/output lines		Mains power quality should be that of a typical commercial or hospital environment.	
Surge IEC 61000-4-5	± 0.5 kV, ± 1 kV Line-to-line ± 0.5 kV, ± 1 kV, ± 2 kV Line-to-ground		Mains power quality should be that of a typical commercial or hospital environment.	
Voltage dips IEC 61000-4-11	<i>Voltage test level % UT</i>	<i>Phase</i>	<i>Duration cycles</i>	
	0	0°, 45°, 90°, 135°, 180°, 225°, 270°, 315°		0.5
	0	0°		1
Voltage interruptions IEC 61000-4-11	<i>Voltage test level % UT</i>	<i>Phase</i>	<i>Duration cycles</i>	
	0	0°		250
Power frequency (50/60 Hz) magnetic field IEC 61000-4-8	30 A/m at 50Hz		Power frequency magnetic fields should be at levels characteristic of a typical location in a typical commercial or hospital environment.	
Note: U_T is the AC mains voltage prior to application of the test level.				

Guidance and manufacturer's declaration – electromagnetic immunity
The injector is suitable for use in the electromagnetic environment specified below. The customer or the user of the MEDRAD® Salient contrast injector must ensure that it is used in such an environment.

Immunity test	IEC 60601-1-2 test compliance level	Electromagnetic environment guidance
		<p>Portable and mobile RF communication equipment should be used no closer to any part of the Salient contrast injector than the recommended separation distance calculated from the equation applicable to the frequency of the transmitter.</p> <p>Recommended separation distance:</p>
Conducted RF IEC 61000-4-6	3 Vrms at 1kHz 80% AM 150 kHz to 80 MHz	$d = 1.2\sqrt{P}$
Radiated RF IEC 61000-4-3	3 V/m at 1kHz 80% AM 80 MHz to 2.7GHz	$d = 1.2\sqrt{P}$ 80 MHz to 800 MHz $d = 2.3\sqrt{P}$ 800 MHz to 2.7GHz
	Proximity Fields 385 – 5785 MHz, 9 – 27 V/m	<p>where P is the maximum output power rating of the transmitter in watts (W) according to the transmitter manufacturer and d is the recommended separation distance in metres (m).</p> <p>Field strengths from fixed RF transmitters, as determined by an electromagnetic site survey,^a should be less than the compliance level in each frequency range.^b</p> <p>Interference may occur in the vicinity of equipment marked with this symbol:</p> 
NOTE 1	At 80 MHz and 800 MHz, the higher frequency range applies.	
NOTE 2	These guidelines may not apply in all situations. Electromagnetic propagation is affected by absorption and reflection from structures, objects and people.	
^a	Field strengths from fixed transmitters, such as base stations for radio (cellular/cordless) telephones and land mobile radios, amateur radio, AM and FM radio broadcast and TV broadcast cannot be predicted theoretically with accuracy. To assess the electromagnetic environment due to fixed RF transmitters, an electromagnetic site survey should be considered. If the measured field strength in the location in which the injector is used exceeds the applicable RF compliance level above, the injector should be observed to verify normal operation. If abnormal performance is observed, additional measures may be necessary, such as reorienting or relocating the injector.	
^b	Over the frequency range 150 kHz to 80 MHz, field strengths should be less than 3 V/m.	

8.11.3. Recommended separation distances from portable and mobile RF communications equipment and the injector

Recommended separation distances from portable and mobile RF communications equipment and the injector			
The injector is intended for use in an electromagnetic environment in which radiated RF disturbances are controlled. The customer or the user of the injector can help prevent electromagnetic interference by maintaining a minimum distance between portable and mobile RF communications equipment (transmitters) and the injector as recommended below, according to the maximum output power of the communications equipment.			
Rated maximum output power of transmitter W	Separation distance according to frequency of transmitter m		
	150 kHz to 80 MHz $d = 1.2\sqrt{P}$	80 MHz to 800 MHz $d = 1.2\sqrt{P}$	800 MHz to 2.7 GHz $d = 2.3\sqrt{P}$
0.01	0.1	0.1	0.2
0.1	0.4	0.4	0.7
1	1.3	1.3	2.3
10	3.8	3.8	7.3
100	12.0	12.0	23.0

For transmitters rated at a maximum output power not listed above, the recommended separation distance d in metres (m) can be estimated using the equation applicable to the frequency of the transmitter, where P is the maximum output power rating of the transmitter in watts (W) according to the transmitter manufacturer.

NOTE 1: At 80 MHz and 800 MHz, the separation distance for the higher frequency range applies.

NOTE 2: These guidelines may not apply in all situations. Electromagnetic propagation is affected by absorption and reflection from structures, objects and people.

8.12. Models

Model Number	Description
DC009S	MEDRAD® Salient Contrast Injector Single
DC009D	MEDRAD® Salient Contrast Injector Dual
DC009SW	MEDRAD® Salient Contrast Injector Single with Wireless RCU
DC009DW	MEDRAD® Salient Contrast Injector Dual with Wireless RCU

8.13. Accessories

	Accessory (shaded options are included standard with each injector)	Part number
1.	Power Cord	WP0023 (AU) WP0020 (BR) WP0021 (JP) WP0016 (EU) WP0015 (CH) WP0019 (CN) WP0022 (IT) WP0024 (KR & EU) WP0009 (US, COL, PE) WP0025 (UK) WP0033 (JP/US)
2.	190 ml Syringe with quick fill tube (QFT) – tray (box of 50)	ZY6320
3.	190 ml Syringe with spike – tray (box of 50)	ZY6321
4.	190 ml Syringe with quick fill tube (QFT) – pouch (box of 50)	ZY6322
5.	190 ml Syringe with spike – pouch (box of 50)	ZY6323
6.	190 ml Syringe with spike, 150 cm connecting tube (box of 50)	ZY6324
7.	190 ml Syringe with quick fill tube (QFT), 150 cm connecting tube (box of 50)	ZY6325
8.	150 cm Extension tube single (box of 50)	ZY5151
9.	150 cm Extension tube T-connector (box of 50)	ZY5152
10.	Heat Maintainer (1x for all systems)	DC022
11.	Hand-switch	SF0005
12.	Footswitch	SF0004
13.	Remote Control	VP021
14.	Battery (2 required)	HB0013
15.	Off-line syringe loader	MDL001
16.	DC200 Scanner Interface Box	DC200
17.	IV holder	DC039
18.	Wi-Fi Extender (with DC009SW and DC009DW)	DC121

Operator Manual	MN040010 English
	MN040002 Chinese
	MN040003 French
	MN040004 Italian
	MN040005 German
	MN040009 Spanish
	MN040016 Russian
	MN040017 Portuguese
	MN040018 Greek
	MN040019 Hungarian
	MN040020 Croatian
	MN040021 Czech
	MN040022 Danish
	MN040023 Dutch
	MN040024 Korean
	MN040025 Polish
	MN040026 Romanian
	MN040027 Slovak
	MN040028 Slovenian
	MN040029 Swedish
	MN040030 Turkish
	MN040032 Bulgarian
	MN040035 Serbian
	MN040066 Latvian
	MN040067 Lithuanian
	MN040068 Finnish
	MN040069 Norwegian
	MN040081 Arabic
	MN040087 Spanish
	MN040088 Brazilian Portuguese
	MN040089 Ukrainian
	MN040090 Kazakh
	MN040091 Estonian
	MN040092 Macedonian
	MN040093 Vietnamese
	MN040083 USB with manuals

8.14. Manufacturer's Software License Information

This product contains software that is subject to the GNU General Public License ("GPL") or GNU Lesser General Public License ("LGPL"). These licenses establish that customers have the right to acquire, modify, and redistribute the source code of said software in accordance with the terms of the GPL or the LGPL.

The source code for the software used in this product is subject to the GPL and LGPL, and is available on the Web. To download, please visit the following website

radiology.bayer.com/contact

8.15. FCC Statement

This equipment has been tested and found to comply with the limits for a Class B digital device, pursuant to Part 15 of the FCC Rules. These limits are designed to provide reasonable protection against harmful interference in a residential installation. This equipment generates, uses and can radiate radio frequency energy and, if not installed and used in accordance with the instructions, may cause harmful interference to radio communications. However, there is no guarantee that interference will not occur in a particular installation. If this equipment does cause harmful interference to radio or television reception, which can be determined by turning the equipment off and on, the user is encourage to try to correct the interference by one or more of the following measures: Reorient or relocate the receiving antenna, Increase the separation between the equipment and receiver, Connect the equipment into an outlet on a circuit different from that to which the receiver is connected, Consult the dealer or an experienced radio/TV technician for help. This equipment should be installed and operated with a minimum distance of 20cm between the radiator and any part of your body.

This device complies with part 15 of the FCC Rules. Operation is subject to the following two conditions: (1) This device may not cause harmful interference, and (2) this device must accept any interference received, including interference that may cause undesired operation.

9. Index

- Accessories, 93
- Adaptive flow, 17, 18, 24, 25, 39, 53
- Air embolization, 6
- Alarms, 18, 53, 64
- anaesthetics, 7
- Arm injector, 16, 17, 36
- Auto Start, 66
- AutoFill, 32
- Battery, 9, 16, 93
 - Maintenance, 78
- BF, Type, 14, 89
- Biological Hazard, 14
- Cannula, 23
- castors, 9
- Cautions, 7
- Chemotherapy, 3
- Circuit breaker, 14
- Cleaning, 77
- Clinical, 23
- Connection to other equipment, 7
- Connectors, 89
- Contact Information, 5
- Contraindications, 3
- Contrast Warmer, 26
- Controls, 87
- Creatinine, 69
- DC200, 71
- Disclaimers, 3
- Disposing
 - Injector, 81
- Drug infusion, 3
- Dual Injector, 3, 12, 26, 30, 31, 34, 35, 40, 41, 86, 93
- Duration, 17
- EC Representative, 5
- Electrical Shock, 14
- Electrical Specifications, 88
- EMC, 3, 7
- Emissions, 3, 90
- EN 60601-1, 3, 4
- EN 60601-1-2, 3
- Environmental Specifications, 87
- Equipotential Connection, 14
- Error Messages, 84
- Filling, 31
 - Auto, 32
 - Manual, 7
- flammable anaesthetics, 7
- Flow rate, 17, 24, 35
 - High, 6
- Footswitch, 15, 93
- Functional, 86
- Fuse, 15
- GFR, 10, 69
- Glomerular filtration rate, 10
- Glomerular Filtration Rate, 69
- Ground Continuity, 89
- Handswitch, 15, 93
- Hand-switch, 15
- heat maintainer, 9
- Heat Maintainer, 6, 26
- Hold, 16, 37
- Imaxeon, 5
- Immunity, 90
- Indicators, 18
- Injecting, 35
- Injector Frame, 53
- Injector Head, 13
- Injector-Initiated Scanning, 74
- Intended Use, 3
- LCD**, 18, 53
- LED**, 18, 53
- Line power, 16
- magnetic fields, 9
- Maintenance, 77
- Manual Fill, 17
- Mechanical, 86
- Multi-phase, 41
- Needle, 23
- Next, 16
- On/off button, 17
- Operator Manual, 94
- Options, 17, 45
- Over Pressure, 25, 83
- Pause, 16
- Pinch hazard, 8
- Post-Injection, 39
- Power Cord, 93
- Pressure, 17, 24
- Pressure limiting, 24
- Previous, 16
- Programming, 41
- Protection Against Electric Shock, 89
- Protective earth, 7
- Protective Earth, 15
- Protocol
 - Download, 69
 - Upload, 69
- Protocols, 41
 - Load, 16
 - Multi-phase, 41
 - Routine, 35
- QFT, 28
- Quick Fill Tube, 28
- RCU, 49
- RCU Edit Phase Type, 62
- RCU History
 - Control, 59
 - Icons, 59
 - Review, 68
- RCU Injection
 - Arming, 55
 - Check for Air, 55
 - Control, 58
 - Progress, 57
 - Start, 56
- RCU Protocol
 - Edit, 60
 - Edit Lock, 61
- Remote control, 18, 37, 78
- Remote Control Unit, 49
- Retract, 16
- Review, 39
- RoHS, 89
- Routine Protocol, 35
- Save As, 16
- Scanner Interface, 71
- Serial number, 3
- Serial Number, 3
- Shock hazard, 8
- Specifications, 85
 - Environmental, 87
- Stall, 8, 83
- Standby Button, 13
- Symbols, 14
- Syringe, 6, 28, 93
 - Disposal, 6
 - Filled, 6
 - Heat Maintainer, 6, 26, 93
 - Indicator, 16
 - Loading, 6

Removing, 34
Reuse, 6
syringe heat maintainer, 9
Time, 17
Trademarks, 3
Trapping hazard, 9
Trouble-shooting, 83
Tube, 28, 34

Under flow rates, 6
Under volume, 6
USB Device, 69
Warnings, 7, 14
WEEE, 9, 14
wheel, 9
Wi-Fi, 49
Wireless Link, 51

© 2019-2020 Bayer. This material may not be reproduced, displayed, modified or distributed without the express prior written consent of Bayer.

Bayer, the Bayer Cross, Imaxeon, MEDRAD FluiDots, MEDRAD Salient, MEDRAD, Salient and FluiDots are trademarks owned by and/or registered to Bayer in the U.S. and/or other countries.

In accordance with data privacy and protection laws in Australia and other countries, all patient data that appear in this document are fictitious. No actual patient information is shown.

Bayer reserves the right to modify the specifications and features described herein or to discontinue any product or service identified in this publication at any time without prior notice or obligation. Please contact your authorized Bayer representative for the most current information.

Imaxeon, Bayer HealthCare and Bayer HealthCare Services. For a full list of Bayer offices and authorized dealers, go to:

<http://www.radiology.bayer.com>

REF MN040010 Rev D



