

# **RADIO TEST REPORT**

## **FCC ID: 2A2W8-594733**

**Product** : Ridepad , GoGasm-Vibrating Balls

**Trade Mark** : N/A

**Model Name** : 5947330000

**Family Model** : 5977750000

**Report No.** : S23031600102001

### **Prepared for**

Orion Versand GmbH & Co.KG

Schaeferweg 14, Flensburg 24941, Germany

### **Prepared by**

Shenzhen NTEK Testing Technology Co., Ltd.

1/F, Building E, Fenda Science Park, Sanwei Community, Xixiang Street  
Bao'an District, Shenzhen 518126 P.R. China

Tel: 400-800-6106,0755-2320 0050 / 2320 0090

Website:<http://www.ntek.org.cn>

TEST RESULT CERTIFICATION

Applicant's name : Orion Versand GmbH & Co.KG
Address : Schaeferweg 14, Flensburg 24941, Germany
Manufacturer's Name : TOPARC TECHNOLOGY (SHENZHEN) CO.,LTD.
Address : 101 And 1-4 Floors Of Workshop No. 23-1 Longteng Road, Baoan Community, Yuanshan Street, Longgang Shenzhen, CHINA

Product description

Product name : Ridepad , GoGasm-Vibrating Balls
Model and/or type reference : 5947330000
Family Model : 5977750000

Standards : FCC Part15.249

Test procedure : ANSI C63.10-2013

This device described above has been tested by NTEK, and the test results show that the equipment under test (EUT) is in compliance with the FCC requirements. And it is applicable only to the tested sample identified in the report.

This report shall not be reproduced except in full, without the written approval of NTEK, this document may be altered or revised by NTEK, personnel only, and shall be noted in the revision of the document.

Test sample number : S230316001001
Date of Test :
Date (s) of performance of tests : Mar 27, 2023 ~ Apr 10, 2023
Date of Issue : 09 May, 2024
Test Result : Pass

Testing Engineer : [Signature]
(Allen Liu)

Authorized Signatory : [Signature]
(Alex Li)

**Table of Contents**

**Page**

<b>1 . SUMMARY OF TEST RESULTS</b>	<b>4</b>
1.1 FACILITIES AND ACCREDITATIONS	5
1.2 LABORATORY ACCREDITATIONS AND LISTINGS	5
1.3 MEASUREMENT UNCERTAINTY	5
<b>2 . GENERAL INFORMATION</b>	<b>6</b>
2.1 GENERAL DESCRIPTION OF EUT	6
2.2 DESCRIPTION OF TEST MODES	8
2.3 BLOCK DIGRAM SHOWING THE CONFIGURATION OF SYSTEM TESTED	9
2.4 DESCRIPTION OF SUPPORT UNITS (CONDUCTED MODE)	10
2.5 EQUIPMENTS LIST FOR ALL TEST ITEMS	11
<b>3 . ANTENNA REQUIREMENT</b>	<b>13</b>
3.1 STANDARD REQUIREMENT	13
3.2 EUT ANTENNA	13
3.3 CONDUCTED EMISSION MEASUREMENT	14
3.3.1 POWER LINE CONDUCTED EMISSION LIMITS	14
3.3.2 TEST PROCEDURE	15
3.3.3 DEVIATION FROM TEST STANDARD	15
3.3.4 TEST SETUP	15
3.2.5 TEST RESULT	16
3.4 RADIATED EMISSION MEASUREMENT	17
3.4.1 RADIATED EMISSION LIMITS	17
3.4.2 TEST PROCEDURE	18
3.4.3 DEVIATION FROM TEST STANDARD	18
3.4.4 TEST RESULTS (BELOW 30MHZ)	20
3.4.5 TEST RESULTS (BELOW 1000 MHZ)	21
3.4.6 TEST RESULTS (ABOVE 1000 MHZ)	23
3.4.7 TEST RESULTS (RESTRICTED BANDS REQUIREMENTS)	29
<b>4. BANDWIDTH TEST</b>	<b>33</b>
4.1 TEST PROCEDURE	33
4.2 DEVIATION FROM STANDARD	33
4.3 TEST SETUP	33
4.4. TEST RESULTS	34

**1. SUMMARY OF TEST RESULTS**

Test procedures according to the technical standards:

<b>FCC Part15, Subpart C (15.249)</b>			
Standard Section	Test Item	Judgment	Remark
15.207	Conducted Emission	N/A	
15.203	Antenna Requirement	Pass	
15.249 15.209	Radiated Spurious Emission	Pass	
15.249b(2)	Frequency Tolerance	N/A	
15.249(a)	Fundamental Measurement	Pass	
15.205	Band Edge Emission	Pass	
15.215	Occupied Bandwidth	Pass	

Note: "N/A" denotes test is not applicable in this Test Report.

**1.1 FACILITIES AND ACCREDITATIONS**

**FACILITIES**

All measurement facilities used to collect the measurement data are located at 1/F, Building E, Fenda Science Park Sanwei, Xixiang, Bao'an District Shenzhen, Guangdong, China

The sites are constructed in conformance with the requirements of ANSI C63.7, ANSI C63.10 and CISPR Publication 22.

**1.2 LABORATORY ACCREDITATIONS AND LISTINGS**

Site Description

CNAS-Lab. : The Certificate Registration Number is L5516.

IC-Registration : The Certificate Registration Number is 9270A.  
CAB identifier:CN0074

FCC- Accredited : Test Firm Registration Number: 463705.  
Designation Number: CN1184

A2LA-Lab. : The Certificate Registration Number is 4298.01  
This laboratory is accredited in accordance with the recognized International Standard ISO/IEC 17025:2005 General requirements for the competence of testing and calibration laboratories.  
This accreditation demonstrates technical competence for a defined scope and the operation of a laboratory quality management system (refer to joint ISO-ILAC-IAF Communiqué dated 8 January 2009).

Name of Firm : Shenzhen NTEK Testing Technology Co., Ltd.

Site Location : 1/F, Building E, Fenda Science Park Sanwei, Xixiang, Bao'an District Shenzhen, Guangdong, China

**1.3 MEASUREMENT UNCERTAINTY**

The reported uncertainty of measurement  $y \pm U$ , where expanded uncertainty U is based on a standard uncertainty multiplied by a coverage factor of  $k=2$ , providing a level of confidence of approximately 95 %.

No.	Item	Uncertainty
1	Conducted Emission Test	$\pm 2.80\text{dB}$
2	RF power, conducted	$\pm 0.16\text{dB}$
3	Spurious emissions, conducted	$\pm 0.21\text{dB}$
4	All emissions, radiated(9kHz~30MHz)	$\pm 2.6\text{dB}$
5	All emissions, radiated(30MHz~1GHz)	$\pm 2.64\text{dB}$
6	All emissions, radiated(1GHz~6GHz)	$\pm 2.40\text{dB}$
7	All emissions, radiated(> 6GHz)	$\pm 2.52\text{dB}$
8	Temperature	$\pm 0.5^\circ\text{C}$
9	Humidity	$\pm 2\%$
10	Occupied bandwidth	$\pm 4.7\text{dB}$

## 2. GENERAL INFORMATION

### 2.1 GENERAL DESCRIPTION OF EUT

Equipment	Ridepad , GoGasm-Vibrating Balls
Trade Mark	N/A
Model Name	5947330000
Family Model	5977750000
Model Difference	All models are the same circuit and RF module, except the model name and the different receivers used.
Product Description	The EUT is a Ridepad , GoGasm-Vibrating Balls
	Operation Frequency: 2407-2459MHz
	Modulation Type: GFSK
	Antenna Designation: PCB Antenna
	Antenna Gain(Peak) 0dBi
	Based on the application, features, or specification exhibited in User's Manual. More details of EUT technical specification, please refer to the User's Manual.
Channel List	Please refer to the Note 2.
Adapter	N/A
Battery	N/A
Power supply	DC 12V from Battery
Hardware version	N/A
Software version	N/A

Note:

1. For a more detailed features description, please refer to the manufacturer's specifications or the User's Manual.

2.

Channel	Frequency(MHz)
01	2407
02	2448
03	2459

3.

Table for Filed Antenna

Ant.	Brand	Model Name	Antenna Type	Connector	Gain (dBi)	NOTE
1	N/A	N/A	PCB antenna	N/A	0	Antenna

Note:The device does not support simultaneous transmission

## 2.2 DESCRIPTION OF TEST MODES

To investigate the maximum EMI emission characteristics generates from EUT, the test system was pre-scanning tested base on the consideration of following EUT operation mode or test configuration mode which possible have effect on EMI emission level. Each of these EUT operation mode(s) or test configuration mode(s) mentioned above was evaluated respectively.

Pretest Mode	Description
Mode 1	CH01
Mode 2	CH02
Mode 3	CH03

For Radiated Spurious Emission	
Pretest Mode	Description
Mode 1	CH01
Mode 2	CH02
Mode 3	CH03

For Conducted Emission	
Final Test Mode	Description
Mode 1	CH01
Mode 2	CH02
Mode 3	CH03

Note:

(1) EUT built-in battery-powered, the battery is new.



### 2.3 BLOCK DIGRAM SHOWING THE CONFIGURATION OF SYSTEM TESTED

For Radiated Test Cases

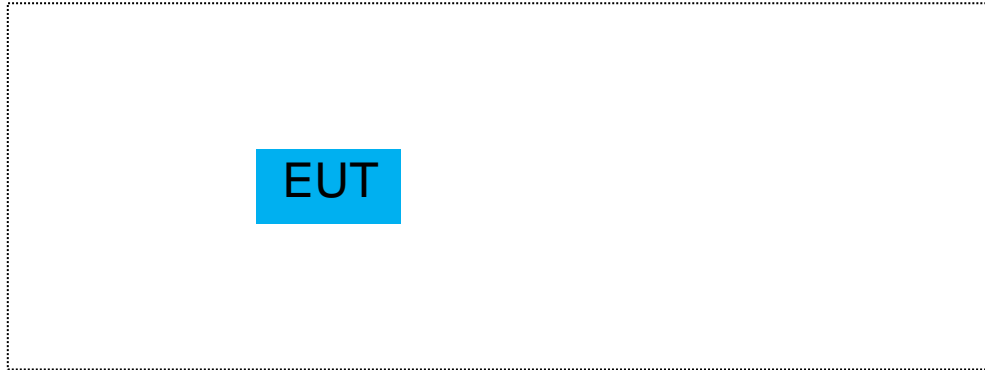

For Conducted Test Cases

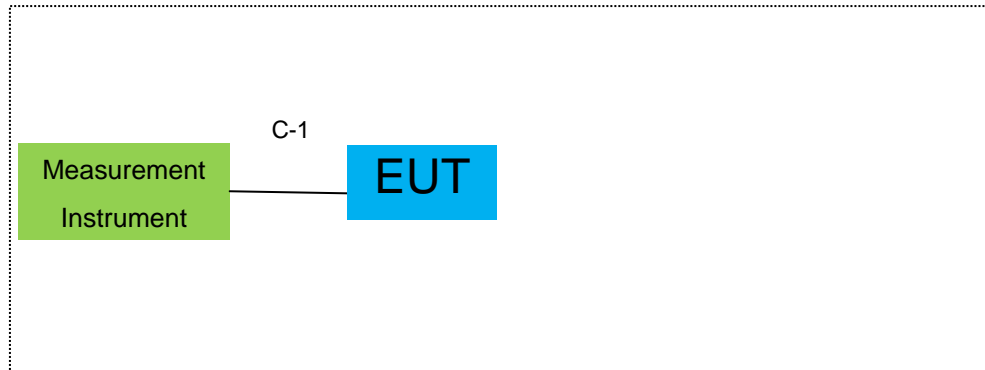

**2.4 DESCRIPTION OF SUPPORT UNITS (CONDUCTED MODE)**

The EUT has been tested as an independent unit together with other necessary accessories or support units. The following support units or accessories were used to form a representative test configuration during the tests.

Item	Equipment	Model/Type No.	Series No.	Note

Item	Cable Type	Shielded Type	Ferrite Core	Length	Note
C-1	RF Cable	NO	NO	0.5m	

Note:

- (1) The support equipment was authorized by Declaration of Confirmation.
- (2) For detachable type I/O cable should be specified the length in cm in 『Length』 column.

## 2.5 EQUIPMENTS LIST FOR ALL TEST ITEMS

### Radiation Test equipment

	Kind of Equipment	Manufacturer	Type No.	Serial No.	Last calibration	Calibrated until	Calibration period
1	Spectrum Analyzer	Agilent	E4407B	MY45108040	2023.03.27	2024.03.26	1 year
2	Spectrum Analyzer	Agilent	N9020A	MY49100060	2022.06.17	2023.06.16	1 year
3	Spectrum Analyzer	R&S	FSV40	101417	2023.03.27	2024.03.26	1 year
4	Test Receiver	R&S	ESPI7	101318	2023.03.27	2024.03.26	1 year
5	Bilog Antenna	TESEQ	CBL6111D	31216	2023.03.27	2024.03.26	1 year
6	50Ω Coaxial Switch	Anritsu	MP59B	6200983705	2020.05.11	2023.05.10	3 year
7	Horn Antenna	EM	EM-AH-10180	2011071402	2023.03.27	2024.03.26	1 year
8	Broadband Horn Antenna	SCHWARZBECK	BBHA 9170	803	2022.11.08	2023.11.07	1 year
9	Amplifier	EMC	EMC051835SE	980246	2022.06.17	2023.06.16	1 year
10	Active Loop Antenna	SCHWARZBECK	FMZB 1519B	055	2022.11.08	2023.11.07	1 year
11	Power Meter	DARE	RPR3006W	15I00041SN084	2022.11.08	2023.11.07	1 year
12	Test Cable (9KHz-30MHz)	N/A	R-01	N/A	2020.05.11	2023.05.10	3 year
13	Test Cable (30MHz-1GHz)	N/A	R-02	N/A	2020.05.11	2023.05.10	3 year
14	High Test Cable(1G-40G Hz)	N/A	R-03	N/A	2022.06.17	2025.06.16	3 year
15	Filter	TRILTHIC	2400MHz	29	2022.11.08	2023.11.07	1 year
16	temporary antenna connector (Note)	NTS	R001	N/A	N/A	N/A	N/A

**Note:**

The temporary antenna connector is soldered on the PCB board in order to perform conducted tests and this temporary antenna connector is listed in the equipment list.

**Conduction Test equipment**

Item	Kind of Equipment	Manufacturer	Type No.	Serial No.	Last calibration	Calibrated until	Calibration period
1	Test Receiver	R&S	ESCI	101160	2023.03.27	2024.03.26	1 year
2	LISN	R&S	ENV216	101313	2023.03.27	2024.03.26	1 year
3	LISN	SCHWARZBECK	NNLK 8129	8129245	2023.03.27	2024.03.26	1 year
4	50Ω Coaxial Switch	ANRITSU CORP	MP59B	6200983704	2020.05.11	2023.05.10	3 year
5	Test Cable (9KHz-30MHz)	N/A	C01	N/A	2020.05.11	2023.05.10	3 year
6	Test Cable (9KHz-30MHz)	N/A	C02	N/A	2020.05.11	2023.05.10	3 year
7	Test Cable (9KHz-30MHz)	N/A	C03	N/A	2020.05.11	2023.05.10	3 year

Note: Each piece of equipment is scheduled for calibration once a year except the Test Cable which is scheduled for calibration every 3 years.

### **3. ANTENNA REQUIREMENT**

#### **3.1 STANDARD REQUIREMENT**

15.203 requirement: For intentional device, according to 15.203: an intentional radiator shall be designed to ensure that no antenna other than that furnished by the responsible party shall be used with the device.

#### **3.2 EUT ANTENNA**

The EUT antenna is permanent attached PCB antenna (Gain: 0dBi). It comply with the standard requirement.

**3.3 CONDUCTED EMISSION MEASUREMENT**

**3.3.1 POWER LINE CONDUCTED EMISSION Limits (Frequency Range 150KHz-30MHz)**

FREQUENCY (MHz)	Class A (dBuV)		Class B (dBuV)		Standard
	Quasi-peak	Average	Quasi-peak	Average	
0.15 -0.5			66 - 56 *	56 - 46 *	CISPR
0.50 -5.0			56.00	46.00	CISPR
5.0 -30.0			60.00	50.00	CISPR

0.15 -0.5			66 - 56 *	56 - 46 *	LP002.
0.50 -5.0			56.00	46.00	LP002.
5.0 -30.0			60.00	50.00	LP002.

Note:

- (1) The tighter limit applies at the band edges.
- (2) The limit of " \* " marked band means the limitation decreases linearly with the logarithm of the frequency in the range.

The following table is the setting of the receiver

Receiver Parameters	Setting
Attenuation	10 dB
Start Frequency	0.15 MHz
Stop Frequency	30 MHz
IF Bandwidth	9 kHz

**3.3.2 TEST PROCEDURE**

- a. The EUT was placed 0.4 meters from the horizontal ground plane with EUT being connected to the power mains through a line impedance stabilization network (LISN). All other support equipments powered from additional LISN(s). The LISN provide 50 Ohm/ 50uH of coupling impedance for the measuring instrument.
- b. Interconnecting cables that hang closer than 40 cm to the ground plane shall be folded back and forth in the center forming a bundle 30 to 40 cm long.
- c. I/O cables that are not connected to a peripheral shall be bundled in the center. The end of the cable may be terminated, if required, using the correct terminating impedance. The overall length shall not exceed 1 m.
- d. LISN at least 80 cm from nearest part of EUT chassis.
- e. For the actual test configuration, please refer to the related Item –EUT Test Photos.

**3.3.3 DEVIATION FROM TEST STANDARD**

No deviation

**3.3.4 TEST SETUP**

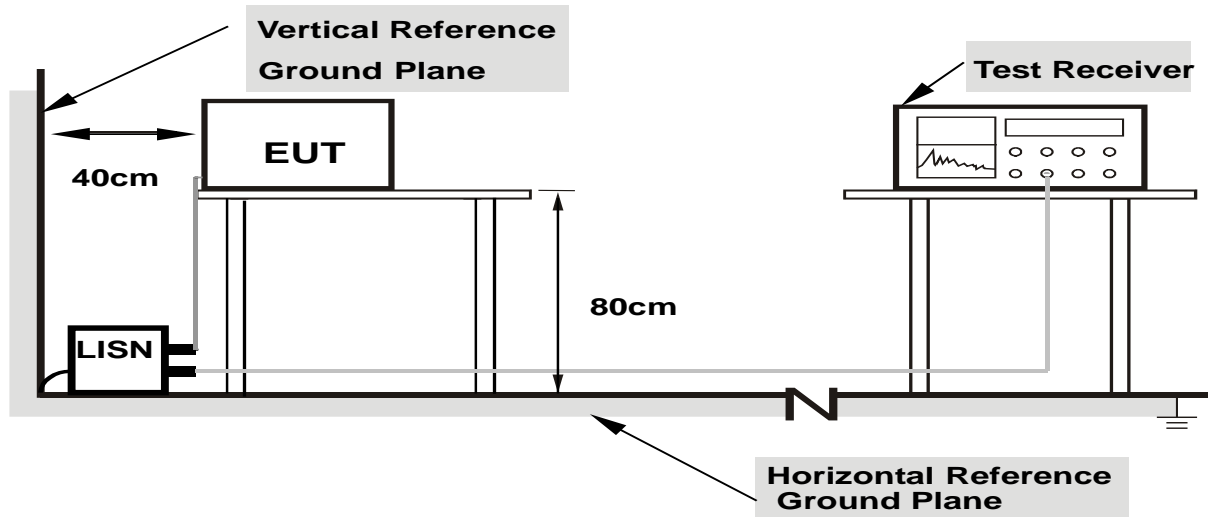

- Note:**
- 1.Support units were connected to second LISN.
  - 2.Both of LISNs (AMN) are 80 cm from EUT and at least 80 from other units and other metal planes

**3.2.5 TEST RESULT**

EUT :	Ridepad , GoGasm-Vibrating Balls	Model Name. :	5947330000
Temperature :	25 °C	Relative Humidity :	55%
Pressure :	1010hPa	Phase :	N/A
Test Voltage :	N/A	Test Mode :	N/A

Note: The EUT is powered by battery, so this item is not applicable



### 3.4 RADIATED EMISSION MEASUREMENT

#### 3.4.1 Radiated Emission Limits ( FCC 15.209 )

Frequencies (MHz)	Field Strength (micorvolts/meter)	Measurement Distance (meters)
0.009~0.490	2400/F(KHz)	300
0.490~1.705	24000/F(KHz)	30
1.705~30.0	30	30
Frequency (MHz)	Limit (dBuV)	
30~88	40	3
88~216	43.5	3
216~960	46	3
960 -10000	54.00	3
902-928	94	3

Note:

- (1) The tighter limit applies at the band edges.
- (2) Emission level (dBuV/m)=20log Emission level (uV/m).
- (3) \*Note: This is the limit for the fundamental frequency.

#### LIMITS OF RADIATED EMISSION MEASUREMENT ( FCC 15.249)

Frequency of Emission (MHz)	Field Strength of fundamental (millivolts /meter)	Field Strength of Harmonics (microvolts/meter)
902-928	50	500

Notes:

- (1) Emissions radiated outside of the specified frequency bands, except for harmonics, shall be attenuated by at least 50 dB below the level of the fundamental or to the general radiated emission limits in Section 15.209, whichever is the lesser attenuation.

Spectrum Parameter	Setting
Attenuation	Auto
Start Frequency	1000 MHz
Stop Frequency	10th carrier harmonic
RB / VB (emission in restricted band)	1MHz / 1MHz for Peak

Receiver Parameter	Setting
Attenuation	Auto
Start ~ Stop Frequency	9kHz~150kHz / RB 200Hz for QP
Start ~ Stop Frequency	150kHz~30MHz / RB 9kHz for QP
Start ~ Stop Frequency	30MHz~1000MHz / RB 120kHz for QP

### 3.4.2 TEST PROCEDURE

- a. The measuring distance of at 3 m shall be used for measurements at frequency up to 1GHz. For frequencies above 1GHz, any suitable measuring distance may be used.
- b. The EUT was placed on the top of a rotating table 0.8 m for below 1GHz and 1.5m for above 1GHz the ground at a 3 meter. The table was rotated 360 degrees to determine the position of the highest radiation.
- c. The height of the equipment or of the substitution antenna shall be 0.8 m for below 1GHz and 1.5m for above 1GHz; the height of the test antenna shall vary between 1 m to 4 m. Both horizontal and vertical polarizations of the antenna are set to make the measurement.
- d. The initial step in collecting conducted emission data is a spectrum analyzer peak detector mode pre-scanning the measurement frequency range. Significant peaks are then marked and then Quasi Peak detector mode re-measured.
- e. If the Peak Mode measured value compliance with and lower than Quasi Peak Mode Limit, the EUT shall be deemed to meet QP Limits and then no additional QP Mode measurement performed.
- f. For the actual test configuration, please refer to the related Item –EUT Test Photos.

Note:

Both horizontal and vertical antenna polarities were tested and performed pretest to three orthogonal axis. The worst case emissions were reported

### 3.4.3 DEVIATION FROM TEST STANDARD

No deviation

(A) Radiated Emission Test-Up Frequency Below 30MHz

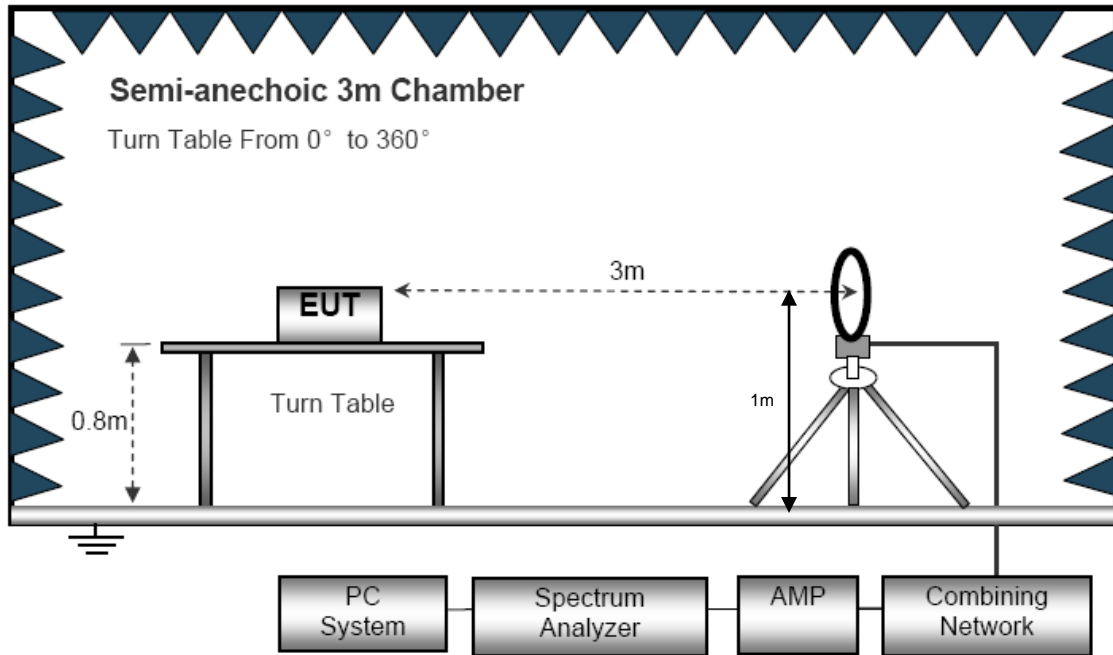

(B) Radiated Emission Test-Up Frequency 30MHz~1GHz

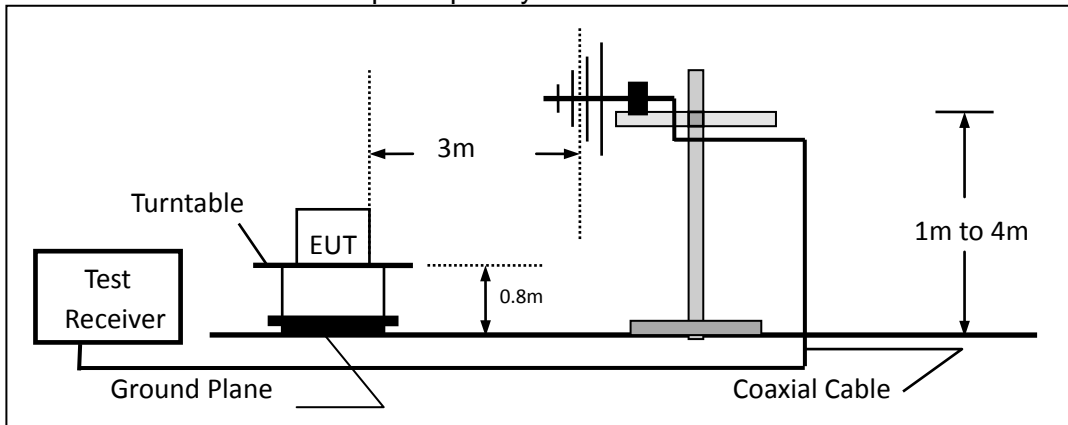

(C) Radiated Emission Test-Up Frequency Above 1GHz

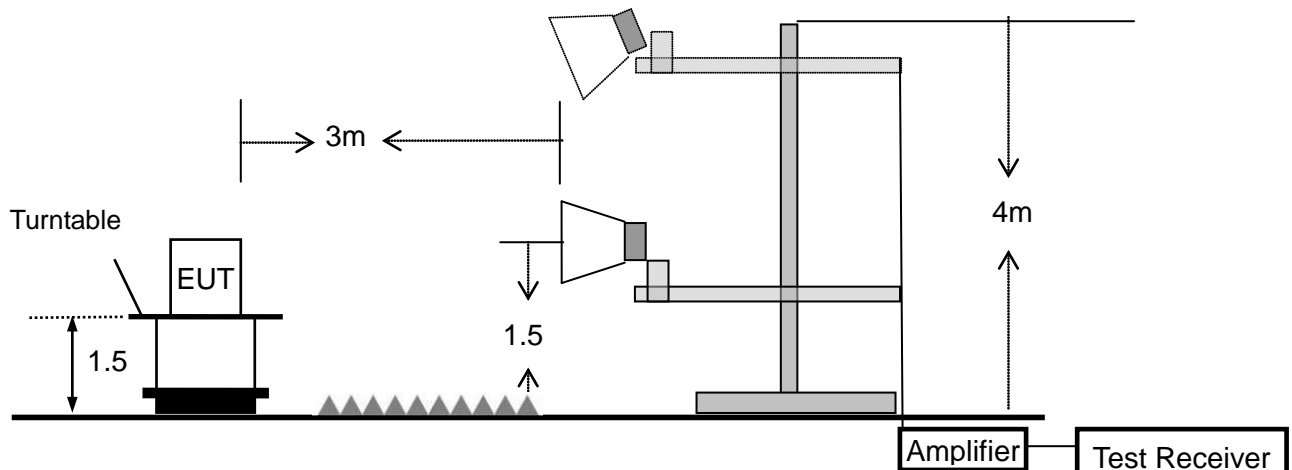

**3.4.4 TEST RESULTS (BELOW 30MHz)**

EUT :	Ridepad , GoGasm-Vibrating Balls	Model Name. :	5947330000
Temperature :	20 °C	Relative Humidity :	48%
Pressure :	1010 hPa	Test Voltage :	DC 12V
Test Mode :	TX	Polarization :	--

Freq. (MHz)	Reading (dBuV/m)	Limit (dBuV/m)	Margin (dB)	State P/F
--	--	--	--	PASS
--	--	--	--	PASS

**NOTE:**

The amplitude of spurious emissions which are attenuated by more than 20dB below the permissible value has no need to be reported.

Distance extrapolation factor =  $20 \log (\text{specific distance}/\text{test distance})$ (dB);

Limit line = specific limits(dBuv) + distance extrapolation factor.

**3.4.5 TEST RESULTS (BELOW 1000 MHz)**

EUT :	Ridepad , GoGasm-Vibrating Balls	Model Name :	5947330000
Temperature :	25 °C	Relative Humidity :	51%
Pressure :	1010 hPa	Test Voltage :	DC 12V
Test Mode :	Mode 1	Polarization :	Vertical

Frequency (MHz)	Meter Reading (dBμV)	Factor (dB)	Emission Level (dBμV/m)	Limits (dBμV/m)	Margin (dB)	Detector Type
30.7454	5.51	26.05	31.56	40.00	-8.44	QP
36.3814	6.66	22.95	29.61	40.00	-10.39	QP
83.8156	6.99	15.91	22.90	40.00	-17.10	QP
174.4241	10.15	17.24	27.39	43.50	-16.11	QP
299.3158	6.66	20.19	26.85	46.00	-19.15	QP
739.6604	10.92	28.67	39.59	46.00	-6.41	QP

Remark:

1. Factor = Antenna Factor + Cable Loss – Pre-amplifier.

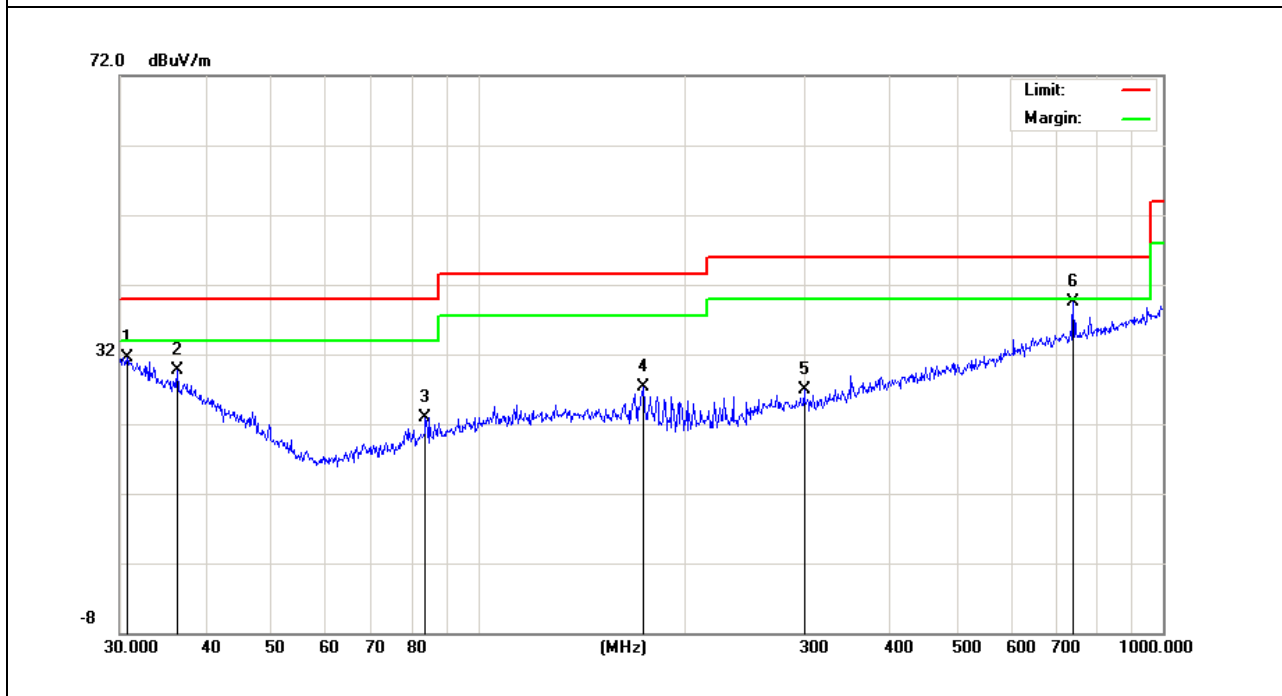

EUT :	Ridepad , GoGasm-Vibrating Balls	Model Name :	5947330000
Temperature :	25 °C	Relative Humidity :	51%
Pressure :	1010 hPa	Test Voltage :	DC 12V
Test Mode :	Mode 1	Polarization :	Horizontal

Frequency (MHz)	Meter Reading (dBµV)	Factor (dB)	Emission Level (dBµV/m)	Limits (dBµV/m)	Margin (dB)	Detector Type
30.3172	6.12	26.29	32.41	40.00	-7.59	QP
63.9828	9.70	12.45	22.15	40.00	-17.85	QP
110.9571	6.23	18.37	24.60	43.50	-18.90	QP
178.1327	8.69	17.04	25.73	43.50	-17.77	QP
201.3930	9.84	16.43	26.27	43.50	-17.23	QP
389.3549	6.39	22.99	29.38	46.00	-16.62	QP

Remark:

1. Factor = Antenna Factor + Cable Loss – Pre-amplifier.

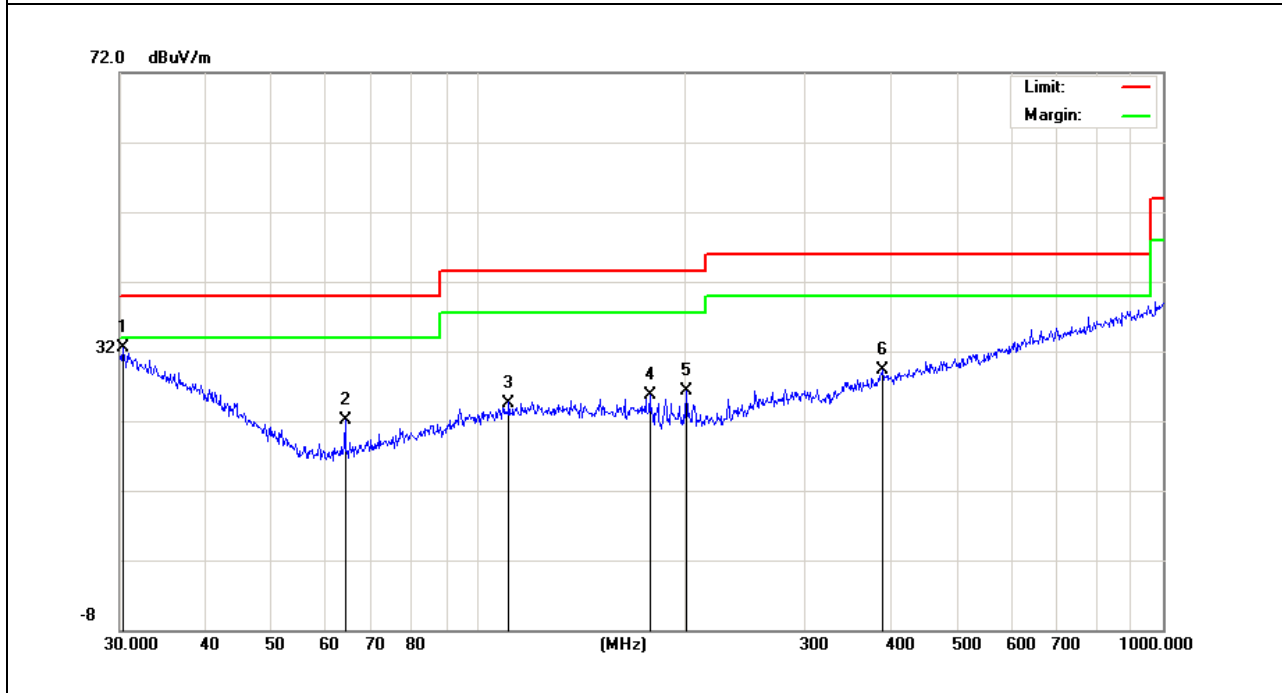

**3.4.6 TEST RESULTS (ABOVE 1000 MHZ)**

EUT :	Ridepad , GoGasm-Vibrating Balls	Model Name :	5947330000
Temperature :	25 °C	Relative Humidity :	51%
Pressure :	1010 hPa	Test Voltage :	DC 12V
Test Mode :	Mode 1-2407	Polarization :	Horizontal

Frequency (MHz)	Meter Reading (dBµV)	Factor (dB)	Emission Level (dBµV/m)	Limits (dBµV/m)	Margin (dB)	Detector Type
2407.000	74.96	10.00	84.96	114.0	-29.04	peak
2407.000	55.30	10.00	65.30	94.00	-28.70	AVG
6661.000	27.58	20.83	48.41	74.00	-25.59	peak
6661.000	17.47	20.83	38.30	54.00	-15.70	AVG
13206.00	24.23	28.52	52.75	74.00	-21.25	peak
13206.00	13.98	28.52	42.50	54.00	-11.50	AVG

Remark:  
Factor = Antenna Factor + Cable Loss – Pre-amplifier.

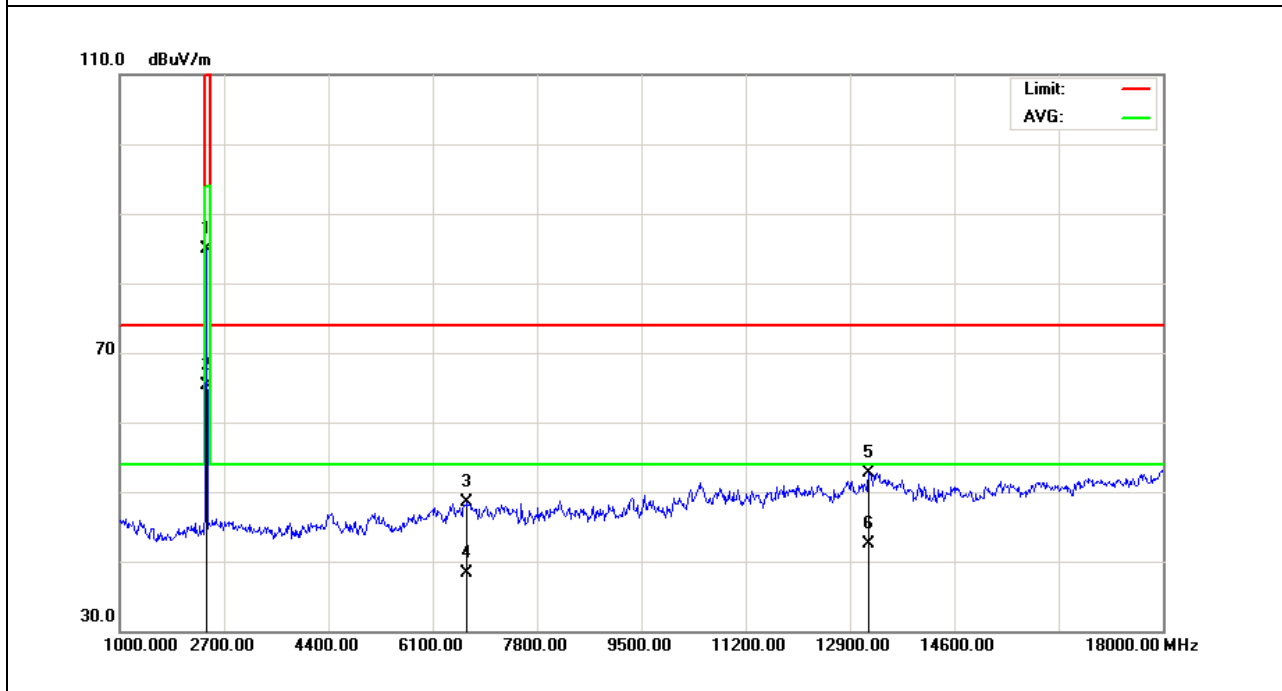

EUT :	Ridepad , GoGasm-Vibrating Balls	Model Name :	5947330000
Temperature :	25 °C	Relative Humidity :	51%
Pressure :	1010 hPa	Test Voltage :	DC 12V
Test Mode :	Mode 1-2407	Polarization :	Vertical

Frequency (MHz)	Meter Reading (dBμV)	Factor (dB)	Emission Level (dBμV/m)	Limits (dBμV/m)	Margin (dB)	Detector Type
2407.000	76.39	10.00	86.39	114.0	-27.61	peak
2407.000	56.33	10.00	66.33	94.00	-27.67	AVG
7783.000	27.27	22.59	49.86	74.00	-24.14	peak
7783.000	16.66	22.59	39.25	54.00	-14.75	AVG
15144.00	24.49	27.97	52.46	74.00	-21.54	peak
15144.00	12.23	27.97	40.20	54.00	-13.80	AVG

Remark:  
Factor = Antenna Factor + Cable Loss – Pre-amplifier.

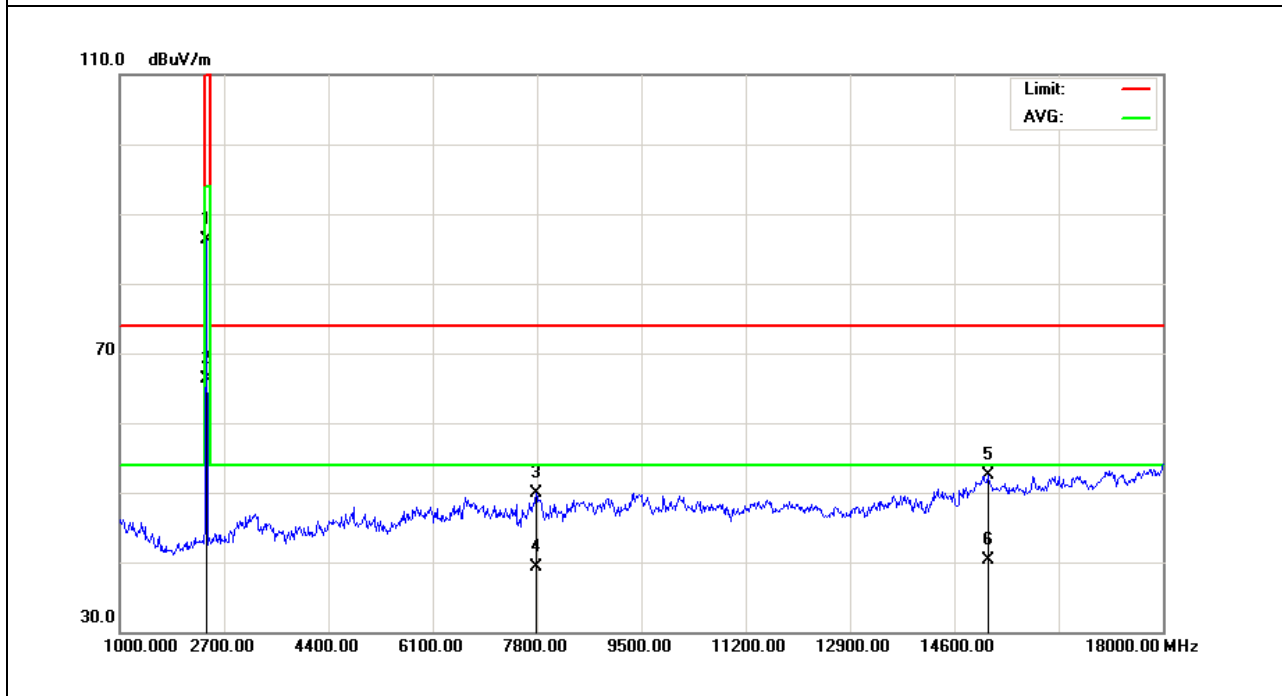



EUT :	Ridepad , GoGasm-Vibrating Balls	Model Name :	5947330000
Temperature :	25 °C	Relative Humidity :	51%
Pressure :	1010 hPa	Test Voltage :	DC 12V
Test Mode :	Mode 2-2448	Polarization :	Horizontal

Frequency (MHz)	Meter Reading (dBμV)	Factor (dB)	Emission Level (dBμV/m)	Limits (dBμV/m)	Margin (dB)	Detector Type
2448.000	74.50	10.13	84.63	114.0	-29.37	peak
2448.000	51.89	10.13	62.02	94.00	-31.98	AVG
7341.000	26.62	22.09	48.71	74.00	-25.29	peak
7341.000	16.05	22.09	38.14	54.00	-15.86	AVG
13342.00	23.04	28.62	51.66	74.00	-22.34	peak
13342.00	11.48	28.62	40.10	54.00	-13.90	AVG

Remark:  
Factor = Antenna Factor + Cable Loss – Pre-amplifier.

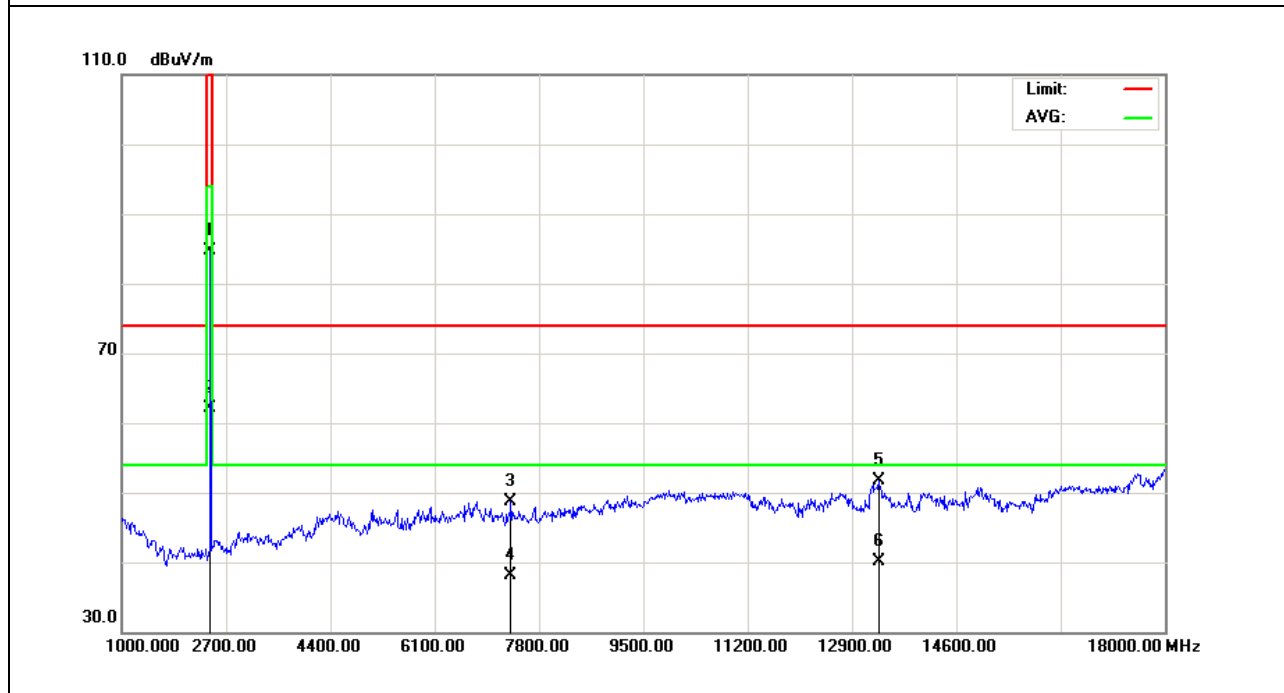

EUT :	Ridepad , GoGasm-Vibrating Balls	Model Name :	5947330000
Temperature :	25 °C	Relative Humidity :	51%
Pressure :	1010 hPa	Test Voltage :	DC 12V
Test Mode :	Mode 2-2448	Polarization :	Vertical

Frequency (MHz)	Meter Reading (dBμV)	Factor (dB)	Emission Level (dBμV/m)	Limits (dBμV/m)	Margin (dB)	Detector Type
2448.000	73.36	10.13	83.49	114.0	-30.51	peak
2448.000	59.97	10.13	70.10	94.00	-23.90	AVG
7341.000	29.22	22.09	51.31	74.00	-22.69	peak
7341.000	19.56	22.09	41.65	54.00	-12.35	AVG
14396.00	23.45	28.54	51.99	74.00	-22.01	peak
14396.00	12.04	28.54	40.58	54.00	-13.42	AVG

Remark:  
Factor = Antenna Factor + Cable Loss – Pre-amplifier.

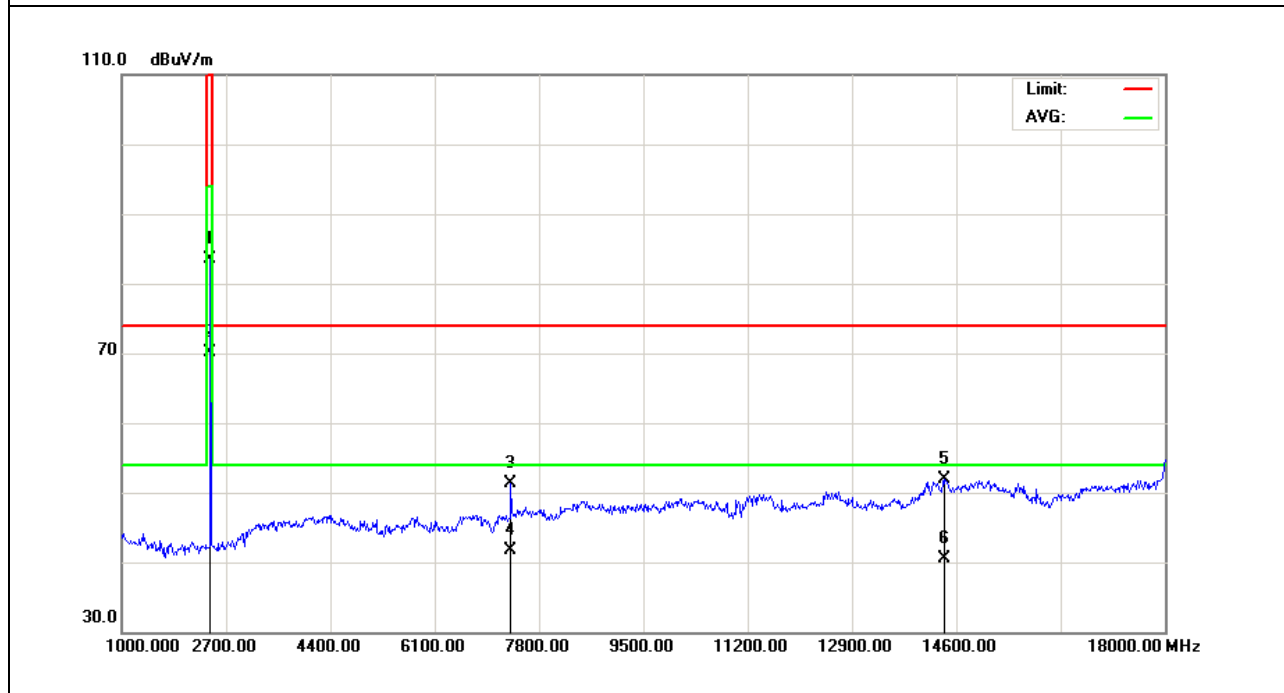

EUT :	Ridepad , GoGasm-Vibrating Balls	Model Name :	5947330000
Temperature :	25 °C	Relative Humidity :	51%
Pressure :	1010 hPa	Test Voltage :	DC 12V
Test Mode :	Mode 3-2459	Polarization :	Horizontal

Frequency (MHz)	Meter Reading (dBμV)	Factor (dB)	Emission Level (dBμV/m)	Limits (dBμV/m)	Margin (dB)	Detector Type
2459.000	74.10	10.17	84.27	114.0	-29.73	peak
2459.000	59.16	10.17	69.33	94.00	-24.67	AVG
7375.000	30.49	22.08	52.57	74.00	-21.43	peak
7375.000	17.94	22.08	40.02	54.00	-13.98	AVG
14158.00	24.50	28.53	53.03	74.00	-20.97	peak
14158.00	12.72	28.53	41.25	54.00	-12.75	AVG

Remark:  
Factor = Antenna Factor + Cable Loss – Pre-amplifier.

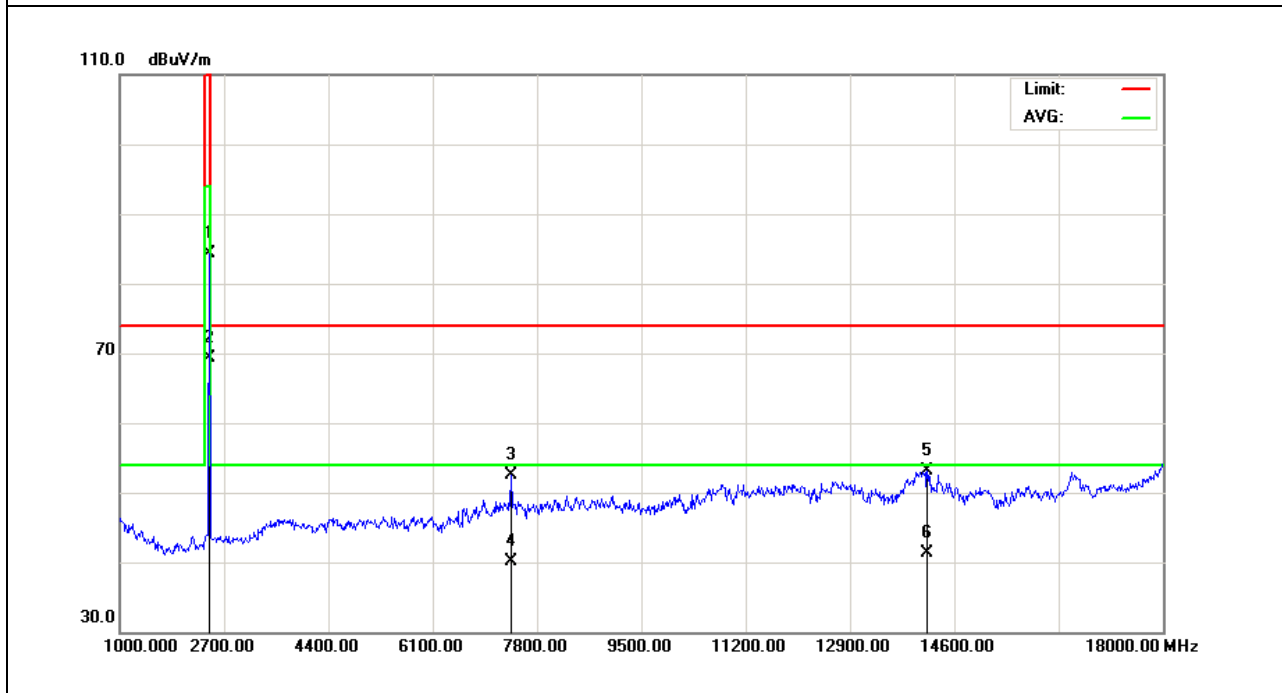

EUT :	Ridepad , GoGasm-Vibrating Balls	Model Name :	5947330000
Temperature :	25 °C	Relative Humidity :	51%
Pressure :	1010 hPa	Test Voltage :	DC 12V
Test Mode :	Mode 3-2459	Polarization :	Vertical

Note: Other emissions which has not list below has attenuated 20dB below the limit.

Frequency (MHz)	Meter Reading (dBμV)	Factor (dB)	Emission Level (dBμV/m)	Limits (dBμV/m)	Margin (dB)	Detector Type
2459.000	75.70	10.17	85.87	114.0	-28.13	peak
2459.000	60.28	10.17	70.45	94.00	-23.55	AVG
7375.000	29.73	22.08	51.81	74.00	-22.19	peak
7375.000	19.48	22.08	41.56	54.00	-12.44	AVG
13325.00	24.07	28.59	52.66	74.00	-21.34	peak
13325.00	14.19	28.59	42.78	54.00	-11.22	AVG

Remark:

Factor = Antenna Factor + Cable Loss – Pre-amplifier.

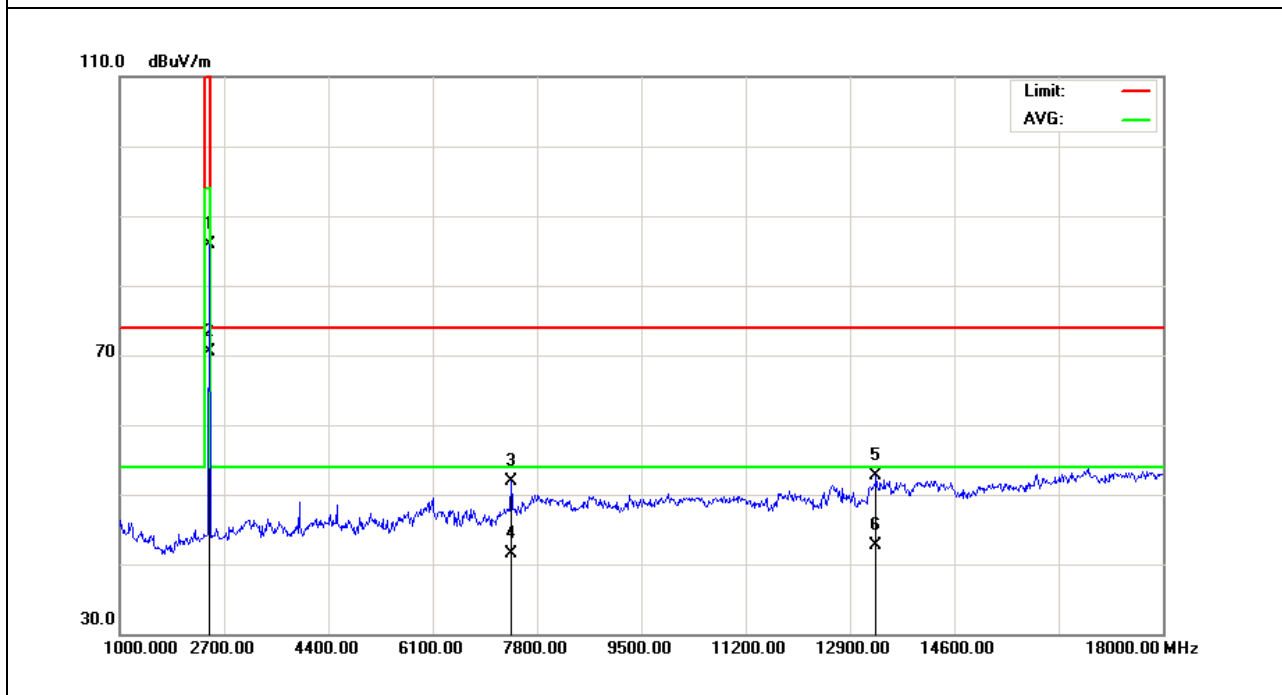

Note: EUT Pre-scan X/Y/Z orientation, only worst case is presented in the report(X orientation).

**3.4.7 TEST RESULTS (RESTRICTED BANDS REQUIREMENTS)**

EUT :	Ridepad , GoGasm-Vibrating Balls	Model Name :	5947330000
Temperature :	25 °C	Relative Humidity :	51%
Pressure :	1010 hPa	Test Voltage :	DC 12V
Test Mode :	TX-2407MHz	Polarization :	Horizontal

Frequency (MHz)	Meter Reading (dBμV)	Factor (dB)	Emission Level (dBμV/m)	Limits (dBμV/m)	Margin (dB)	Detector Type
2400.000	39.22	9.99	49.21	74.00	-24.79	peak
2400.000	30.23	9.99	40.22	54.00	-13.78	AVG

Remark:  
Factor = Antenna Factor + Cable Loss – Pre-amplifier.

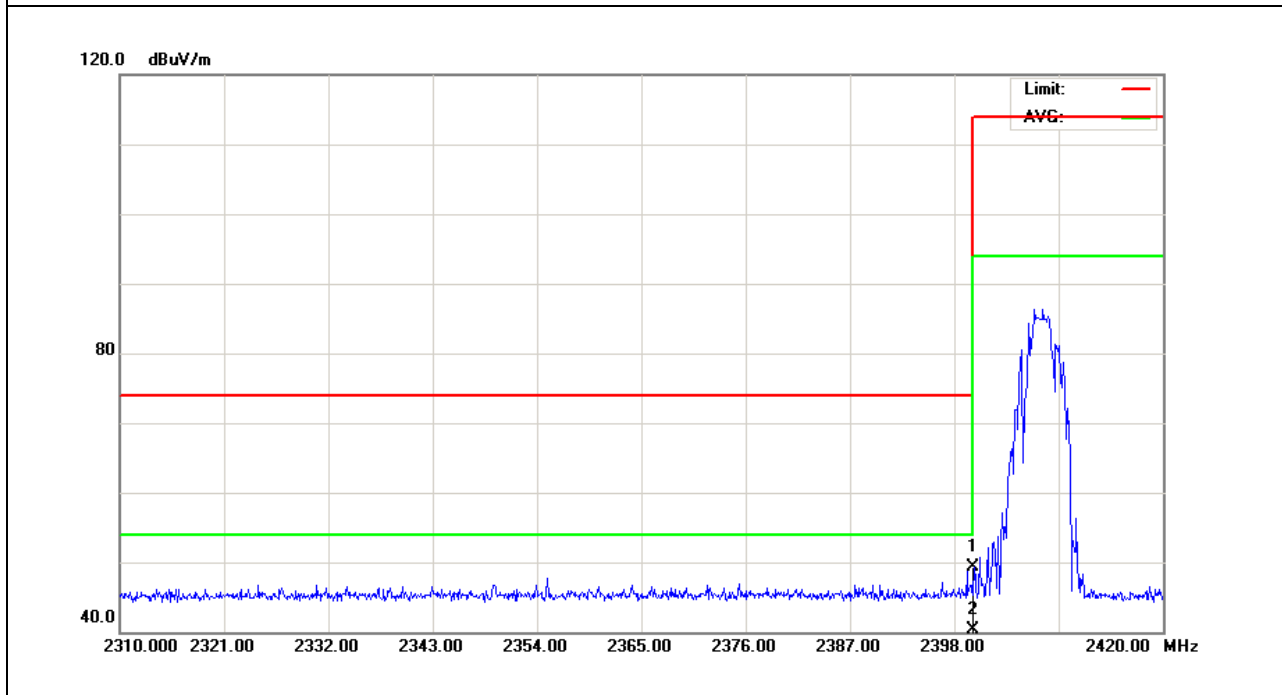

EUT :	Ridepad , GoGasm-Vibrating Balls	Model Name :	5947330000
Temperature :	25 °C	Relative Humidity :	51%
Pressure :	1010 hPa	Test Voltage :	DC 12V
Test Mode :	TX-2407MHz	Polarization :	Vertical

Frequency (MHz)	Meter Reading (dBμV)	Factor (dB)	Emission Level (dBμV/m)	Limits (dBμV/m)	Margin (dB)	Detector Type
2400.000	35.83	9.99	45.82	74.00	-28.18	peak
2400.000	31.25	9.99	41.24	54.00	-12.76	AVG

Remark:  
Factor = Antenna Factor + Cable Loss – Pre-amplifier.

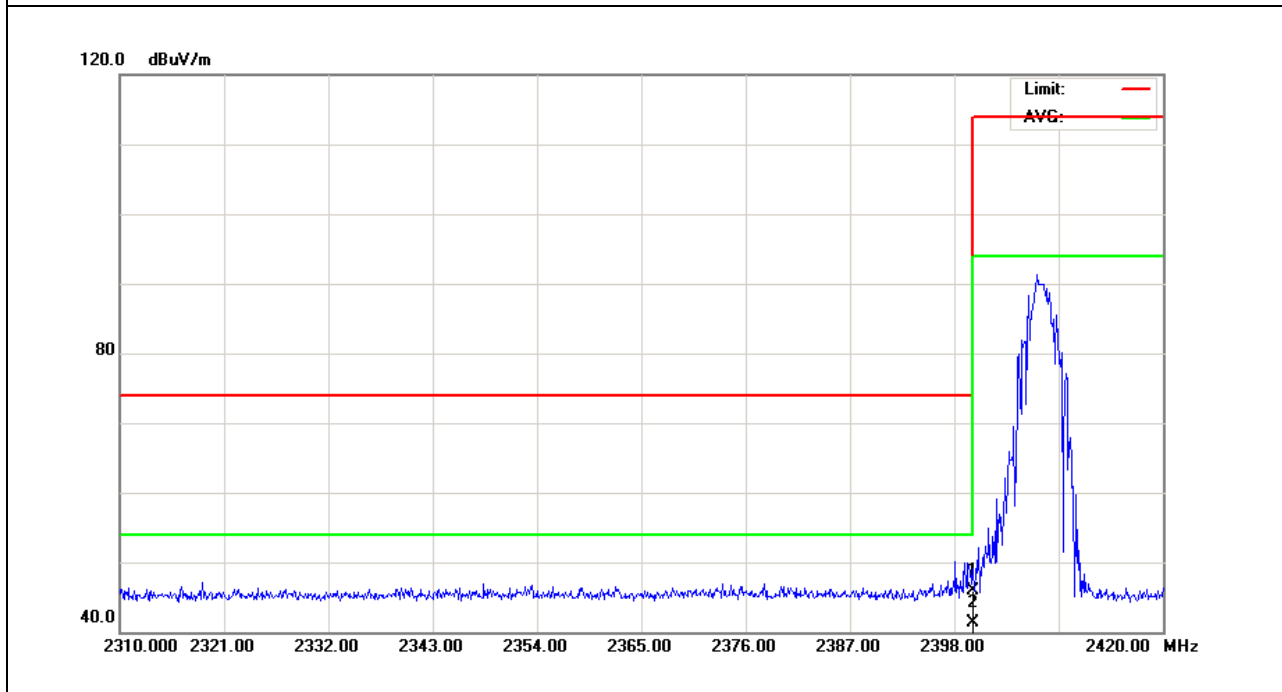

EUT :	Ridepad , GoGasm-Vibrating Balls	Model Name :	5947330000
Temperature :	25 °C	Relative Humidity :	51%
Pressure :	1010 hPa	Test Voltage :	DC 12V
Test Mode :	TX-2459MHz	Polarization :	Horizontal

Frequency (MHz)	Meter Reading (dBμV)	Factor (dB)	Emission Level (dBμV/m)	Limits (dBμV/m)	Margin (dB)	Detector Type
2483.500	35.90	10.28	46.18	74.00	-27.82	peak
2483.500	25.02	10.28	35.30	54.00	-18.70	AVG

Remark:  
Factor = Antenna Factor + Cable Loss – Pre-amplifier.

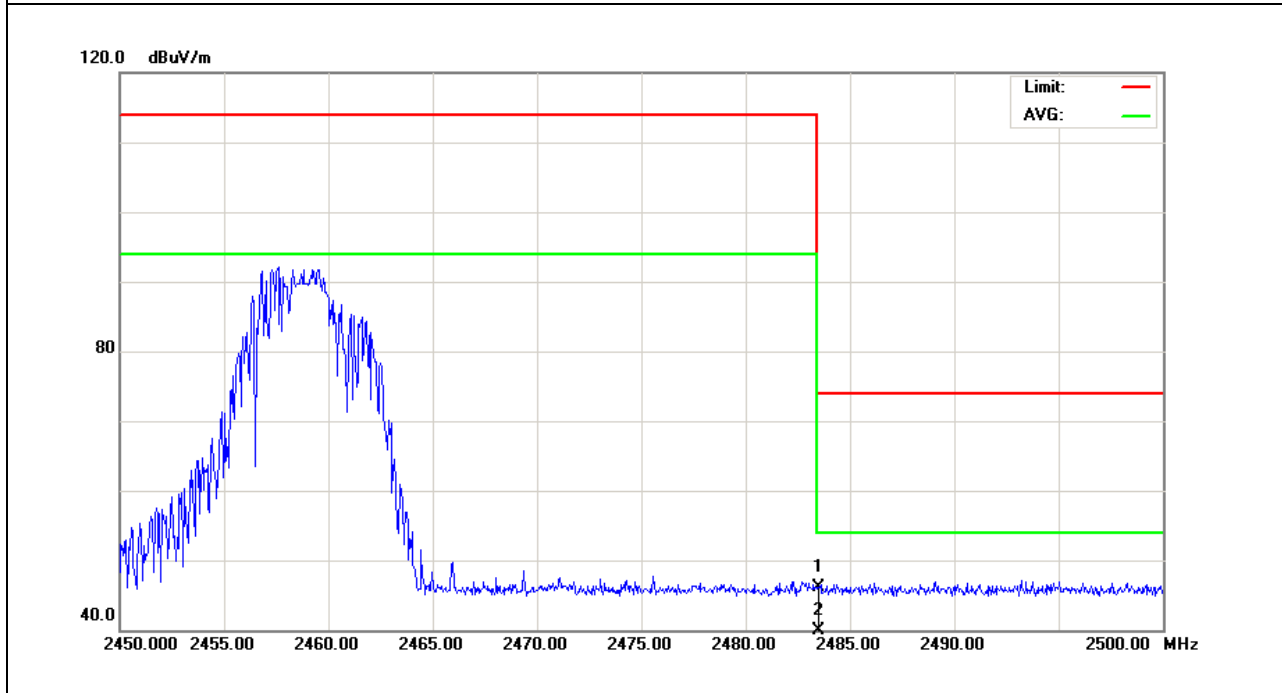

EUT :	Ridepad , GoGasm-Vibrating Balls	Model Name :	5947330000
Temperature :	25 °C	Relative Humidity :	51%
Pressure :	1010 hPa	Test Voltage :	DC 12V
Test Mode :	TX-2459MHz	Polarization :	Vertical

Frequency (MHz)	Meter Reading (dBμV)	Factor (dB)	Emission Level (dBμV/m)	Limits (dBμV/m)	Margin (dB)	Detector Type
2483.500	36.23	10.28	46.51	74.00	-27.49	peak
2483.500	28.92	10.28	39.20	54.00	-14.80	AVG

Remark:  
Factor = Antenna Factor + Cable Loss – Pre-amplifier.

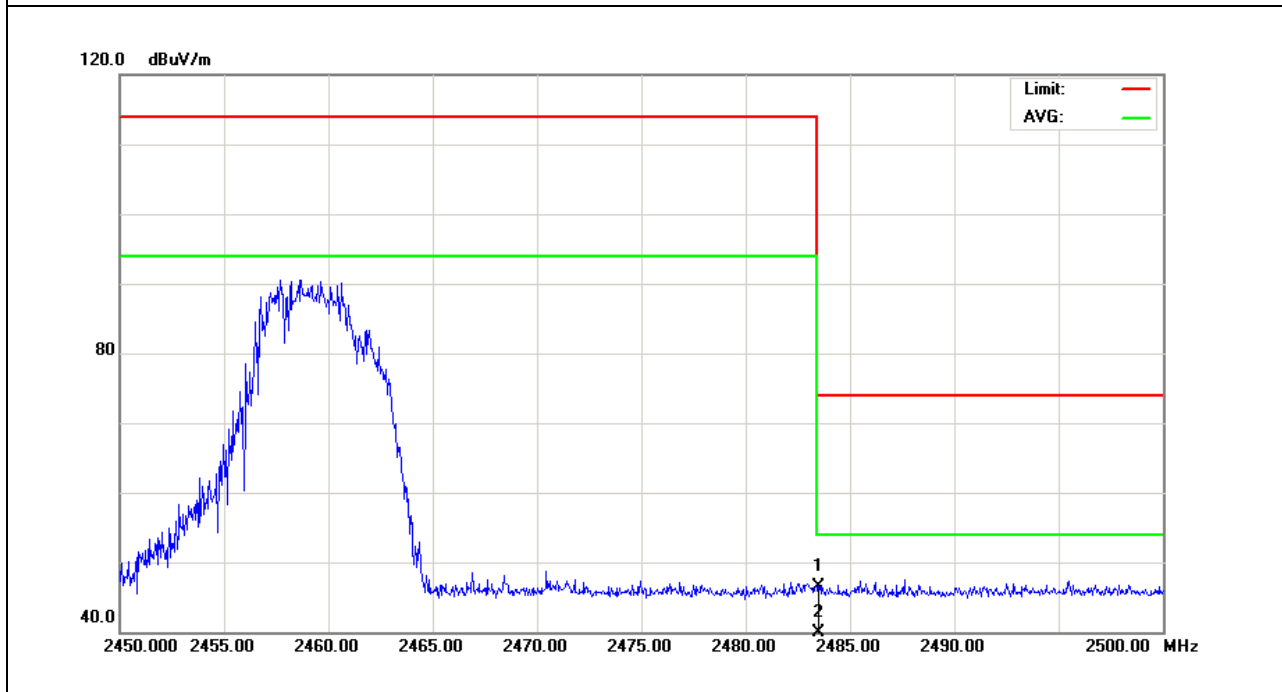



## 4. BANDWIDTH TEST

### 4.1 TEST PROCEDURE

- a. The EUT was directly connected to the spectrum analyzer and antenna output port as show in the block diagram below,
- b. Spectrum Setting : The resolution bandwidth (RBW) shall be in the range of 1% to 5% of the actual occupied / x dB bandwidth and the video bandwidth (VBW) shall not be smaller than three times the RBW value., Sweep time = Auto.

### 4.2 DEVIATION FROM STANDARD

No deviation.

### 4.3 TEST SETUP

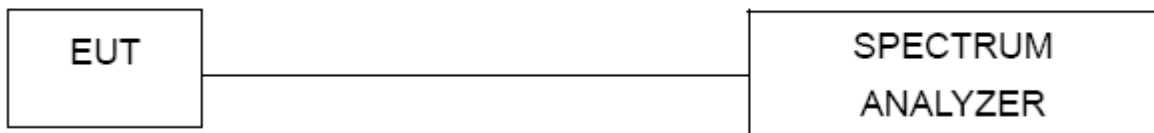

4.4. TEST RESULTS

EUT :	Ridepad , GoGasm-Vibrating Balls	Model Name :	5947330000
Temperature :	26 °C	Relative Humidity :	53%
Pressure :	1020 hPa	Test Power :	DC 12V
Test Mode :	Mode 1/2/3		

Test Channel	Frequency (MHz)	20 dBc Bandwidth (MHz)
CH01	2407	5.153

2407 MHz

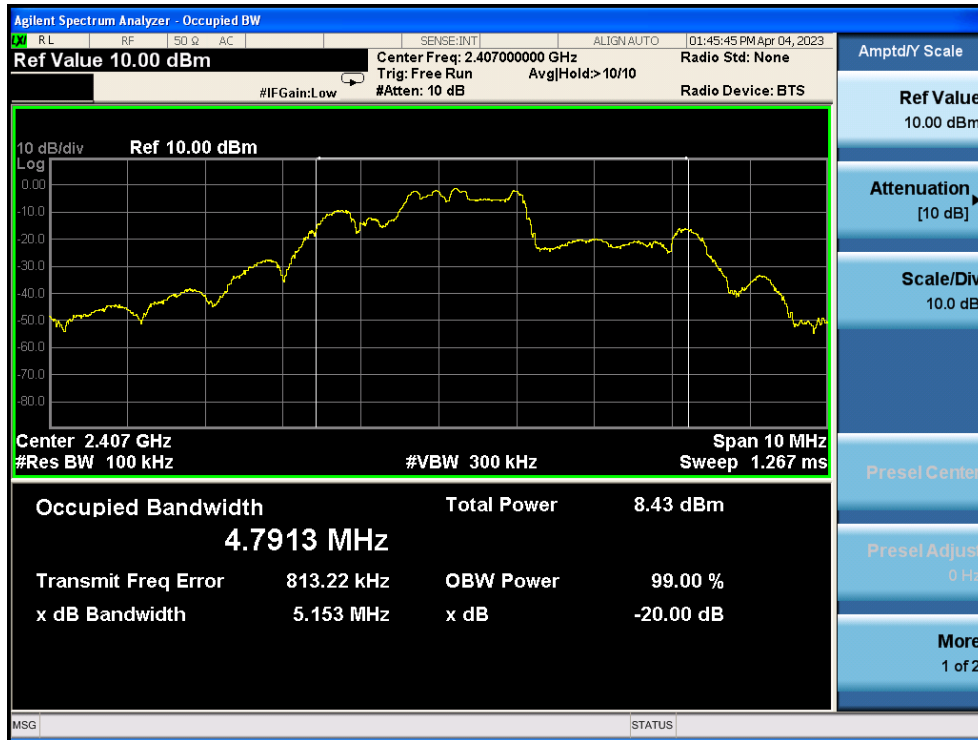

Test Channel	Frequency (MHz)	20 dBc Bandwidth (MHz)
CH02	2448	5.678

2448 MHz



Test Channel	Frequency (MHz)	20 dBc Bandwidth (MHz)
CH03	2459	5.791

2459 MHz



END OF REPORT