

FCC Part 15.247

TEST REPORT

For

Shanghai Xiangcheng Communication

Technology Co., Ltd

6th Floor, Building 10, No.3000 Longdong Avenue, Pudong New District,
Shanghai, China

FCC ID: 2A2UU-A1

Report Type: Original Report	Product Type: 80mm Receipt Printer
Report Producer : <u>Coco Lin</u>	
Report Number : <u>RLK231024085RF01</u>	
Report Date : <u>2024-03-20</u>	
Reviewed By: <u>Rory Cheng</u> 	
Prepared By: Bay Area Compliance Laboratories Corp.(Linkou Laboratory) No. 6, Wende 2Rd., Guishan Dist., Taoyuan City 33382, Taiwan (R.O.C.) Tel: +886 (3)3961072; Fax: +886 (3) 3961027 www.bacl.com.tw	

Revision History

Revision	No.	Report Number	Issue Date	Description	Author/ Revised by
0.0	RLK231024085	RLK231024085RF01	2024-03-20	Original Report	Coco Lin

TABLE OF CONTENTS

1. General Information.....	5
1.1. Product Description for Equipment under Test (EUT)	5
1.2. Objective	5
1.3. Related Submittal(s)/Grant(s).....	5
1.4. Test Methodology.....	5
1.5. Statement of Compliance	6
1.6. Measurement Uncertainty	6
1.7. Environmental Conditions.....	7
1.8. Test Facility	7
2. System Test Configuration.....	8
2.1. Description of Test Configuration.....	8
2.2. Equipment Modifications	8
2.3. Test Mode.....	8
2.4. EUT Exercise Software	8
2.5. Support Equipment List and Details.....	8
2.6. External Cable List and Details	9
2.7. Block Diagram of Test Setup	9
3. Summary of Test Results.....	11
4. Test Equipment List and Details	12
5. FCC §15.247(i), §1.1307(b)(3), §2.1091 - RF Exposure	13
5.1. Applicable Standard	13
5.2. RF Exposure Evaluation Result.....	14
6. FCC §15.203 – Antenna Requirements.....	15
6.1. Applicable Standard	15
6.2. Antenna Information	15
7. FCC §15.207(a) – AC Line Conducted Emissions	16
7.1. Applicable Standard	16
7.2. EUT Setup	16
7.3. EMI Test Receiver Setup	17
7.4. Test Procedure.....	17
7.5. Corrected Factor & Over Limit Calculation.....	17
7.6. Test Results	18
8. FCC §15.209, §15.205 , §15.247(d) – Spurious Emissions	19
8.1. Applicable Standard	19
8.2. EUT Setup	20
8.3. EMI Test Receiver & Spectrum Analyzer Setup.....	22
8.4. Test Procedure.....	22
8.5. Corrected Factor & Over Limit Calculation.....	22
8.6. Test Results	23
9. FCC §15.247(a)(1) – 20 dB Emission Bandwidth.....	33
9.1. Applicable Standard	33
9.2. Test Procedure.....	33
9.3. Test Results	33
10. FCC §15.247(a)(1) – Channel Separation Test.....	35

10.1. Applicable Standard 35
10.2. Test Procedure..... 35
10.3. Test Results 35
11. FCC §15.247(a)(1)(iii) –Time of Occupancy (Dwell Time) 38
11.1. Applicable Standard 38
11.2. Test Procedure..... 38
11.3. Test Results 39
12. FCC §15.247(a)(1)(iii) –Quantity of hopping channel Test..... 44
12.1. Applicable Standard 44
12.2. Test Procedure..... 44
12.3. Test Results 44
13. FCC §15.247(b)(1) – Maximum Output Power..... 45
13.1. Applicable Standard 45
13.2. Test Procedure..... 45
13.3. Test Results 45
14. FCC §15.247(d) – 100 kHz Bandwidth of Frequency Band Edge 46
14.1. Applicable Standard 46
14.2. Test Procedure..... 46
14.3. Test Results 46

1. General Information

1.1. Product Description for Equipment under Test (EUT)

Applicant	Shanghai Xiangcheng Communication Technology Co., Ltd
	6th Floor, Building 10, No.3000 Longdong Avenue, Pudong New District, Shanghai, China
Manufacturer	Shanghai Xiangcheng Communication Technology Co., Ltd
	6th Floor, Building 10, No.3000 Longdong Avenue, Pudong New District, Shanghai, China
Brand(Trade) Name	Shanghai Xiangcheng Communication Technology Co., Ltd
Product (Equipment)	80mm Receipt Printer
Main Model Name	A1
Frequency Range	2402 ~ 2480 MHz
Transmit Power	BR(GFSK) Mode: -2.86 dBm
Modulation Technique	BR Mode: GFSK
Power Operation (Voltage Range)	<input checked="" type="checkbox"/> DC 24V <input type="checkbox"/> Battery <input type="checkbox"/> DC Power Supply <input type="checkbox"/> External from USB Cable <input checked="" type="checkbox"/> External DC Adapter
	<input type="checkbox"/> Host System
Received Date	2023/10/24
Date of Test	2023/10/31 ~ 2024/03/20

* Note: All measurement and test data in this report was gathered from production sample serial number: RLK231024085-01. Assigned by BACL, Linkou Laboratory.

1.2. Objective

This report is prepared on behalf of Shanghai Xiangcheng Communication Technology Co., Ltd in accordance with Part 2, Subpart J, Part 15, Subparts A and C of the Federal Communication Commission’s rules.

The tests were performed in order to determine the Bluetooth BR mode of EUT compliance with FCC Part 15, Subpart C, and section 15.203, 15.205, 15.207, 15.209 and 15.247 rules.

1.3. Related Submittal(s)/Grant(s)

N/A.

1.4. Test Methodology

All measurements contained in this report were conducted with ANSI C63.10-2013, American National Standard of Procedures for Compliance Testing of Unlicensed Wireless Devices.

1.5. Statement of Compliance

Decision Rule: No, (The test results do not include MU judgment)

The measurement results in this report were performed at Bay Area Compliance Laboratories Corp. (Linkou Laboratory)

Any unauthorized alteration, forgery or falsification of the content or appearance of this document is unlawful and offenders may be prosecuted to the fullest extent of the law.

Unless otherwise stated the results shown in this test report refer only to the sample(s) tested.

The determination of the test results does not require consideration of the uncertainty of the measurement, unless the assessment is required by customer agreement, regulation or standard document specification. Bay Area Compliance Laboratories Corp. (Linkou Laboratory) is not responsible for the authenticity of the information provided by the applicant that affects the test results.

1.6. Measurement Uncertainty

Parameter		Uncertainty
AC Mains		±3.38 (dB)
RF output power, conducted		±3.74 (dB)
Power Spectral Density, conducted		±0.69 (dBm)
Occupied Bandwidth		±0.09 (%)
Unwanted Emissions, conducted		±1.13 (dB)
Emissions, radiated	9kHz~30 MHz	±4.13 (dB)
	30 MHz~1GHz	±5.34 (dB)
	1 GHz~18 GHz	±5.89 (dB)
	18 GHz~40 GHz	±5.52 (dB)
Temperature		±0.44 (%)
Humidity		±0.78 (°C)

1.7. Environmental Conditions

Test Site	Test Data	Temperature (°C)	Relative Humidity (%)	ATM Pressure (hPa)	Test Engineer
AC Line Conducted Emissions	2023/11/17	25.5	58	1010	Jean Lu
Radiation Spurious Emissions	2023/10/31~ 2024/03/20	22~25	45~51	1010	Allen Cheng
Conducted Spurious Emissions	2023/11/02	23.4	53	1010	Kevin Chou
20 dB Emission Bandwidth	2023/11/02	23.4	53	1010	Kevin Chou
Channel Separation Test	2023/11/02	23.4	53	1010	Kevin Chou
Time of Occupancy	2023/11/02	23.4	53	1010	Kevin Chou
Quantity of hopping channel	2023/11/02	23.4	53	1010	Kevin Chou
Maximum Output Power	2023/11/02	23.4	53	1010	Kevin Chou
100 kHz Bandwidth of Frequency Band Edge	2023/11/02	23.4	53	1010	Kevin Chou

1.8. Test Facility

The Test site used by Bay Area Compliance Laboratories Corp. (Linkou Laboratory) to collect test data is located on

No.6, Wende 2Rd., Guishan Dist., Taoyuan City 33382, Taiwan (R.O.C.).

Bay Area Compliance Laboratories Corp. (Linkou Laboratory) Lab is accredited to ISO 17025 by Taiwan Accreditation Foundation (TAF code: 3546) by Mutual Recognition Agreement (MRA). The test site has been approved by the FCC under the KDB 974614 D01 and is listed in the FCC Public Access Link (PAL) database. The FCC Registration No.: 0027578244. Designation No.: TW1119. The Test Firm Registration No.: 311381.

2. System Test Configuration

2.1. Description of Test Configuration

For BT mode, 79 channels are provided to testing:

Channel	Frequency (MHz)	Channel	Frequency (MHz)
1	2402	40	2441
2	2403	--	--
3	2404	--	--
4	2405	77	2478
--	--	78	2479
39	2440	79	2480

For BT Modes were tested with channel 1, 40 and 79.

The system was configured for testing in engineering mode, which was provided by manufacturer.

2.2. Equipment Modifications

No modification was made to the EUT.

2.3. Test Mode

Mode 1: Full System (model: A1) for all test item.

2.4. EUT Exercise Software

The test software was used “EspRFTestTool_v2.8_Manual(for WiFi), FCC_Test_Tool-v2.3(for BT, BLE)”

Test Frequency		2402MHz	2441MHz	2480MHz
Power Level Setting	GFSK	3	3	3

2.5. Support Equipment List and Details

Description	Manufacturer	Model Number	Serial Number
Notebook	DELL	E6410	8W66SM1
Adapter	Shenzhen Flypower Technology	PS65E240Y2500H	NA
Fixture 1	N/A	N/A	NA
Cash Register	N/A	N/A	NA
Fixture 2	N/A	N/A	NA

2.6. External Cable List and Details

Cable Description	Length (m)	From	To
Power Cable	1.2	EUT	Charger
RJ45 Cable	0.9	EUT	Notebook
USB Type C Cable	0.9	EUT	Notebook
RJ11 Cable	0.9	EUT	Cash Register
USB Type A extension cable	1.5	NB	Fixture 1
Mini USB cable	0.2	NB	Fixture 2

2.7. Block Diagram of Test Setup

See test photographs attached in annex setup photos for the actual connections between EUT and support equipment.

Radiation:

Below 1GHz:

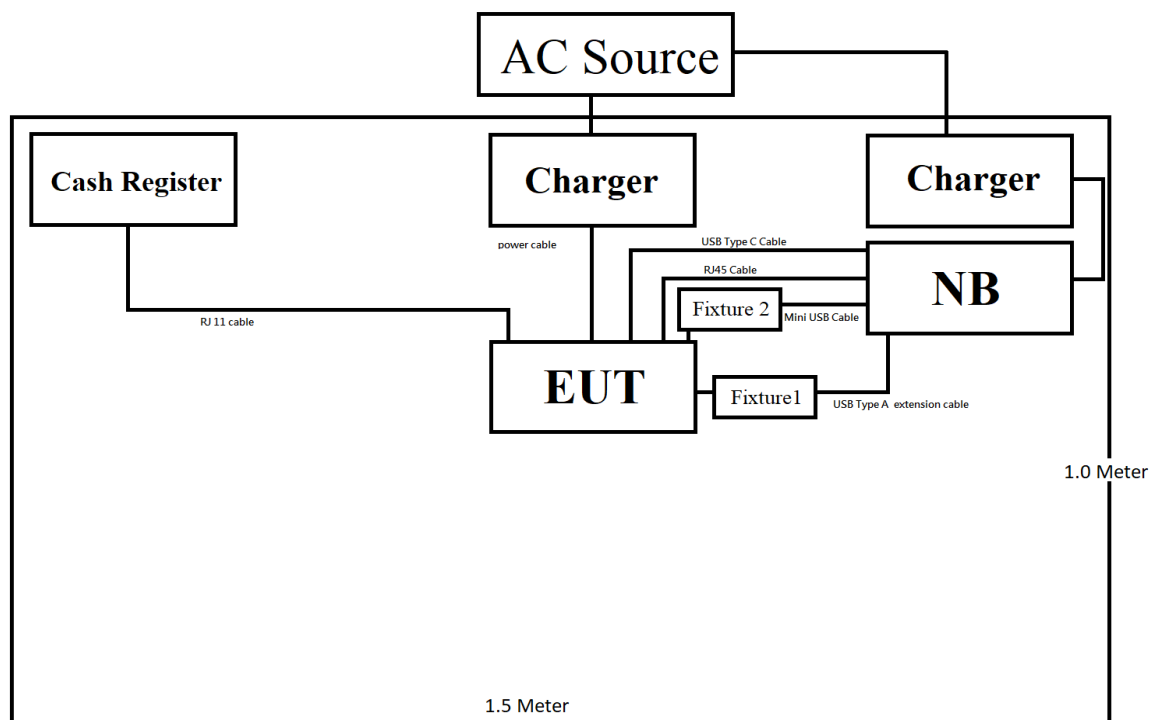

Non-Conductive Table 80cm above Ground Plane

Above 1GHz:

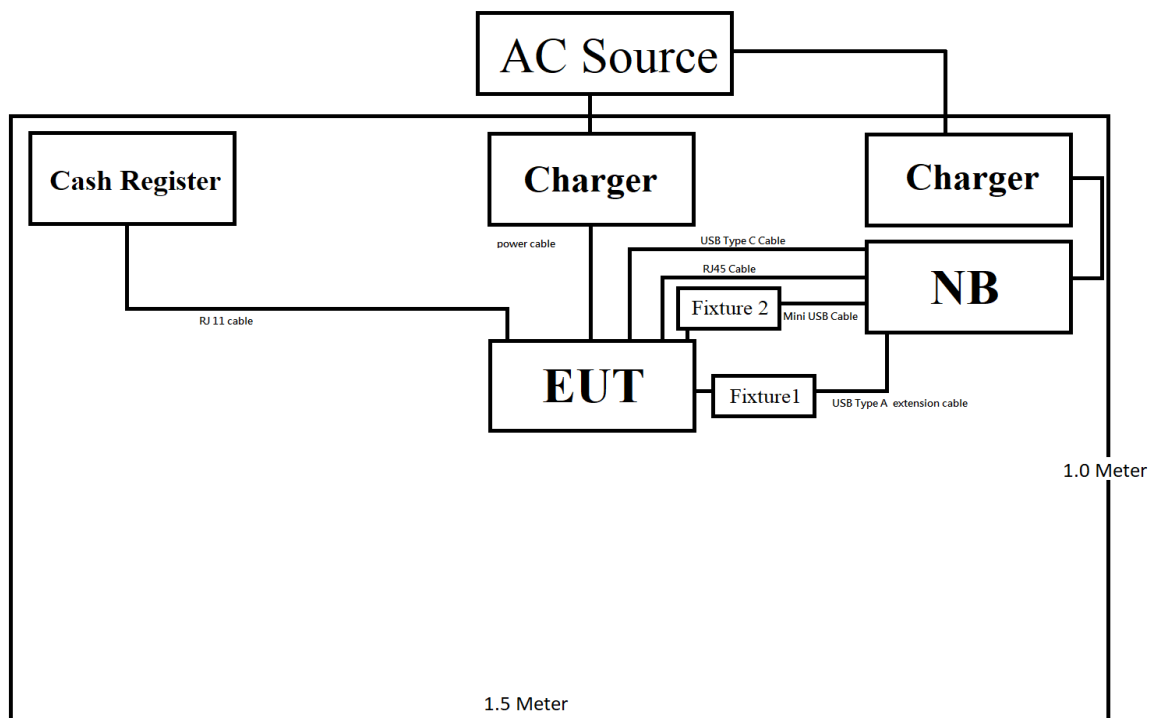

Non-Conductive Table 150cm above Ground Plane

Conduction:

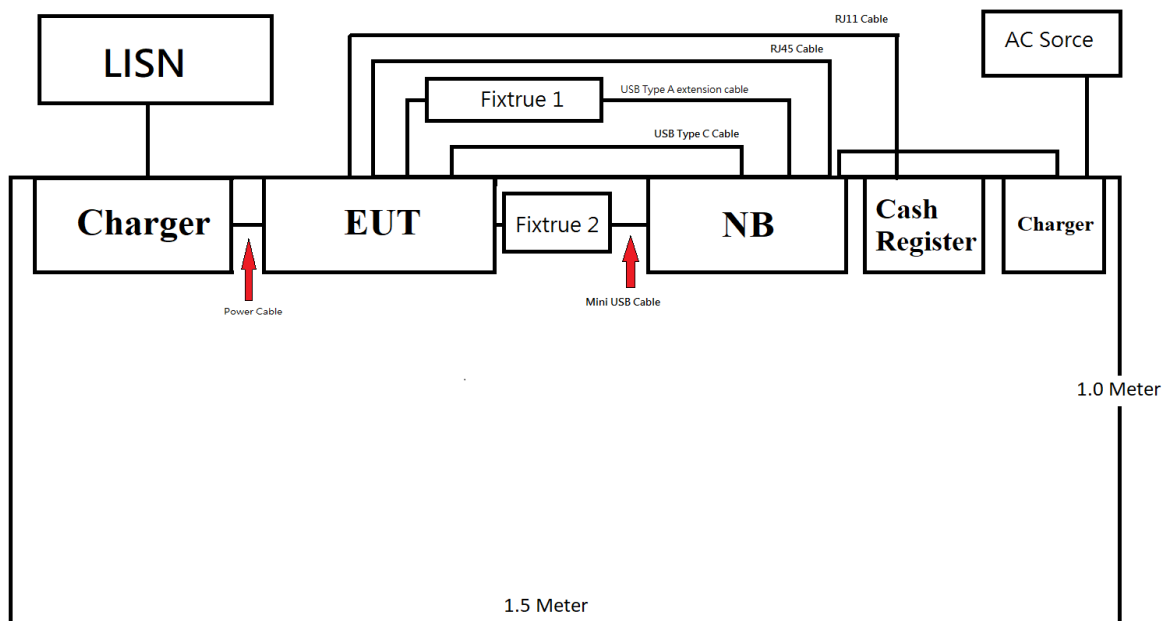

Non-Conductive Table 150cm above Ground Plane

Conducted:

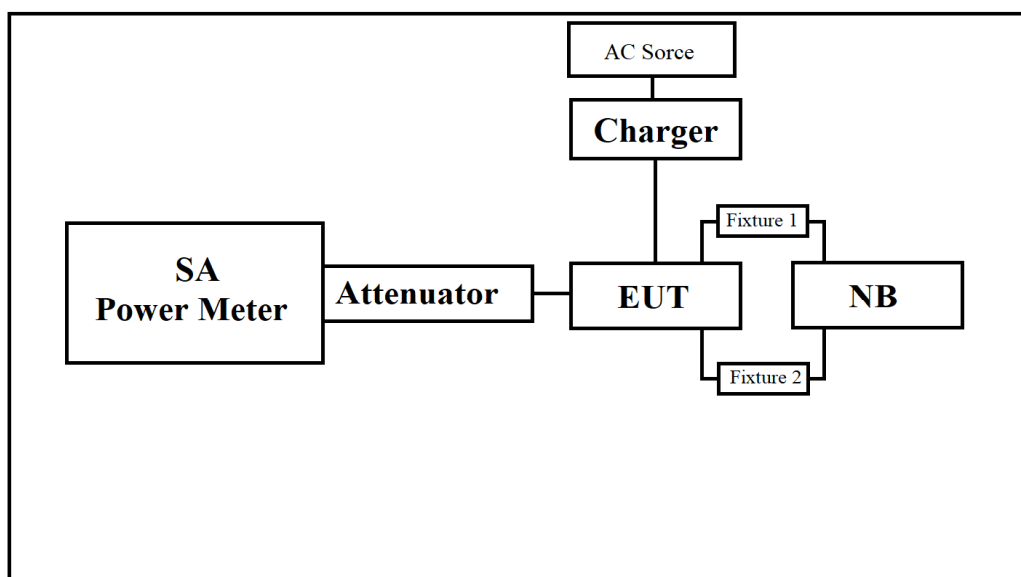

3. Summary of Test Results

FCC Rules	Description of Test	Results
§15.247(i), §1.1310, §2.1091	Maximum Permissible Exposure (MPE)	Compliance
§15.203	Antenna Requirement	Compliance
§15.207(a)	AC Line Conducted Emissions	Compliance
§15.205, §15.209, §15.247(d)	Spurious Emissions	Compliance
§15.247(a)(1)	20 dB Emission Bandwidth	Compliance
§15.247 (a)(1)	Channel Separation Test	Compliance
§15.247(a)(1)(iii)	Time of Occupancy (Dwell Time)	Compliance
§15.247(a)(1)(iii)	Quantity of hopping channel Test	Compliance
§15.247(b)(1)	Maximum Peak Output Power	Compliance
§15.247(d)	100 kHz Bandwidth of Frequency Band Edge	Compliance

4. Test Equipment List and Details

Description	Manufacturer	Model	Serial Number	Calibration Date	Calibration Due Date
AC Line Conduction Room (CON-A)					
Two-Line-V-Network	Rohde & Schwarz	ENV216	100037	2023/09/13	2024/09/11
EMI Test Receiver	Rohde & Schwarz	ESCI 7	100769	2023/03/09	2024/03/07
Pulse Limiter	SCHWARZBECK	VTSD 9561-F	00432	2023/08/14	2024/08/12
RF Cable	EMCI	EMCCFD3 00-BM-BM-3000	221013	2023/10/17	2024/10/15
Software	Audix	e3 v9	E3LK-03	N.C.R	N.C.R
Radiation 3M Room (966-B)					
Bilog Antenna	SUNOL SCIENCES & EMCI	JB3 & N-6-06	A071318 & AT-N0670	2023/08/24	2024/08/22
Active Loop Antenna	ETS-Lindgren	6502	0001-3322	2023/03/23	2024/03/22
Horn Antenna	ETS-Lindgren	3115	40736	2023/04/06	2024/04/04
Horn Antenna	ETS-Lindgren	3160-09	00123853	2023/08/29	2024/08/27
Horn Antenna	ETS-Lindgren	3160-10	00123856	2023/08/29	2024/08/27
Amplifier	Sonoma	310N	250609	2023/09/13	2024/09/11
Preamplifier	A.H. Systems	PAM-0118P	479	2023/09/07	2024/09/05
ESR EMI Test Receiver	Rohde & Schwarz	ESR3	102430	2023/04/20	2024/04/18
Signal and Spectrum Analyzer	Rohde & Schwarz	FSV40	101456	2023/05/23	2024/05/21
Microflex Cable (1m)	EMCI	EMCI02-KM-KM-1000	180524	2023/08/03	2024/08/01
Microflex Cable (2m)	EMCI	EMCI06-SM-SM-2000	180516	2023/08/03	2024/08/01
Microflex Cable (8m)	UTIFLEX	UFA210A-1-3149-300300	MFR 64639 232490-002	2023/08/03	2024/08/01
Band Reject Filter	Xi'an Xingbo	XBLBQ-DZA81	190329-1-07	2023/04/06	2024/04/05
High Pass Filter	Xi'an Xingbo	XBLBQ-GTA54	190329-1-27	2023/04/06	2024/04/05
Band Reject Filter	Xi'an Xingbo	XBLBQ-DTD10	200121-3-28	2023/04/06	2024/04/05
Software	AUDIX	E3 V9	E3LK-02	N.C.R	N.C.R
Conducted Room					
Spectrum Analyzer	Rohde & Schwarz	FSV40	101938	2022/12/7	2023/12/6
Cable	MTJ	MT40S	620620-MT40S-100	2022/12/23	2023/12/22
USB Wideband Power Sensor	AGILENT	U2021XA	MY54080011	2023/08/30	2024/08/28
10dB Attenuator	MCL	BW-S10W5+	605	2023/03/22	2024/03/20

***Statement of Traceability:** BACL Corp. attests that all of the calibrations on the equipment items listed above were traceable to the SI System of Units via the R.O.C. Center for Measurement Standards of the Electronics Testing Center, Taiwan (ETC) or to another internationally recognized National Metrology Institute (NMI), and were compliant with the current Taiwan Accreditation Foundation (TAF) requirements

5. FCC §15.247(i), §1.1307(b)(3), §2.1091 - RF Exposure

5.1. Applicable Standard

According to subpart 15.247(i) and subpart §2.1091, systems operating under the provisions of this section shall be operated in a manner that ensures that the public is not exposed to radio frequency energy level in excess of the Commission’s guidelines.

For single RF sources (i.e., any single fixed RF source, mobile device, or portable device, as defined in paragraph (b)(2) of this section): A single RF source is exempt if:

(A) The available maximum time-averaged power is no more than 1 mW, regardless of separation distance. This exemption may not be used in conjunction with other exemption criteria other than those in paragraph (b)(3)(ii)(A) of this section. Medical implant devices may only use this exemption and that in paragraph (b)(3)(ii)(A);

(B) Or the available maximum time-averaged power or effective radiated power (ERP), whichever is greater, is less than or equal to the threshold Pth (mW) described in the following formula. This method shall only be used at separation distances (cm) from 0.5 centimeters to 40 centimeters and at frequencies from 0.3 GHz to 6 GHz (inclusive). Pth is given by:

$$P_{th} \text{ (mW)} = \begin{cases} ERP_{20 \text{ cm}} (d/20 \text{ cm})^x & d \leq 20 \text{ cm} \\ ERP_{20 \text{ cm}} & 20 \text{ cm} < d \leq 40 \text{ cm} \end{cases}$$

Where

$$x = -\log_{10} \left(\frac{60}{ERP_{20 \text{ cm}} \sqrt{f}} \right) \text{ and } f \text{ is in GHz;}$$

and

$$ERP_{20 \text{ cm}} \text{ (mW)} = \begin{cases} 2040f & 0.3 \text{ GHz} \leq f < 1.5 \text{ GHz} \\ 3060 & 1.5 \text{ GHz} \leq f \leq 6 \text{ GHz} \end{cases}$$

(C) Or using Table 1 and the minimum separation distance (R in meters) from the body of a nearby person for the frequency (f in MHz) at which the source operates, the ERP (watts) is no more than the calculated value prescribed for that frequency. For the exemption in Table 1 to apply, R must be at least $\lambda/2\pi$, where λ is the free-space operating wavelength in meters. If the ERP of a single RF source is not easily obtained, then the available maximum time-averaged power may be used in lieu of ERP if the physical dimensions of the radiating structure(s) do not exceed the electrical length of $\lambda/4$ or if the antenna gain is less than that of a half-wave dipole (1.64 linear value).

Table 1 to § 1.1307(b)(3)(i)(C) - Single RF Sources Subject to Routine Environmental Evaluation

RF Source frequency (MHz)	Threshold ERP (watts)
0.3-1.34	1,920 R ² .
1.34-30	3,450 R ² /f ² .
30-300	3.83 R ² .
300-1,500	0.0128 R ² f.
1,500-100,000	19.2R ² .

Note: It may not be duplicated or used in part without prior written consent from Bay Area Compliance Laboratories Corp. (Linkou Laboratory)

For multiple RF sources: Multiple RF sources are exempt if: in the case of fixed RF sources operating in the same time-averaging period, or of multiple mobile or portable RF sources within a device operating in the same time averaging period, if the sum of the fractional contributions to the applicable thresholds is less than or equal to 1 as indicated in the following equation:

$$\sum_{i=1}^a \frac{P_i}{P_{th,i}} + \sum_{j=1}^b \frac{ERP_j}{ERP_{th,j}} + \sum_{k=1}^c \frac{Evaluated_k}{Exposure Limit_k} \leq 1$$

5.2. RF Exposure Evaluation Result

Project info

Band	Freq (MHz)	Tune up Power (dBm)	Distances (mm)	Duty (%)	Tune up Power (mW)	ERP (dBm)	ERP (mW)
BLE	2402	-2.5	200	100%	0.56	-3.05	0.50
2.4G WIFI	2462	15.53	200	100%	35.73	17.15	51.88

§ 1.1307(b)(3)(i)(A) method is not applicable.

Band	Freq (MHz)	Result
BT	2402	exempt
2.4G WIFI	2462	not exempt

§ 1.1307(b)(3)(i)(C)

Band	Freq (MHz)	$\lambda/2\pi$ (mm)	Distances applies	ERP Limit (mW)	Result
BT	2402	19.88	apply	768.00	exempt
2.4G WIFI	2462	19.39	apply	768.00	exempt

The minimum separation distance (R in meters) from the body of a nearby person for the frequency (f in MHz) at which the source operates

ERP (watts) is no more than the calculated value prescribed for that frequency

R must be at least $\lambda / 2\pi$

λ is the free-space operating wavelength in meters

Simultaneous Analysis

Band	Freq (MHz)	Simultaneous TX	Ratio
BT	2402	O	0.001
2.4G WIFI	2462	O	0.068
Simultaneous Analysis (Limit 1)			0.068

The Wi-Fi data in the report comes form RXA1709-0323RF02R3 and FCC ID: 2AC7Z-ESPWROOM02D, issued by TA Technology (Shanghai) Co., Ltd.

The BT and Wi-Fi can transmit simultaneously.

Simultaneous transmitting consideration (worst case):

The ratio= $ERP_{BT}/limit + ERP_{Wi-Fi}/limit=0.5/768+51.88/768=0.068 < 1.0$

So simultaneous exposure is compliant.

Result: The device compliant.

6. FCC §15.203 – Antenna Requirements

6.1. Applicable Standard

According to § 15.203,

An intentional radiator shall be designed to ensure that no antenna other than that furnished by the responsible party shall be used with the device. The use of a permanently attached antenna or of an antenna that uses a unique coupling to the intentional radiator shall be considered sufficient to comply with the provisions of this section. The manufacturer may design the unit so that a broken antenna can be replaced by the user, but the user of a standard antenna jack or electrical connector is prohibited.

And according to FCC 47 CFR section 15.247 (b), if the transmitting antennas of directional gain greater than 6dBi are used, the power shall be reduced by the amount in dB that the directional gain of the antenna does not exceed 6dBi.

6.2. Antenna Information

Manufacturer	Model	Type	Antenna Gain
Gan zhou Sun&Lynn Circuits.,Ltd	XC_RF_A1_BT_001/	PCB Antenna	1.6 dBi

Result: Compliance

7. FCC §15.207(a) – AC Line Conducted Emissions

7.1. Applicable Standard

According to §15.207

For an intentional radiator that is designed to be connected to the public utility (AC) power line, the radio frequency voltage that is conducted back onto the AC power line on any frequency or frequencies within the band 150 kHz to 30 MHz shall not exceed the limits in the following table, as measured using a 50 μH/50 ohms line impedance stabilization network (LISN). Compliance with the provisions of this paragraph shall be based on the measurement of the radio frequency voltage between each power line and ground at the power terminal. The lower limit applies at the boundary between the frequencies ranges.

Frequency of Emission (MHz)	Conducted Limit (dBuV)	
	Quasi-Peak	Average
0.15-0.5	66 to 56 ^{Note 1}	56 to 46 ^{Note 2}
0.5-5	56	46
5-30	60	50

Note 1: Decreases with the logarithm of the frequency.

Note 2: A linear average detector is required

7.2. EUT Setup

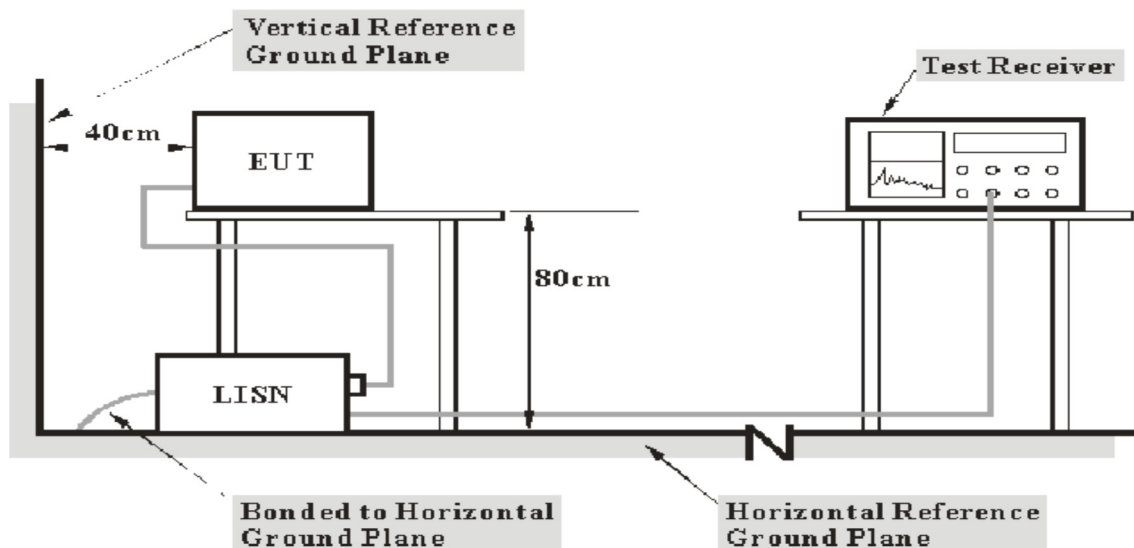

- Note:**
1. Support units were connected to second LISN.
 2. Both of LISNs (AMN) 80 cm from EUT and at the least 80 cm from other units and other metal planes support units.

The setup of EUT is according with per ANSI C63.10-2013 measurement procedure. The specification used was with the FCC Part 15.207 limits.

7.3. EMI Test Receiver Setup

The EMI test receiver was set to investigate the spectrum from 150kHz to 30MHz.

During the conducted emission test, the EMI test receiver was set with the following configurations

Frequency Range	IF B/W
150kHz – 30MHz	9kHz

7.4. Test Procedure

During the conducted emission test, the adapter was connected to the outlet of the LISN.

Maximizing procedure was performed on the six (6) highest emissions of the EUT.

All data was recorded in the Quasi-peak and average detection mode.

7.5. Corrected Factor & Over Limit Calculation

The factor is calculated by adding LISN/ISN VDF (Voltage Division Factor), Cable Loss and Transient Limiter Attenuation. The basic equation is as follows:

$$\text{Factor} = \text{LISN VDF} + \text{Cable Loss} + \text{Transient Limiter Attenuation}$$

The “Over Limit” column of the following data tables indicates the degree of compliance with the applicable limit. For example, an over limit of -7 dB means the emission is 7 dB below the limit. The equation for Over Limit calculation is as follows:

$$\text{Over Limit} = \text{Level} - \text{Limit Line}$$

7.6. Test Results

Test Mode: Transmitting

Main: AC120 V, 60 Hz

worst case is BR(GFSK) mode Middle channel

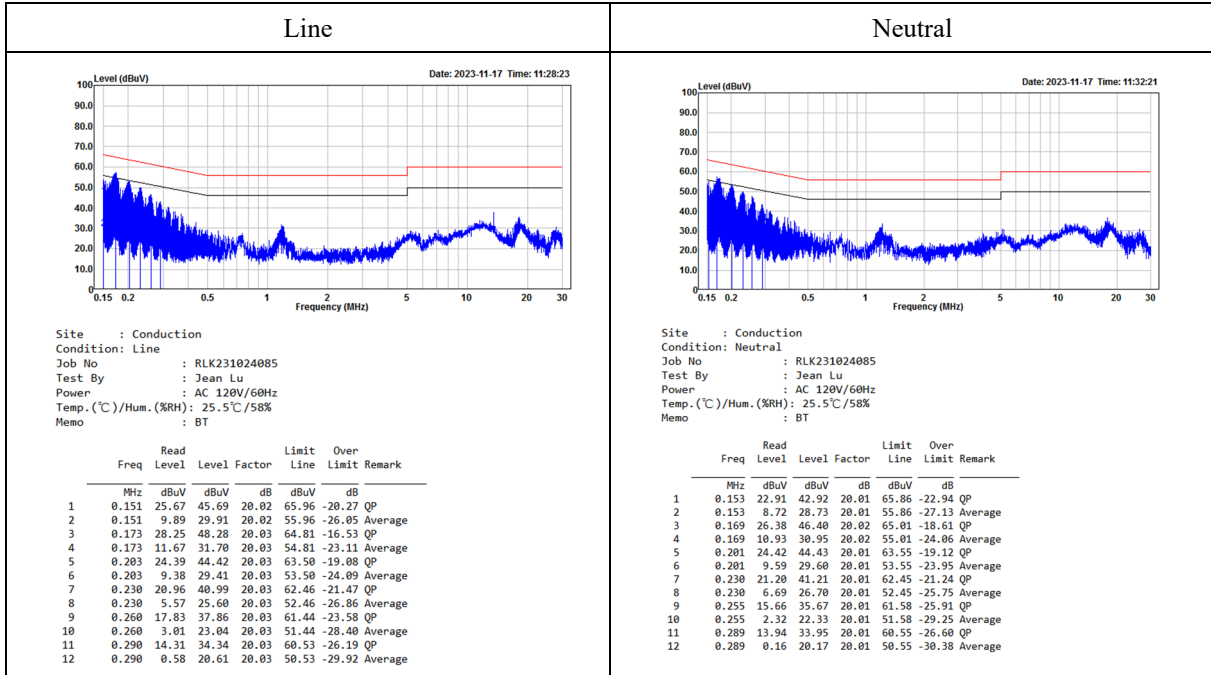

Note:

Level = Read Level + Factor

Over Limit = Level – Limit Line

Factor = (LISN, ISN, PLC or current probe) Factor + Cable Loss + Attenuator

8. FCC §15.209, §15.205 , §15.247(d) – Spurious Emissions

8.1. Applicable Standard

As per FCC §15.35(d): Unless otherwise specified, on any frequency or frequencies above 1000 MHz, the radiated emission limits are based on the use of measurement instrumentation employing an average detector function. Unless otherwise specified, measurements above 1000 MHz shall be performed using a minimum resolution bandwidth of 1MHz.

As Per FCC §15.205(a) except as show in paragraph (d) of this section, only spurious emissions are permitted in any of the frequency bands listed below:

MHz	MHz	MHz	GHz
0.090 – 0.110	16.42 – 16.423	608 – 614	4. 5 – 5. 15
0.495 – 0.505	16.69475 – 16.69525	960 – 1240	5. 35 – 5. 46
2.1735 – 2.1905	16.80425 – 16.80475	1300 – 1427	7.25 – 7.75
4.125 – 4.128	25.5 – 25.67	1435 – 1626.5	8.025 – 8.5
4.17725 – 4.17775	37.5 – 38.25	1645.5 – 1646.5	9.0 – 9.2
4.20725 – 4.20775	73 – 74.6	1660 – 1710	9.3 – 9.5
6.215 – 6.218	74.8 – 75.2	1718.8 – 1722.2	10.6 – 12.7
6.26775 – 6.26825	108 – 121.94	2200 – 2300	13.25 – 13.4
6.31175 – 6.31225	123 – 138	2310 – 2390	14.47 – 14.5
8.291 – 8.294	149.9 – 150.05	2483.5 – 2500	15.35 – 16.2
8.362 – 8.366	156.52475 – 156.52525	2690 – 2900	17.7 – 21.4
8.37625 – 8.38675	156.7 – 156.9	3260 – 3267	22.01 – 23.12
8.41425 – 8.41475	162.0125 – 167.17	3.332 – 3.339	23.6 – 24.0
12.29 – 12.293	167.72 – 173.2	3 3458 – 3 358	31.2 – 31.8
12.51975 – 12.52025	240 – 285	3.600 – 4.400	36.43 – 36.5
12.57675 – 12.57725	322 – 335.4		Above 38.6
13.36 – 13.41	399.9 – 410		

As per FCC §15.209(a): Except as provided elsewhere in this Subpart, the emissions from an intentional radiator shall not exceed the field strength levels specified in the following table:

Frequency (MHz)	Field Strength (micro volts/meter)	Measurement Distance (meters)
0.009 - 0.490	2400/F(kHz)	300
0.490 - 1.705	24000/F(kHz)	30
1.705 - 30.0	30	30
30 - 88	100**	3
88 - 216	150**	3
216 - 960	200**	3
Above 960	500	3

** Except as provided in paragraph (g), fundamental emissions from intentional radiators operating under this Section shall not be located in the frequency bands 54-72 MHz, 76-88 MHz, 174-216 MHz or 470-806 MHz. However, operation within these frequency bands is permitted under other sections of this Part, e.g., Sections 15.231 and 15.241.

According to ANSI C63.10-2013, section 5.3.3

Measurements may be performed at a distance other than the limit distance provided they are not performed in the near field, and the emissions to be measured can be detected by the measurement equipment (see 4.3.4). Measurements shall not be performed at a distance greater than 30 m for frequencies above 30 MHz, unless it can be further demonstrated that measurements at a distance of 30 m or less are impractical. Measurements from 18 GHz to 40 GHz are typically made at distances significantly less than 3 m from the EUT. When performing measurements at a distance other than that specified, the results shall be extrapolated to the specified distance using an extrapolation factor of 20 dB/decade of distance (inverse of linear distance for field-strength measurements or inverse of linear distance-squared for power-density measurements).

As per FCC §15.247 (d) In any 100 kHz bandwidth outside the frequency band in which the spread spectrum or digitally modulated intentional radiator is operating, the radio frequency power that is produced by the intentional radiator shall be at least 20 dB below that in the 100 kHz bandwidth within the band that contains the highest level of the desired power, based on either an RF conducted or a radiated measurement, provided the transmitter demonstrates compliance with the peak conducted power limits. If the transmitter complies with the conducted power limits based on the use of RMS averaging over a time interval, as permitted under paragraph (b)(3) of this section, the attenuation required under this paragraph shall be 30 dB instead of 20 dB. Attenuation below the general limits specified in §15.209(a) is not required. In addition, radiated emissions which fall in the restricted bands, as defined in §15.205(a), must also comply with the radiated emission limits specified in §15.209(a) (see §15.205(c)).

8.2. EUT Setup

9kHz-30MHz:

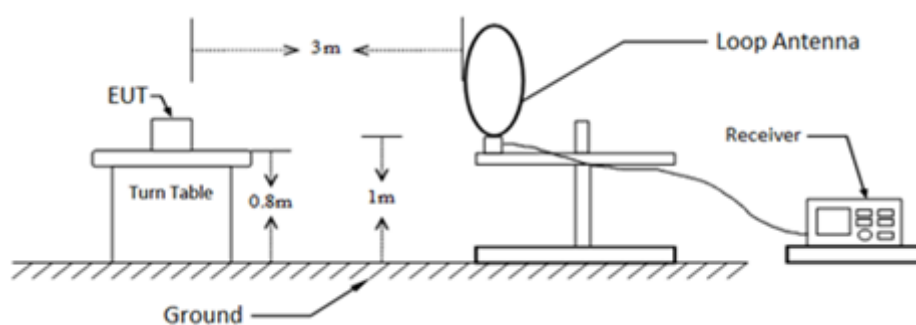

30MHz to 1 GHz:

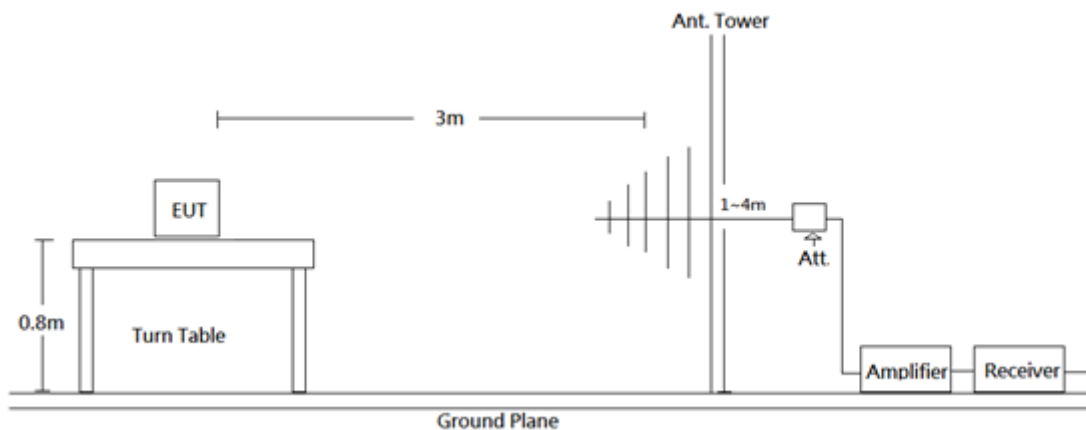

1-18 GHz:

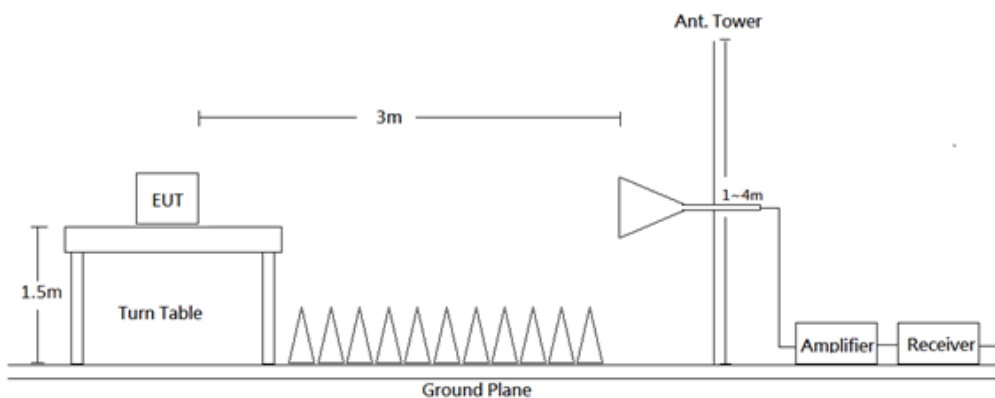

18-26.5 GHz:

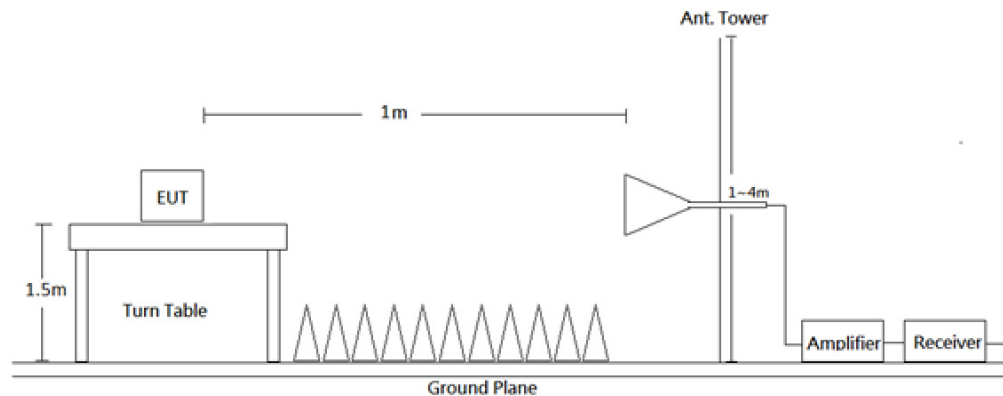

Radiated emission tests were performed in the 3 meters chamber test site, using the setup accordance with the ANSI C63.10-2013. The specification used was the FCC Part 15.209 and FCC 15.247 Limits.

8.3. EMI Test Receiver & Spectrum Analyzer Setup

The system was investigated from 9 kHz to 26.5 GHz. During the radiated emission test, the EMI test receiver was set with the following configurations measurement method 6.3 in ANSI C63.10.

Frequency Range	RBW	VBW	Measurement method
9 kHz - 150 kHz	300 Hz	1 kHz	QP/AV
150 kHz - 30 MHz	10 kHz	30 kHz	QP/AV
30-1000 MHz	120 kHz	/	QP
Above 1 GHz	1 MHz	3 MHz	PK
	1 MHz	10 Hz	Ave

If the maximized peak measured value complies with under the QP/Average limit more than 6dB, then it is unnecessary to perform an QP/Average measurement.

8.4. Test Procedure

Maximizing procedure was performed on the highest emissions to ensure that the EUT complied with all installation combinations.

All data was recorded in the Quasi-peak detector mode from 30 MHz to 1 GHz and PK and average detector modes for frequencies above 1 GHz.

8.5. Corrected Factor & Over Limit Calculation

The Correct Factor is calculated by adding the Antenna Factor and Cable Loss, and subtracting the Amplifier Gain from the Meter Reading. The basic equation is as follows:

$$\text{Correct Factor} = \text{Antenna Factor} + \text{Cable Loss} - \text{Amplifier Gain}$$

The “Over Limit” column of the following data tables indicates the degree of compliance with the applicable limit. For example, a margin of -7 dB means the emission is 7 dB below the limit. The equation for margin calculation is as follows:

$$\text{Over Limit} = \text{Result} - \text{Limit}$$

8.6. Test Results

Test Mode: Transmitting

(Loop Antenna Pre-scan with three orthogonal axis, and worse case as Y axis.)

9kHz-30MHz(worst case is BR(GFSK) mode middle channel)

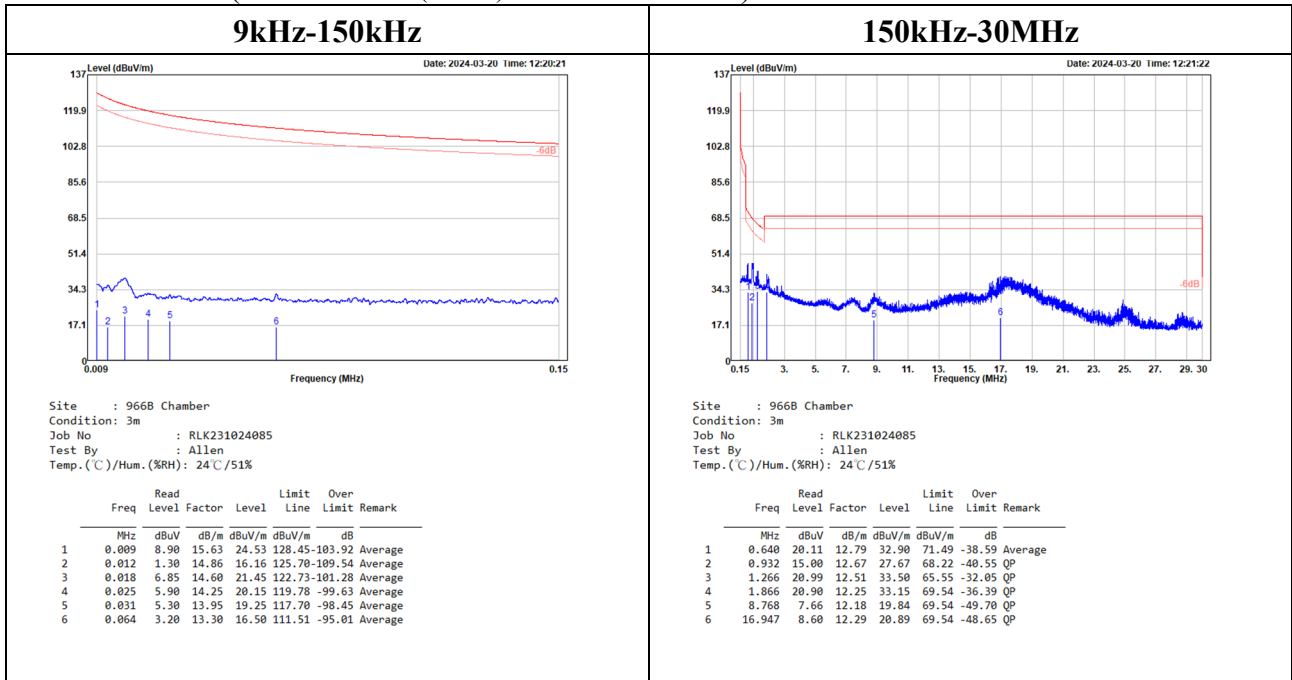

30MHz-1GHz:

Low channel

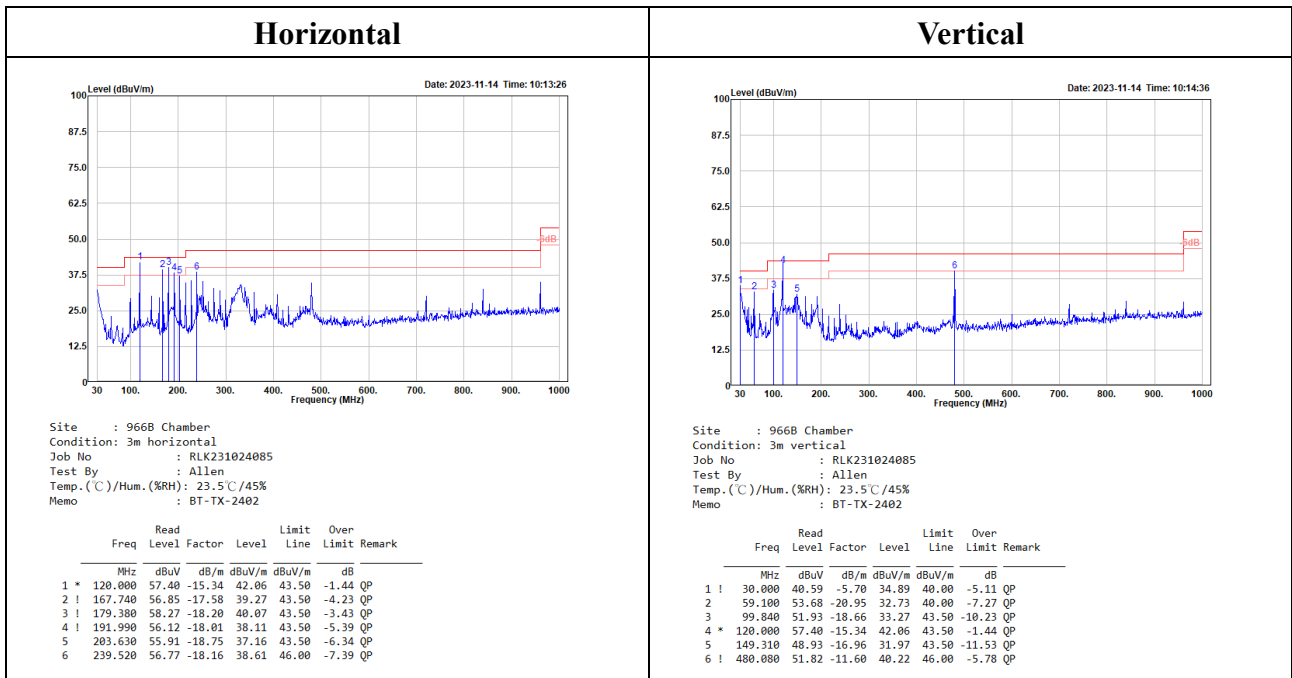

Middle channel

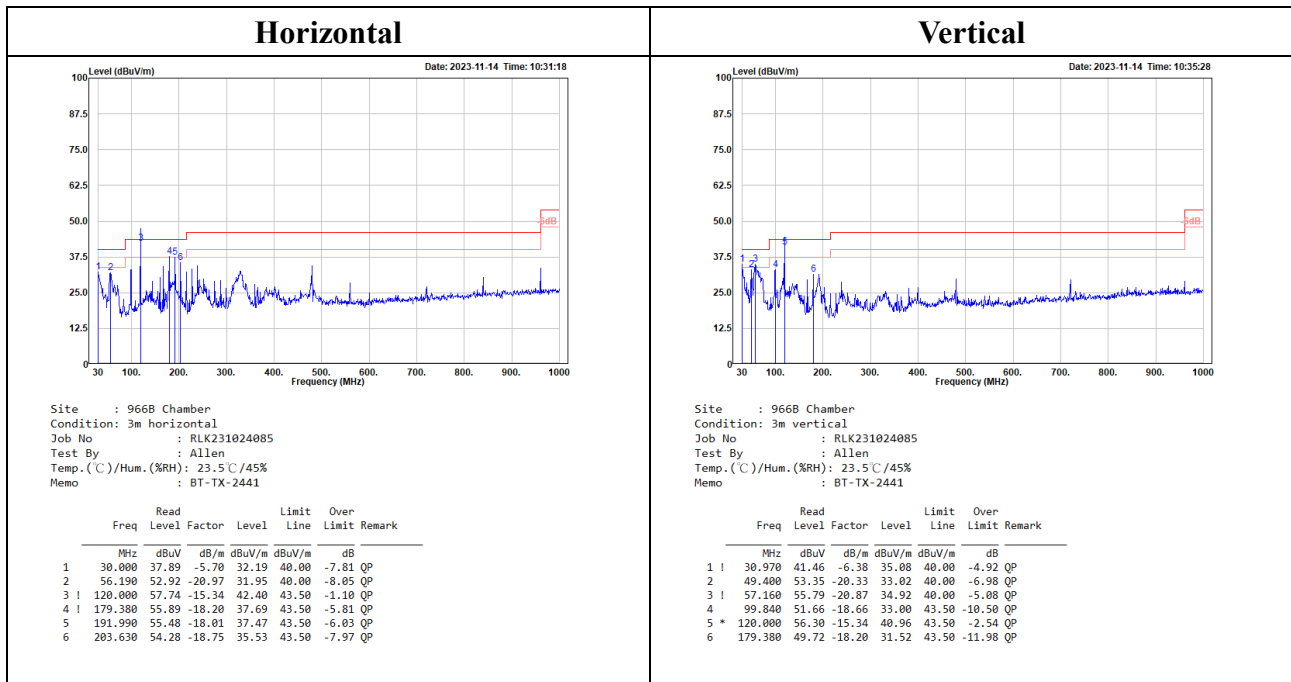

High channel

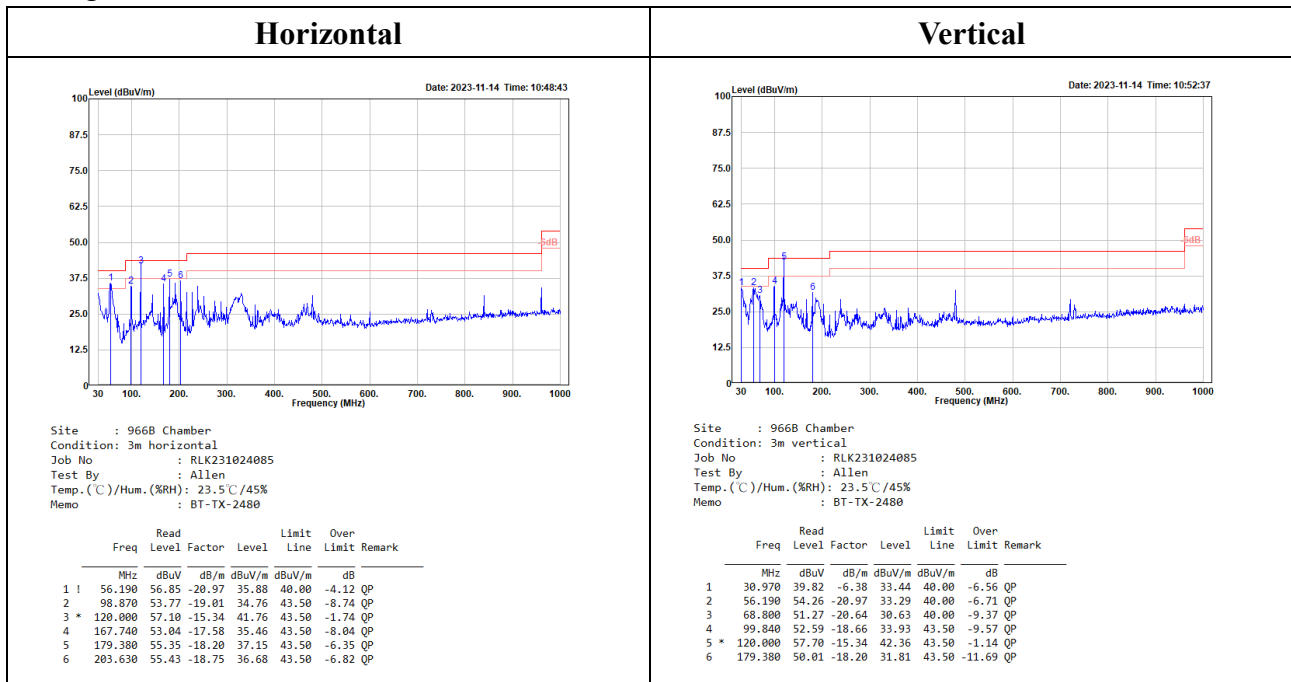

Level = Reading + Factor.

Over Limit = Level – Limit

Factor = Antenna Factor + Cable Loss – Amplifier Gain.

Spurious emissions more than 20 dB below the limit were not reported.