

TEST REPORT

Applicant: ShenZhen FLYSKY Technology Co.,Ltd
Address of Applicant: 16F, Huafeng Building, No. 6006 Shennan Road, Futian District, Shenzhen, Guangdong, China
Manufacturer: ShenZhen FLYSKY Technology Co.,Ltd
Address of Manufacturer: 16F, Huafeng Building, No. 6006 Shennan Road, Futian District, Shenzhen, Guangdong, China
Factory: Dongguan Flysky RC Model technology Co.,Ltd
Address of Factory: West building 3, Huangjinyuan Ind Park, Qiaoli North Gate, Changping Town, Dongguan, China

Equipment Under Test (EUT)

Product Name: 12-Channel Receiver
Model No.: Xr12
Trade Mark: FLYSKY
FCC ID: 2A2UNXR1200
Applicable standards: FCC CFR Title 47 Part 15 Subpart C Section 15.247
Date of sample receipt: October 14, 2024
Date of Test: October 15, 2024-November 07, 2024
Date of report issued: November 07, 2024
Test Result : PASS *

* In the configuration tested, the EUT complied with the standards specified above.

Authorized Signature:



Robinson Luo
Laboratory Manager

This results shown in this test report refer only to the sample(s) tested, this test report cannot be reproduced, except in full, without prior written permission of the company. The report would be invalid without specific stamp of test institute and the signatures of compiler and approver.

2 Version

Version No.	Date	Description
00	November 07, 2024	Original

Prepared By:

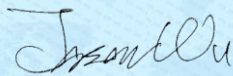

Date:

November 07, 2024

Project Engineer

Check By:

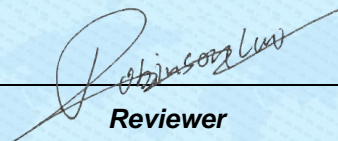

Reviewer

Date:

November 07, 2024

3 Contents

Page

1	COVER PAGE	1
2	VERSION	2
3	CONTENTS	3
4	TEST SUMMARY	4
4.1	MEASUREMENT UNCERTAINTY	4
5	GENERAL INFORMATION	5
5.1	GENERAL DESCRIPTION OF EUT	5
5.2	TEST MODE	7
5.3	TEST FACILITY.....	7
5.4	TEST LOCATION	7
5.5	DESCRIPTION OF SUPPORT UNITS	7
5.6	DEVIATION FROM STANDARDS.....	7
5.7	ABNORMALITIES FROM STANDARD CONDITIONS.....	7
5.8	ADDITIONAL INSTRUCTIONS.....	7
6	TEST INSTRUMENTS LIST	8
7	TEST RESULTS AND MEASUREMENT DATA.....	10
7.1	ANTENNA REQUIREMENT	10
7.2	CONDUCTED EMISSIONS	11
7.3	CONDUCTED PEAK OUTPUT POWER	14
7.4	CHANNEL BANDWIDTH	15
7.5	CARRIER FREQUENCIES SEPARATION.....	16
7.6	HOPPING CHANNEL NUMBER	17
7.7	DWELL TIME.....	18
7.8	SPURIOUS EMISSION.....	19
7.8.1	Conducted Emission Method.....	19
7.8.2	Radiated Emission Method.....	20
8	TEST SETUP PHOTO	35
9	EUT CONSTRUCTIONAL DETAILS	35

4 Test Summary

Test Item	Section	Result
Antenna Requirement	15.203	Pass
AC Power Line Conducted Emission	15.207	Pass
Conducted Peak Output Power	15.247 (b)(2)(3)	Pass
Channel Bandwidth	15.247 (a)(1)(2)	Pass
Carrier Frequencies Separation	15.247 (a)(1)	Pass
Hopping Channel Number	15.247 (a)(1)(iii)	Pass
Dwell Time	15.247(a)(1)(i)	Pass
Radiated Emission	15.205/15.209	Pass
Band Edge	15.247(d)	Pass

Pass: The EUT complies with the essential requirements in the standard.

Remark : Test according to ANSI C63.10:2013.

4.1 Measurement Uncertainty

No.	Item	Measurement Uncertainty
1	Radio Frequency	$\pm 7.25 \times 10^{-8}$
2	Duty cycle	$\pm 0.37\%$
3	Occupied Bandwidth	$\pm 3\%$
4	RF conducted power	$\pm 0.75\text{dB}$
5	RF power density	$\pm 3\text{dB}$
6	Conducted Spurious emissions	$\pm 2.58\text{dB}$
7	AC Power Line Conducted Emission	$\pm 3.44\text{dB}$ (0.15MHz~30MHz)
8	Radiated Spurious emission test	$\pm 3.1\text{dB}$ (9kHz-30MHz)
		$\pm 3.8039\text{dB}$ (30MHz-200MHz)
		$\pm 3.9679\text{dB}$ (200MHz-1GHz)
		$\pm 4.29\text{dB}$ (1GHz-18GHz)
		$\pm 3.30\text{dB}$ (18GHz-40GHz)
9	Temperature test	$\pm 1^\circ\text{C}$
10	Humidity test	$\pm 3\%$
11	Time	$\pm 3\%$

5 General Information

5.1 General Description of EUT

Product Name:	12-Channel Receiver
Model No.:	Xr12
Serial No.:	RD1001641
Test sample(s) ID:	GTS2024100126-1
Sample(s) Status	Engineer sample
Operation Frequency:	905.1MHz~926.4MHz
Channel numbers:	143
Modulation technology:	FHSS
Modulation type:	FLRC
Antenna Type:	Integral Antenna
Antenna gain:	0.84dBi(Declared by applicant)
Power supply:	DC 3.5-9V

Remark:

1. Antenna gain information provided by the customer
2. The relevant information of the sample is provided by the entrusting company, and the laboratory is not responsible for its authenticity.

The test frequencies are below:

Channel	Frequency(MHz)
The lowest channel	905.1
The middle channel	915.75
The Highest channel	926.4

Operation Frequency each of channel							
Channel	Frequency (MHz)	Channel	Frequency (MHz)	Channel	Frequency (MHz)	Channel	Frequency (MHz)
1	905.1	37	910.5	73	915.9	109	921.3
2	905.25	38	910.65	74	916.05	110	921.45
3	905.4	39	910.8	75	916.2	111	921.6
4	905.55	40	910.95	76	916.35	112	921.75
5	905.7	41	911.1	77	916.5	113	921.9
6	905.85	42	911.25	78	916.65	114	922.05
7	906	43	911.4	79	916.8	115	922.2
8	906.15	44	911.55	80	916.95	116	922.35
9	906.3	45	911.7	81	917.1	117	922.5
10	906.45	46	911.85	82	917.25	118	922.65
11	906.6	47	912	83	917.4	119	922.8
12	906.75	48	912.15	84	917.55	120	922.95
13	906.9	49	912.3	85	917.7	121	923.1
14	907.05	50	912.45	86	917.85	122	923.25
15	907.2	51	912.6	87	918	123	923.4
16	907.35	52	912.75	88	918.15	124	923.55
17	907.5	53	912.9	89	918.3	125	923.7
18	907.65	54	913.05	90	918.45	126	923.85
19	907.8	55	913.2	91	918.6	127	924
20	907.95	56	913.35	92	918.75	128	924.15
21	908.1	57	913.5	93	918.9	129	924.3
22	908.25	58	913.65	94	919.05	130	924.45
23	908.4	59	913.8	95	919.2	131	924.6
24	908.55	60	913.95	96	919.35	132	924.75
25	908.7	61	914.1	97	919.5	133	924.9
26	908.85	62	914.25	98	919.65	134	925.05
27	909	63	914.4	99	919.8	135	925.2
28	909.15	64	914.55	100	919.95	136	925.35
29	909.3	65	914.7	101	920.1	137	925.5
30	909.45	66	914.85	102	920.25	138	925.65
31	909.6	67	915	103	920.4	139	925.8
32	909.75	68	915.15	104	920.55	140	925.95
33	909.9	69	915.3	105	920.7	141	926.1
34	910.05	70	915.45	106	920.85	142	926.25
35	910.2	71	915.6	107	921	143	926.4
36	910.35	72	915.75	108	921.15		

5.2 Test mode

Transmitting mode	Keep the EUT in transmitting mode. New battery used
-------------------	---

5.3 Test Facility

<p>The test facility is recognized, certified, or accredited by the following organizations:</p> <ul style="list-style-type: none"> ● FCC —Registration No.: 381383 Designation Number: CN5029 Global United Technology Services Co., Ltd., Shenzhen EMC Laboratory has been registered and fully described in a report filed with the (FCC) Federal Communications Commission. The acceptance letter from the FCC is maintained in files. ● ISED —Registration No.: 9079A CAB identifier: CN0091 The 3m Semi-anechoic chamber of Global United Technology Services Co., Ltd. has been registered by Certification and Engineering Bureau of ISED for radio equipment testing. ● NVLAP (LAB CODE:600179-0) Global United Technology Services Co., Ltd., is accredited by the National Voluntary Laboratory Accreditation Program (NVLAP).

5.4 Test Location

All other tests were performed at:
<p>Global United Technology Services Co., Ltd. Address: No. 123-128, Tower A, Jinyuan Business Building, No.2, Laodong Industrial Zone, Xixiang Road, Baoan District, Shenzhen, Guangdong, China 518102 Tel: 0755-27798480 Fax: 0755-27798960</p>

5.5 Description of Support Units

Manufacturer	Description	Model	Serial Number
ShenZhen FLYSKY Technology Co.,Ltd	Remote control	SF-F6S	N/A
GW	DC POWER SUPPLY	GPR-6030D	EF924756

5.6 Deviation from Standards

None.

5.7 Abnormalities from Standard Conditions

None.

5.8 Additional Instructions

Test Software	Special test command provided by manufacturer
Power level setup	Default

6 Test Instruments list

Radiated Emission:						
Item	Test Equipment	Manufacturer	Model No.	Inventory No.	Cal.Date (mm-dd-yy)	Cal.Due date (mm-dd-yy)
1	3m Semi- Anechoic Chamber	ZhongYu Electron	9.2(L)*6.2(W)* 6.4(H)	GTS250	Jun. 22, 2024	Jun. 21, 2027
2	Control Room	ZhongYu Electron	6.2(L)*2.5(W)* 2.4(H)	GTS251	N/A	N/A
3	EMI Test Receiver	Rohde & Schwarz	ESU26	GTS203	Apr. 11, 2024	Apr. 10, 2025
4	BiConiLog Antenna	SCHWARZBECK MESS-ELEKTRONIK	VULB9168	GTS640	Mar. 19, 2023	Mar. 18, 2025
5	Double -ridged waveguide horn	SCHWARZBECK MESS-ELEKTRONIK	BBHA 9120 D	GTS208	Apr. 17, 2023	Apr. 16, 2025
6	EMI Test Software	AUDIX	E3	N/A	N/A	N/A
7	Wideband Radio Communication Tester	Rohde & Schwarz	CMW500	GTS575	Apr. 11, 2024	Apr. 10, 2025
8	Loop Antenna	ZHINAN	ZN30900A	GTS534	Nov. 13, 2023	Nov.12, 2024
9	Broadband Pre-amplifier	SCHWARZBECK	BBV9718	GTS535	Apr. 11, 2024	Apr. 10, 2025
10	Amplifier(1GHz-26.5GHz)	HP	8449B	GTS601	Apr. 11, 2024	Apr. 10, 2025
11	Horn Antenna (15GH-40GHz)	SCHWARZBECK	01296	GTS691	Mar. 07, 2024	Mar. 06, 2025
12	FSV·Signal Analyzer (10Hz-40GHz)	Keysight	FSV-40-N	GTS666	Mar. 12, 2024	Mar. 11, 2025
13	Amplifier	/	LNA-1000-30S	GTS650	Apr. 11, 2024	Apr. 10, 2025
14	CDNE M2+M3-16A	HCT	30MHz-300MHz	GTS692	Nov. 08, 2023	Nov. 07, 2024
15	Wideband Amplifier	/	WDA-01004000-15P35	GTS602	Apr. 11, 2024	Apr. 10, 2025
16	Thermo meter	JINCHUANG	GSP-8A	GTS643	Apr. 18, 2024	Apr. 17, 2025
17	RE cable 1	GTS	N/A	GTS675	Jul. 02, 2024	Jul. 01, 2025
18	RE cable 2	GTS	N/A	GTS676	Jul. 02, 2024	Jul. 01, 2025
19	RE cable 3	GTS	N/A	GTS677	Jul. 02, 2024	Jul. 01, 2025
20	RE cable 4	GTS	N/A	GTS678	Jul. 02, 2024	Jul. 01, 2025
21	RE cable 5	GTS	N/A	GTS679	Jul. 02, 2024	Jul. 01, 2025
22	RE cable 6	GTS	N/A	GTS680	Jul. 02, 2024	Jul. 01, 2025
23	RE cable 7	GTS	N/A	GTS681	Jul. 05, 2024	Jul. 04, 2025
24	RE cable 8	GTS	N/A	GTS682	Jul. 05, 2024	Jul. 04, 2025

Conducted Emission						
Item	Test Equipment	Manufacturer	Model No.	Inventory No.	Cal.Date (mm-dd-yy)	Cal.Due date (mm-dd-yy)
1	Shielding Room	ZhongYu Electron	7.3(L)x3.1(W)x2.9(H)	GTS252	Jul. 12, 2022	Jul. 11, 2027
2	EMI Test Receiver	R&S	ESCI 7	GTS552	Apr. 11, 2024	Apr. 10, 2025
3	LISN	ROHDE & SCHWARZ	ENV216	GTS226	Apr. 11, 2024	Apr. 10, 2025
4	Coaxial Cable	GTS	N/A	GTS227	N/A	N/A
5	EMI Test Software	AUDIX	E3	N/A	N/A	N/A
6	Thermo meter	JINCHUANG	GSP-8A	GTS642	Apr. 18, 2024	Apr. 17, 2025
7	Absorbing clamp	Elektronik-Feinmechanik	MDS21	GTS229	Apr. 11, 2024	Apr. 10, 2025
8	ISN	SCHWARZBECK	NTFM 8158	GTS565	Apr. 11, 2024	Apr. 10, 2025
9	High voltage probe	SCHWARZBECK	TK9420	GTS537	Apr. 11, 2024	Apr. 10, 2025
10	Antenna end assembly	Weinschel	1870A	GTS560	Apr. 11, 2024	Apr. 10, 2025

RF Conducted Test:						
Item	Test Equipment	Manufacturer	Model No.	Serial No.	Cal.Date (mm-dd-yy)	Cal.Due date (mm-dd-yy)
1	MXA Signal Analyzer	Agilent	N9020A	GTS566	Apr. 13, 2024	Apr. 12, 2025
2	EMI Test Receiver	R&S	ESCI 7	GTS552	Apr. 13, 2024	Apr. 12, 2025
3	PSA Series Spectrum Analyzer	Agilent	E4440A	GTS536	Apr. 13, 2024	Apr. 12, 2025
4	MXG vector Signal Generator	Agilent	N5182A	GTS567	Apr. 13, 2024	Apr. 12, 2025
5	ESG Analog Signal Generator	Agilent	E4428C	GTS568	Apr. 13, 2024	Apr. 12, 2025
6	USB RF Power Sensor	DARE	RPR3006W	GTS569	Apr. 13, 2024	Apr. 12, 2025
7	RF Switch Box	Shongyi	RFSW3003328	GTS571	Apr. 13, 2024	Apr. 12, 2025
8	Programmable Constant Temp & Humi Test Chamber	WEWON	WHTH-150L-40-880	GTS572	Apr. 13, 2024	Apr. 12, 2025
9	Thermo meter	JINCHUANG	GSP-8A	GTS641	Apr. 18, 2024	Apr. 17, 2025
10	EXA Signal Analyzer	Keysight	N9010B	MY60241168	Nov. 02, 2024	Nov. 01, 2025

General used equipment:						
Item	Test Equipment	Manufacturer	Model No.	Inventory No.	Cal.Date (mm-dd-yy)	Cal.Due date (mm-dd-yy)
1	Barometer	KUMAO	SF132	GTS647	Apr. 18, 2024	Apr. 17, 2025

7 Test results and Measurement Data

7.1 Antenna requirement

Standard requirement:	FCC Part15 C Section 15.203
15.203 requirement: An intentional radiator shall be designed to ensure that no antenna other than that furnished by the responsible party shall be used with the device. The use of a permanently attached antenna or of an antenna that uses a unique coupling to the intentional radiator, the manufacturer may design the unit so that a broken antenna can be replaced by the user, but the use of a standard antenna jack or electrical connector is prohibited.	
EUT Antenna:	
The antenna is integral antenna, reference to the appendix II for details.	

7.2 Conducted Emissions

Test Requirement:	FCC Part15 C Section 15.207					
Test Method:	ANSI C63.10:2013					
Test Frequency Range:	150KHz to 30MHz					
Class / Severity:	Class B					
Receiver setup:	RBW=9KHz, VBW=30KHz, Sweep time=auto					
Limit:	Frequency range (MHz)	Limit (dBuV)				
		Quasi-peak		Average		
	0.15-0.5	66 to 56*		56 to 46*		
	0.5-5	56		46		
	5-30	60		50		
* Decreases with the logarithm of the frequency.						
Test setup:	<p>Remark E.U.T: Equipment Under Test LISN: Line Impedance Stabilization Network Test table height=0.8m</p>					
Test procedure:	<ol style="list-style-type: none"> 1. The E.U.T and simulators are connected to the main power through a line impedance stabilization network (L.I.S.N.). This provides a 50ohm/50uH coupling impedance for the measuring equipment. 2. The peripheral devices are also connected to the main power through a LISN that provides a 50ohm/50uH coupling impedance with 50ohm termination. (Please refer to the block diagram of the test setup and photographs). 3. Both sides of A.C. line are checked for maximum conducted interference. In order to find the maximum emission, the relative positions of equipment and all of the interface cables must be changed according to ANSI C63.10:2013 on conducted measurement. 					
Test Instruments:	Refer to section 6.0 for details					
Test mode:	Refer to section 5.2 for details					
Test environment:	Temp.:	25 °C	Humid.:	52%	Press.:	1012mbar
Test results:	Pass					
Test voltage:	AC 120V					

Measurement data

Pre-scan all test modes, found worst case at 905.1MHz, and so only show the test result of it.

Line:

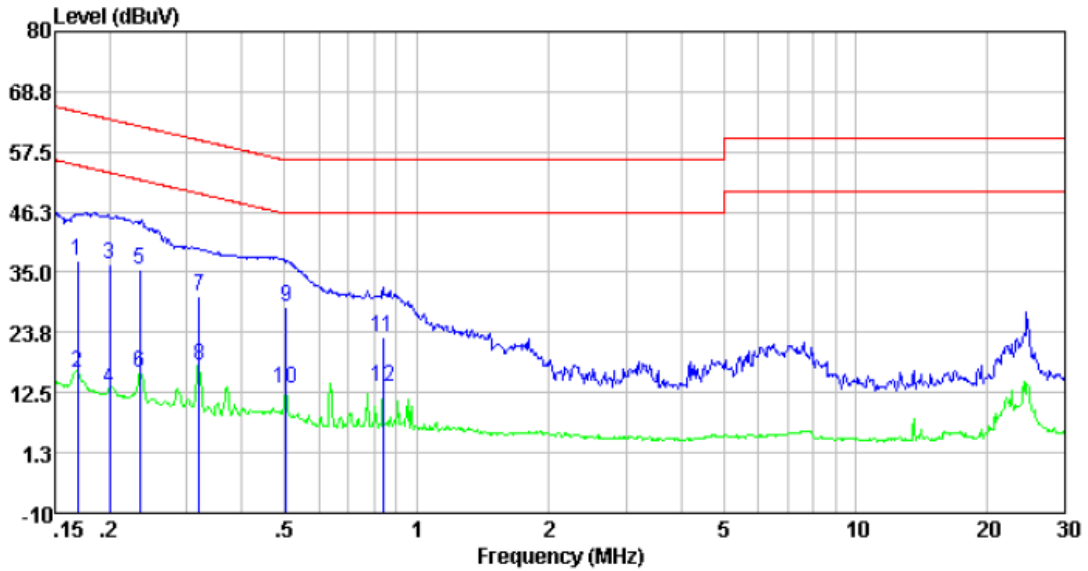

Freq	Reading level	LISN/ISN factor	Cable loss	Level	Limit level	Over limit	Remark
MHz	dBuV	dB	dB	dBuV	dBuV	dB	
0.17	27.33	9.89	0.01	37.23	65.03	-27.80	QP
0.17	6.48	9.89	0.01	16.38	55.03	-38.65	Average
0.20	27.00	9.54	0.01	36.55	63.62	-27.07	QP
0.20	3.81	9.54	0.01	13.36	53.62	-40.26	Average
0.23	25.82	9.58	0.01	35.41	62.30	-26.89	QP
0.23	6.80	9.58	0.01	16.39	52.30	-35.91	Average
0.32	20.99	9.64	0.01	30.64	59.71	-29.07	QP
0.32	8.07	9.64	0.01	17.72	49.71	-31.99	Average
0.50	18.69	9.86	0.01	28.56	56.00	-27.44	QP
0.50	3.29	9.86	0.01	13.16	46.00	-32.84	Average
0.84	13.10	9.74	0.03	22.87	56.00	-33.13	QP
0.84	3.83	9.74	0.03	13.60	46.00	-32.40	Average

Neutral:

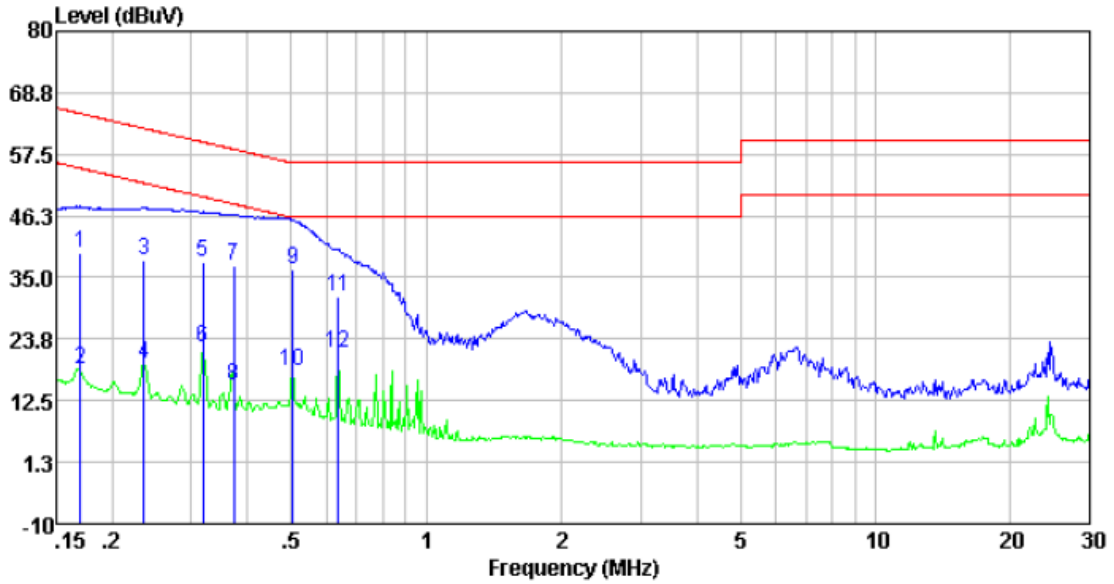

Freq	Reading level	LISN/ISN factor	Cable loss	Limit Level	Over limit	Remark
MHz	dBuV	dB	dB	dBuV	dB	
0.17	29.34	9.97	0.01	39.32	-25.67	QP
0.17	8.41	9.97	0.01	18.39	-36.60	Average
0.24	28.43	9.85	0.01	38.29	-23.97	QP
0.24	9.40	9.85	0.01	19.26	-33.00	Average
0.32	27.95	9.79	0.01	37.75	-22.00	QP
0.32	12.27	9.79	0.01	22.07	-27.68	Average
0.37	27.46	9.76	0.01	37.23	-21.20	QP
0.37	5.57	9.76	0.01	15.34	-33.09	Average
0.50	26.78	9.77	0.01	36.56	-19.44	QP
0.50	8.26	9.77	0.01	18.04	-27.96	Average
0.64	21.64	9.86	0.02	31.52	-24.48	QP
0.64	11.39	9.86	0.02	21.27	-24.73	Average

Notes:

1. An initial pre-scan was performed on the line and neutral lines with peak detector.
2. Quasi-Peak and Average measurement were performed at the frequencies with maximized peak emission.
3. Final Level = Receiver Read level + LISN Factor + Cable Loss
4. If the average limit is met when using a quasi-peak detector receiver, the EUT shall be deemed to meet both limits and measurement with the average detector receiver is unnecessary.

7.3 Conducted Peak Output Power

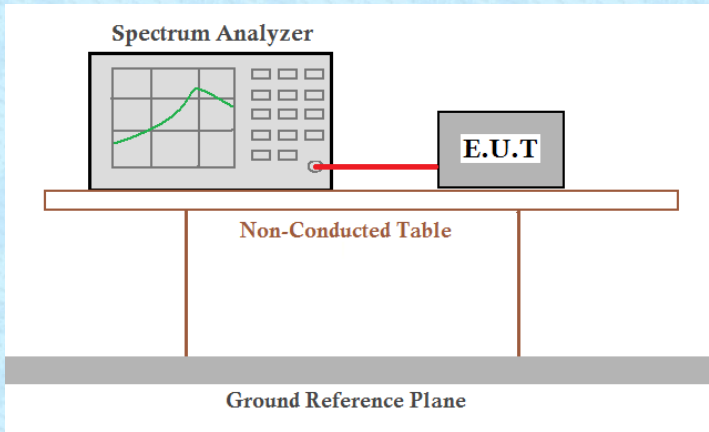
Test Requirement:	FCC Part15 C Section 15.247(b)(2)(3)
Test Method:	ANSI C63.10:2013
Limit:	30dBm
Test setup:	 <p>The diagram illustrates the test setup. A Spectrum Analyzer is connected to an E.U.T. (Equipment Under Test) via a red cable. Both are placed on a Non-Conducted Table, which sits on a Ground Reference Plane.</p>
Test Instruments:	Refer to section 6.0 for details
Test mode:	Refer to section 5.2 for details
Test results:	Pass

Measurement Data: The detailed test data see Appendix.

7.4 Channel Bandwidth

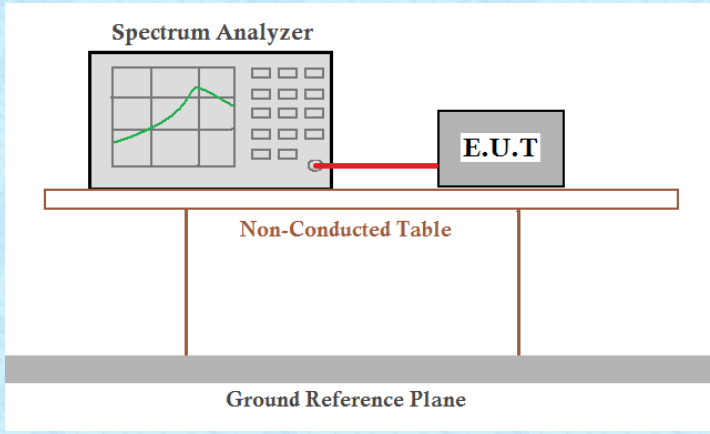
Test Requirement:	FCC Part15 C Section 15.247 (a)(1)(2)
Test Method:	ANSI C63.10:2013
Limit:	N/A
Test setup:	 <p>The diagram illustrates the test setup. A Spectrum Analyzer is connected to an E.U.T. (Equipment Under Test) via a red cable. Both are placed on a Non-Conducted Table, which is supported by a Ground Reference Plane.</p>
Test Instruments:	Refer to section 6.0 for details
Test mode:	Refer to section 5.2 for details
Test results:	Pass

Measurement Data: The detailed test data see Appendix.

7.5 Carrier Frequencies Separation

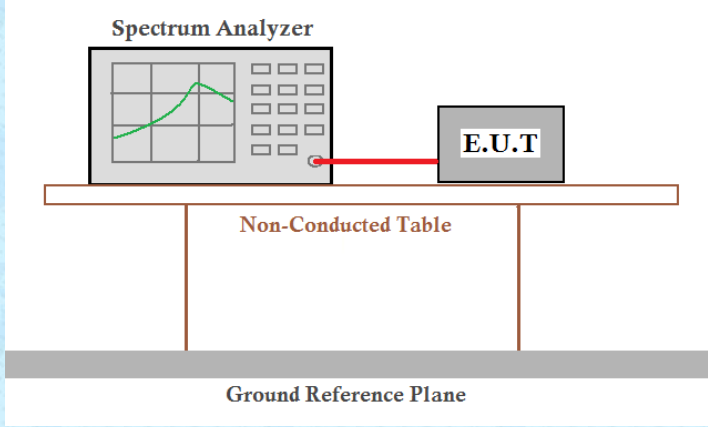
Test Requirement:	FCC Part15 C Section 15.247 (a)(1)
Test Method:	ANSI C63.10:2013
Receiver setup:	RBW=51KHz, VBW=150KHz, detector=Peak
Limit:	0.025MHz or 20dB bandwidth (whichever is greater)
Test setup:	 <p>The diagram illustrates the test setup. A Spectrum Analyzer is connected to an E.U.T. (Equipment Under Test) via a red cable. Both are placed on a Non-Conducted Table, which is supported by a Ground Reference Plane.</p>
Test Instruments:	Refer to section 6.0 for details
Test mode:	Refer to section 5.2 for details
Test results:	Pass

Measurement Data: The detailed test data see Appendix.

7.6 Hopping Channel Number

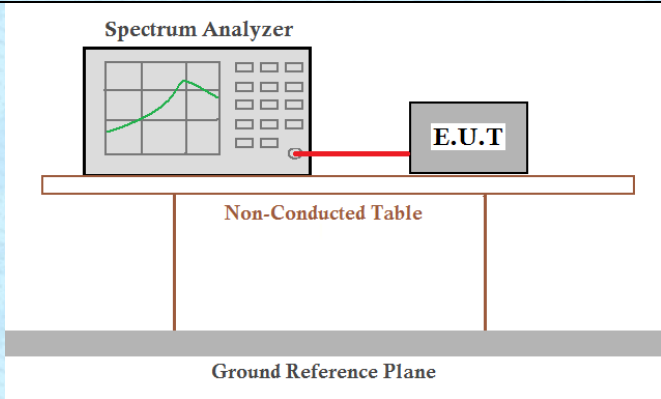
Test Requirement:	FCC Part15 C Section 15.247 (a)(1)(iii)
Test Method:	ANSI C63.10:2013
Receiver setup:	RBW=47kHz, VBW=150kHz, Frequency range=902MHz-928MHz, Detector=Peak
Limit:	Report for Use
Test setup:	 <p>The diagram illustrates the test setup. A Spectrum Analyzer is connected to an E.U.T. (Equipment Under Test) via a red cable. Both are placed on a Non-Conducted Table, which sits on a Ground Reference Plane.</p>
Test Instruments:	Refer to section 6.0 for details
Test mode:	Refer to section 5.2 for details
Test results:	Pass

Measurement Data: The detailed test data see Appendix.

7.7 Dwell Time

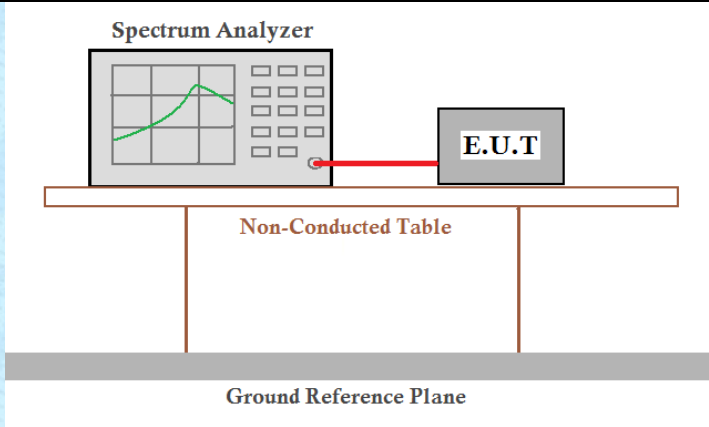
Test Requirement:	FCC Part15 C Section 15.247(a)(1)(i)
Test Method:	ANSI C63.10:2013
Receiver setup:	RBW=100KHz, VBW=100KHz, Span=0Hz, Detector=Peak
Limit:	0.4 Second
Test setup:	 <p>The diagram illustrates the test setup. A Spectrum Analyzer is connected to an E.U.T. (Equipment Under Test) via a red cable. Both are placed on a Non-Conducted Table, which is supported by a Ground Reference Plane.</p>
Test Instruments:	Refer to section 6.0 for details
Test mode:	Refer to section 5.2 for details
Test results:	Pass

Measurement Data: The detailed test data see Appendix.

7.8 Spurious Emission

7.8.1 Conducted Emission Method

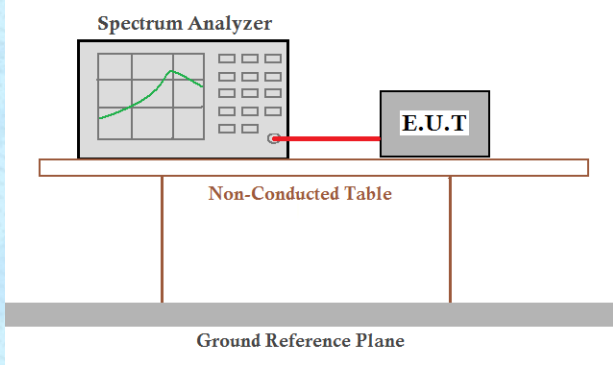
Test Requirement:	FCC Part15 C Section 15.247 (d)
Test Method:	ANSI C63.10:2013
Receiver setup:	RBW=100kHz, VBW=300kHz, Detector=Peak
Limit:	In any 100 kHz bandwidth outside the frequency band in which the spread spectrum intentional radiator is operating, the radio frequency power that is produced by the intentional radiator shall be at least 20 dB below that in the 100 kHz bandwidth within the band that contains the highest level of the desired power, based on either an RF conducted or a radiated measurement.
Test setup:	 <p>The diagram illustrates the test setup. A Spectrum Analyzer is connected to an E.U.T. (Equipment Under Test) via a red cable. Both are placed on a Non-Conducted Table, which sits on a Ground Reference Plane.</p>
Test Instruments:	Refer to section6.0 for details
Test mode:	Refer to section 5.2 for details
Test results:	Pass

Measurement Data: The detailed test data see Appendix.

7.8.2 Radiated Emission Method

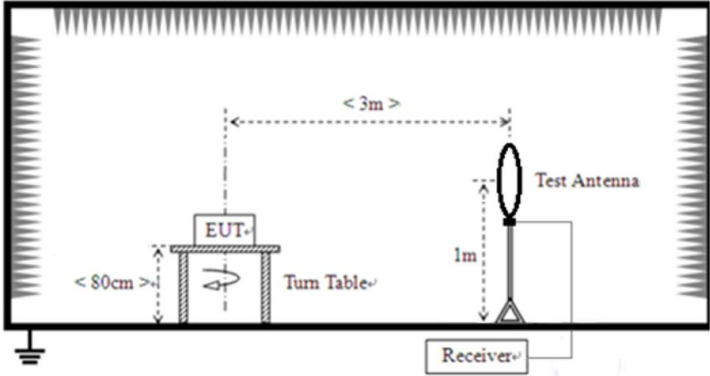
Test Requirement:	FCC Part15 C Section 15.209 and 15.205				
Test Method:	ANSI C63.10:2013				
Test Frequency Range:	9kHz to 18GHz				
Test site:	Measurement Distance: 3m				
Receiver setup:	Frequency	Detector	RBW	VBW	Value
	9KHz-150KHz	Quasi-peak	200Hz	600Hz	Quasi-peak
	150KHz-30MHz	Quasi-peak	9KHz	30KHz	Quasi-peak
	30MHz-1GHz	Quasi-peak	120KHz	300KHz	Quasi-peak
	Above 1GHz	Peak	1MHz	3MHz	Peak
Peak		1MHz	10Hz	Average	
Limit: (Spurious Emissions)	Frequency	Limit (uV/m)	Value	Measurement Distance	
	0.009MHz-0.490MHz	2400/F(KHz)	QP/PK/AV	300m	
	0.490MHz-1.705MHz	24000/F(KHz)	QP	300m	
	1.705MHz-30MHz	30	QP	30m	
	30MHz-88MHz	100	QP	3m	
	88MHz-216MHz	150	QP		
	216MHz-960MHz	200	QP		
	960MHz-1GHz	500	QP		
	Above 1GHz	500	Average		
5000		Peak			
Test setup:	Below 30MHz				
	 <p>Below 1GHz</p>				

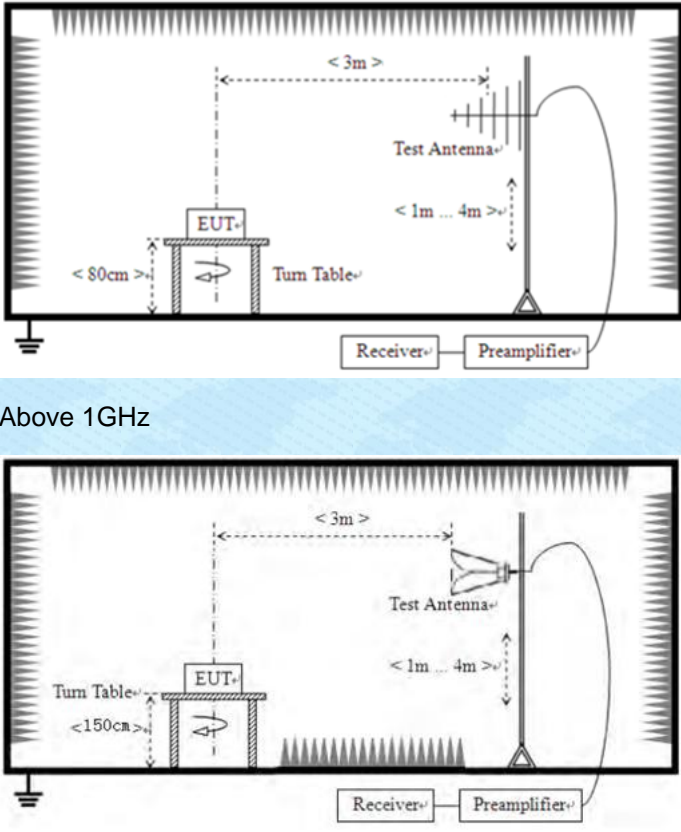
	 <p>Above 1GHz</p>						
<p>Test Procedure:</p>	<ol style="list-style-type: none"> 1. The EUT was placed on the top of a rotating table (0.8 meters for below 1GHz and 1.5meters for above 1GHz) above the ground at a 3 meter camber. The table was rotated 360 degrees to determine the position of the highest radiation. 2. The EUT was set 3 meters away from the interference-receiving antenna, which was mounted on the top of a variable-height antenna tower. 3. The antenna height is varied from one meter to four meters above the ground to determine the maximum value of the field strength. Both horizontal and vertical polarizations of the antenna are set to make the measurement. 4. For each suspected emission, the EUT was arranged to its worst case and then the antenna was tuned to heights from 1 meter to 4 meters and the rota table was turned from 0 degrees to 360 degrees to find the maximum reading. 5. The test-receiver system was set to Peak Detect Function and Specified Bandwidth with Maximum Hold Mode. 6. If the emission level of the EUT in peak mode was 10dB lower than the limit specified, then testing could be stopped and the peak values of the EUT would be reported. Otherwise the emissions that did not have 10dB margin would be re-tested one by one using peak, quasi-peak or average method as specified and then reported in a data sheet. 						
<p>Test Instruments:</p>	<p>Refer to section 5.8 for details</p>						
<p>Test mode:</p>	<p>Refer to section 5.2 for details</p>						
<p>Temp. / Hum.</p>	<table border="1"> <tr> <td>Temp.:</td> <td>25 °C</td> <td>Humid.:</td> <td>52%</td> <td>Press.:</td> <td>1 012mbar</td> </tr> </table>	Temp.:	25 °C	Humid.:	52%	Press.:	1 012mbar
Temp.:	25 °C	Humid.:	52%	Press.:	1 012mbar		

Test results:	Pass
Test voltage:	AC 120V

Remark:

1. *Pre-scan all kind of the place mode (X-axis, Y-axis, Z-axis), and found the Y-axis which it is worse case.*

Measurement data:

■ **Below 30MHz**

The low frequency, which started from 9 kHz to 30 MHz, was pre-scanned and the result which was 20 dB lower than the limit line per 15.31(o) was not reported.

■ 30MHz ~ 1GHz

Test channel:	Lowest	Polarization:	Horizontal
---------------	--------	---------------	------------

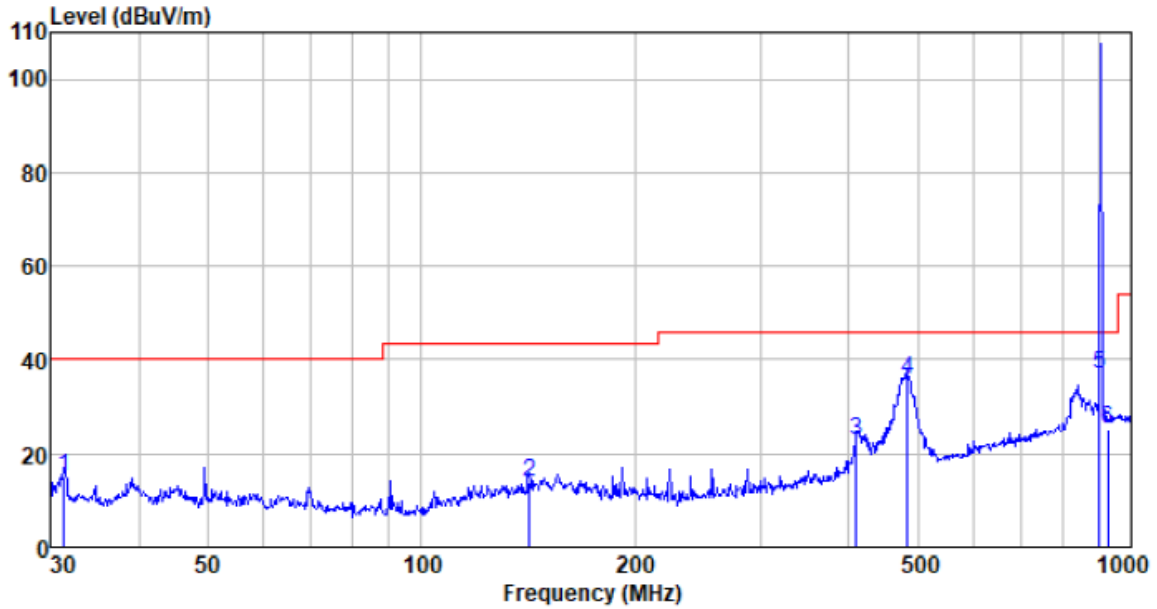

Freq MHz	Reading level dBuV	Antenna factor dB/m	Cable loss dB	Preamp factor dB	level dBuV/m	Limit level dBuV/m	Over limit dB	Remark
31.399	33.66	12.50	1.13	32.30	14.99	40.00	-25.01	QP
141.826	29.90	13.88	2.39	32.46	13.71	43.50	-29.79	QP
410.383	36.19	15.01	3.92	32.24	22.88	46.00	-23.12	QP
483.910	47.34	16.50	4.14	32.21	35.77	46.00	-10.23	QP
902.000	39.35	23.10	5.74	31.10	37.09	46.00	-8.91	QP
928.000	27.15	23.36	5.81	31.10	25.22	46.00	-20.78	QP

Test channel:	Lowest	Polarization:	Vertical
---------------	--------	---------------	----------

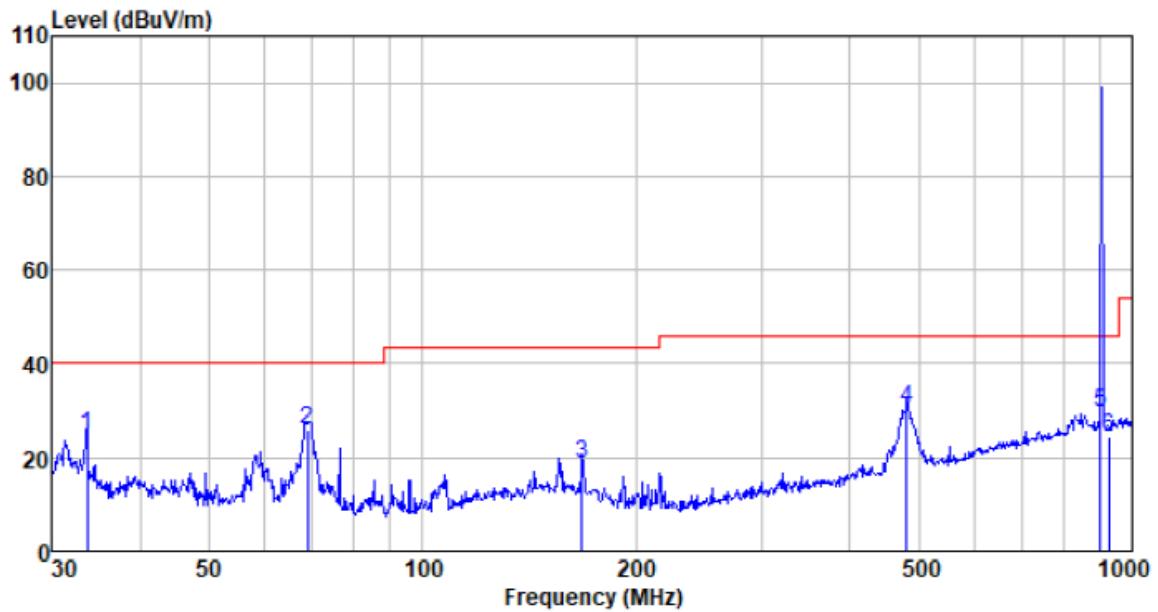

Freq MHz	Reading level dBuV	Antenna factor dB/m	Cable loss dB	Preamp factor dB	level dBuV/m	Limit level dBuV/m	Over limit dB	Remark
33.680	43.10	12.74	1.16	32.30	24.70	40.00	-15.30	QP
68.872	45.62	10.91	1.63	32.38	25.78	40.00	-14.22	QP
167.824	35.01	13.62	2.62	32.43	18.82	43.50	-24.68	QP
480.528	42.00	16.50	4.13	32.21	30.42	46.00	-15.58	QP
902.000	31.77	23.10	5.74	31.10	29.51	46.00	-16.49	QP
928.000	26.30	23.36	5.81	31.10	24.37	46.00	-21.63	QP

Test channel:	Middle	Polarization:	Horizontal
---------------	--------	---------------	------------

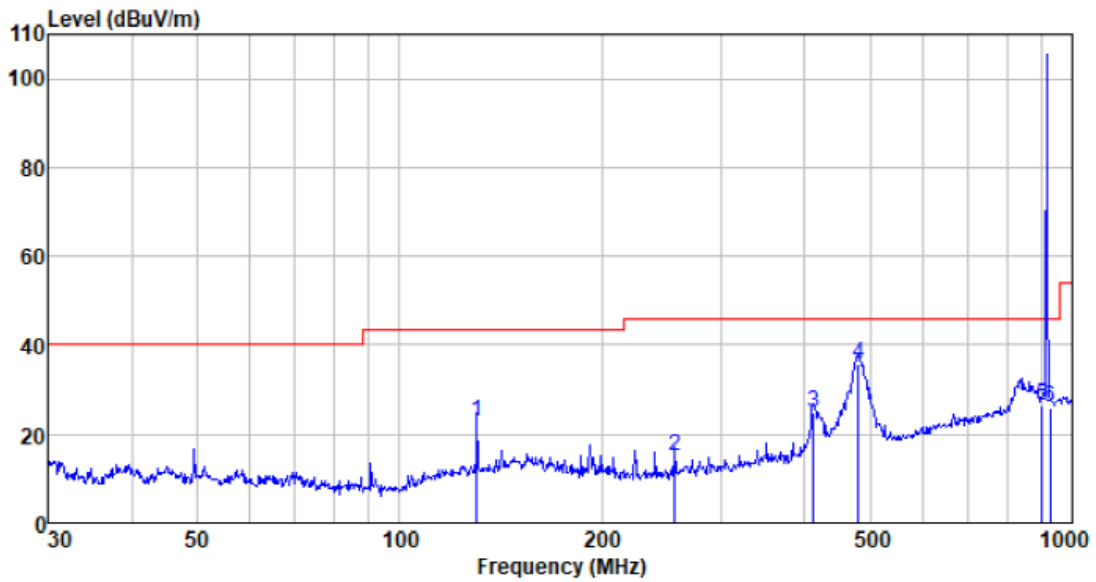

Freq MHz	Reading level dBuV	Antenna factor dB/m	Cable loss dB	Preamp factor dB	level dBuV/m	Limit level dBuV/m	Over limit dB	Remark
130.379	39.75	13.24	2.28	32.47	22.80	43.50	-20.70	QP
256.521	33.57	10.76	3.20	32.34	15.19	46.00	-30.81	QP
411.824	38.17	15.04	3.92	32.24	24.89	46.00	-21.11	QP
480.528	47.41	16.50	4.13	32.21	35.83	46.00	-10.17	QP
902.000	28.78	23.10	5.74	31.10	26.52	46.00	-19.48	QP
928.000	28.02	23.36	5.81	31.10	26.09	46.00	-19.91	QP

Test channel:	Middle	Polarization:	Vertical
---------------	--------	---------------	----------

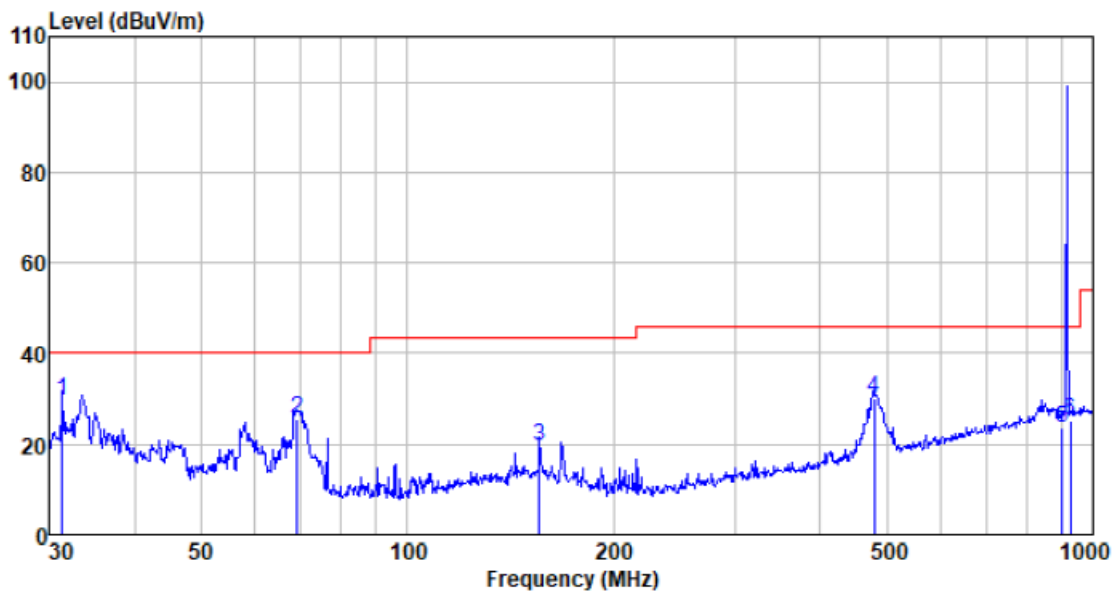

Freq MHz	Reading level dBuV	Antenna factor dB/m	Cable loss dB	Preamp factor dB	level dBuV/m	Limit level dBuV/m	Over limit dB	Remark
31.399	48.19	12.50	1.13	32.30	29.52	40.00	-10.48	QP
69.114	45.46	10.89	1.64	32.38	25.61	40.00	-14.39	QP
155.910	34.67	14.80	2.52	32.44	19.55	43.50	-23.95	QP
478.846	41.66	16.48	4.13	32.21	30.06	46.00	-15.94	QP
902.000	25.95	23.10	5.74	31.10	23.69	46.00	-22.31	QP
928.000	26.90	23.36	5.81	31.10	24.97	46.00	-21.03	QP

Test channel:	Highest	Polarization:	Horizontal
---------------	---------	---------------	------------

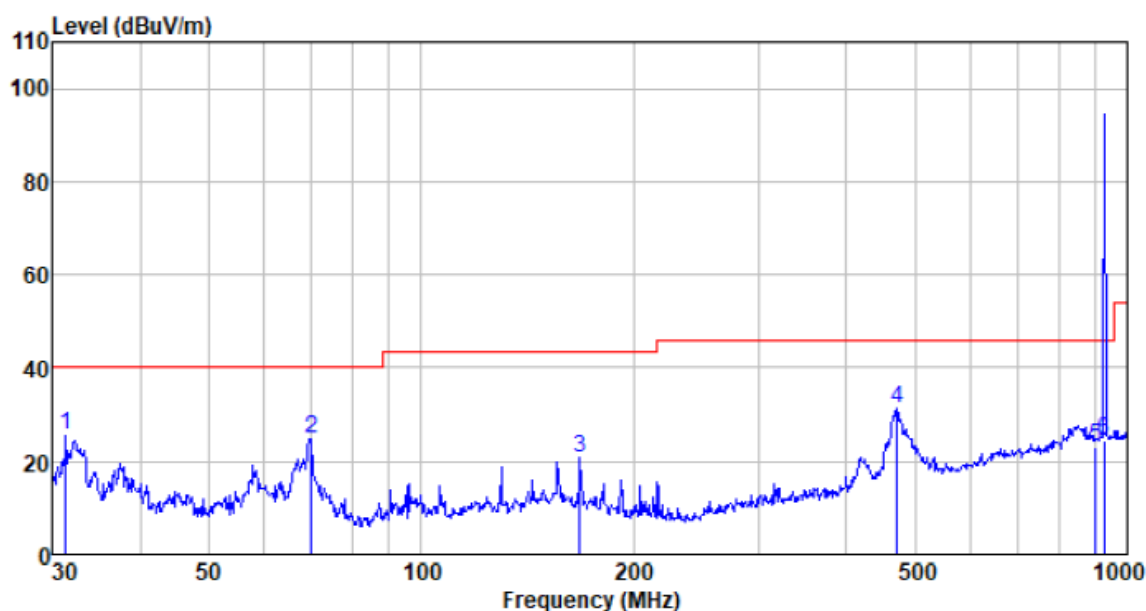

Freq MHz	Reading level dBuV	Antenna factor dB/m	Cable loss dB	Preamp factor dB	level dBuV/m	Limit level dBuV/m	Over limit dB	Remark
31.399	44.42	12.50	1.13	32.30	25.75	40.00	-14.25	QP
69.845	44.86	10.82	1.65	32.38	24.95	40.00	-15.05	QP
167.824	36.98	13.62	2.62	32.43	20.79	43.50	-22.71	QP
472.176	42.89	16.34	4.11	32.21	31.13	46.00	-14.87	QP
902.000	25.22	23.10	5.74	31.10	22.96	46.00	-23.04	QP
928.000	26.30	23.36	5.81	31.10	24.37	46.00	-21.63	QP

Test channel:	Highest	Polarization:	Vertical
---------------	---------	---------------	----------

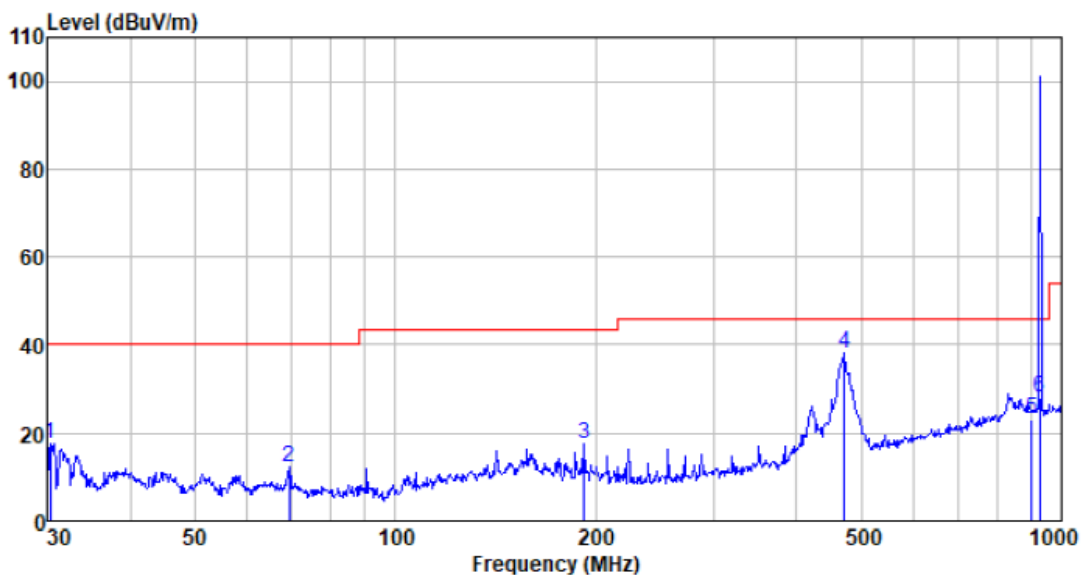

Freq MHz	Reading level dBuV	Antenna factor dB/m	Cable loss dB	Preamp factor dB	level dBuV/m	Limit level dBuV/m	Over limit dB	Remark
30.317	36.16	12.43	1.11	32.30	17.40	40.00	-22.60	QP
69.357	32.06	10.86	1.64	32.38	12.18	40.00	-27.82	QP
191.745	36.40	10.63	2.79	32.41	17.41	43.50	-26.09	QP
472.176	49.73	16.34	4.11	32.21	37.97	46.00	-8.03	QP
902.000	25.56	23.10	5.74	31.10	23.30	46.00	-22.70	QP
928.000	30.10	23.36	5.81	31.10	28.17	46.00	-17.83	QP

■ Above 1GHz

Test channel:	Lowest	Polarization:	Horizontal
---------------	--------	---------------	------------

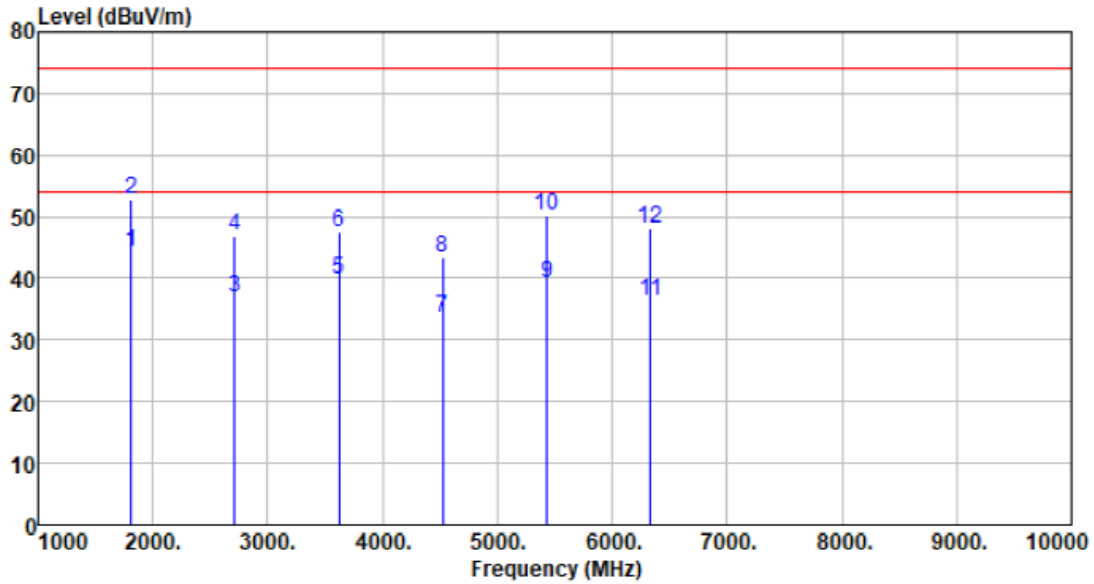

Freq MHz	Reading level dBuV	Antenna factor dB/m	Cable loss dB	Preamp factor dB	level dBuV/m	Limit level dBuV/m	Over limit dB	Remark
1810.200	53.34	25.04	4.64	38.86	44.16	54.00	-9.84	Average
1810.200	62.13	25.04	4.64	38.86	52.95	74.00	-21.05	Peak
2715.300	44.18	27.96	4.16	39.34	36.96	54.00	-17.04	Average
2715.300	54.07	27.96	4.16	39.34	46.85	74.00	-27.15	Peak
3620.400	43.84	29.54	4.98	38.60	39.76	54.00	-14.24	Average
3620.400	51.72	29.54	4.98	38.60	47.64	74.00	-26.36	Peak
4525.500	34.79	31.55	5.78	38.59	33.53	54.00	-20.47	Average
4525.500	44.67	31.55	5.78	38.59	43.41	74.00	-30.59	Peak
5430.600	38.93	32.66	6.37	38.59	39.37	54.00	-14.63	Average
5430.600	49.79	32.66	6.37	38.59	50.23	74.00	-23.77	Peak
6335.700	33.56	34.17	7.39	38.93	36.19	54.00	-17.81	Average
6335.700	45.63	34.17	7.39	38.93	48.26	74.00	-25.74	Peak

Test channel:	Lowest	Polarization:	Vertical
---------------	--------	---------------	----------

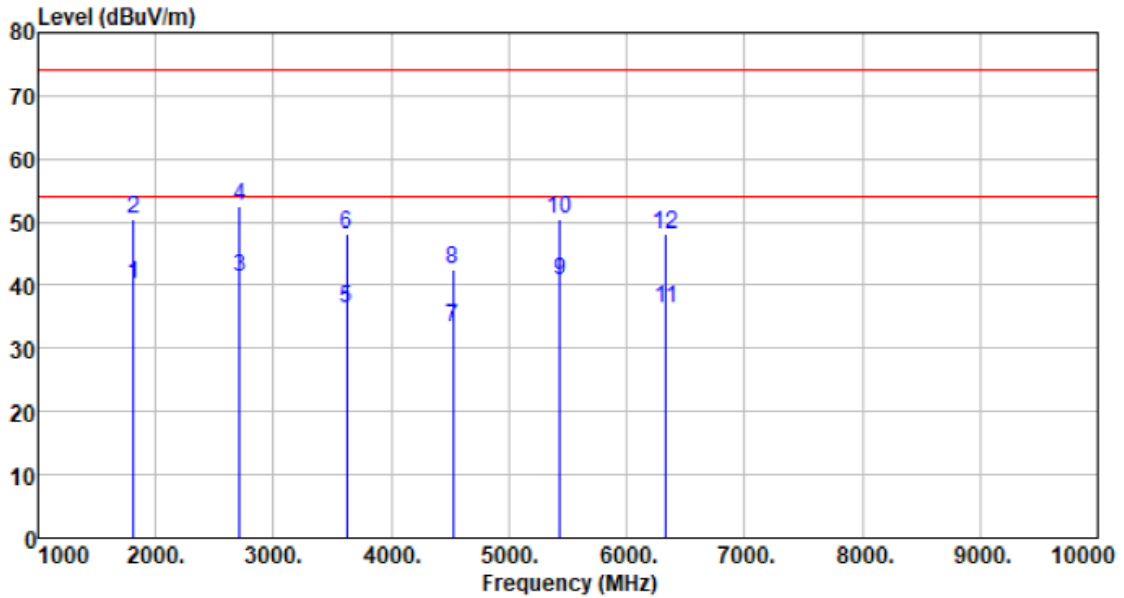

Freq MHz	Reading level dBuV	Antenna factor dB/m	Cable loss dB	Preamp factor dB	level dBuV/m	Limit level dBuV/m	Over limit dB	Remark
1810.200	49.42	25.04	4.64	38.86	40.24	54.00	-13.76	Average
1810.200	59.55	25.04	4.64	38.86	50.37	74.00	-23.63	Peak
2715.300	48.69	27.96	4.16	39.34	41.47	54.00	-12.53	Average
2715.300	59.89	27.96	4.16	39.34	52.67	74.00	-21.33	Peak
3620.400	40.27	29.54	4.98	38.60	36.19	54.00	-17.81	Average
3620.400	52.07	29.54	4.98	38.60	47.99	74.00	-26.01	Peak
4525.500	34.65	31.55	5.78	38.59	33.39	54.00	-20.61	Average
4525.500	43.82	31.55	5.78	38.59	42.56	74.00	-31.44	Peak
5430.600	40.25	32.66	6.37	38.59	40.69	54.00	-13.31	Average
5430.600	50.18	32.66	6.37	38.59	50.62	74.00	-23.38	Peak
6335.700	33.75	34.17	7.39	38.93	36.38	54.00	-17.62	Average
6335.700	45.63	34.17	7.39	38.93	48.26	74.00	-25.74	Peak

Test channel:	Middle	Polarization:	Horizontal
---------------	--------	---------------	------------

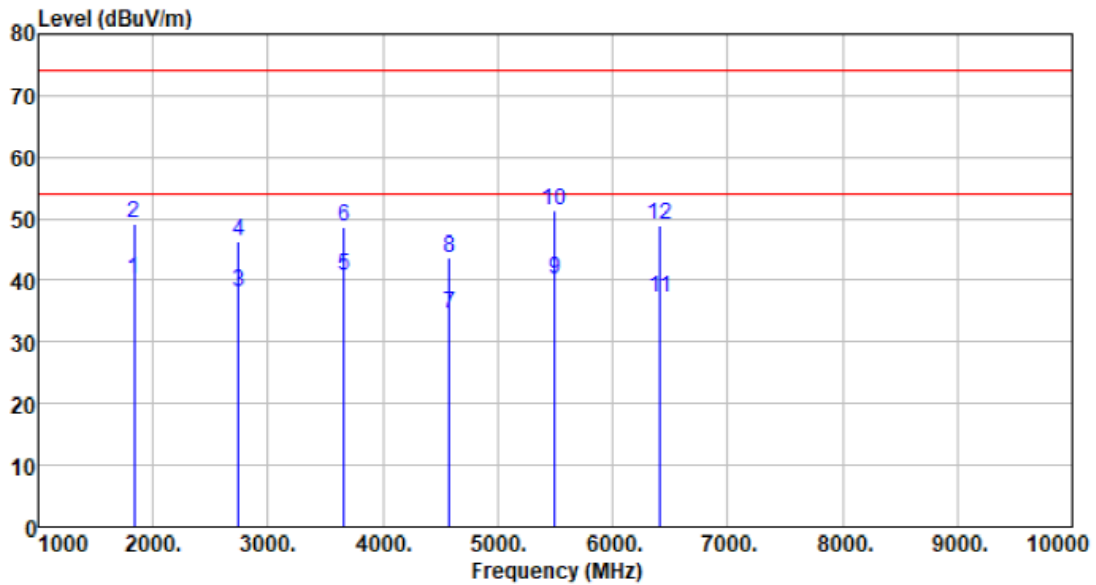

Freq MHz	Reading level dBuV	Antenna factor dB/m	Cable loss dB	Preamp factor dB	level dBuV/m	Limit level dBuV/m	Over limit dB	Remark
1831.500	49.26	25.13	4.60	38.80	40.19	54.00	-13.81	Average
1831.500	58.31	25.13	4.60	38.80	49.24	74.00	-24.76	Peak
2747.250	45.19	28.09	4.22	39.30	38.20	54.00	-15.80	Average
2747.250	53.33	28.09	4.22	39.30	46.34	74.00	-27.66	Peak
3663.000	44.80	29.63	5.01	38.57	40.87	54.00	-13.13	Average
3663.000	52.63	29.63	5.01	38.57	48.70	74.00	-25.30	Peak
4578.750	35.62	31.66	5.87	38.58	34.57	54.00	-19.43	Average
4578.750	44.80	31.66	5.87	38.58	43.75	74.00	-30.25	Peak
5494.500	39.45	32.79	6.42	38.60	40.06	54.00	-13.94	Average
5494.500	50.68	32.79	6.42	38.60	51.29	74.00	-22.71	Peak
6410.250	34.49	34.34	7.40	38.94	37.29	54.00	-16.71	Average
6410.250	46.27	34.34	7.40	38.94	49.07	74.00	-24.93	Peak

Test channel:	Middle	Polarization:	Vertical
---------------	--------	---------------	----------

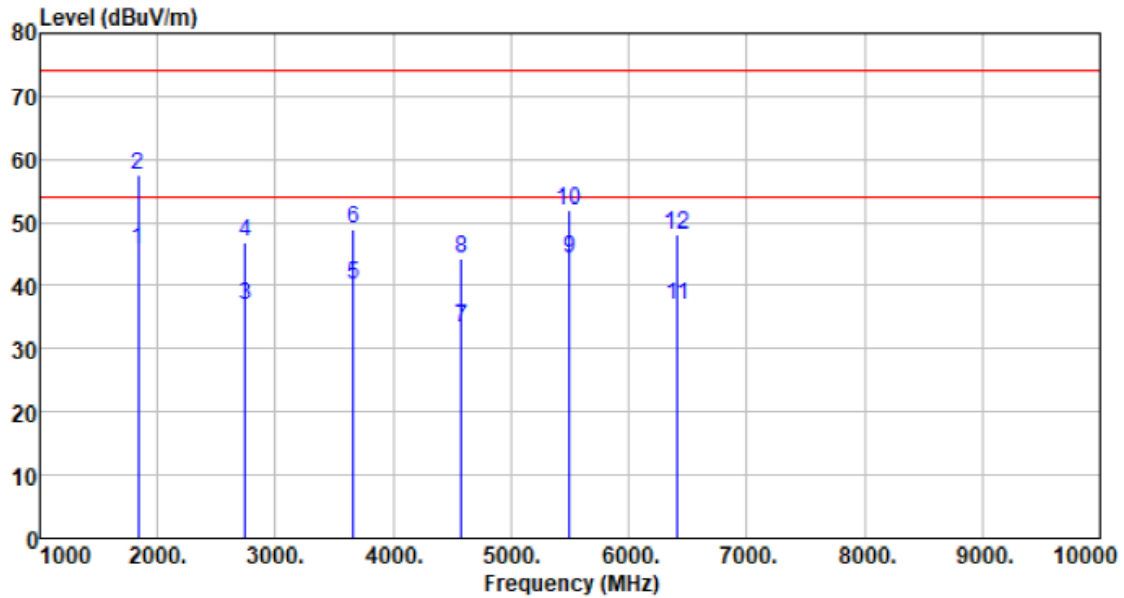

Freq MHz	Reading level dBuV	Antenna factor dB/m	Cable loss dB	Preamp factor dB	level dBuV/m	Limit level dBuV/m	Over limit dB	Remark
1831.500	54.71	25.13	4.60	38.80	45.64	54.00	-8.36	Average
1831.500	66.56	25.13	4.60	38.80	57.49	74.00	-16.51	Peak
2747.250	43.87	28.09	4.22	39.30	36.88	54.00	-17.12	Average
2747.250	53.94	28.09	4.22	39.30	46.95	74.00	-27.05	Peak
3663.000	43.95	29.63	5.01	38.57	40.02	54.00	-13.98	Average
3663.000	52.89	29.63	5.01	38.57	48.96	74.00	-25.04	Peak
4578.750	34.53	31.66	5.87	38.58	33.48	54.00	-20.52	Average
4578.750	45.26	31.66	5.87	38.58	44.21	74.00	-29.79	Peak
5494.500	43.68	32.79	6.42	38.60	44.29	54.00	-9.71	Average
5494.500	51.49	32.79	6.42	38.60	52.10	74.00	-21.90	Peak
6410.250	34.16	34.34	7.40	38.94	36.96	54.00	-17.04	Average
6410.250	45.34	34.34	7.40	38.94	48.14	74.00	-25.86	Peak

Test channel:	Highest	Polarization:	Horizontal
---------------	---------	---------------	------------

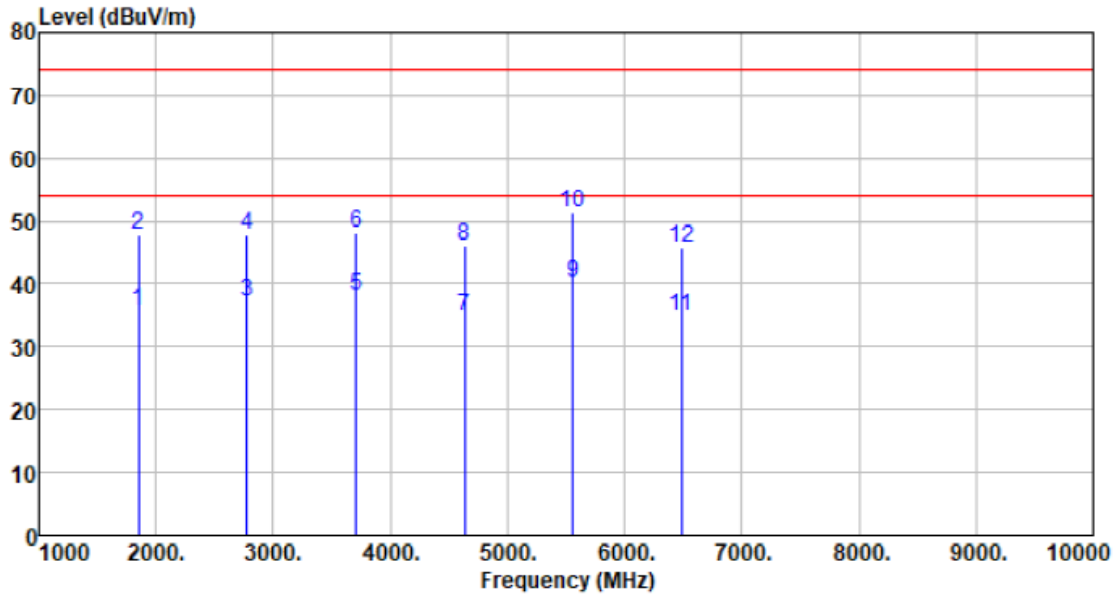

Freq MHz	Reading level dBuV	Antenna factor dB/m	Cable loss dB	Preamp factor dB	level dBuV/m	Limit level dBuV/m	Over limit dB	Remark
1852.800	44.68	25.21	4.56	38.75	35.70	54.00	-18.30	Average
1852.800	56.82	25.21	4.56	38.75	47.84	74.00	-26.16	Peak
2779.200	43.88	28.22	4.28	39.26	37.12	54.00	-16.88	Average
2779.200	54.64	28.22	4.28	39.26	47.88	74.00	-26.12	Peak
3705.600	41.87	29.71	5.03	38.54	38.07	54.00	-15.93	Average
3705.600	51.98	29.71	5.03	38.54	48.18	74.00	-25.82	Peak
4632.000	35.65	31.76	5.93	38.57	34.77	54.00	-19.23	Average
4632.000	46.83	31.76	5.93	38.57	45.95	74.00	-28.05	Peak
5558.400	39.47	32.92	6.47	38.64	40.22	54.00	-13.78	Average
5558.400	50.65	32.92	6.47	38.64	51.40	74.00	-22.60	Peak
6484.800	31.73	34.64	7.43	38.95	34.85	54.00	-19.15	Average
6484.800	42.60	34.64	7.43	38.95	45.72	74.00	-28.28	Peak

Test channel:	Highest	Polarization:	Vertical
---------------	---------	---------------	----------

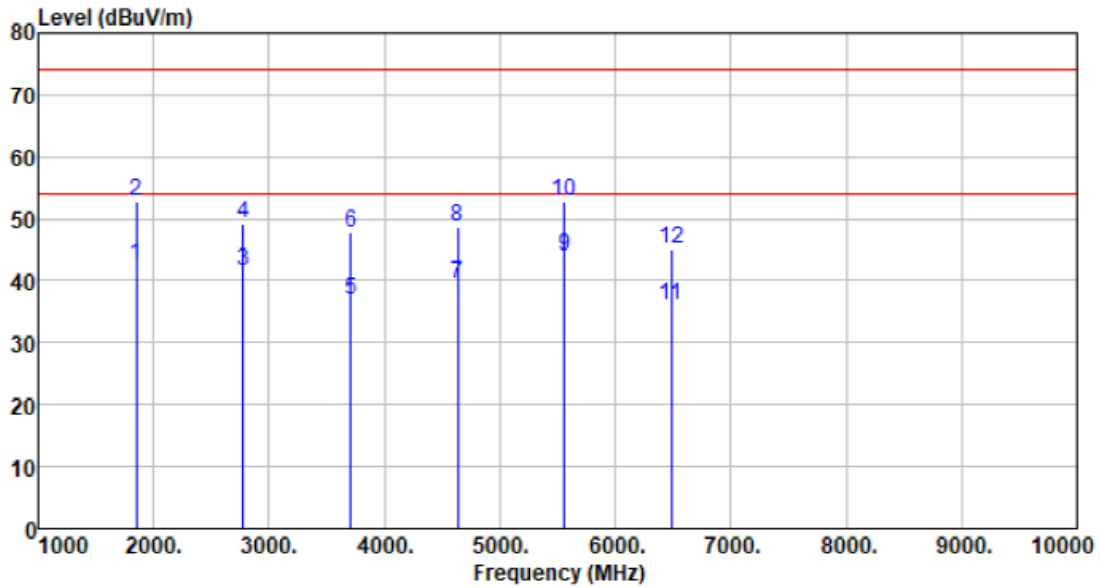

Freq MHz	Reading level dBuV	Antenna factor dB/m	Cable loss dB	Preamp factor dB	level dBuV/m	Limit level dBuV/m	Over limit dB	Remark
1852.800	51.44	25.21	4.56	38.75	42.46	54.00	-11.54	Average
1852.800	61.69	25.21	4.56	38.75	52.71	74.00	-21.29	Peak
2779.200	48.25	28.22	4.28	39.26	41.49	54.00	-12.51	Average
2779.200	56.09	28.22	4.28	39.26	49.33	74.00	-24.67	Peak
3705.600	40.57	29.71	5.03	38.54	36.77	54.00	-17.23	Average
3705.600	51.77	29.71	5.03	38.54	47.97	74.00	-26.03	Peak
4632.000	40.31	31.76	5.93	38.57	39.43	54.00	-14.57	Average
4632.000	49.46	31.76	5.93	38.57	48.58	74.00	-25.42	Peak
5558.400	43.30	32.92	6.47	38.64	44.05	54.00	-9.95	Average
5558.400	52.20	32.92	6.47	38.64	52.95	74.00	-21.05	Peak
6484.800	33.03	34.64	7.43	38.95	36.15	54.00	-17.85	Average
6484.800	42.16	34.64	7.43	38.95	45.28	74.00	-28.72	Peak

Remark:

1. Final Level = Receiver Read level + Antenna Factor + Cable Loss – Preamplifier Factor
2. The emission levels of other frequencies are very lower than the limit and not show in test report.

8 Test Setup Photo

Reference to the **appendix I** for details.

9 EUT Constructional Details

Reference to the **appendix II** for details.

---End---