

TEST REPORT

Applicant: ShenZhen FLYSKY Technology Co.,Ltd

Address of Applicant: 16F, Huafeng Building, No. 6006 Shennan Road, Futian District, Shenzhen, Guangdong, China

Manufacturer: ShenZhen FLYSKY Technology Co.,Ltd

Address of Manufacturer: 16F, Huafeng Building, No. 6006 Shennan Road, Futian District, Shenzhen, Guangdong, China

Factory: Dongguan Flysky RC Model technology Co.,Ltd

Address of Factory: West building 3, HuangjinyuanInd Park, Qiaoli North Gate, Changping Town, Dongguan, China

Equipment Under Test (EUT)

Product Name: 12-Channel Receiver

Model No.: Xr12

Trade Mark: FLYSKY

FCC ID: 2A2UNXR1200

Applicable standards: FCC CFR Title 47 Part 15 Subpart C Section 15.247

Date of sample receipt: October 14, 2024

Date of Test: October 15, 2024-November 07, 2024

Date of report issued: November 07, 2024

Test Result : PASS *

* In the configuration tested, the EUT complied with the standards specified above.

Authorized Signature:



Robinson Luo
Laboratory Manager

2 Version

Version No.	Date	Description
00	November 07, 2024	Original

Prepared By:

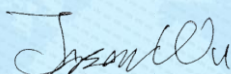

Date:

November 07, 2024

Project Engineer

Check By:

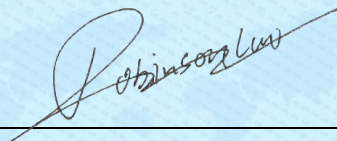

Date:

November 07, 2024

Reviewer

3 Contents

Page

1	COVER PAGE	1
2	VERSION	2
3	CONTENTS	3
4	TEST SUMMARY	4
4.1	MEASUREMENT UNCERTAINTY	4
5	GENERAL INFORMATION	5
5.1	GENERAL DESCRIPTION OF EUT	5
5.2	TEST MODE	8
5.3	TEST FACILITY.....	8
5.4	TEST LOCATION	8
5.5	DESCRIPTION OF SUPPORT UNITS	8
5.6	DEVIATION FROM STANDARDS.....	8
5.7	ABNORMALITIES FROM STANDARD CONDITIONS.....	8
5.8	ADDITIONAL INSTRUCTIONS.....	8
6	TEST INSTRUMENTS LIST	9
7	TEST RESULTS AND MEASUREMENT DATA.....	11
7.1	ANTENNA REQUIREMENT	11
7.2	CONDUCTED EMISSIONS	12
7.3	CONDUCTED PEAK OUTPUT POWER	15
7.4	20dB EMISSION BANDWIDTH	16
7.5	CARRIER FREQUENCIES SEPARATION.....	17
7.6	HOPPING CHANNEL NUMBER	18
7.7	DWELL TIME.....	19
7.8	SPURIOUS EMISSION IN NON-RESTRICTED & RESTRICTED BANDS	20
7.8.1	Conducted Emission Method.....	20
7.8.2	Radiated Emission Method.....	21
8	TEST SETUP PHOTO	43
9	EUT CONSTRUCTIONAL DETAILS	43

4 Test Summary

Test Item	Section	Result
Antenna Requirement	15.203/15.247 (c)	Pass
AC Power Line Conducted Emission	15.207	Pass
Conducted Peak Output Power	15.247 (b)(1)	Pass
20dB Occupied Bandwidth	15.247 (a)(1)	Pass
Carrier Frequencies Separation	15.247 (a)(1)	Pass
Hopping Channel Number	15.247 (a)(1)(iii)	Pass
Dwell Time	15.247 (a)(1)(iii)	Pass
Radiated Emission	15.205/15.209	Pass
Band Edge	15.247(d)	Pass

Pass: The EUT complies with the essential requirements in the standard.

Remark: Test according to ANSI C63.10:2013 .

4.1 Measurement Uncertainty

No.	Item	Measurement Uncertainty
1	Radio Frequency	$\pm 7.25 \times 10^{-8}$
2	Duty cycle	$\pm 0.37\%$
3	Occupied Bandwidth	$\pm 3\%$
4	RF conducted power	$\pm 0.75\text{dB}$
5	RF power density	$\pm 3\text{dB}$
6	Conducted Spurious emissions	$\pm 2.58\text{dB}$
7	AC Power Line Conducted Emission	$\pm 3.44\text{dB}$ (0.15MHz ~ 30MHz)
8	Radiated Spurious emission test	$\pm 3.1\text{dB}$ (9kHz-30MHz)
		$\pm 3.8039\text{dB}$ (30MHz-200MHz)
		$\pm 3.9679\text{dB}$ (200MHz-1GHz)
		$\pm 4.29\text{dB}$ (1GHz-18GHz)
		$\pm 3.30\text{dB}$ (18GHz-40GHz)
9	Temperature test	$\pm 1^\circ\text{C}$
10	Humidity test	$\pm 3\%$
11	Time	$\pm 3\%$

5 General Information

5.1 General Description of EUT

Product Name:	12-Channel Receiver
Model No.:	Xr12
Serial No.:	RD1001641
Test sample(s) ID:	GTS2024100126-1
Sample(s) Status	Engineer sample
Operation Frequency:	2402.15MHz~2479.85MHz
Channel numbers:	171
Modulation method:	FHSS
Modulation technology:	GMSK
Antenna Type:	ANT 1: Integral antenna ANT 2: Integral antenna
Antenna gain:	ANT 1: 2.89dBi ANT 2: 2.89dBi
Power supply:	DC 3.5-9V

Remark:

1. Antenna gain information provided by the customer
2. The relevant information of the sample is provided by the entrusting company, and the laboratory is not responsible for its authenticity.
3. The system works in the frequency range of 2402.15MHz to 2479.85MHz. This band has been divided to 171 independent channels. Each radio system uses 32 different channels; the minimum channel separation is ≥ 1.8 MHz. By using various switch-on times, hopping scheme and channel frequencies, the system can guarantee a jamming free radio transmission. Pre-testing all radio systems, this radio system recorded in the report is the worst mode. The channel list is below.

Operation Frequency each of channel							
Channel	Frequency (MHz)	Channel	Frequency (MHz)	Channel	Frequency (MHz)	Channel	Frequency (MHz)
1	2402.15	44	2421.5	87	2440.85	130	2461.4
2	2402.6	45	2421.95	88	2441.3	131	2461.85
3	2403.05	46	2422.4	89	2441.75	132	2462.3
4	2403.5	47	2422.85	90	2442.2	133	2462.75
5	2403.95	48	2423.3	91	2442.65	134	2463.2
6	2404.4	49	2423.75	92	2443.1	135	2463.65
7	2404.85	50	2424.2	93	2444.75	136	2464.1
8	2405.3	51	2424.65	94	2445.2	137	2464.55
9	2405.75	52	2425.1	95	2445.65	138	2465
10	2406.2	53	2425.55	96	2446.1	139	2465.45
11	2406.65	54	2426	97	2446.55	140	2465.9
12	2407.1	55	2426.45	98	2447	141	2466.35
13	2407.55	56	2426.9	99	2447.45	142	2466.8
14	2408	57	2427.35	100	2447.9	143	2467.25
15	2408.45	58	2427.8	101	2448.35	144	2467.7
16	2408.9	59	2428.25	102	2448.8	145	2468.15
17	2409.35	60	2428.7	103	2449.25	146	2468.6
18	2409.8	61	2429.15	104	2449.7	147	2469.05
19	2410.25	62	2429.6	105	2450.15	148	2469.5
20	2410.7	63	2430.05	106	2450.6	149	2469.95
21	2411.15	64	2430.5	107	2451.05	150	2470.4
22	2411.6	65	2430.95	108	2451.5	151	2470.85
23	2412.05	66	2431.4	109	2451.95	152	2471.3
24	2412.5	67	2431.85	110	2452.4	153	2471.75
25	2412.95	68	2432.3	111	2452.85	154	2472.2
26	2413.4	69	2432.75	112	2453.3	155	2472.65
27	2413.85	70	2433.2	113	2453.75	156	2473.1
28	2414.3	71	2433.65	114	2454.2	157	2473.55
29	2414.75	72	2434.1	115	2454.65	158	2474
30	2415.2	73	2434.55	116	2455.1	159	2474.45
31	2415.65	74	2435	117	2455.55	160	2474.9
32	2416.1	75	2435.45	118	2456	161	2475.35
33	2416.55	76	2435.9	119	2456.45	162	2475.8
34	2417	77	2436.35	120	2456.9	163	2476.25
35	2417.45	78	2436.8	121	2457.35	164	2476.7
36	2417.9	79	2437.25	122	2457.8	165	2477.15
37	2418.35	80	2437.7	123	2458.25	166	2477.6
38	2418.8	81	2438.15	124	2458.7	167	2478.05

39	2419.25	82	2438.6	125	2459.15	168	2478.5
40	2419.7	83	2439.05	126	2459.6	169	2478.95
41	2420.15	84	2439.5	127	2460.05	170	2479.4
42	2420.6	85	2439.95	128	2460.5	171	2479.85
43	2421.05	86	2440.4	129	2460.95		

The test frequencies are below:

Channel	Frequency
The lowest channel	2402.15MHz
The middle channel	2440.4MHz
The Highest channel	2479.85MHz

5.2 Test mode

Transmitting mode	Keep the EUT in transmitting mode.
-------------------	------------------------------------

5.3 Test Facility

<p>The test facility is recognized, certified, or accredited by the following organizations:</p> <ul style="list-style-type: none"> ● FCC —Registration No.: 381383 Designation Number: CN5029 Global United Technology Services Co., Ltd., Shenzhen EMC Laboratory has been registered and fully described in a report filed with the (FCC) Federal Communications Commission. The acceptance letter from the FCC is maintained in files. ● ISED—Registration No.: 9079A CAB identifier: CN0091 The 3m Semi-anechoic chamber of Global United Technology Services Co., Ltd. has been registered by Certification and Engineering Bureau of ISED for radio equipment testing. ● NVLAP (LAB CODE:600179-0) Global United Technology Services Co., Ltd., is accredited by the National Voluntary Laboratory Accreditation Program (NVLAP).
--

5.4 Test Location

All other tests were performed at:
<p>Global United Technology Services Co., Ltd. Address: No. 123-128, Tower A, Jinyuan Business Building, No.2, Laodong Industrial Zone, Xixiang Road, Baoan District, Shenzhen, Guangdong, China 518102 Tel: 0755-27798480 Fax: 0755-27798960</p>

5.5 Description of Support Units

Manufacturer	Description	Model	Serial Number
ShenZhen FLYSKY Technology Co.,Ltd	Remote control	FT18	N/A
GW	DC POWER SUPPLY	GPR-6030D	EF924756

5.6 Deviation from Standards

None.

5.7 Abnormalities from Standard Conditions

None.

5.8 Additional Instructions

Software (Used for test) from client
Built-in by manufacturer, power set default.

6 Test Instruments list

Radiated Emission:						
Item	Test Equipment	Manufacturer	Model No.	Inventory No.	Cal.Date (mm-dd-yy)	Cal.Due date (mm-dd-yy)
1	3m Semi- Anechoic Chamber	ZhongYu Electron	9.2(L)*6.2(W)* 6.4(H)	GTS250	Jun. 22, 2024	Jun. 21, 2027
2	Control Room	ZhongYu Electron	6.2(L)*2.5(W)* 2.4(H)	GTS251	N/A	N/A
3	EMI Test Receiver	Rohde & Schwarz	ESU26	GTS203	Apr. 11, 2024	Apr. 10, 2025
4	BiConiLog Antenna	SCHWARZBECK MESS-ELEKTRONIK	VULB9168	GTS640	Mar. 19, 2023	Mar. 18, 2025
5	Double -ridged waveguide horn	SCHWARZBECK MESS-ELEKTRONIK	BBHA 9120 D	GTS208	Apr. 17, 2023	Apr. 16, 2025
6	EMI Test Software	AUDIX	E3	N/A	N/A	N/A
7	Wideband Radio Communication Tester	Rohde & Schwarz	CMW500	GTS575	Apr. 11, 2024	Apr. 10, 2025
8	Loop Antenna	ZHINAN	ZN30900A	GTS534	Nov. 13, 2023	Nov.12, 2024
9	Broadband Preamplifier	SCHWARZBECK	BBV9718	GTS535	Apr. 11, 2024	Apr. 10, 2025
10	Amplifier(1GHz-26.5GHz)	HP	8449B	GTS601	Apr. 11, 2024	Apr. 10, 2025
11	Horn Antenna (15GH-40GHz)	SCHWARZBECK	01296	GTS691	Mar. 07, 2024	Mar. 06, 2025
12	FSV·Signal Analyzer (10Hz-40GHz)	Keysight	FSV-40-N	GTS666	Mar. 12, 2024	Mar. 11, 2025
13	Amplifier	/	LNA-1000-30S	GTS650	Apr. 11, 2024	Apr. 10, 2025
14	CDNE M2+M3-16A	HCT	30MHz-300MHz	GTS692	Nov. 08, 2023	Nov. 07, 2024
15	Wideband Amplifier	/	WDA-01004000-15P35	GTS602	Apr. 11, 2024	Apr. 10, 2025
16	Thermo meter	JINCHUANG	GSP-8A	GTS643	Apr. 18, 2024	Apr. 17, 2025
17	RE cable 1	GTS	N/A	GTS675	Jul. 02, 2024	Jul. 01, 2025
18	RE cable 2	GTS	N/A	GTS676	Jul. 02, 2024	Jul. 01, 2025
19	RE cable 3	GTS	N/A	GTS677	Jul. 02, 2024	Jul. 01, 2025
20	RE cable 4	GTS	N/A	GTS678	Jul. 02, 2024	Jul. 01, 2025
21	RE cable 5	GTS	N/A	GTS679	Jul. 02, 2024	Jul. 01, 2025
22	RE cable 6	GTS	N/A	GTS680	Jul. 02, 2024	Jul. 01, 2025
23	RE cable 7	GTS	N/A	GTS681	Jul. 05, 2024	Jul. 04, 2025
24	RE cable 8	GTS	N/A	GTS682	Jul. 05, 2024	Jul. 04, 2025

Conducted Emission						
Item	Test Equipment	Manufacturer	Model No.	Inventory No.	Cal.Date (mm-dd-yy)	Cal.Due date (mm-dd-yy)
1	Shielding Room	ZhongYu Electron	7.3(L)x3.1(W)x2.9(H)	GTS252	Jul. 12, 2022	Jul. 11, 2027
2	EMI Test Receiver	R&S	ESCI 7	GTS552	Apr. 11, 2024	Apr. 10, 2025
3	LISN	ROHDE & SCHWARZ	ENV216	GTS226	Apr. 11, 2024	Apr. 10, 2025
4	Coaxial Cable	GTS	N/A	GTS227	N/A	N/A
5	EMI Test Software	AUDIX	E3	N/A	N/A	N/A
6	Thermo meter	JINCHUANG	GSP-8A	GTS642	Apr. 18, 2024	Apr. 17, 2025
7	Absorbing clamp	Elektronik-Feinmechanik	MDS21	GTS229	Apr. 11, 2024	Apr. 10, 2025
8	ISN	SCHWARZBECK	NTFM 8158	GTS565	Apr. 11, 2024	Apr. 10, 2025
9	High voltage probe	SCHWARZBECK	TK9420	GTS537	Apr. 11, 2024	Apr. 10, 2025
10	Antenna end assembly	Weinschel	1870A	GTS560	Apr. 11, 2024	Apr. 10, 2025

RF Conducted Test:						
Item	Test Equipment	Manufacturer	Model No.	Serial No.	Cal.Date (mm-dd-yy)	Cal.Due date (mm-dd-yy)
1	MXA Signal Analyzer	Agilent	N9020A	GTS566	Apr. 13, 2024	Apr. 12, 2025
2	EMI Test Receiver	R&S	ESCI 7	GTS552	Apr. 13, 2024	Apr. 12, 2025
3	PSA Series Spectrum Analyzer	Agilent	E4440A	GTS536	Apr. 13, 2024	Apr. 12, 2025
4	MXG vector Signal Generator	Agilent	N5182A	GTS567	Apr. 13, 2024	Apr. 12, 2025
5	ESG Analog Signal Generator	Agilent	E4428C	GTS568	Apr. 13, 2024	Apr. 12, 2025
6	USB RF Power Sensor	DARE	RPR3006W	GTS569	Apr. 13, 2024	Apr. 12, 2025
7	RF Switch Box	Shongyi	RFSW3003328	GTS571	Apr. 13, 2024	Apr. 12, 2025
8	Programmable Constant Temp & Humi Test Chamber	WEWON	WHTH-150L-40-880	GTS572	Apr. 13, 2024	Apr. 12, 2025
9	Thermo meter	JINCHUANG	GSP-8A	GTS641	Apr. 18, 2024	Apr. 17, 2025
10	EXA Signal Analyzer	Keysight	N9010B	MY60241168	Nov. 02, 2024	Nov. 01, 2025

General used equipment:						
Item	Test Equipment	Manufacturer	Model No.	Inventory No.	Cal.Date (mm-dd-yy)	Cal.Due date (mm-dd-yy)
1	Barometer	KUMAO	SF132	GTS647	Apr. 18, 2024	Apr. 17, 2025

7 Test results and Measurement Data

7.1 Antenna requirement

Standard requirement:	FCC Part15 C Section 15.203 /247(c)
15.203 requirement: An intentional radiator shall be designed to ensure that no antenna other than that furnished by the responsible party shall be used with the device. The use of a permanently attached antenna or of an antenna that uses a unique coupling to the intentional radiator, the manufacturer may design the unit so that a broken antenna can be replaced by the user, but the use of a standard antenna jack or electrical connector is prohibited.	
15.247(c) (1)(i) requirement: (i) Systems operating in the 2400-2483.5 MHz band that is used exclusively for fixed. Point-to-point operations may employ transmitting antennas with directional gain greater than 6dBi provided the maximum conducted output power of the intentional radiator is reduced by 1 dB for every 3 dB that the directional gain of the antenna exceeds 6dBi.	
EUT Antenna:	
The antenna is integral antenna, reference to the appendix II for details.	

7.2 Conducted Emissions

Test Requirement:	FCC Part15 C Section 15.207					
Test Method:	ANSI C63.10:2013					
Test Frequency Range:	150KHz to 30MHz					
Receiver setup:	RBW=9KHz, VBW=30KHz, Sweep time=auto					
Limit:	Frequency range (MHz)		Limit (dBuV)			
			Quasi-peak		Average	
	0.15-0.5		66 to 56*		56 to 46*	
	0.5-5		56		46	
	5-30		60		50	
* Decreases with the logarithm of the frequency.						
Test setup:	<p>Remark: E.U.T: Equipment Under Test LISN: Line Impedance Stabilization Network Test table height=0.8m</p>					
Test procedure:	<ol style="list-style-type: none"> 1. The E.U.T and simulators are connected to the main power through a line impedance stabilization network (L.I.S.N.). This provides a 50ohm/50uH coupling impedance for the measuring equipment. 2. The peripheral devices are also connected to the main power through a LISN that provides a 50ohm/50uH coupling impedance with 50ohm termination. (Please refer to the block diagram of the test setup and photographs). 3. Both sides of A.C. line are checked for maximum conducted interference. In order to find the maximum emission, the relative positions of equipment and all of the interface cables must be changed according to ANSI C63.10:2013 on conducted measurement. 					
Test Instruments:	Refer to section 6.0 for details					
Test mode:	Refer to section 5.2 for details					
Test environment:	Temp.:	25 °C	Humid.:	52%	Press.:	1012mbar
Test voltage:	AC 120V, 60Hz					
Test results:	Pass					

Measurement data:

Pre-scan all test modes, found worst case at 2402.15MHz@Ant 1, and so only show the test result of it.

Line:

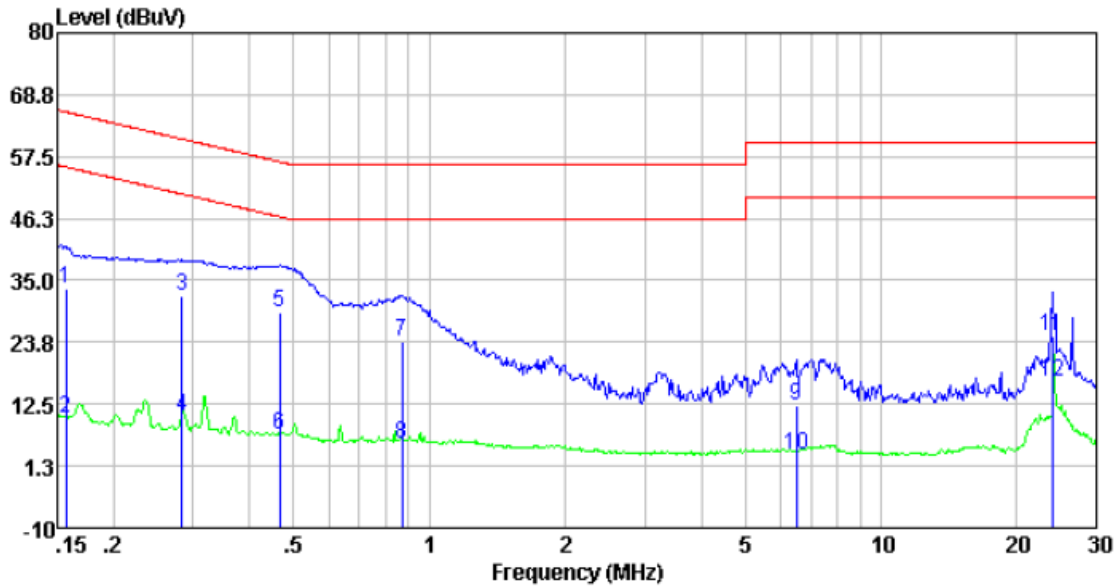

Freq	Reading level	LISN/ISN factor	Cable loss	Level	Limit level	Over limit	Remark
MHz	dBuV	dB	dB	dBuV	dBuV	dB	
0.16	23.61	9.99	0.01	33.61	65.65	-32.04	QP
0.16	-0.02	9.99	0.01	9.98	55.65	-45.67	Average
0.28	22.68	9.64	0.01	32.33	60.72	-28.39	QP
0.28	0.55	9.64	0.01	10.20	50.72	-40.52	Average
0.47	19.32	9.79	0.01	29.12	56.58	-27.46	QP
0.47	-2.94	9.79	0.01	6.86	46.58	-39.72	Average
0.87	14.25	9.72	0.03	24.00	56.00	-32.00	QP
0.87	-4.45	9.72	0.03	5.30	46.00	-40.70	Average
6.49	2.42	9.72	0.08	12.22	60.00	-47.78	QP
6.49	-6.39	9.72	0.08	3.41	50.00	-46.59	Average
23.89	14.87	9.95	0.19	25.01	60.00	-34.99	QP
23.89	6.37	9.95	0.19	16.51	50.00	-33.49	Average

Neutral:

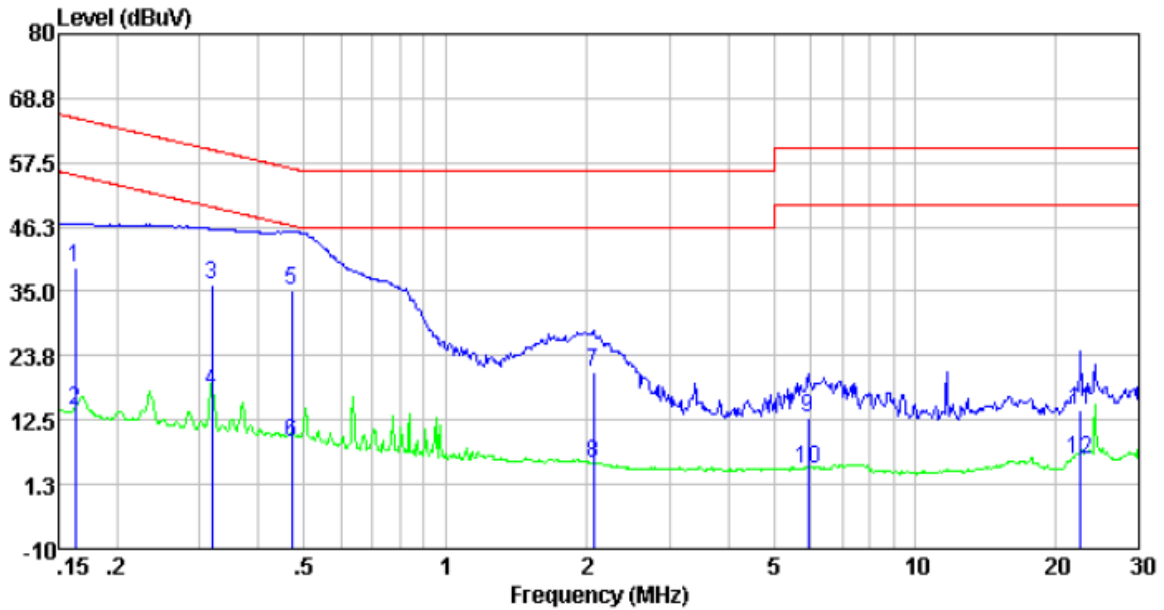

Freq	Reading level	LISN/ISN factor	Cable loss	Level	Limit level	Over limit	Remark
MHz	dBuV	dB	dB	dBuV	dBuV	dB	
0.16	29.14	9.93	0.01	39.08	65.34	-26.26	QP
0.16	4.14	9.93	0.01	14.08	55.34	-41.26	Average
0.32	26.35	9.79	0.01	36.15	59.75	-23.60	QP
0.32	7.86	9.79	0.01	17.66	49.75	-32.09	Average
0.47	25.50	9.73	0.01	35.24	56.49	-21.25	QP
0.47	-0.99	9.73	0.01	8.75	46.49	-37.74	Average
2.07	11.14	9.79	0.04	20.97	56.00	-35.03	QP
2.07	-4.79	9.79	0.04	5.04	46.00	-40.96	Average
5.93	3.24	9.71	0.07	13.02	60.00	-46.98	QP
5.93	-5.83	9.71	0.07	3.95	50.00	-46.05	Average
22.54	4.11	9.87	0.19	14.17	60.00	-45.83	QP
22.54	-4.37	9.87	0.19	5.69	50.00	-44.31	Average

Notes:

1. An initial pre-scan was performed on the line and neutral lines with peak detector.
2. Quasi-Peak and Average measurement were performed at the frequencies with maximized peak emission.
3. Final Level = Receiver Read level + LISN Factor + Cable Loss

7.3 Conducted Peak Output Power

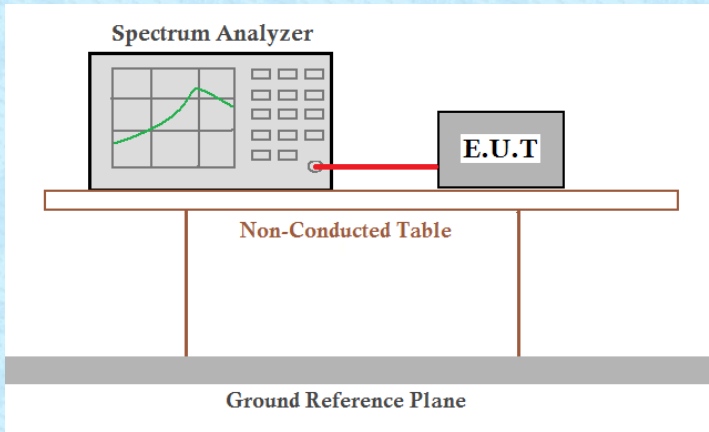
Test Requirement:	FCC Part15 C Section 15.247(a)(1)
Test Method:	ANSI C63.10:2013
Limit:	20.97dBm
Test setup:	 <p>The diagram illustrates the test setup. A Spectrum Analyzer is connected to an E.U.T. (Equipment Under Test) via a red cable. Both are placed on a Non-Conducted Table, which sits on a Ground Reference Plane.</p>
Test Instruments:	Refer to section 6.0 for details
Test mode:	Refer to section 5.2 for details
Test results:	Pass

Measurement Data: The detailed test data see Appendix for 2.4G.

7.4 20dB Emission Bandwidth

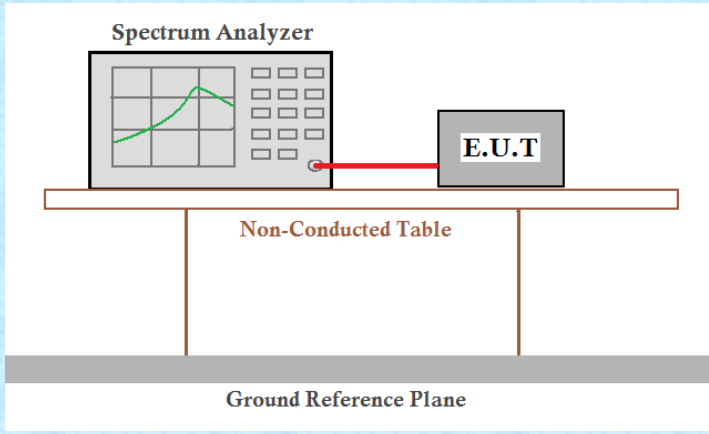
Test Requirement:	FCC Part15 C Section 15.247 (a)(1)
Test Method:	ANSI C63.10:2013
Limit:	N/A
Test setup:	 <p>The diagram illustrates the test setup. A Spectrum Analyzer is connected to an E.U.T. (Equipment Under Test) via a red cable. Both are placed on a Non-Conducted Table, which is supported by a Ground Reference Plane.</p>
Test Instruments:	Refer to section 6.0 for details
Test mode:	Refer to section 5.2 for details
Test results:	Pass

Measurement Data: The detailed test data see Appendix for 2.4G.

7.5 Carrier Frequencies Separation

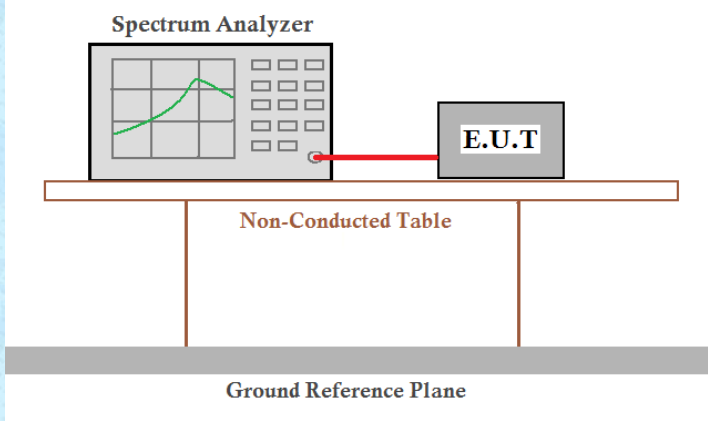
Test Requirement:	FCC Part15 C Section 15.247 (a)(1)
Test Method:	ANSI C63.10:2013
Receiver setup:	RBW=100KHz, VBW=300KHz, detector=Peak
Limit:	0.025MHz or 2/3 of the 20dB bandwidth (whichever is greater)
Test setup:	 <p>The diagram illustrates the test setup. A Spectrum Analyzer is connected to an E.U.T. (Equipment Under Test) via a red cable. Both are placed on a Non-Conducted Table, which is supported by a Ground Reference Plane.</p>
Test Instruments:	Refer to section 6.0 for details
Test mode:	Refer to section 5.2 for details
Test results:	Pass

Measurement Data: The detailed test data see Appendix for 2.4G.

7.6 Hopping Channel Number

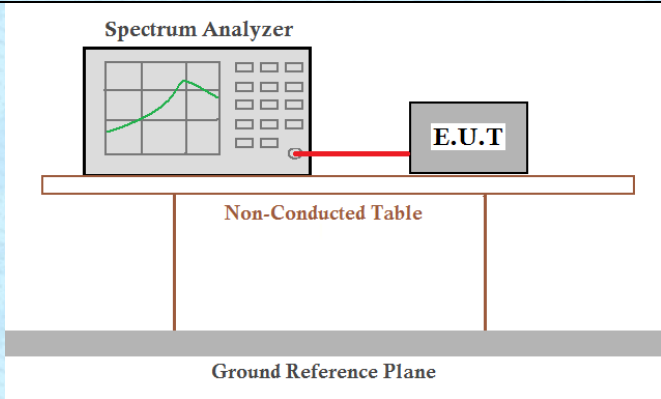
Test Requirement:	FCC Part15 C Section 15.247 (a)(1)(iii)
Test Method:	ANSI C63.10:2013
Receiver setup:	RBW=100KHz, VBW=300KHz, Frequency range=2400MHz-2483.5MHz, Detector=Peak
Limit:	15 channels
Test setup:	 <p>The diagram illustrates the test setup. A Spectrum Analyzer is connected to an E.U.T. (Equipment Under Test) via a red cable. Both are placed on a Non-Conducted Table, which sits on a Ground Reference Plane.</p>
Test Instruments:	Refer to section 6.0 for details
Test mode:	Refer to section 5.2 for details
Test results:	Pass

Measurement Data: The detailed test data see Appendix for 2.4G.

7.7 Dwell Time

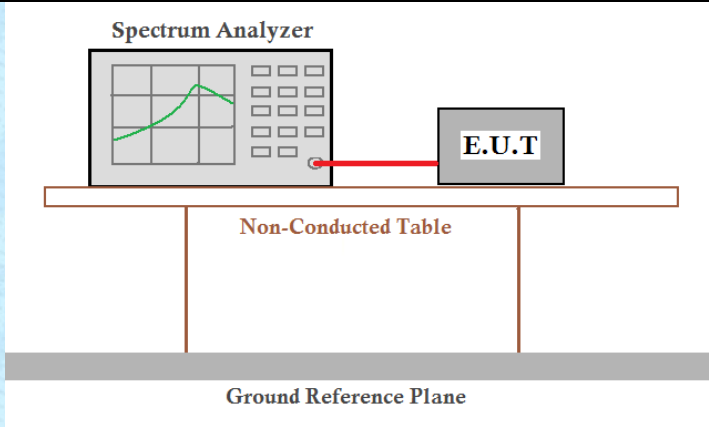
Test Requirement:	FCC Part15 C Section 15.247 (a)(1)(iii)
Test Method:	ANSI C63.10:2013
Receiver setup:	RBW=300KHz, VBW=300KHz, Span=0Hz, Detector=Peak
Limit:	0.4 Second
Test setup:	 <p>The diagram illustrates the test setup. A Spectrum Analyzer is connected to an E.U.T. (Equipment Under Test) via a red cable. Both are placed on a Non-Conducted Table, which is supported by a Ground Reference Plane.</p>
Test Instruments:	Refer to section 6.0 for details
Test mode:	Refer to section 5.2 for details
Test results:	Pass

Measurement Data: The detailed test data see Appendix for 2.4G.

7.8 Spurious Emission in Non-restricted & restricted Bands

7.8.1 Conducted Emission Method

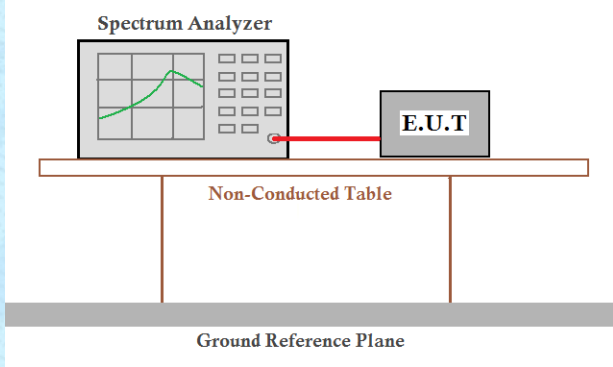
Test Requirement:	FCC Part15 C Section 15.247 (d)
Test Method:	ANSI C63.10:2013
Receiver setup:	RBW=100kHz, VBW=300kHz, Detector=Peak
Limit:	In any 100 kHz bandwidth outside the frequency band in which the spread spectrum intentional radiator is operating, the radio frequency power that is produced by the intentional radiator shall be at least 20 dB below that in the 100 kHz bandwidth within the band that contains the highest level of the desired power, based on either an RF conducted or a radiated measurement.
Test setup:	 <p>The diagram illustrates the test setup. A Spectrum Analyzer is connected to an E.U.T. (Equipment Under Test) via a red cable. Both the Spectrum Analyzer and the E.U.T. are placed on a Non-Conducted Table. The table is supported by a Ground Reference Plane.</p>
Test Instruments:	Refer to section6.0 for details
Test mode:	Refer to section 5.2 for details
Test results:	Pass

Measurement Data: The detailed test data see Appendix for 2.4G.

7.8.2 Radiated Emission Method

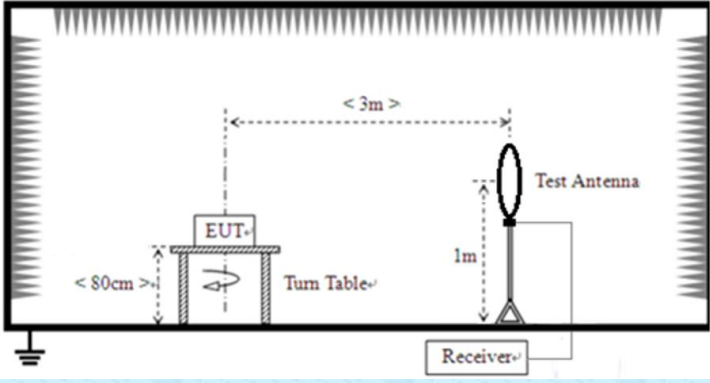
Test Requirement:	FCC Part15 C Section 15.209 and 15.205				
Test Method:	ANSI C63.10:2013				
Test Frequency Range:	9kHz to 25GHz				
Test site:	Measurement Distance: 3m				
Receiver setup:	Frequency	Detector	RBW	VBW	Value
	9KHz-150KHz	Quasi-peak	200Hz	600Hz	Quasi-peak
	150KHz-30MHz	Quasi-peak	9KHz	30KHz	Quasi-peak
	30MHz-1GHz	Quasi-peak	120KHz	300KHz	Quasi-peak
	Above 1GHz	Peak	1MHz	3MHz	Peak
		Peak	1MHz	10Hz	Average
Note: For Duty cycle $\geq 98\%$, average detector set as above For Duty cycle $< 98\%$, average detector set as below: $VBW \geq 1 / T$					
Limit: (Spurious Emissions)	Frequency	Limit (uV/m)	Value	Measurement Distance	
	0.009MHz-0.490MHz	2400/F(KHz)	QP	300m	
	0.490MHz-1.705MHz	24000/F(KHz)	QP	30m	
	1.705MHz-30MHz	30	QP	30m	
	30MHz-88MHz	100	QP	3m	
	88MHz-216MHz	150	QP		
	216MHz-960MHz	200	QP		
	960MHz-1GHz	500	QP		
	Above 1GHz	500	Average		
		5000	Peak		
Test setup:	Below 30MHz				
					
Below 1GHz					

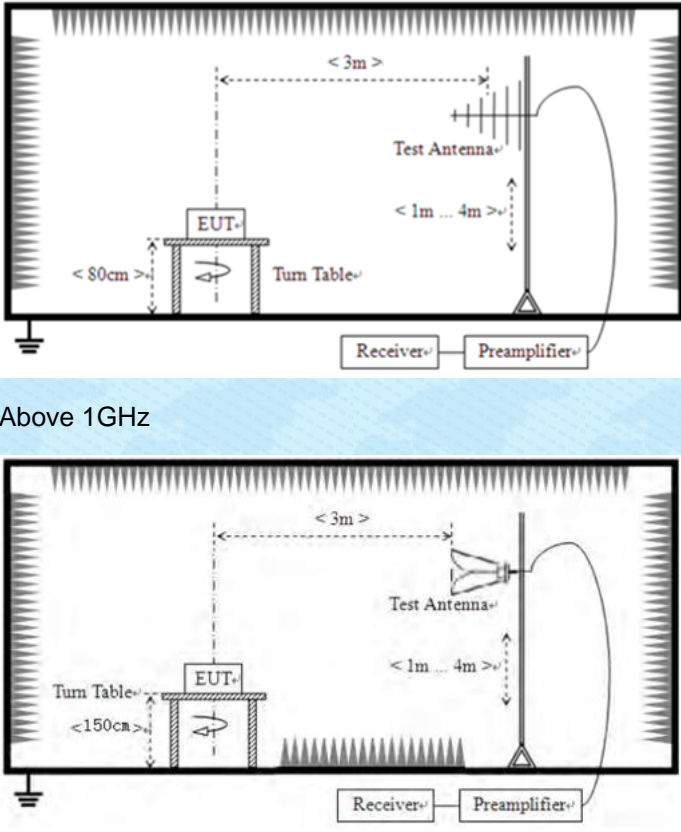
	 <p>Above 1GHz</p>						
<p>Test Procedure:</p>	<ol style="list-style-type: none"> 1. The EUT was placed on the top of a rotating table (0.8 meters for below 1GHz and 1.5meters for above 1GHz) above the ground at a 3 meter camber. The table was rotated 360 degrees to determine the position of the highest radiation. 2. The EUT was set 3 meters away from the interference-receiving antenna, which was mounted on the top of a variable-height antenna tower. 3. The antenna height is varied from one meter to four meters above the ground to determine the maximum value of the field strength. Both horizontal and vertical polarizations of the antenna are set to make the measurement. 4. For each suspected emission, the EUT was arranged to its worst case and then the antenna was tuned to heights from 1 meter to 4 meters and the rota table was turned from 0 degrees to 360 degrees to find the maximum reading. 5. The test-receiver system was set to Peak Detect Function and Specified Bandwidth with Maximum Hold Mode. 6. If the emission level of the EUT in peak mode was 10dB lower than the limit specified, then testing could be stopped and the peak values of the EUT would be reported. Otherwise the emissions that did not have 10dB margin would be re-tested one by one using peak, quasi-peak or average method as specified and then reported in a data sheet. 						
<p>Test Instruments:</p>	<p>Refer to section 5.8 for details</p>						
<p>Test mode:</p>	<p>Refer to section 5.2 for details</p>						
<p>Temp. / Hum.</p>	<table border="1"> <tr> <td>Temp.:</td> <td>25 °C</td> <td>Humid.:</td> <td>52%</td> <td>Press.:</td> <td>1 012mbar</td> </tr> </table>	Temp.:	25 °C	Humid.:	52%	Press.:	1 012mbar
Temp.:	25 °C	Humid.:	52%	Press.:	1 012mbar		

Test results:	Pass
---------------	------

Remark:

1. Pre-scan all kind of the place mode (X-axis, Y-axis, Z-axis), and found the Y-axis which it is worse case.

Measurement data:

■ **Below 30MHz**

The low frequency, which started from 9 kHz to 30 MHz, was pre-scanned and the result which was 20 dB lower than the limit line per 15.31(o) was not reported.

30MHz ~ 1GHz

All antennas have test, only the worst case ANT 1 report.

Test channel:	Lowest	Polarization:	Horizontal
---------------	--------	---------------	------------

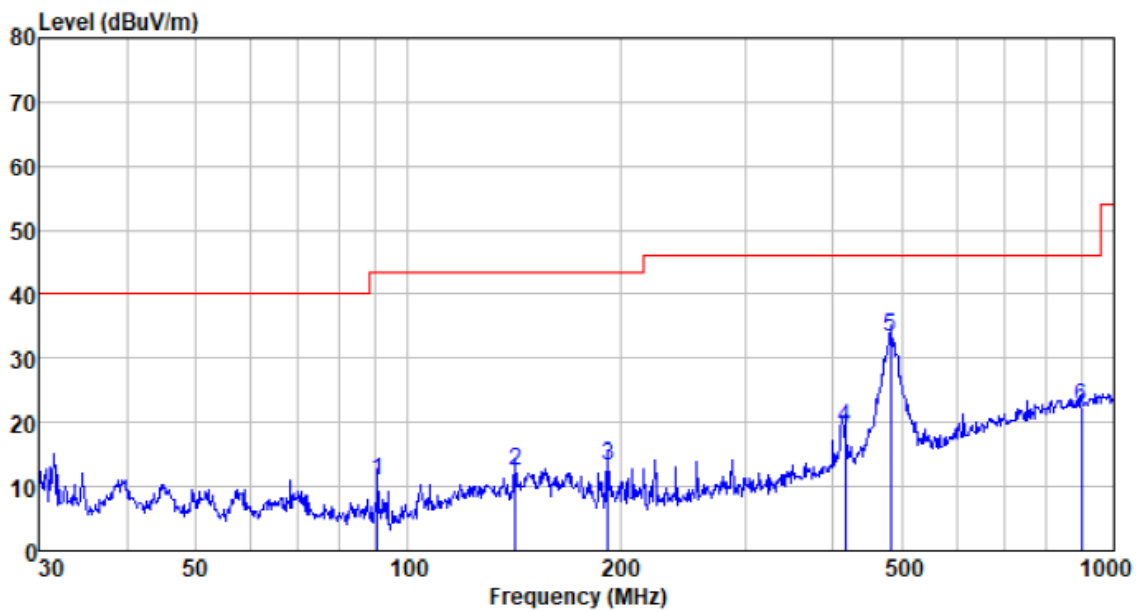

Freq MHz	Reading level dBuV	Antenna factor dB/m	Cable loss dB	Preamp factor dB	level dBuV/m	Limit level dBuV/m	Over limit dB	Remark
90.537	32.86	8.65	1.78	32.46	10.83	43.50	-32.67	QP
141.826	28.58	13.88	2.39	32.46	12.39	43.50	-31.11	QP
191.745	32.31	10.63	2.79	32.41	13.32	43.50	-30.18	QP
416.179	32.33	15.15	3.94	32.24	19.18	46.00	-26.82	QP
482.216	44.80	16.50	4.14	32.21	33.23	46.00	-12.77	QP
900.147	24.85	23.10	5.73	31.10	22.58	46.00	-23.42	QP

Test channel:	Lowest	Polarization:	Vertical
---------------	--------	---------------	----------

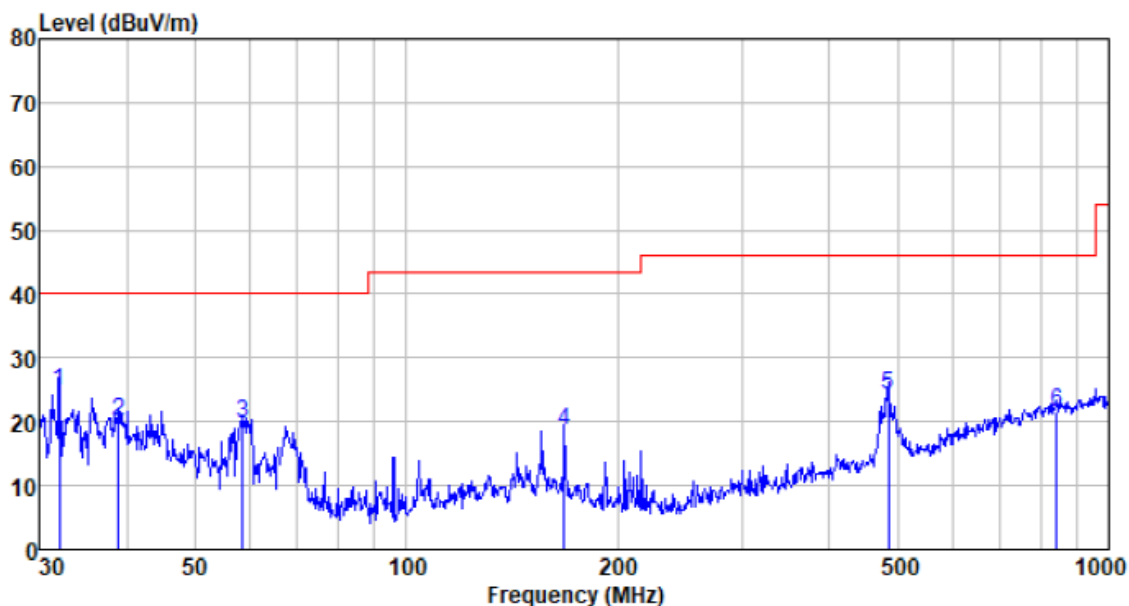

Freq MHz	Reading level dBuV	Antenna factor dB/m	Cable loss dB	Preamp factor dB	level dBuV/m	Limit level dBuV/m	Over limit dB	Remark
32.067	43.59	12.51	1.14	32.30	24.94	40.00	-15.06	QP
38.888	36.93	14.17	1.24	32.30	20.04	40.00	-19.96	QP
58.407	38.58	12.18	1.47	32.33	19.90	40.00	-20.10	QP
167.824	34.72	13.62	2.62	32.43	18.53	43.50	-24.97	QP
485.609	35.74	16.51	4.15	32.21	24.19	46.00	-21.81	QP
842.130	24.44	22.50	5.58	31.10	21.42	46.00	-24.58	QP

Test channel:	Middle	Polarization:	Horizontal
---------------	--------	---------------	------------

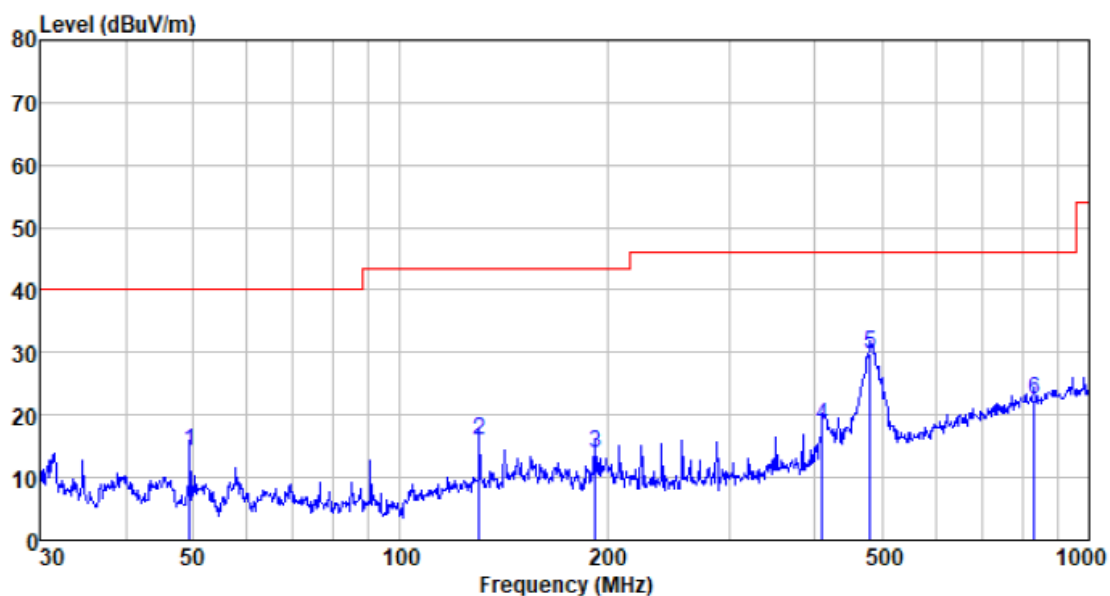

Freq MHz	Reading level dBuV	Antenna factor dB/m	Cable loss dB	Preamp factor dB	level dBuV/m	Limit level dBuV/m	Over limit dB	Remark
49.533	32.29	12.69	1.38	32.30	14.06	40.00	-25.94	QP
130.379	32.79	13.24	2.28	32.47	15.84	43.50	-27.66	QP
191.745	32.80	10.63	2.79	32.41	13.81	43.50	-29.69	QP
410.383	31.67	15.01	3.92	32.24	18.36	46.00	-27.64	QP
480.528	41.33	16.50	4.13	32.21	29.75	46.00	-16.25	QP
833.317	25.66	22.40	5.56	31.10	22.52	46.00	-23.48	QP

Test channel:	Middle	Polarization:	Vertical
---------------	--------	---------------	----------

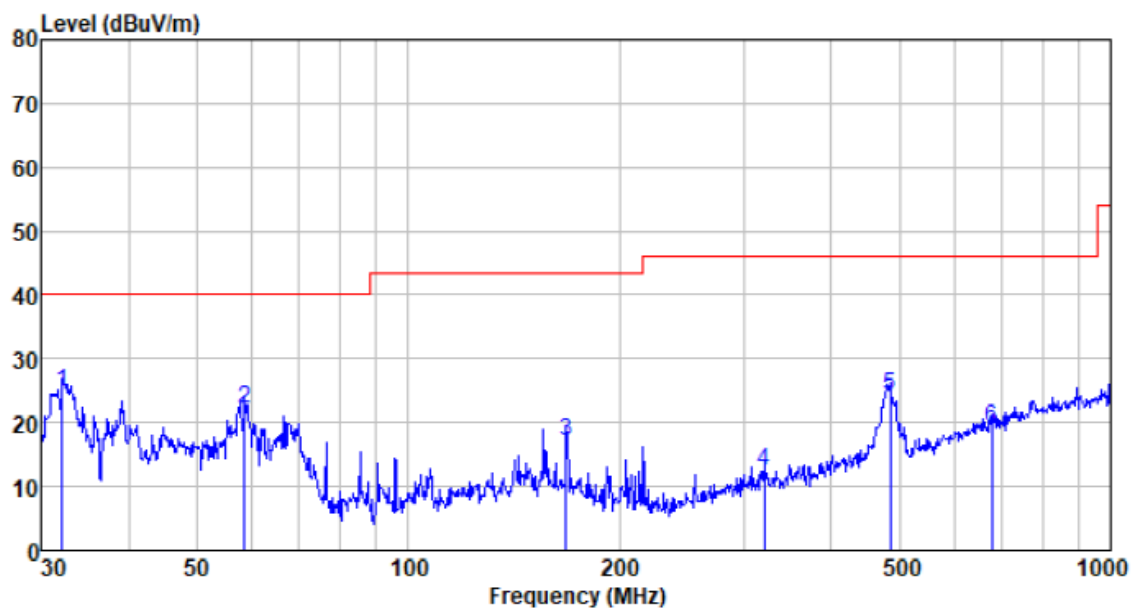

Freq MHz	Reading level dBuV	Antenna factor dB/m	Cable loss dB	Preamp factor dB	level dBuV/m	Limit level dBuV/m	Over limit dB	Remark
32.179	43.54	12.52	1.14	32.30	24.90	40.00	-15.10	QP
58.407	40.94	12.18	1.47	32.33	22.26	40.00	-17.74	QP
167.824	33.33	13.62	2.62	32.43	17.14	43.50	-26.36	QP
321.061	28.15	12.92	3.53	32.29	12.31	46.00	-33.69	QP
485.609	35.73	16.51	4.15	32.21	24.18	46.00	-21.82	QP
677.580	25.45	20.25	4.98	31.55	19.13	46.00	-26.87	QP

Test channel:	Highest	Polarization:	Horizontal
---------------	---------	---------------	------------

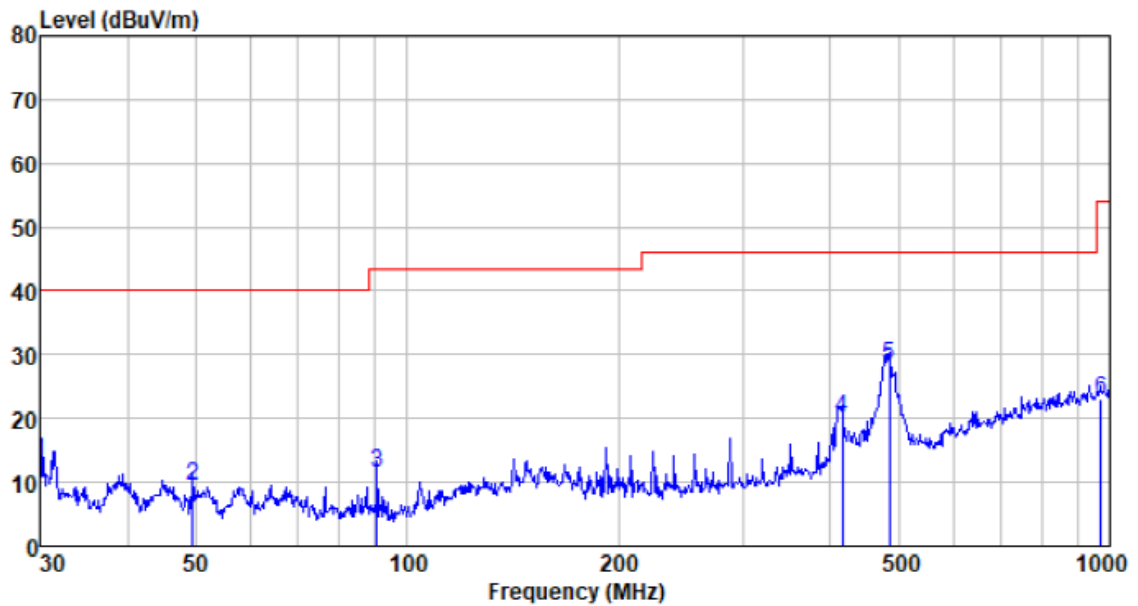

Freq MHz	Reading level dBuV	Antenna factor dB/m	Cable loss dB	Preamp factor dB	level dBuV/m	Limit level dBuV/m	Over limit dB	Remark
30.000	32.04	12.40	1.10	32.30	13.24	40.00	-26.76	QP
49.533	27.71	12.69	1.38	32.30	9.48	40.00	-30.52	QP
90.537	33.40	8.65	1.78	32.46	11.37	43.50	-32.13	QP
416.179	33.36	15.15	3.94	32.24	20.21	46.00	-25.79	QP
485.609	39.98	16.51	4.15	32.21	28.43	46.00	-17.57	QP
972.337	24.48	23.80	5.94	31.10	23.12	54.00	-30.88	QP

Test channel:	Highest	Polarization:	Vertical
---------------	---------	---------------	----------

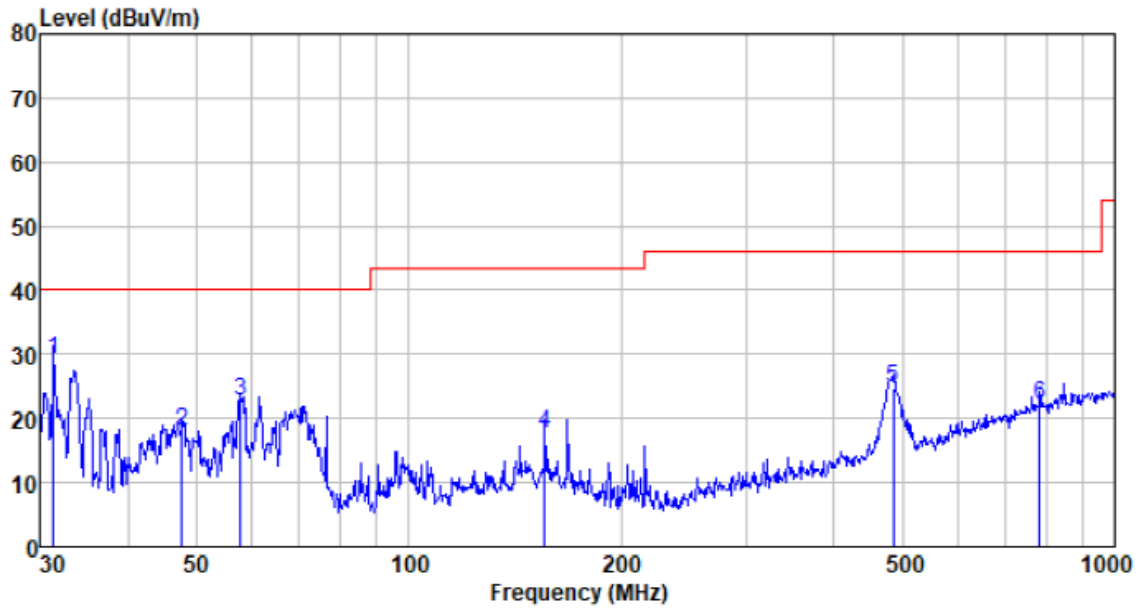

Freq MHz	Reading level dBuV	Antenna factor dB/m	Cable loss dB	Preamp factor dB	level dBuV/m	Limit level dBuV/m	Over limit dB	Remark
31.399	47.87	12.50	1.13	32.30	29.20	40.00	-10.80	QP
47.659	35.77	13.23	1.36	32.30	18.06	40.00	-21.94	QP
57.796	41.40	12.26	1.46	32.33	22.79	40.00	-17.21	QP
155.910	32.81	14.80	2.52	32.44	17.69	43.50	-25.81	QP
485.609	36.37	16.51	4.15	32.21	24.82	46.00	-21.18	QP
782.345	26.10	21.75	5.40	31.16	22.09	46.00	-23.91	QP

- Above 1GHz
- Unwanted Emissions in Non-restricted Frequency Bands
- All antennas have test, only the worst case ANT 1 report.

Test channel:	Lowest	Polarization:	Horizontal
---------------	--------	---------------	------------

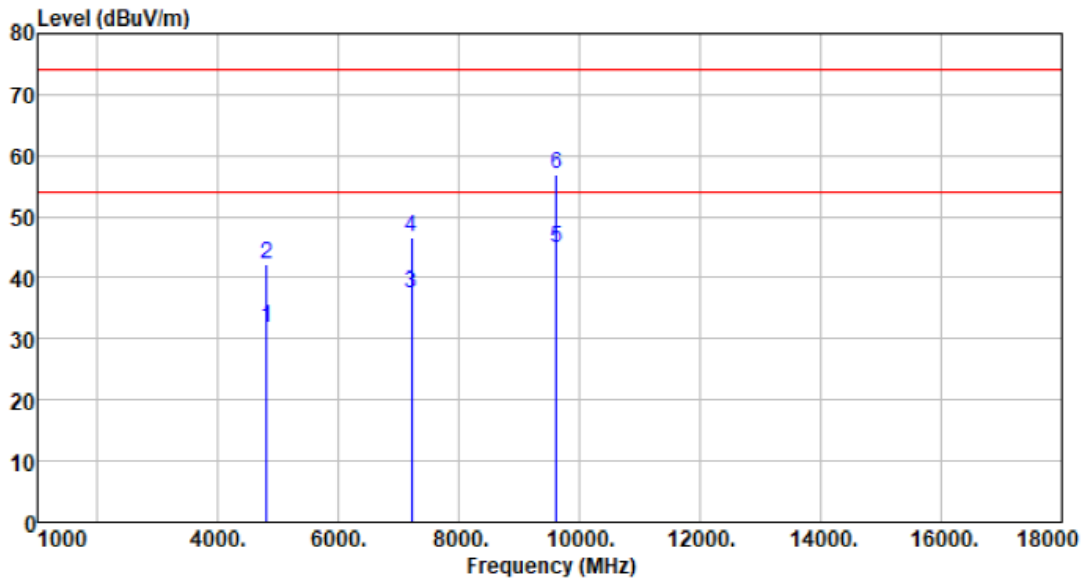

Freq MHz	Reading level dBuV	Antenna factor dB/m	Cable loss dB	Preamp factor dB	level dBuV/m	Limit level dBuV/m	Over limit dB	Remark
4804.300	32.48	32.01	6.01	38.54	31.96	54.00	-22.04	Average
4804.300	42.65	32.01	6.01	38.54	42.13	74.00	-31.87	Peak
7206.450	32.62	36.21	7.92	39.14	37.61	54.00	-16.39	Average
7206.450	41.58	36.21	7.92	39.14	46.57	74.00	-27.43	Peak
9608.600	32.16	38.20	14.86	40.22	45.00	54.00	-9.00	Average
9608.600	44.00	38.20	14.86	40.22	56.84	74.00	-17.16	Peak

Test channel:	Lowest	Polarization:	Vertical
---------------	--------	---------------	----------

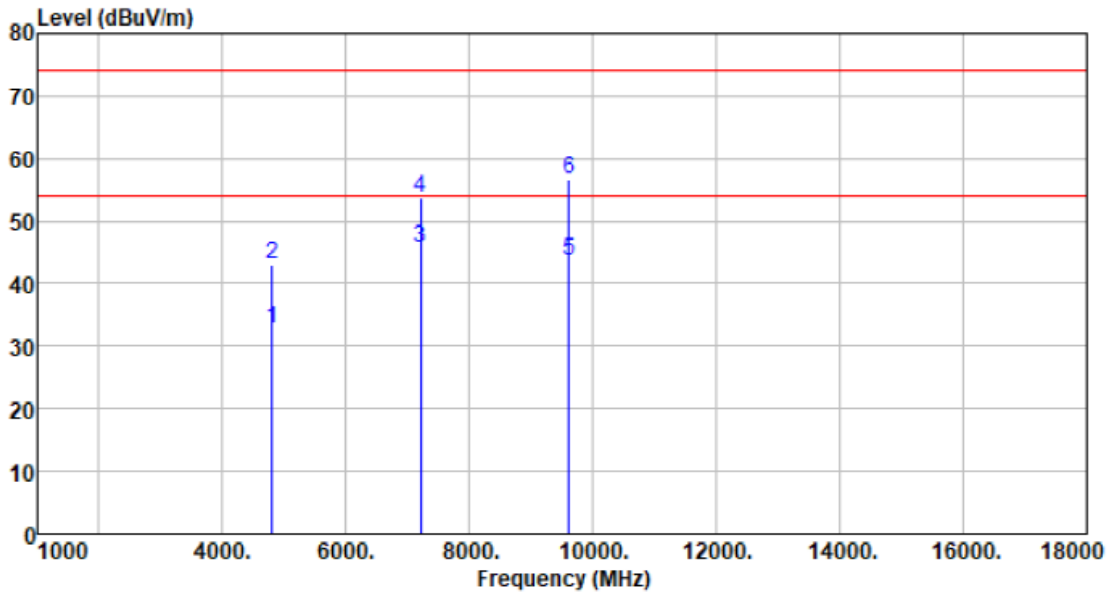

Freq MHz	Reading level dBuV	Antenna factor dB/m	Cable loss dB	Preamp factor dB	level dBuV/m	Limit level dBuV/m	Over limit dB	Remark
4804.300	33.41	32.01	6.01	38.54	32.89	54.00	-21.11	Average
4804.300	43.64	32.01	6.01	38.54	43.12	74.00	-30.88	Peak
7206.450	40.63	36.21	7.92	39.14	45.62	54.00	-8.38	Average
7206.450	48.80	36.21	7.92	39.14	53.79	74.00	-20.21	Peak
9608.600	30.95	38.20	14.86	40.22	43.79	54.00	-10.21	Average
9608.600	43.83	38.20	14.86	40.22	56.67	74.00	-17.33	Peak

Test channel:	Middle	Polarization:	Horizontal
---------------	--------	---------------	------------

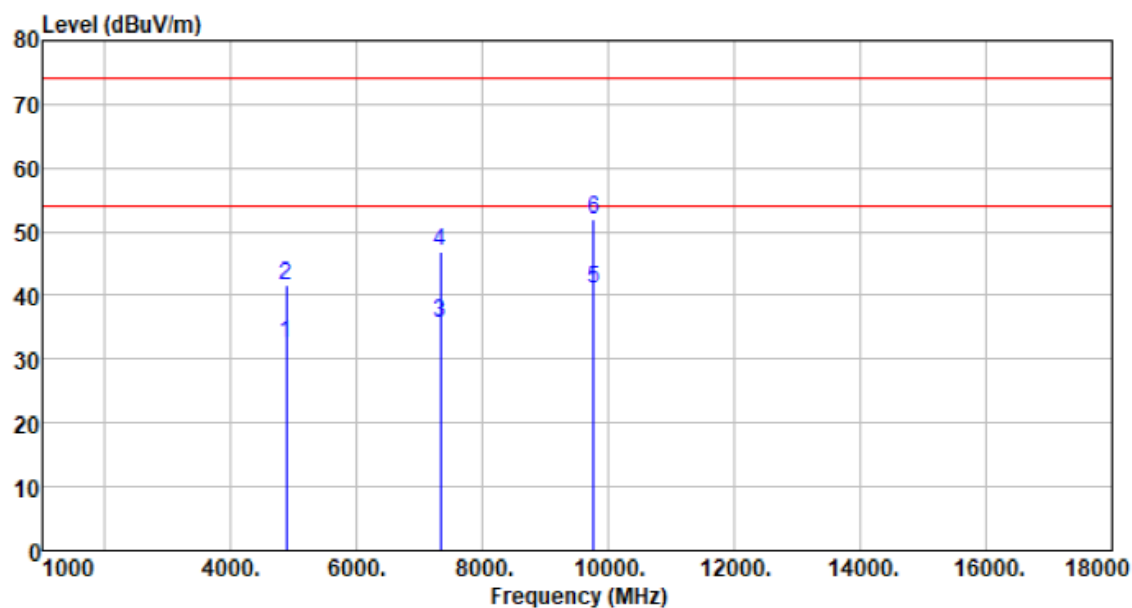

Freq MHz	Reading level dBuV	Antenna factor dB/m	Cable loss dB	Preamp factor dB	level dBuV/m	Limit level dBuV/m	Over limit dB	Remark
4880.800	32.82	32.10	6.03	38.52	32.43	54.00	-21.57	Average
4880.800	41.99	32.10	6.03	38.52	41.60	74.00	-32.40	Peak
7321.200	30.71	36.30	8.04	39.22	35.83	54.00	-18.17	Average
7321.200	41.84	36.30	8.04	39.22	46.96	74.00	-27.04	Peak
9761.600	31.69	38.20	11.31	40.25	40.95	54.00	-13.05	Average
9761.600	42.73	38.20	11.31	40.25	51.99	74.00	-22.01	Peak

Test channel:	Middle	Polarization:	Vertical
---------------	--------	---------------	----------

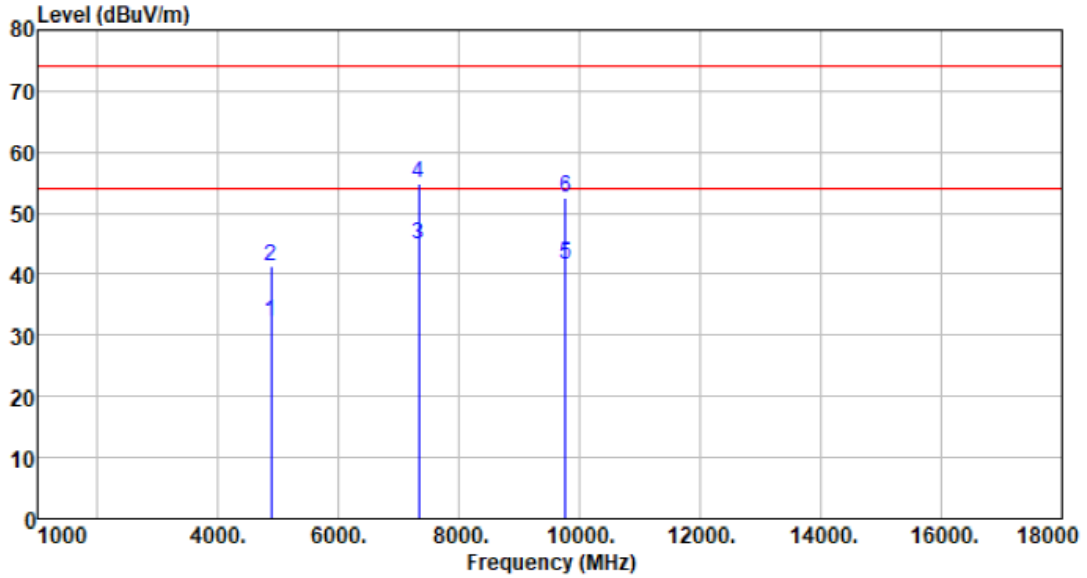

Freq MHz	Reading level dBuV	Antenna factor dB/m	Cable loss dB	Preamp factor dB	level dBuV/m	Limit level dBuV/m	Over limit dB	Remark
4880.800	32.66	32.10	6.03	38.52	32.27	54.00	-21.73	Average
4880.800	41.86	32.10	6.03	38.52	41.47	74.00	-32.53	Peak
7321.200	39.75	36.30	8.04	39.22	44.87	54.00	-9.13	Average
7321.200	49.94	36.30	8.04	39.22	55.06	74.00	-18.94	Peak
9761.600	32.51	38.20	11.31	40.25	41.77	54.00	-12.23	Average
9761.600	43.34	38.20	11.31	40.25	52.60	74.00	-21.40	Peak

Test channel:	Highest	Polarization:	Horizontal
---------------	---------	---------------	------------

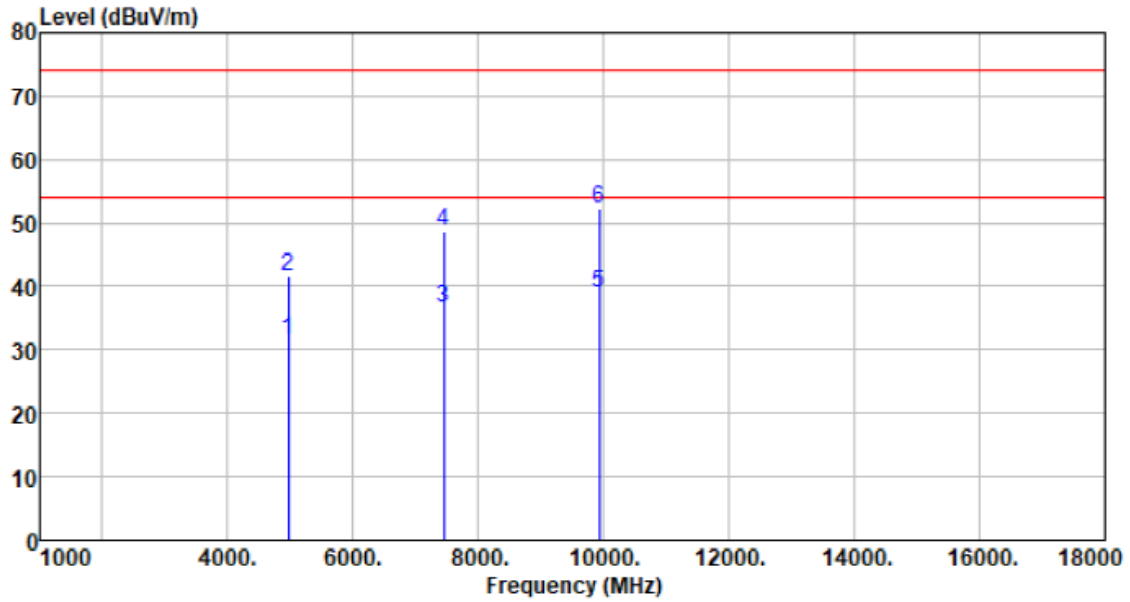

Freq MHz	Reading level dBuV	Antenna factor dB/m	Cable loss dB	Preamp factor dB	level dBuV/m	Limit level dBuV/m	Over limit dB	Remark
4959.700	31.95	32.20	6.05	38.51	31.69	54.00	-22.31	Average
4959.700	41.82	32.20	6.05	38.51	41.56	74.00	-32.44	Peak
7439.550	31.32	36.30	8.16	39.31	36.47	54.00	-17.53	Average
7439.550	43.53	36.30	8.16	39.31	48.68	74.00	-25.32	Peak
9919.400	30.39	38.24	10.76	40.28	39.11	54.00	-14.89	Average
9919.400	43.53	38.24	10.76	40.28	52.25	74.00	-21.75	Peak

Test channel:	Highest	Polarization:	Vertical
---------------	---------	---------------	----------

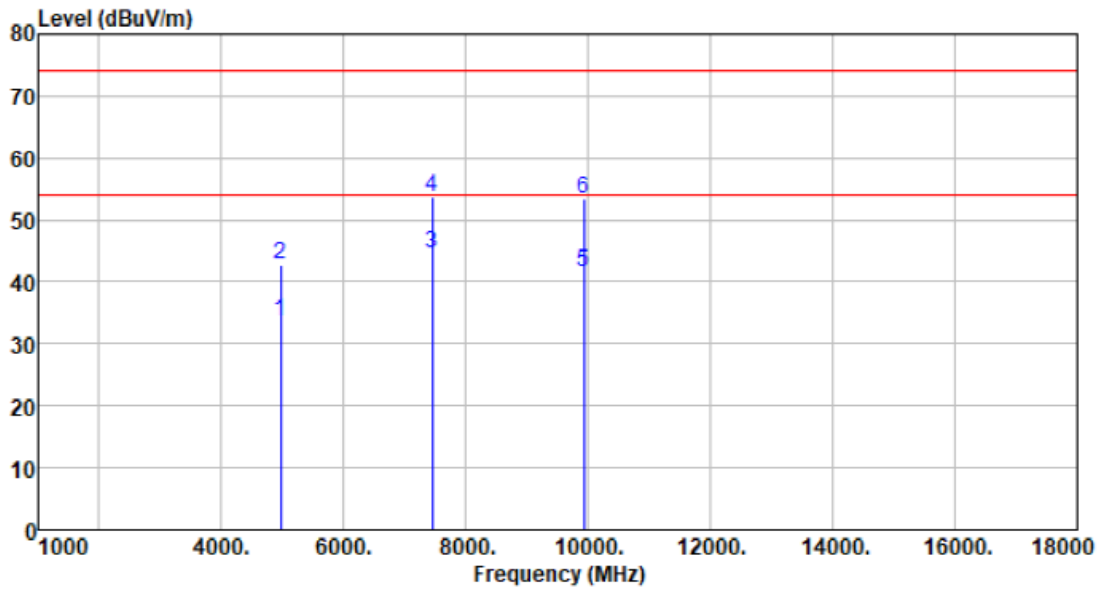

Freq MHz	Reading level dBuV	Antenna factor dB/m	Cable loss dB	Preamp factor dB	level dBuV/m	Limit level dBuV/m	Over limit dB	Remark
4959.700	33.79	32.20	6.05	38.51	33.53	54.00	-20.47	Average
4959.700	42.99	32.20	6.05	38.51	42.73	74.00	-31.27	Peak
7439.550	39.41	36.30	8.16	39.31	44.56	54.00	-9.44	Average
7439.550	48.65	36.30	8.16	39.31	53.80	74.00	-20.20	Peak
9919.400	32.82	38.24	10.76	40.28	41.54	54.00	-12.46	Average
9919.400	44.63	38.24	10.76	40.28	53.35	74.00	-20.65	Peak

Remark:

1. Final Level = Receiver Read level + Antenna Factor + Cable Loss – Preamplifier Factor
2. The emission levels of other frequencies are very lower than the limit and not show in test report.
3. For above 18GHz, no emission found.

■ Unwanted Emissions in Restricted Frequency Bands

■ ANT 1

Test channel:	Lowest	Polarization:	Horizontal
---------------	--------	---------------	------------

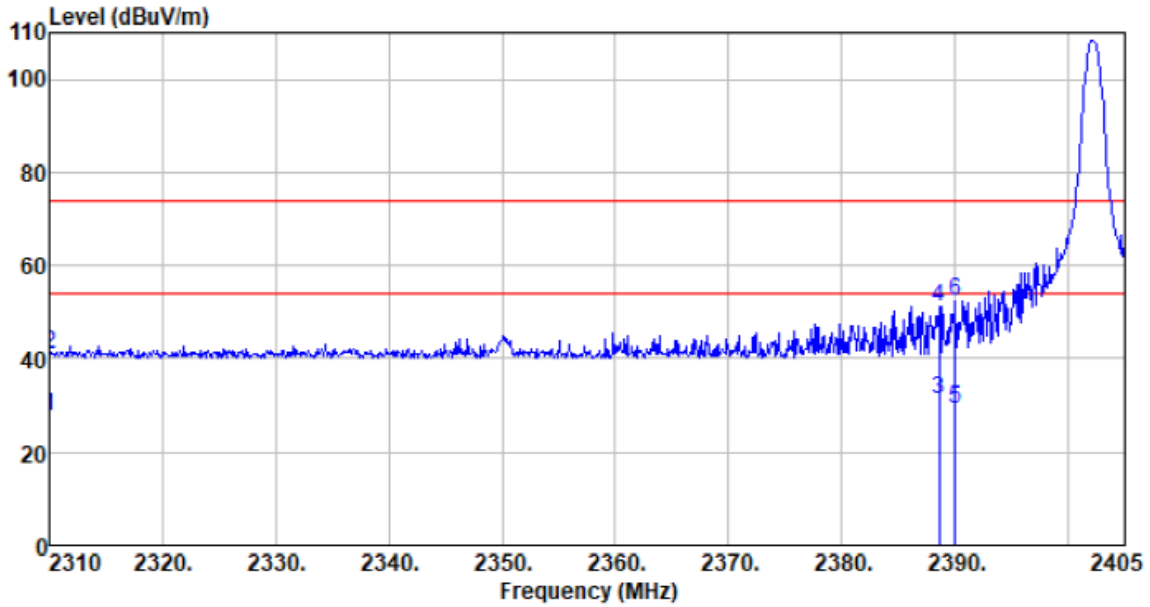

Freq MHz	Reading level dBuV	Antenna factor dB/m	Cable loss dB	Preamp factor dB	level dBuV/m	Limit level dBuV/m	Over limit dB	Remark
2310.000	35.54	27.00	4.13	39.14	27.53	54.00	-26.47	Average
2310.000	48.81	27.00	4.13	39.14	40.80	74.00	-33.20	Peak
2388.565	39.33	27.08	4.17	39.33	31.25	54.00	-22.75	Average
2388.565	59.40	27.08	4.17	39.33	51.32	74.00	-22.68	Peak
2390.000	37.33	27.08	4.17	39.34	29.24	54.00	-24.76	Average
2390.000	60.26	27.08	4.17	39.34	52.17	74.00	-21.83	Peak

Test channel:	Lowest	Polarization:	Vertical
---------------	--------	---------------	----------

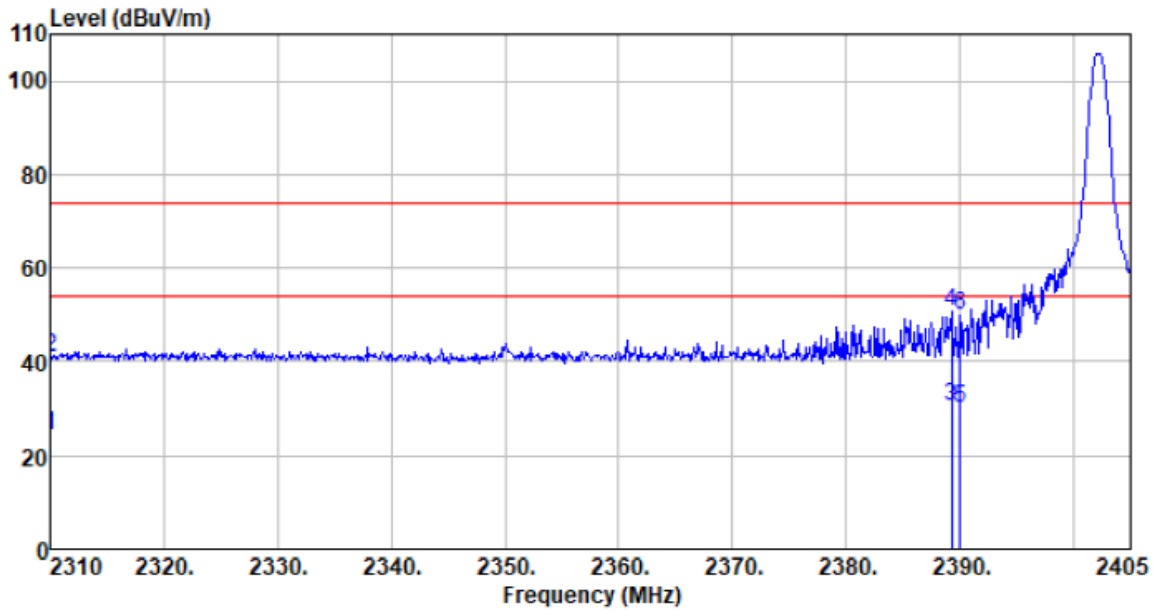

Freq MHz	Reading level dBuV	Antenna factor dB/m	Cable loss dB	Preamp factor dB	level dBuV/m	Limit level dBuV/m	Over limit dB	Remark
2310.000	32.19	27.00	4.13	39.14	24.18	54.00	-29.82	Average
2310.000	49.09	27.00	4.13	39.14	41.08	74.00	-32.92	Peak
2389.230	38.57	27.08	4.17	39.33	30.49	54.00	-23.51	Average
2389.230	58.62	27.08	4.17	39.33	50.54	74.00	-23.46	Peak
2390.000	38.16	27.08	4.17	39.34	30.07	54.00	-23.93	Average
2390.000	58.05	27.08	4.17	39.34	49.96	74.00	-24.04	Peak

Test channel:	Highest	Polarization:	Horizontal
---------------	---------	---------------	------------

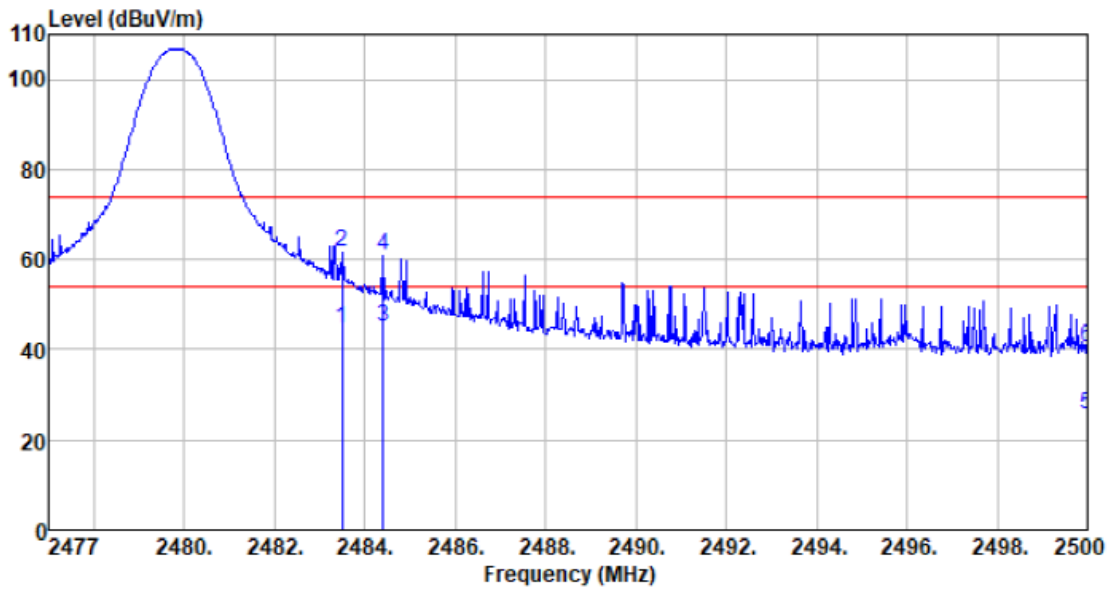

Freq MHz	Reading level dBuV	Antenna factor dB/m	Cable loss dB	Preamp factor dB	level dBuV/m	Limit level dBuV/m	Over limit dB	Remark
2483.500	52.84	27.27	4.08	39.56	44.63	54.00	-9.37	Average
2483.500	69.74	27.27	4.08	39.56	61.53	74.00	-12.47	Peak
2484.406	53.17	27.27	4.08	39.56	44.96	54.00	-9.04	Average
2484.406	69.01	27.27	4.08	39.56	60.80	74.00	-13.20	Peak
2500.000	33.72	27.30	4.06	39.60	25.48	54.00	-28.52	Average
2500.000	48.85	27.30	4.06	39.60	40.61	74.00	-33.39	Peak

Test channel:	Highest	Polarization:	Vertical
---------------	---------	---------------	----------

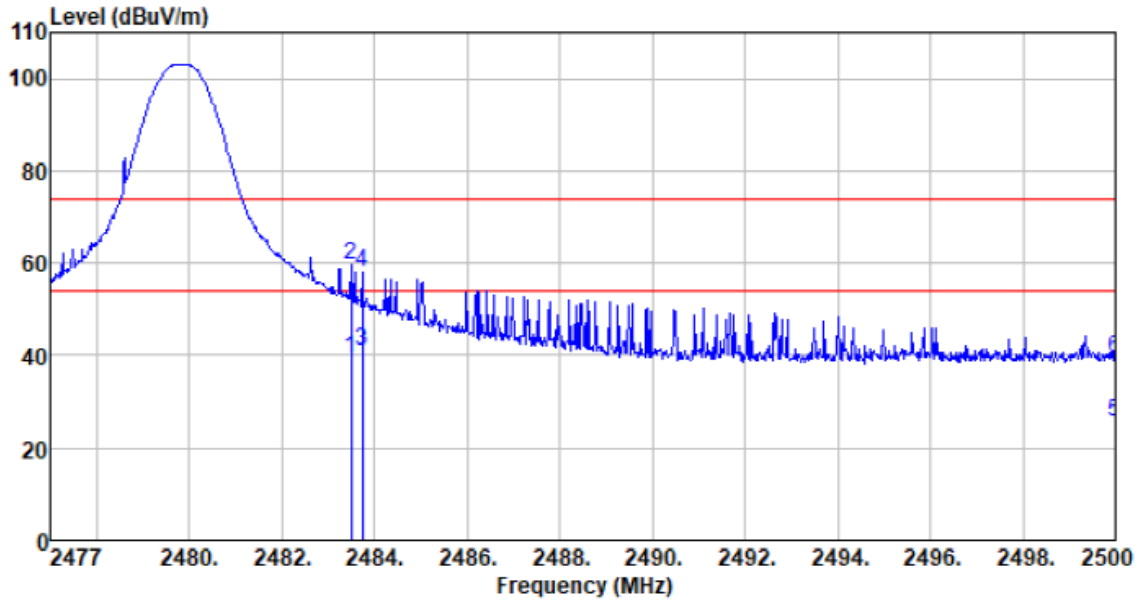

Freq MHz	Reading level dBuV	Antenna factor dB/m	Cable loss dB	Preamp factor dB	level dBuV/m	Limit level dBuV/m	Over limit dB	Remark
2483.500	47.41	27.27	4.08	39.56	39.20	54.00	-14.80	Average
2483.500	67.68	27.27	4.08	39.56	59.47	74.00	-14.53	Peak
2483.739	49.36	27.27	4.08	39.56	41.15	54.00	-12.85	Average
2483.739	66.26	27.27	4.08	39.56	58.05	74.00	-15.95	Peak
2500.000	33.83	27.30	4.06	39.60	25.59	54.00	-28.41	Average
2500.000	47.64	27.30	4.06	39.60	39.40	74.00	-34.60	Peak

■ ANT 2

Test channel:	Lowest	Polarization:	Horizontal
---------------	--------	---------------	------------

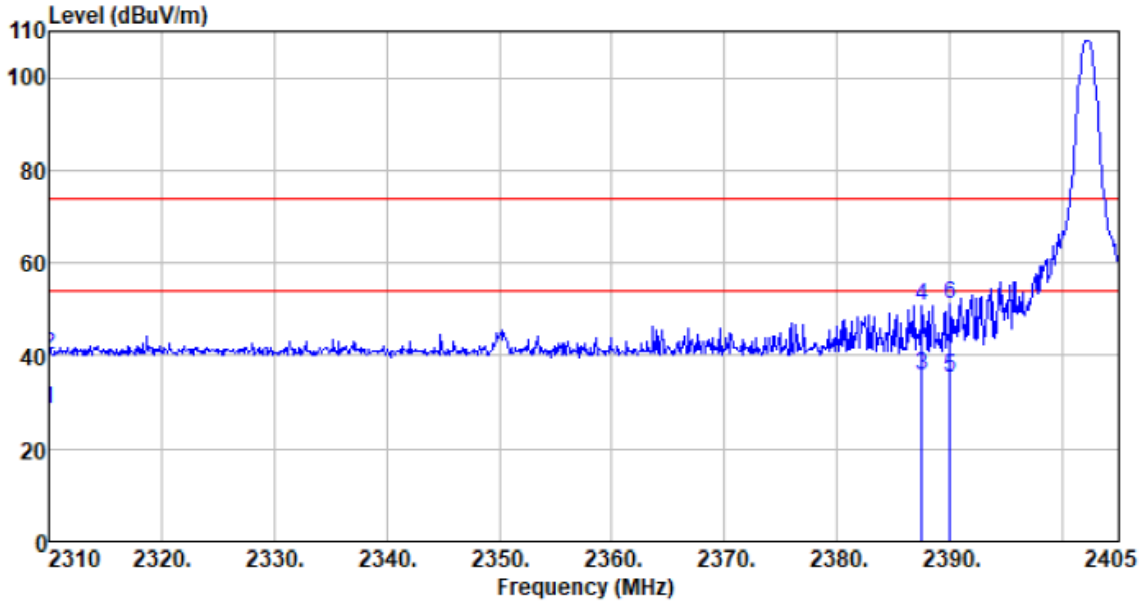

Freq MHz	Reading level dBuV	Antenna factor dB/m	Cable loss dB	Preamp factor dB	level dBUV/m	Limit level dBUV/m	Over limit dB	Remark
2310.000	36.51	27.00	4.13	39.14	28.50	54.00	-25.50	Average
2310.000	48.34	27.00	4.13	39.14	40.33	74.00	-33.67	Peak
2387.520	43.76	27.08	4.17	39.33	35.68	54.00	-18.32	Average
2387.520	58.94	27.08	4.17	39.33	50.86	74.00	-23.14	Peak
2390.000	43.36	27.08	4.17	39.34	35.27	54.00	-18.73	Average
2390.000	59.29	27.08	4.17	39.34	51.20	74.00	-22.80	Peak

Test channel:	Lowest	Polarization:	Vertical
---------------	--------	---------------	----------

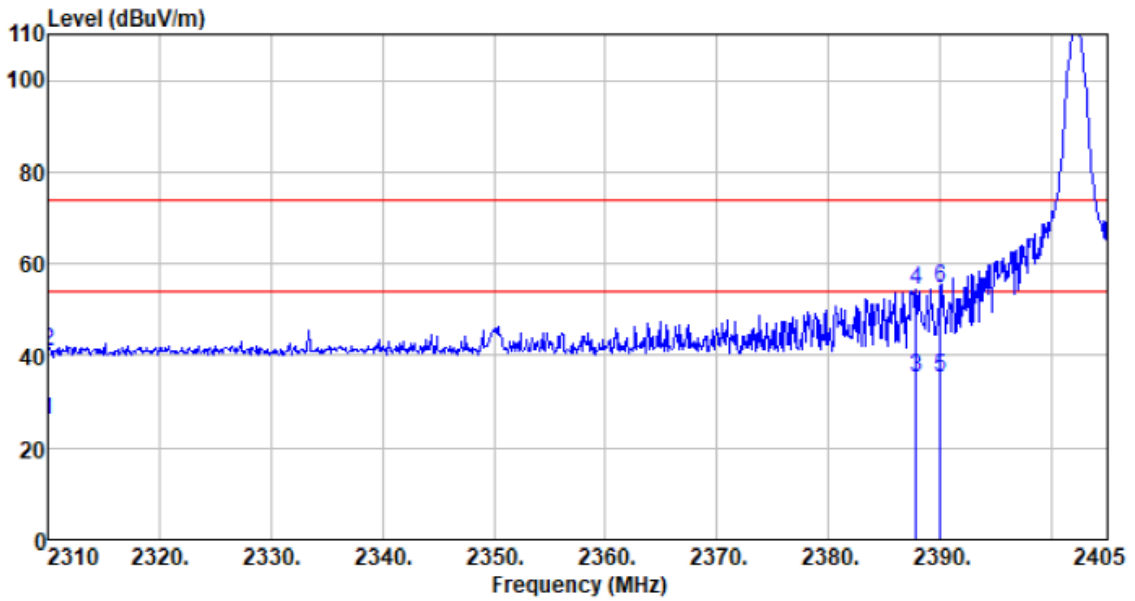

Freq MHz	Reading level dBuV	Antenna factor dB/m	Cable loss dB	Preamp factor dB	level dBuV/m	Limit level dBuV/m	Over limit dB	Remark
2310.000	33.80	27.00	4.13	39.14	25.79	54.00	-28.21	Average
2310.000	48.86	27.00	4.13	39.14	40.85	74.00	-33.15	Peak
2387.805	43.34	27.08	4.17	39.33	35.26	54.00	-18.74	Average
2387.805	62.59	27.08	4.17	39.33	54.51	74.00	-19.49	Peak
2390.000	43.45	27.08	4.17	39.34	35.36	54.00	-18.64	Average
2390.000	62.70	27.08	4.17	39.34	54.61	74.00	-19.39	Peak

Test channel:	Highest	Polarization:	Horizontal
---------------	---------	---------------	------------

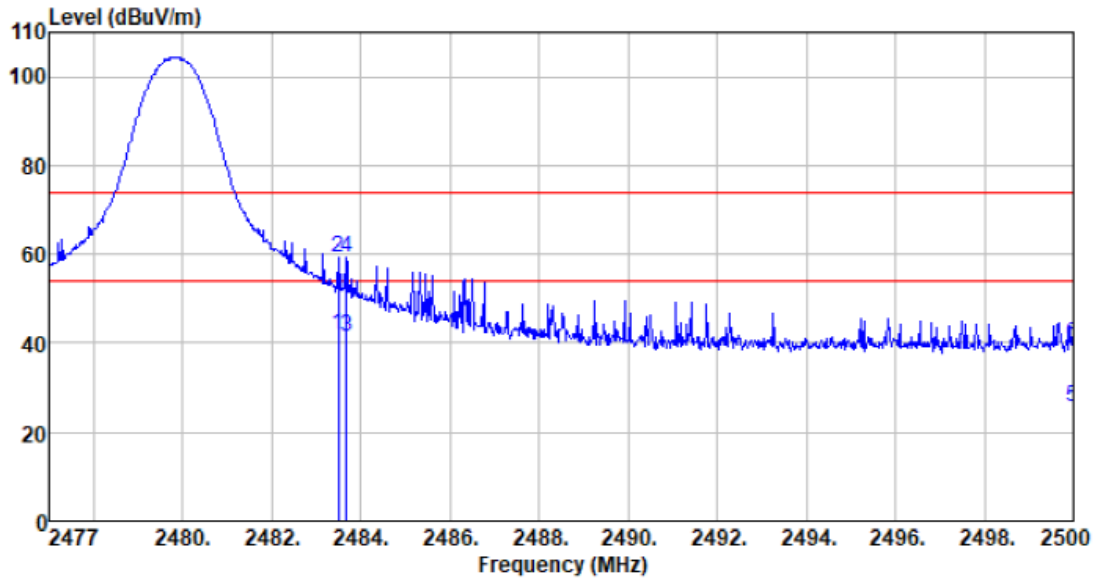

Freq MHz	Reading level dBuV	Antenna factor dB/m	Cable loss dB	Preamp factor dB	level dBuV/m	Limit level dBuV/m	Over limit dB	Remark
2483.500	50.13	27.27	4.08	39.56	41.92	54.00	-12.08	Average
2483.500	67.35	27.27	4.08	39.56	59.14	74.00	-14.86	Peak
2483.670	49.41	27.27	4.08	39.56	41.20	54.00	-12.80	Average
2483.670	67.55	27.27	4.08	39.56	59.34	74.00	-14.66	Peak
2500.000	33.83	27.30	4.06	39.60	25.59	54.00	-28.41	Average
2500.000	47.93	27.30	4.06	39.60	39.69	74.00	-34.31	Peak

Test channel:	Highest	Polarization:	Vertical
---------------	---------	---------------	----------

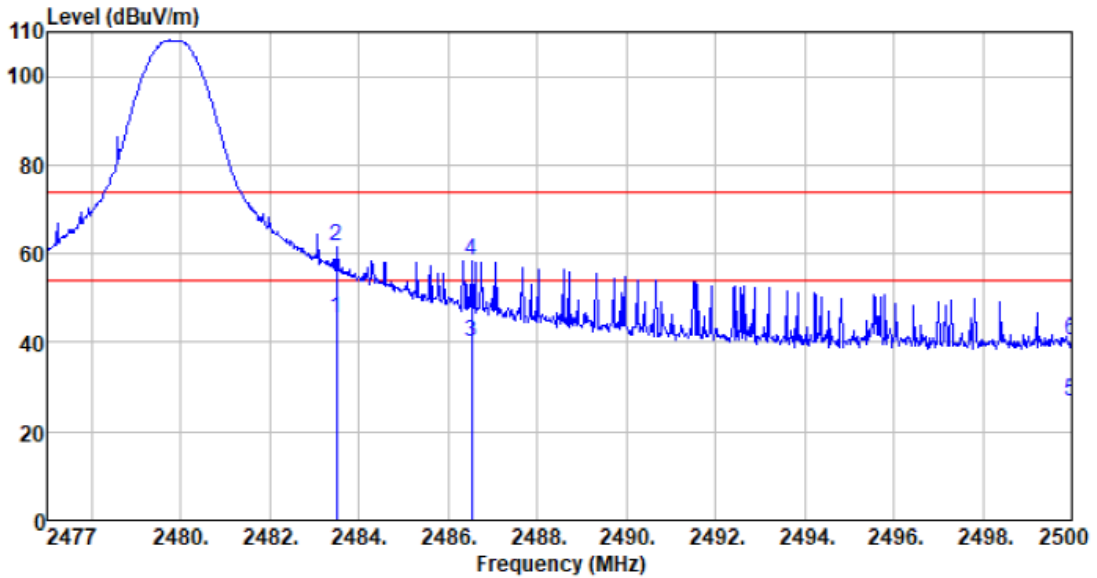

Freq MHz	Reading level dBuV	Antenna factor dB/m	Cable loss dB	Preamp factor dB	level dBuV/m	Limit level dBuV/m	Over limit dB	Remark
2483.500	53.57	27.27	4.08	39.56	45.36	54.00	-8.64	Average
2483.500	69.74	27.27	4.08	39.56	61.53	74.00	-12.47	Peak
2486.522	48.46	27.27	4.08	39.57	40.24	54.00	-13.76	Average
2486.522	66.60	27.27	4.08	39.57	58.38	74.00	-15.62	Peak
2500.000	34.90	27.30	4.06	39.60	26.66	54.00	-27.34	Average
2500.000	48.74	27.30	4.06	39.60	40.50	74.00	-33.50	Peak

Remarks:

1. Final Level = Receiver Read level + Antenna Factor + Cable Loss – Pre-amplifier Factor
2. The emission levels of other frequencies are very lower than the limit and not show in test report.

8 Test Setup Photo

Reference to the **appendix I** for details.

9 EUT Constructional Details

Reference to the **appendix II** for details.

---End---