

承认书

SPECIFICATION FOR APPROVEAL

客户名称(CUSTOMER) : ZLGD-A1-0338

客户料号(PART NO.) : ZLGD-Y14X38.5-100-FR

品名(DESCRIPTION) : 线圈+磁片 Coil + diskette

规格(SPECIFICATION) : 14x38.5,0.08x105P Silk-covered wire with magnetic edge 100MM

日期 DATE) : 20240613

本司确认 (TRX APPROVAL)		
制作	审核	承认日期
曾小仙	邱志辉	20240613
客户确认 (CUSTOMER APPROVAL)		
工程	批准	承认日期
确认结果(Result):	<input type="checkbox"/> 合格	<input type="checkbox"/> 不合格 <input type="checkbox"/> 其它

东莞市德弗力五金电子材料有限公司

Dongguan city DFL Electronic Technology Co.,LTD

东莞市石碣镇新风西路107号

电话: 0769-86016320 传真: 0769-86372427

东莞市德弗力五金电子材料有限公司
Dongguan city DFL Electronic Technology Co.,LTD

SPECIFICATION

产品型号: DESC	ZLGD-Y14X38. 5-100-FR	版本 Rev:C	Customer:	ZLGD-A1-0338
			Description:	Coil + diskette
			Date:	20240613

一、尺寸DIMENSION:(mm)

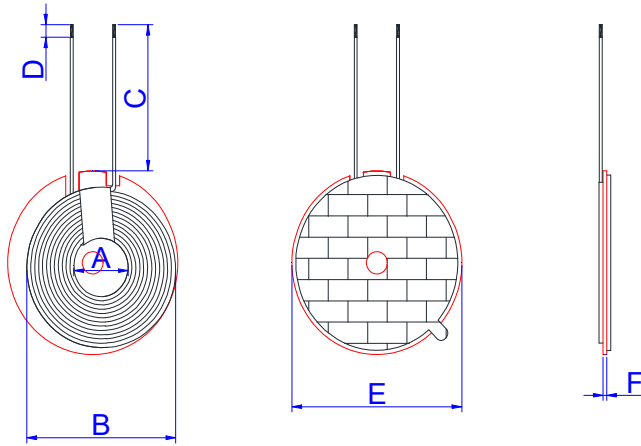

A	14.0±1.0
B	38.5±1.5
C	100 +3.0
D	3.0±2.0
E	44.0±1.0
F	0.8±0.2
G	
H	
I	
J	
K	
L	
M	
N	
O	
P	

Note:

1. Wire bonding G44 0.8 hard magnetic
2. Wrap 8MM high-temperature tape around the cable exit position
3. Attach double-sided tape with ear on the back of the magnetic disc
4. The thread is crookedy5. Do not loosen the thread

二、

天线增益 Antenna gain:

Operation frequency:	113kHz-205kHz
Antenna Type:	Loop coil Antenna
Antenna gain:	0dBi

三、绕线参数(WindingSpecification:)

序号 NO.	端子 TERMINAL	线径 WIRE	圈数 Turns	绕线方向 Winding Direction
1		0.08×105P silk-covered wire	12TS	anticlockwise

四、电气特性 ELECTRICAL CHARACTERISTICS:

温度 TEMPERATURE:25±10°C,湿度 RELATIVE HUMIDITY:65±20%

序号 NO.	项目 ITEM	端子 TERMINAL	标准 SPECIFICATION	测试条件 TEST FREQUENCY	测试仪器 TEST EQUIPMENTS
1	IND.		6.8uH±0.3 Magnetized sheet	100KHz/1.0V	SHDA 1062
2	IND.				
3	Q value				
4	DCR				

拟制/日期PREPARED BY/DATE	审核/日期CHECKED BY/DATE	客户/日期CUSTOMEU/DATE