

# 承 认 书

## SPECIFICATION FOR APPROVAL

客 户: 中利冠达（深圳）智能科技有限公司（KH008）  
CUSTOMER:

---

客 户 料 号: L8  
CUST P/N:

---

内 部 料 号: LCX-KH008TX010  
LCX P/N:

---

产 品 型 号:  $\Phi 21.7*39-0.08*72P-11TS-29-42.42LC-BJ$   
DESC:

---

日 期: 2024/4/30  
DATE:

---

版 本: A.0  
Version:

---

制作 PREPARED BY	审核 CHECKED BY	批准 APPROVED BY	客户承认 CUSTOMER APPROVE
杨文俊 2024/4/30	高应洪 2024/4/30		

地 址: 深圳市龙华区观湖街道观城社区横坑村440号荣倡工业园7B栋四楼401

电 话: 13828741697

E-mail: 467317369@qq.com

产品规格书 SPECIFICATION		版本 A/0	制作: 杨文俊 2024/4/30	审核: 高应洪 2024/4/30
图纸编号: LCX-GCQP001168		页码: 2/4	客户代码: CUST	KH008
规格型号	Φ21.5*39-0.08*72P-11TS-29-42.42LOC-BJ	客户料号: CUST P/N		L8
		内部料号: IN P/N		LXC-KH008TX010

## 版本变更履历

### Version Change History

版本 Rev	变更前 Before Change	变更后 After Change	更改日期 Change Date	批准 Approved By
A/0	新发行	-----	2024/4/30	高应洪

## 物料清单

### Bill of material

序号 NO	物料名称 name of material	内部料号 Internal part number	物料规格 Material specification	单位 unit	dosage	备注 remark
1	线圈 Coil		Multi-strand enamelled wire 0.08*72P	g	4.1	
2	硬磁片 Hard disk		Φ42.4*0.65Material PN40	PCS	1	Double slot without hole
3	硬磁片 Hard disk		Φ18*0.8 Material PN40	PCS	1	
4	Common double-sided tape		Φ41.5*0.03	PCS	1	Double-sided back tape hand tear
5	无铅锡条 Lead-free tin strip		Su 99.3 Cu 0.7	g		
6	黄胶 Yellow gum		405	g		
7	high-temperature tape		Width 5 x length 8	PCS	1	
		以下空白				

产品规格书 SPECIFICATION								版本 A/0	制作: 杨文俊 2024/4/30	审核: 高应洪 2024/4/30					
图纸编号: LCX-GCQP001168								页码: 3/4	客户代码: CUST	KH008					
规格型号 $\Phi 21.7 \times 39 - 0.08 \times 72P - 11TS - 29 - 42.42LOC - BJ$								客户料号: CUST P/N				L8			
								内部料号: IN P/N				LXC-KH008TX010			
A	B	C	D	E	F	H	H1	H2	--	--	--	--	--	--	
39 -40	21.7 $\pm 0.5$	42.5+0/ -0.5	17.7 Ref	28.6- 30	3 $\pm 1$	0.7 $\pm 0.1$	0.65 $\pm 0.05$	1.6 Max	--	--	--	--	--	--	

一、尺寸 DIMENSION:(mm) 绕线模具: $\Phi 21.7$  线圈单重: 4.1

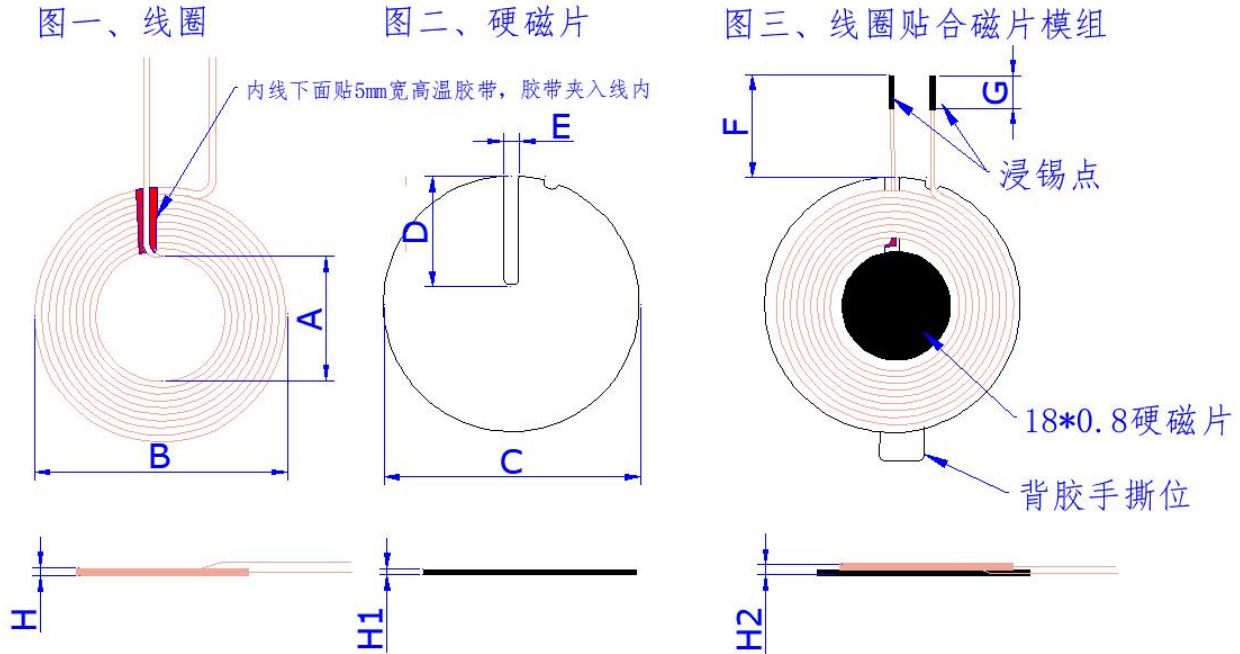

Note:

- Coil winding clockwise, as shown in Figure 1, coil can not scatter, loose, lead does not cross the wire out, stick 5mm wide warm tape under the inner wire.
- Magnetic disc as shown in Figure 2, specifications: 42.4\*0.65 double slot without hole
- As shown in Figure 3, the coil is reversed. The inner wire is routed from the slot of the magnetic disc, and the outer wire is slightly connected to the magnetic disc.
- The coil front magnetic disc is affixed with small magnetic disc in the middle, specification: 18\*0.8, the reverse side is affixed with ordinary double-sided tape specification: 41.5\*0.03, with hand tear.

二、原理图 SCHEMATIC DIAGRAM:

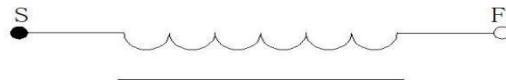

三、绕线参数 Winding Specification:

序号 NO	端子 TERMINAL		线径 WIRE	线材分解温度 Temperature	圈数 Turns	绕线方向 Winding Direction
L1	S	F	Multi-strand enamelled wire 0.08*72P	180-250 degrees	11TS	clockwise

四、电气特性 ELECTRICAL CHARACTERISTIC: :

温度 TEMPERATURE: 25 $\pm$ 10 $^{\circ}$ C, 湿度 RELATIVE HUMIDITY: 65 $\pm$ 20%

序号	磁片材质 Disk material	电感量 LS	阻抗 DCR	测试条件 TEST FREQUENCY	测试仪器 TEST EQUIPMENTS
1	/	4.5uH $\pm$ 10% (单线圈) Single coil	58m $\Omega$ $\pm$ 10%	100KHz/1.0V	U2832
2	硬磁片 Hard disk	8.3 $\pm$ 0.3uH (贴合磁片) Fit magnetic disc	58m $\Omega$ $\pm$ 10%	100KHz/1.0V	U2832

产品规格书 <u>SPECIFICATION</u>		版本 A/0	制作：杨文俊 2024/4/30	审核：高应洪 2024/4/30
		页码：4/4	客户代码： CUST	KH008
图纸编号： LCX-GCQP001168	规格型号 $\Phi 21.7*39-0.08*72P-11TS-29-42.42LOC-BJ$		客户料号： CUST P/N	L8
			内部料号： IN P/N	LXC-KH008TX010

天线增益 Antenna gain:

Operation frequency:	113kHz-205kHz
Antenna Type:	Loop coil Antenna
Antenna gain:	0dBi