

TEST REPORT

Product Name : UVC Disinfection Robot
Model Number : FJDT02UV
FCC ID : 2A2LLFJDT02UV

Prepared for : FJ Dynamics Co., Ltd.
Address : 1709, WeiXing Building., 61 GaoXin South 9th Rd.,
Nanshan District, Shenzhen, China

Prepared by : EMTEK (SHENZHEN) CO., LTD.
Address : Building 69, Majialong Industry Zone, Nanshan District,
Shenzhen, Guangdong, China

Tel: (0755) 26954280
Fax: (0755) 26954282

Report Number : ENS2203310211W01001R
Date(s) of Tests : March 31, 2022 to May 14, 2022
Date of issue : May 27, 2022

TABLE OF CONTENTS

1 TEST RESULT CERTIFICATION	3
2 EUT TECHNICAL DESCRIPTION	4
3 SUMMARY OF TEST RESULT	5
4 TEST METHODOLOGY	6
4.1 GENERAL DESCRIPTION OF APPLIED STANDARDS	6
4.2 MEASUREMENT EQUIPMENT USED	6
4.3 DESCRIPTION OF TEST MODES	8
5 FACILITIES AND ACCREDITATIONS	9
5.1 FACILITIES	9
5.2 EQUIPMENT	9
5.3 LABORATORY ACCREDITATIONS AND LISTINGS	9
6 TEST SYSTEM UNCERTAINTY	10
7 SETUP OF EQUIPMENT UNDER TEST	11
7.1 RADIO FREQUENCY TEST SETUP 1	11
7.2 RADIO FREQUENCY TEST SETUP 2	11
7.3 CONDUCTED EMISSION TEST SETUP	12
7.4 BLOCK DIAGRAM CONFIGURATION OF TEST SYSTEM	13
7.5 SUPPORT EQUIPMENT	13
8 TEST REQUIREMENTS	14
8.1 DTS(6DB)BANDWIDTH	14
8.2 MAXIMUM PEAK CONDUCTED OUTPUT POWER	26
8.3 MAXIMUM POWER SPECTRAL DENSITY	38
8.4 UNWANTED EMISSIONS IN NON-RESTRICTED FREQUENCY BANDS	50
8.5 RADIATED SPURIOUS EMISSION	65
8.6 CONDUCTED EMISSIONS TEST	77
8.7 ANTENNA APPLICATION	80

1 TEST RESULT CERTIFICATION

Applicant : FJ Dynamics Co., Ltd.
 Address : 1709, WeiXing Building., 61 GaoXin South 9th Rd., Nanshan District, Shenzhen, China
 Manufacturer : FJ Dynamics Co., Ltd.
 Address : 1709, WeiXing Building., 61 GaoXin South 9th Rd., Nanshan District, Shenzhen, China
 EUT : UVC Disinfection Robot
 Model Name : FJDT02UV
 Trademark : FJDynamics

Measurement Procedure Used:

APPLICABLE STANDARDS	
STANDARD	TEST RESULT
FCC 47 CFR Part 2 , Subpart J FCC 47 CFR Part 15 , Subpart C	PASS

The above equipment was tested by EMTEK (SHENZHEN) CO., LTD. The test data, data evaluation, test procedures, and equipment configurations shown in this report were made in accordance with the procedures given in ANSI C63.10 (2013) and the energy emitted by the sample EUT tested as described in this report is in compliance with the requirements of FCC Rules Part 2 and Part 15.247

The test results of this report relate only to the tested sample identified in this report.

Date of Test : March 31, 2022 to May 14, 2022

Prepared by : 
 Una Yu /Editor

Reviewer : 
 Joe Xia /Supervisor

Approve & Authorized Signer : 
 Lisa Wang/Manager



2 EUT TECHNICAL DESCRIPTION

Characteristics	Description
Product:	UVC Disinfection Robot
Model Number:	FJDT02UV
Sample Number:	2#
IEEE 802.11 WLAN Mode Supported	<input checked="" type="checkbox"/> 802.11b(20MHz channel bandwidth) <input checked="" type="checkbox"/> 802.11g(20MHz channel bandwidth) <input checked="" type="checkbox"/> 802.11n(20MHz channel bandwidth) <input type="checkbox"/> 802.11ax(20MHz channel bandwidth) <input checked="" type="checkbox"/> 802.11n(40MHz channel bandwidth)
Modulation	<input checked="" type="checkbox"/> DSSS with DBPSK/DQPSK/CCK for 802.11b; <input checked="" type="checkbox"/> OFDM with BPSK/QPSK/16QAM/64QAM for 802.11g/n <input type="checkbox"/> OFDMA with BPSK/QPSK/16QAM/64QAM for 802.11ax;
Operating Frequency Range	<input checked="" type="checkbox"/> 2412-2462MHz for 802.11b/g; <input checked="" type="checkbox"/> 2412-2462MHz for 802.11n(HT20) <input checked="" type="checkbox"/> 2422-2452MHz for 802.11n(HT40)
Number of Channels	<input checked="" type="checkbox"/> 11 channels for 802.11b/g; <input checked="" type="checkbox"/> 11 channels for 802.11n(HT20) <input checked="" type="checkbox"/> 9 channels for 802.11n(HT40)
Antenna Type	Internal Antenna
Antenna Gain	ANT 1/ANT 2: 0.8 dBi (with cable loss)
Transmit Power:	SISO: 14.32dBm MIMO:16.58 dBm
Power supply	Adapter: AC 100-240V, 50/60Hz Internal battery: DC 25.6V
Date of Received	March 31, 2022
Temperature Range	0°C ~ +50°C

Note: for more details, please refer to the User's manual of the EUT.

3 SUMMARY OF TEST RESULT

FCC PartClause	Test Parameter	Verdict	Remark
15.247(a)(2)	DTS (6dB) Bandwidth	PASS	
15.247(b)(3)	Maximum Peak Conducted Output Power	PASS	
15.247(e)	Maximum Power Spectral Density Level	PASS	
15.247(d)	Unwanted Emission Into Non-Restricted Frequency Bands	PASS	
15.247(d) 15.209	Unwanted Emission Into Restricted Frequency Bands (conducted)	PASS	
15.247(d) 15.209	Radiated Spurious Emission	PASS	
15.207	Conducted Emission Test	PASS	
15.247(b)	Antenna Application	PASS	
	NOTE1:N/A (Not Applicable) NOTE2: According to FCC OET KDB 558074, the report use radiated measurements in the restricted frequency bands. In addition, the radiated test is also performed to ensure the emissions emanating from the device cabinet also comply with the applicable limits.		

RELATED SUBMITTAL(S) / GRANT(S):

This submittal(s) (test report) is intended for FCC ID: 2A2LLFJDT02UV filing to comply with Section 15.247 of the FCC Part 15, Subpart C Rules.

4 TEST METHODOLOGY

4.1 GENERAL DESCRIPTION OF APPLIED STANDARDS

According to its specifications, the EUT must comply with the requirements of the following standards:

FCC 47 CFR Part 2, Subpart J

FCC 47 CFR Part 15, Subpart C

FCC KDB 558074 D01 15.247 Meas Guidance v05r02

FCC KDB 662911 D01 Multiple Transmitter Output v02r01

4.2 MEASUREMENT EQUIPMENT USED

Conducted Emission Test Equipment

Equipment	Manufacturer	Model No.	Serial No.	Last Cal.	Cal. Interval
Test Receiver	Rohde & Schwarz	ESCI	101384	May 15, 2021	1 Year
L.I.S.N.	Rohde & Schwarz	ENV216	5	May 15, 2021	1 Year
L.I.S.N.	Kyoritsu	KNW-407	8-1492-9	May 16, 2021	1 Year
Absorbing Clamp	Rohde & Schwarz	MDS-21	833711/025	May 15, 2021	1 Year
Loop antenna	Laplace	RF300	8006	May 15, 2021	1 Year
Van der Hoofden test-head	Schwarzbeck	VDHH 9502	9502-054	May 15, 2021	1 Year
Pulse Limiter	Rohde & Schwarz	ESH3-Z2	100107	May 15, 2021	1 Year

For Spurious Emissions Test

Equipment	Manufacturer	Model No.	Serial No.	Last Cal.	Cal. Interval
EMI Test Receiver	Rohde & Schwarz	ESU 26	100154	May 15, 2021	1 Year
Pre-Amplifie	Lunar EM	LNA30M3G-25	J10100000070	May 15, 2021	1 Year
Bilog Antenna	Schwarzbeck	VULB9163	659	Aug. 22, 2021	2 Year
Horn antenna	Schwarzbeck	BBHA9120D	9120D-1177	July 04, 2020	2 Year
Pre-Amplifie	SKET	LNPA_0118G-45	SK2019051801	May 15, 2021	1 Year
Loop Antenna	Schwarzbeck	FMZB1519	1519-012	June 12, 2021	2 Year
Spectrum Analyzer	Rohde & Schwarz	FSV40	100967	May 15, 2021	1 Year
Horn antenna	Schwarzbeck	BBHA9120D	9120D-1178	July 04, 2020	2 Year
Bilog Antenna	Schwarzbeck	VULB9163	660	June 12, 2021	2 Year
Cable	H+B	NmSm-05-C15052	N/A	May 15, 2021	1 Year
Cable	H+B	NmSm-2-C15201	N/A	May 15, 2021	1 Year
Cable	H+B	NmNm-7-C15702	N/A	May 15, 2021	1 Year
Cable	H+B	SAC-40G-1	414	May 15, 2021	1 Year
Cable	H+B	SUCOFLEX104	MY14871/4	May 15, 2021	1 Year
Cable	H+B	BLU18A-NmSm-6500	D8501	May 15, 2021	1 Year
Band reject Filter(50dB)	WI/DE	WRCGV-2400(2400-2485MHz)	2	May 15, 2021	1 Year

For other test items:

Equipment	Manufacturer	Model No.	Serial No.	Last Cal.	Cal. Interval
Vector Signal Generator	Agilent	N5182B	My53050553	May 15, 2021	1 Year
Analog Signal Generator	Agilent	N5171B	My53050878	May 15, 2021	1 Year
Signal Analyzer	Agilent	N9010A	My53470879	May 15, 2021	1 Year
Power Analyzer	Agilent	PS-X10-200	N/A	May 15, 2021	1 Year
Wideband Radio Communication Tester	R&S	CMW500	1201.0002K50-140822zk	May 15, 2021	1 Year
Test Accessories	Agilent	PS-X10-100	N/A	May 15, 2021	1 Year
Temperature&Humidity test chamber	ESPEC	EL-02KA	12107166	July 03, 2021	1 Year
Blocking Box	Agilent	AD211	N/A	May 15, 2021	1 Year

Remark: Each piece of equipment is scheduled for calibration once a year.

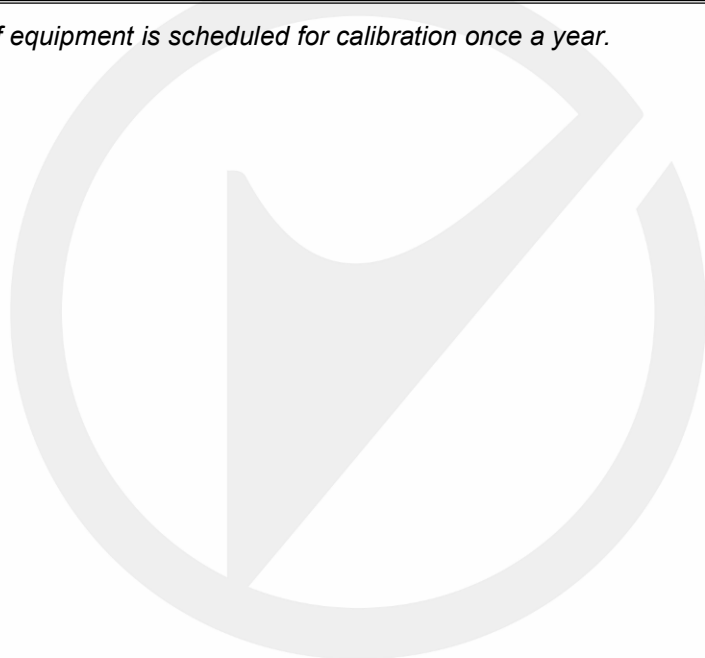

4.3 DESCRIPTION OF TEST MODES

The EUT has been tested under its typical operating condition.

The EUT configuration for testing is installed on RF field strength measurement to meet the Commissions requirement and operating in a manner which intends to maximize its emission characteristics in a continuous normal application.

The Transmitter was operated in the normal operating mode. The TX frequency was fixed which was for the purpose of the measurements.

Test of channel included the lowest and middle and highest frequency to perform the test, then record on this report.

Those data rates (802.11b: 1 Mbps; 802.11g: 6 Mbps; 802.11n (HT20): MCS0; 802.11n (HT40): MCS0) were used for all test.

Pre-defined engineering program for regulatory testing used to control the EUT for staying in continuous transmitting and receiving mode is programmed.

Frequency and Channel list for 802.11 b/g/n (HT20):

Channel	Frequency (MHz)	Channel	Frequency (MHz)	Channel	Frequency (MHz)
1	2412	5	2432	9	2452
2	2417	6	2437	10	2457
3	2422	7	2442	11	2462
4	2427	8	2447		

Frequency and Channel list for 802.11n(HT40):

Channel	Frequency (MHz)	Channel	Frequency (MHz)	Channel	Frequency (MHz)
3	2422	6	2437	9	2452
4	2427	7	2442		
5	2432	8	2447		

Test Frequency and Channel for 802.11 b/g/n (HT20):

Lowest Frequency		Middle Frequency		Highest Frequency	
Channel	Frequency (MHz)	Channel	Frequency (MHz)	Channel	Frequency (MHz)
1	2412	6	2437	11	2462

Test Frequency and channel for 802.11n(HT40):

Lowest Frequency		Middle Frequency		Highest Frequency	
Channel	Frequency (MHz)	Channel	Frequency (MHz)	Channel	Frequency (MHz)
3	2422	6	2437	9	2452

The 2.4G WIFI has two antennas and support Multiple Outputs for 802.11n/ac mode for this report; Antenna 1 Gain is 0.8dBi; Antenna 2 Gain is 0.8dBi; For this function is belong to Correlated Categorization equipment

According to KDB 662911, for identical antenna gains,

$$\text{Directional gain} = 10 \log (2) + 0.8\text{dBi} = 3.8 \text{ dBi}$$

5 FACILITIES AND ACCREDITATIONS

5.1 FACILITIES

All measurement facilities used to collect the measurement data are located at:

EMTEK (Shenzhen) Co., Ltd.

Building 69, Majialong Industry Zone District, Nanshan District, Shenzhen, China

The sites are constructed in conformance with the requirements of ANSI C63.7, ANSI C63.4 and CISPR Publication 22.

5.2 EQUIPMENT

Radiated emissions are measured with one or more of the following types of linearly polarized antennas: tuned dipole, biconical, log periodic, bi-log, and/or ridged waveguide, horn. Spectrum analyzers with preselectors and quasi-peak detectors are used to perform radiated measurements.

Conducted emissions are measured with Line Impedance Stabilization Networks and EMI Test Receivers.

Calibrated wideband preamplifiers, coaxial cables, and coaxial attenuators are also used for making measurements.

All receiving equipment conforms to CISPR Publication 16-1, "Radio Interference Measuring Apparatus and Measurement Methods."

5.3 LABORATORY ACCREDITATIONS AND LISTINGS

Site Description	
EMC Lab.	<p>: Accredited by CNAS The Certificate Registration Number is L2291. The Laboratory has been assessed and proved to be in compliance with CNAS-CL01 (identical to ISO/IEC 17025:2017)</p> <p>Accredited by FCC Designation Number: CN1204 Test Firm Registration Number: 882943</p> <p>Accredited by A2LA The Certificate Number is 4321.01.</p> <p>Accredited by Industry Canada The Conformity Assessment Body Identifier is CN0008</p>
Name of Firm	: EMTEK (SHENZHEN) CO., LTD.
Site Location	: Building 69, Majialong Industry Zone, Nanshan District, Shenzhen, Guangdong, China

6 TEST SYSTEM UNCERTAINTY

The following measurement uncertainty levels have been estimated for tests performed on the apparatus:

Parameter	Uncertainty
Radio Frequency	$\pm 1 \times 10^{-5}$
Maximum Peak Output Power Test	$\pm 1.0\text{dB}$
Conducted Emissions Test	$\pm 2.0\text{dB}$
Radiated Emission Test	$\pm 2.0\text{dB}$
Power Density	$\pm 2.0\text{dB}$
Occupied Bandwidth Test	$\pm 1.0\text{dB}$
Band Edge Test	$\pm 3\text{dB}$
All emission, radiated	$\pm 3\text{dB}$
Antenna Port Emission	$\pm 3\text{dB}$
Temperature	$\pm 0.5^\circ\text{C}$
Humidity	$\pm 3\%$

Measurement Uncertainty for a level of Confidence of 95%



7 SETUP OF EQUIPMENT UNDER TEST

7.1 RADIO FREQUENCY TEST SETUP 1

The WLAN component's antenna ports(s) of the EUT are connected to the measurement instrument per an appropriate attenuator. The EUT is controlled by PC/software to emit the specified signals for the purpose of measurements.



7.2 RADIO FREQUENCY TEST SETUP 2

The test site semi-anechoic chamber has met the requirement of NSA tolerance 4 dB according to the standards: ANSI C63.10. The test distance is 3m. The setup is according to the requirements in Section 13.1.4.1 of ANSI C63.10-2013 and CAN/CSA-CEI/IEC CISPR 22.

30MHz-1GHz:

The EUT is placed on a plane 0.1 meters above the ground in the chamber, 3 meter away from the antenna. The maximal emission value is acquired by adjusting the antenna height, polarisation and turntable azimuth. Normally, the height range of antenna is 1 m to 4 m, the azimuth range of turntable is 0° to 360°, and the receive antenna has two polarizations Vertical (V) and Horizontal (H).

Above 1GHz:

The EUT is placed on plane 0.1 meters above the ground in the chamber, 3 meter away from the antenna. The maximal emission value is acquired by adjusting the antenna height, polarisation and turntable azimuth. Normally, the height range of antenna is 1 m to 4 m, the azimuth range of turntable is 0° to 360°, and the receive antenna has two polarizations Vertical (V) and Horizontal (H).

(a) Radiated Emission Test Set-Up, Frequency Below 1000MHz

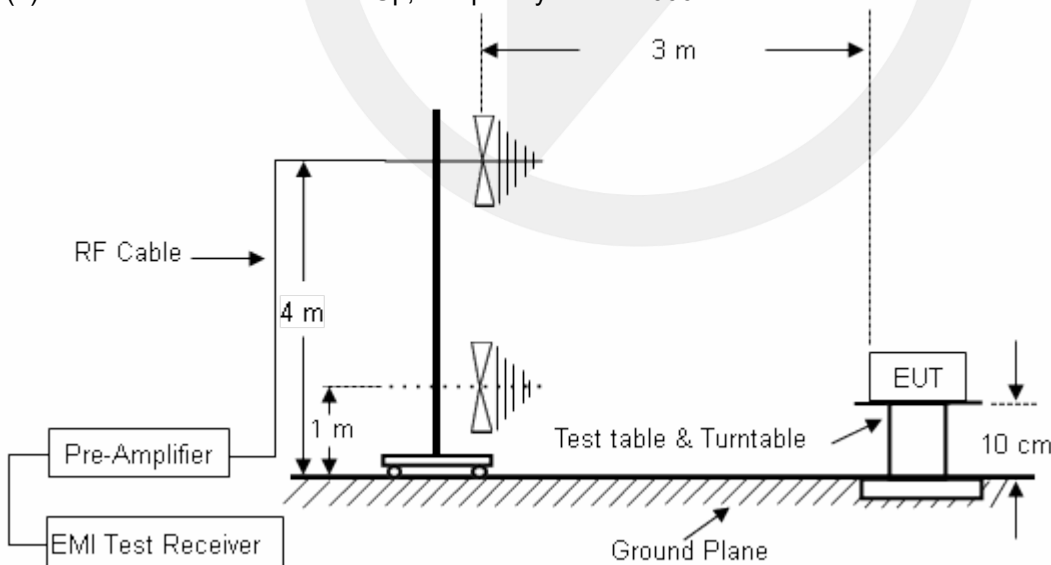

(b) Radiated Emission Test Set-Up, Frequency above 1000MHz

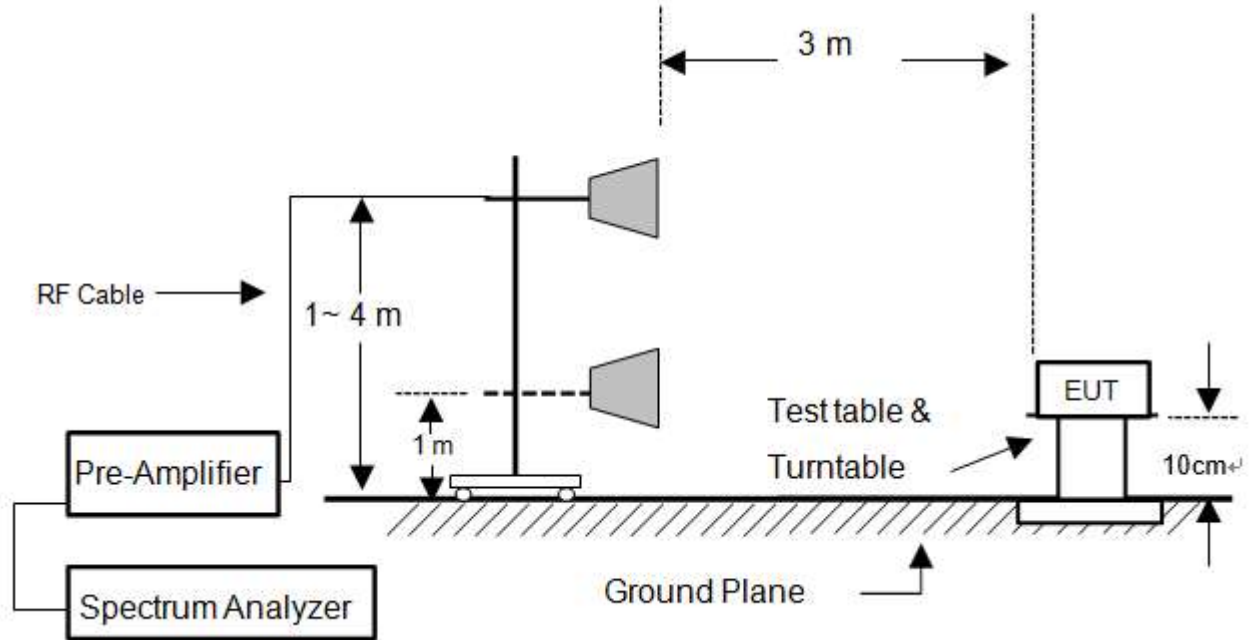

7.3 CONDUCTED EMISSION TEST SETUP

The mains cable of the EUT (maybe per AC/DC Adapter) must be connected to LISN. The LISN shall be placed 0.8 m from the boundary of EUT and bonded to a ground reference plane for LISN mounted on top of the ground reference plane. This distance is between the closest points of the LISN and the EUT. All other units of the EUT and associated equipment shall be at least 0.8m from the LISN. Ground connections, where required for safety purposes, shall be connected to the reference ground point of the LISN and, where not otherwise provided or specified by the manufacturer, shall be of same length as the mains cable and run parallel to the mains connection at a separation distance of not more than 0.1 m.

According to the requirements in Section 13.1.4.1 of ANSI C63.10-2013 Conducted emissions from the EUT measured in the frequency range between 0.15 MHz and 30 MHz using CISPR Quasi-Peak and average detector mode.

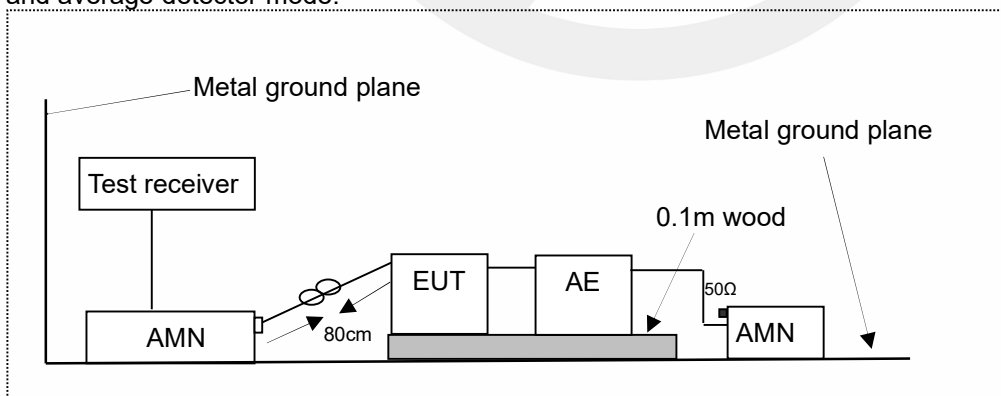

7.4 BLOCK DIAGRAM CONFIGURATION OF TEST SYSTEM

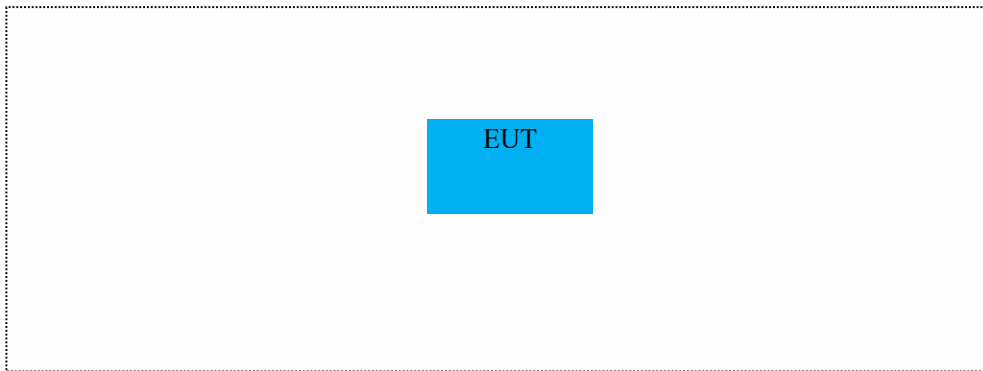

7.5 SUPPORT EQUIPMENT

Item	Equipment	Mfr/Brand	Model/Type No.	FCC ID	Series No.	Note
N/A	N/A	N/A	N/A	N/A	N/A	N/A

Notes:

1. All the equipment/cables were placed in the worst-case configuration to maximize the emission during the test.
2. Grounding was established in accordance with the manufacturer's requirements and conditions for the intended use.

8 TEST REQUIREMENTS

8.1 DTS(6DB)BANDWIDTH

8.1.1 Applicable Standard

According to FCC Part15.247 (a)(2) and KDB 558074 D01 15.247 Meas Guidance v05r02

8.1.2 Conformance Limit

The minimum -6 dB bandwidth shall be at least 500 kHz.

8.1.3 Test Configuration

Test according to clause 7.1 radio frequency test setup 1

8.1.4 Test Procedure

The EUT was operating in IEEE 802.11b/g/n mode and controlled its channel. Printed out the test result from the spectrum by hard copy function.

The RF output of EUT was connected to the spectrum analyzer by RF cable and attenuator. The path loss was compensated to the results for each measurement.

Set to the maximum power setting and enable the EUT transmit continuously

Set RBW = 100 kHz.

Set the video bandwidth (VBW) =300kHz.

Set Span=2 times OBW

Set Detector = Peak.

Set Trace mode = max hold.

Set Sweep = auto couple.

Allow the trace to stabilize.

Measure the maximum width of the emission that is constrained by the frequencies associated with the two outermost amplitude points (upper and lower frequencies) that are attenuated by 6 dB relative to the maximum level measured in the fundamental emission.

Measure and record the results in the test report.

8.1.5 Test Results

Temperature:	25° C
Relative Humidity:	45%
ATM Pressure:	1011 mbar

TestMode	Antenna	Frequency[MHz]	DTS BW [MHz]	FL[MHz]	FH[MHz]	Limit[MHz]	Verdict
11B	Ant1	2412	6.600	2408.440	2415.040	0.5	PASS
	Ant2	2412	7.080	2408.440	2415.520	0.5	PASS
	Ant1	2437	7.080	2433.440	2440.520	0.5	PASS
	Ant2	2437	6.600	2433.920	2440.520	0.5	PASS
	Ant1	2462	7.080	2458.440	2465.520	0.5	PASS
	Ant2	2462	8.040	2457.960	2466.000	0.5	PASS
11G	Ant1	2412	16.320	2403.800	2420.120	0.5	PASS
	Ant2	2412	16.320	2403.800	2420.120	0.5	PASS
	Ant1	2437	16.320	2428.800	2445.120	0.5	PASS
	Ant2	2437	16.440	2428.800	2445.240	0.5	PASS
	Ant1	2462	16.280	2453.840	2470.120	0.5	PASS
	Ant2	2462	16.360	2453.800	2470.160	0.5	PASS
11N20SISO	Ant1	2412	17.320	2403.440	2420.760	0.5	PASS
	Ant2	2412	17.160	2403.600	2420.760	0.5	PASS
	Ant1	2437	17.560	2428.200	2445.760	0.5	PASS
	Ant2	2437	17.560	2428.200	2445.760	0.5	PASS
	Ant1	2462	17.560	2453.200	2470.760	0.5	PASS
	Ant2	2462	17.560	2453.200	2470.760	0.5	PASS
11N40SISO	Ant1	2422	36.320	2403.840	2440.160	0.5	PASS
	Ant2	2422	36.320	2403.840	2440.160	0.5	PASS
	Ant1	2437	36.320	2418.840	2455.160	0.5	PASS
	Ant2	2437	36.320	2418.840	2455.160	0.5	PASS
	Ant1	2452	36.320	2433.840	2470.160	0.5	PASS
	Ant2	2452	36.320	2433.840	2470.160	0.5	PASS



11B_Ant1_2412



11B_Ant2_2412





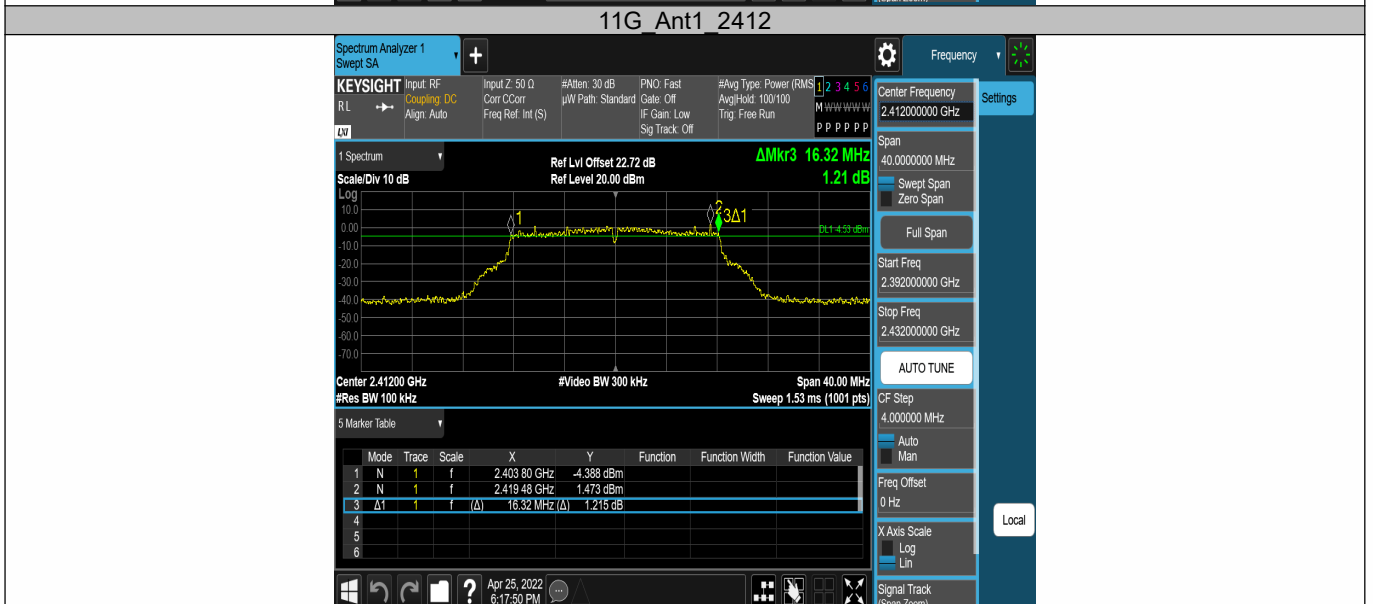
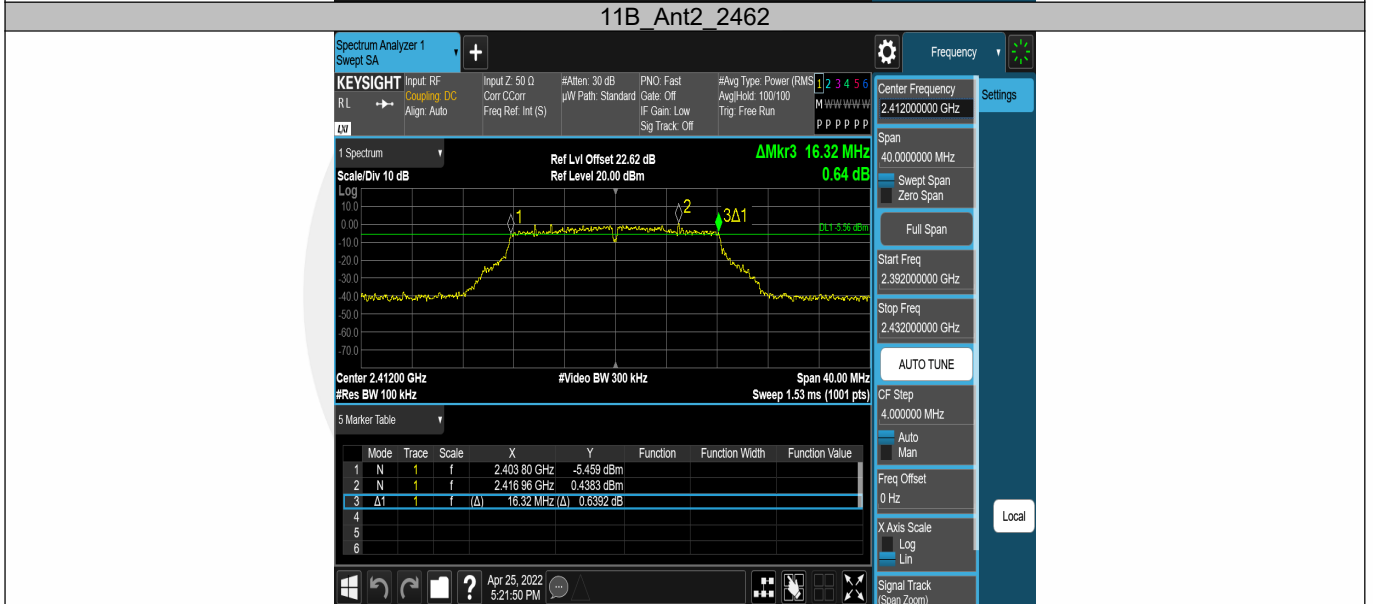

11G_Ant2_2412

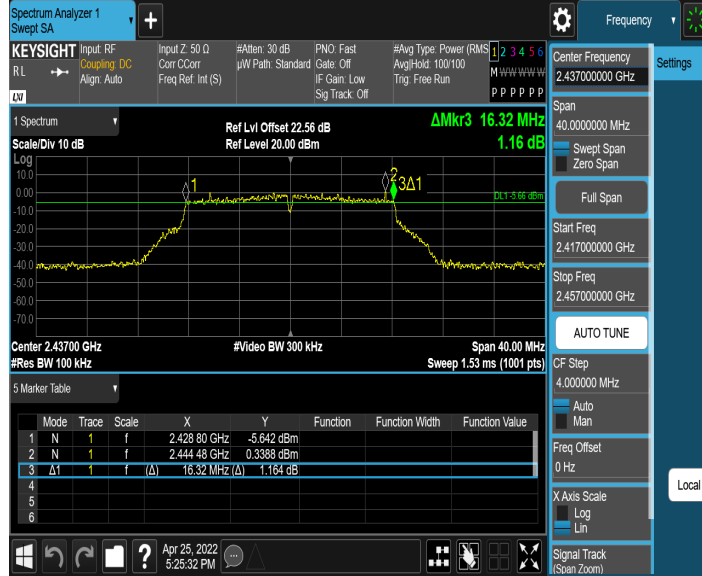

11G_Ant1_2437

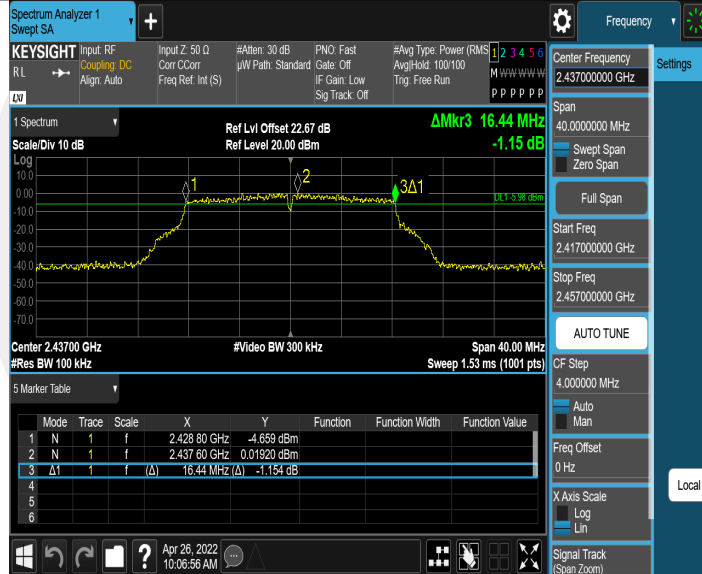

11G_Ant2_2437

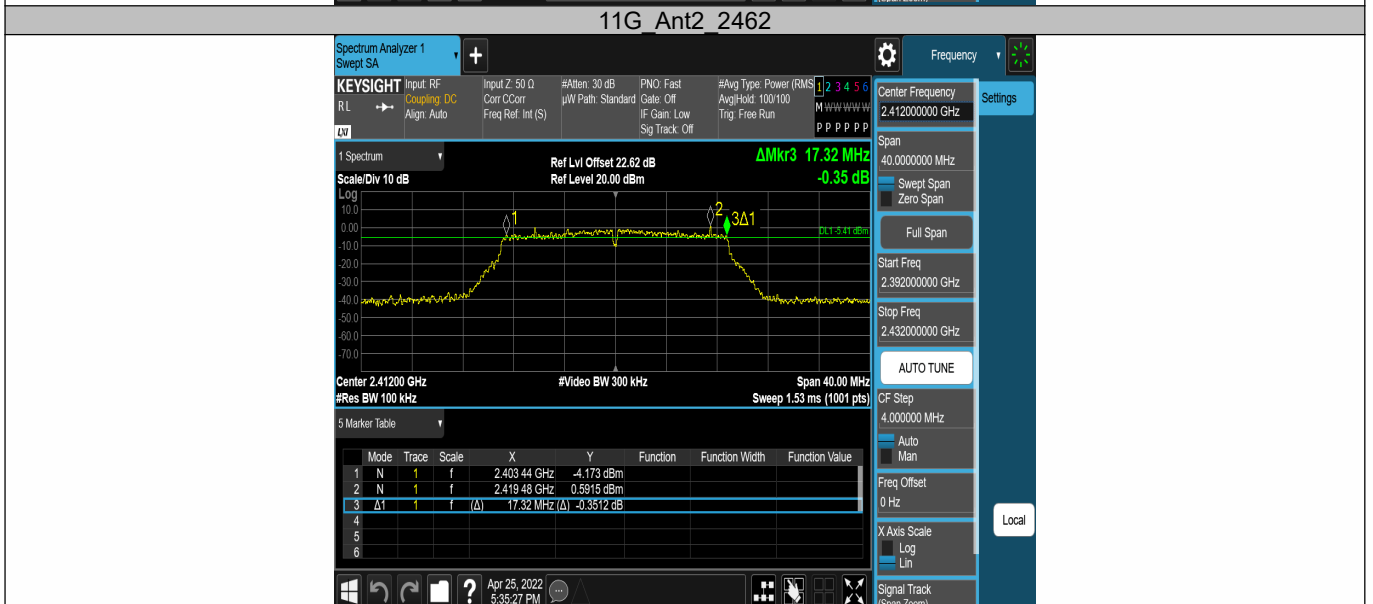
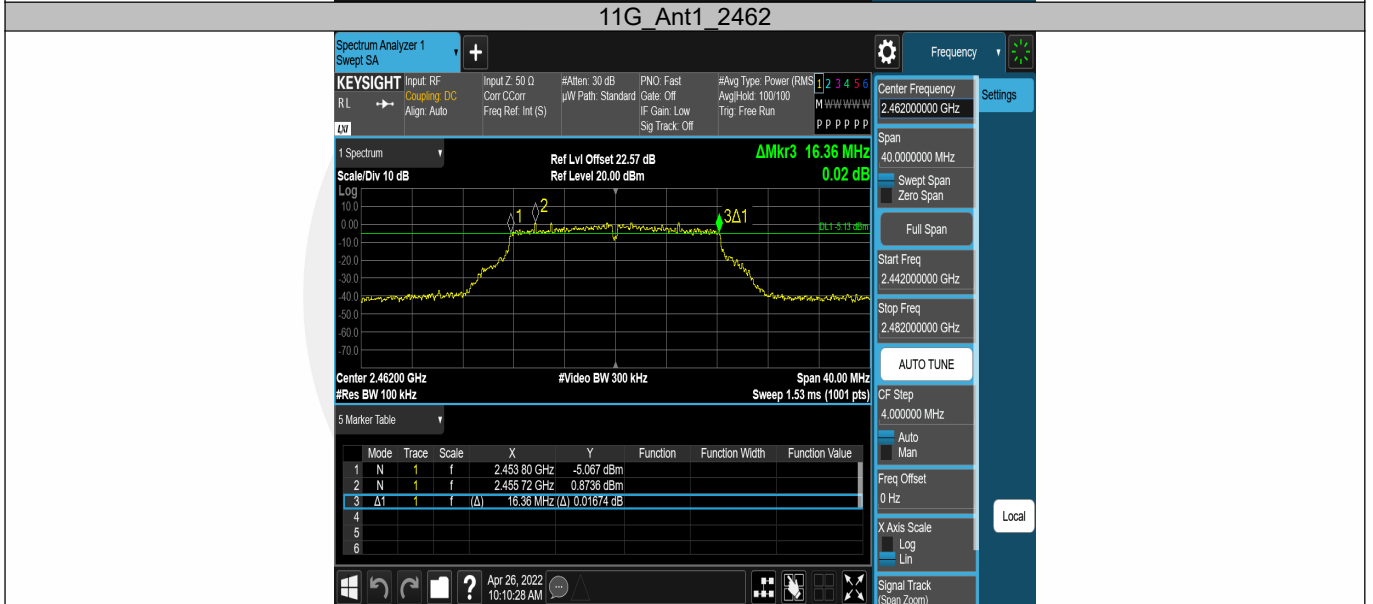

11N20SISO_Ant1_2412



11N20SISO_Ant2_2412

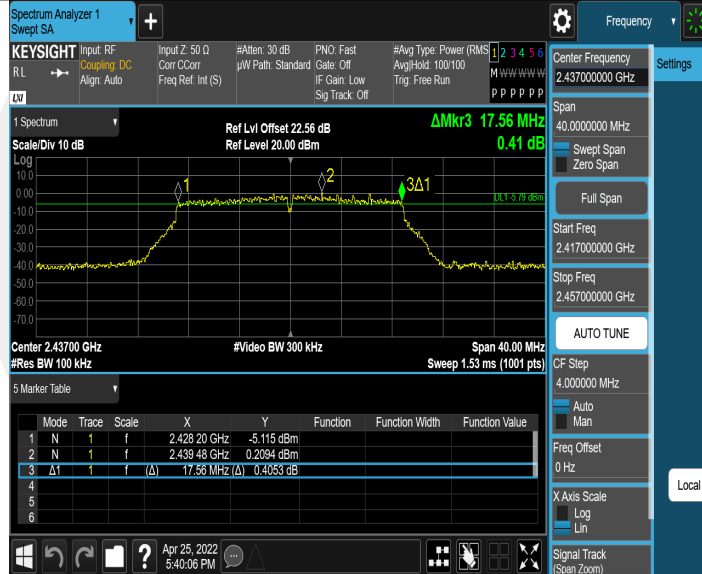

11N20SISO_Ant1_2437

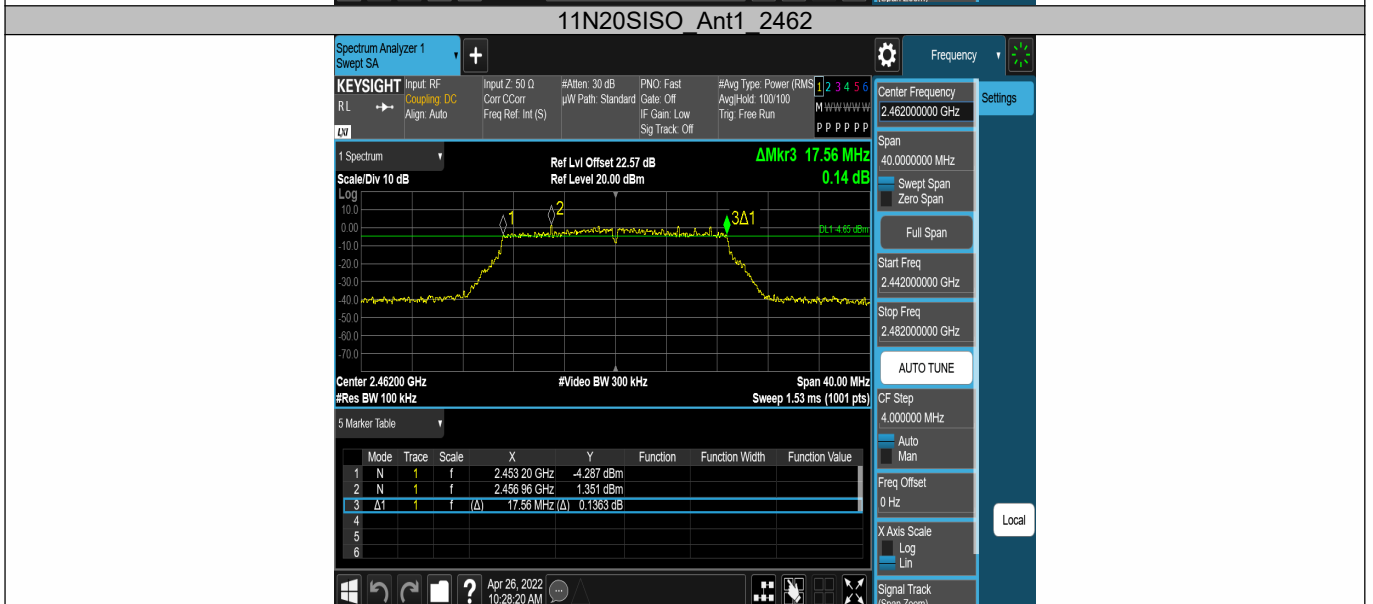
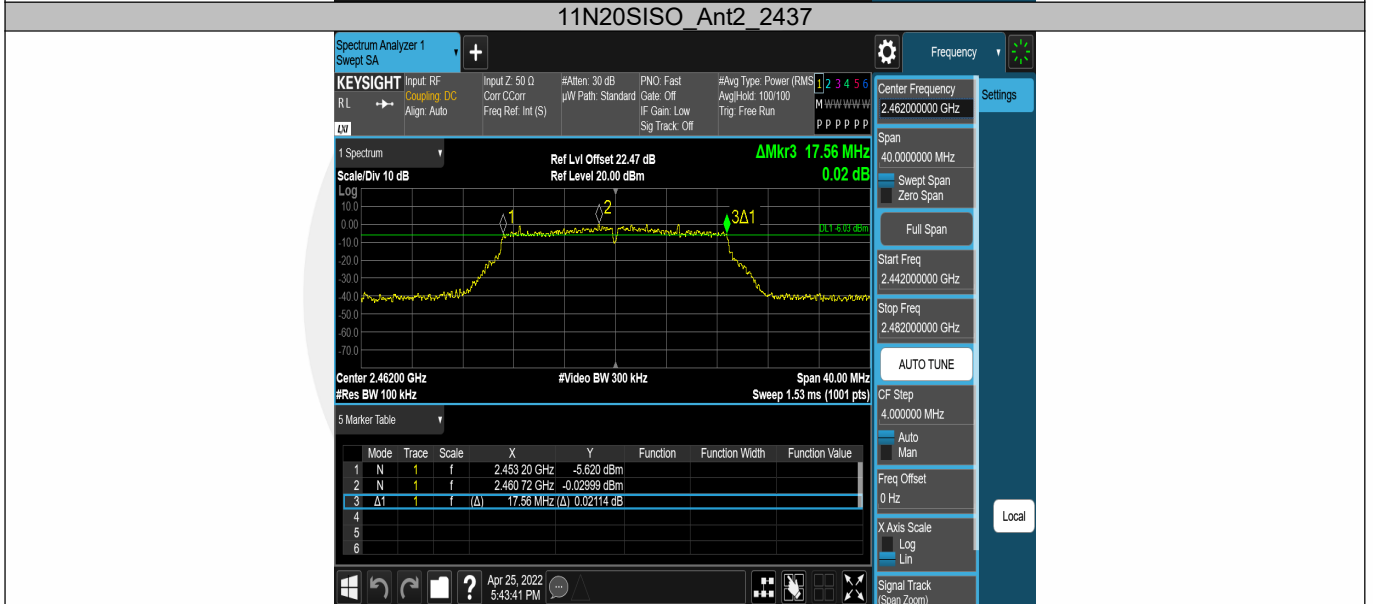

11N20SISO_Ant2_2462

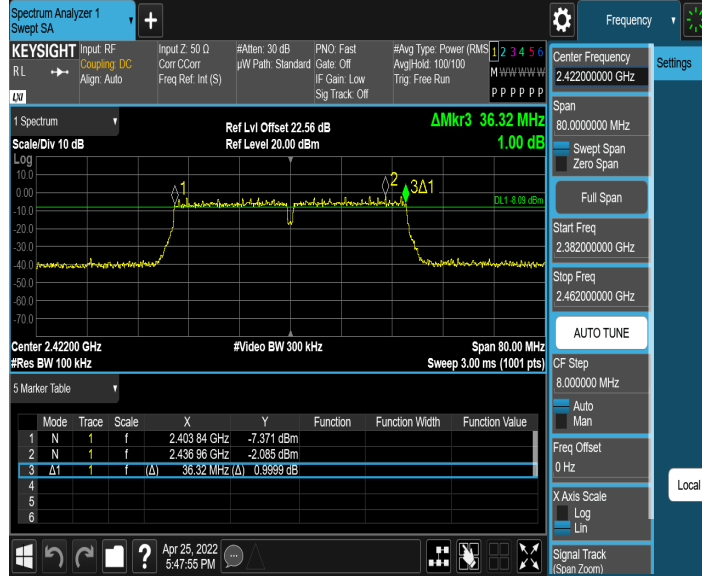

11N40SISO_Ant1_2422

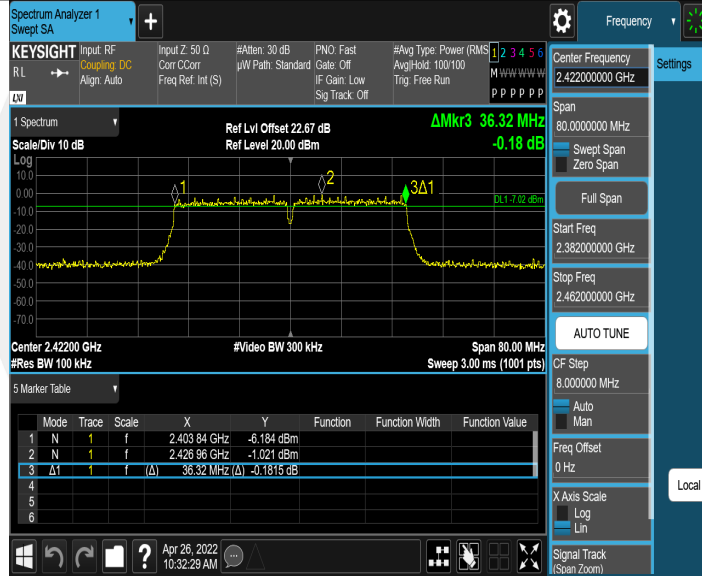

11N40SISO_Ant2_2422

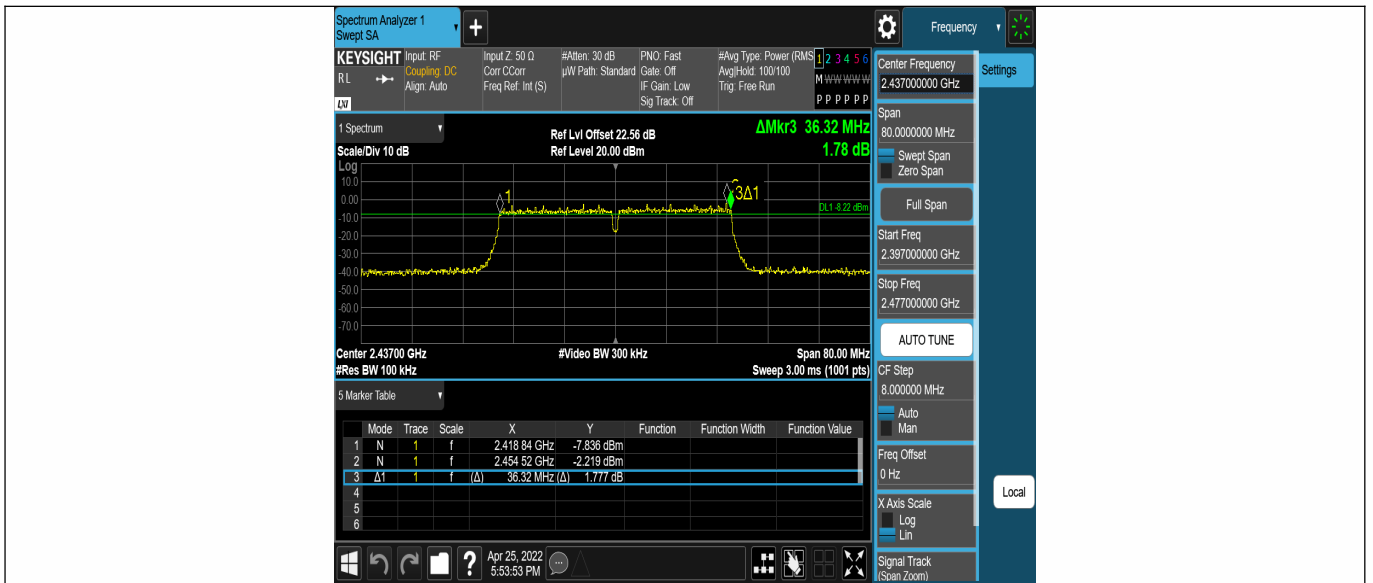

11N40SISO Ant1 2437



11N40SISO Ant2 2437

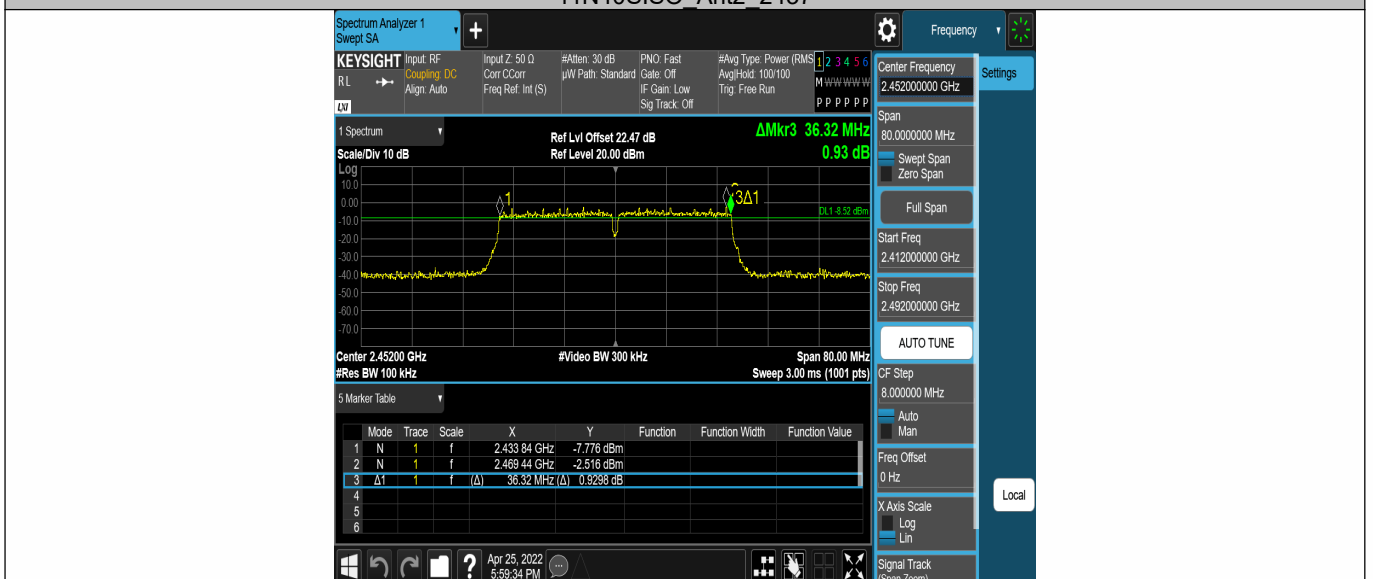

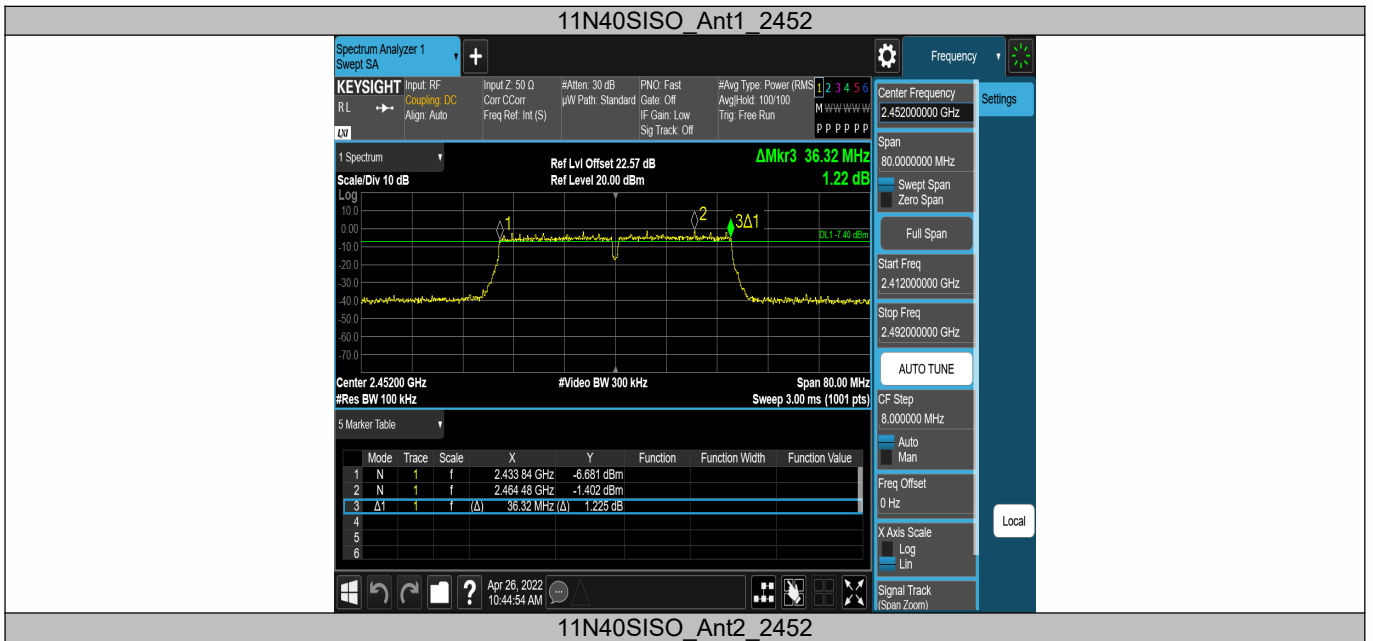

8.2 MAXIMUM PEAK CONDUCTED OUTPUT POWER

8.2.1 Applicable Standard

According to FCC Part15.247 (b)(3) and KDB 558074 D01 15.247 Meas Guidance v05r02

8.2.2 Conformance Limit

The maximum peak conducted output power of the intentional radiator for systems using digital modulation in the 2400 - 2483.5 MHz bands shall not exceed: 1 Watt (30dBm).

8.2.3 Test Configuration

Test according to clause 7.1 radio frequency test setup 1

8.2.4 Test Procedure

■ According to FCC Part15.247(b)(3)

The maximum peak conducted output power may be measured using a broadband peak RF power meter. The power meter shall have a video bandwidth that is greater than or equal to the DTS bandwidth and shall utilize a fast-responding diode detector.

The testing follows FCC public Notice DA 00-705 Measurement Guidelines.

The RF output of EUT was connected to the power meter by RF cable and attenuator. The path loss was compensated to the results for each measurement.

Set to the maximum output power setting and enable the EUT transmit continuously.

Measure the conducted output power with cable loss and record the results in the test report.

Measure and record the results in the report.

■ According to FCC Part 15.247(b)(4):

Conducted output power limit specified in paragraph (b) of this section is based on the use of antennas with directional gains that do not exceed 6 dBi. If transmitting antennas of directional gain greater than 6 dBi are used, the conducted output power from the intentional radiator shall be reduced below the stated values in paragraphs (b)(3) of this section, as appropriate, by the amount in dB that the directional gain of the antenna exceeds 6 dBi. Note: If antenna Gain exceeds 6 dBi, then Output power Limit=30-(Gain- 6)

8.2.5 Test Results

Temperature:	25° C
Relative Humidity:	45%
ATM Pressure:	1011 mbar

TestMode	Antenna	Frequency[MHz]	Power[dBm]	Conducted Limit[dBm]	EIRP [dBm]	EIRP Limit[dBm]	Verdict
11B	Ant1	2412	13.29	≤30.00	14.09	≤36.00	PASS
	Ant2	2412	14.30	≤30.00	15.1	≤36.00	PASS
	Ant1	2437	13.24	≤30.00	14.04	≤36.00	PASS
	Ant2	2437	14.32	≤30.00	15.12	≤36.00	PASS
	Ant1	2462	13.13	≤30.00	13.93	≤36.00	PASS
	Ant2	2462	14.23	≤30.00	15.03	≤36.00	PASS
11G	Ant1	2412	12.78	≤30.00	13.58	≤36.00	PASS
	Ant2	2412	13.76	≤30.00	14.56	≤36.00	PASS
	Ant1	2437	12.57	≤30.00	13.37	≤36.00	PASS
	Ant2	2437	13.38	≤30.00	14.18	≤36.00	PASS
	Ant1	2462	12.44	≤30.00	13.24	≤36.00	PASS
	Ant2	2462	13.25	≤30.00	14.05	≤36.00	PASS
11N20SIS O	Ant1	2412	12.76	≤30.00	13.56	≤36.00	PASS
	Ant2	2412	13.89	≤30.00	14.69	≤36.00	PASS
	Ant1	2437	12.47	≤30.00	13.27	≤36.00	PASS
	Ant2	2437	13.74	≤30.00	14.54	≤36.00	PASS
	Ant1	2462	12.37	≤30.00	13.17	≤36.00	PASS
	Ant2	2462	13.56	≤30.00	14.36	≤36.00	PASS
11N40SIS O	Ant1	2422	13.04	≤30.00	13.84	≤36.00	PASS
	Ant2	2422	14.03	≤30.00	14.83	≤36.00	PASS
	Ant1	2437	13.06	≤30.00	13.86	≤36.00	PASS
	Ant2	2437	14.03	≤30.00	14.83	≤36.00	PASS
	Ant1	2452	12.88	≤30.00	13.68	≤36.00	PASS
	Ant2	2452	13.94	≤30.00	14.74	≤36.00	PASS
11N20MIMO		2412	16.37	≤30.00	17.17	≤36.00	PASS
		2437	16.16	≤30.00	16.96	≤36.00	PASS
		2462	16.02	≤30.00	16.82	≤36.00	PASS
11N40MIMO		2422	16.57	≤30.00	17.37	≤36.00	PASS
		2437	16.58	≤30.00	17.38	≤36.00	PASS
		2452	16.45	≤30.00	17.25	≤36.00	PASS

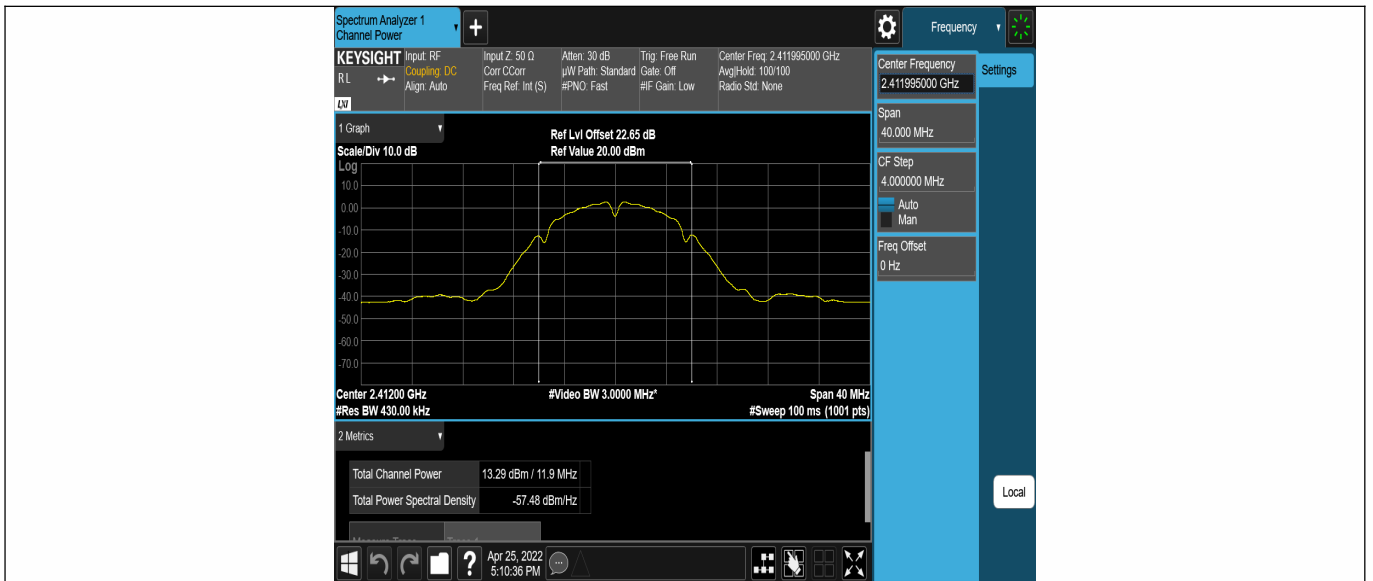

11B_Ant1_2412

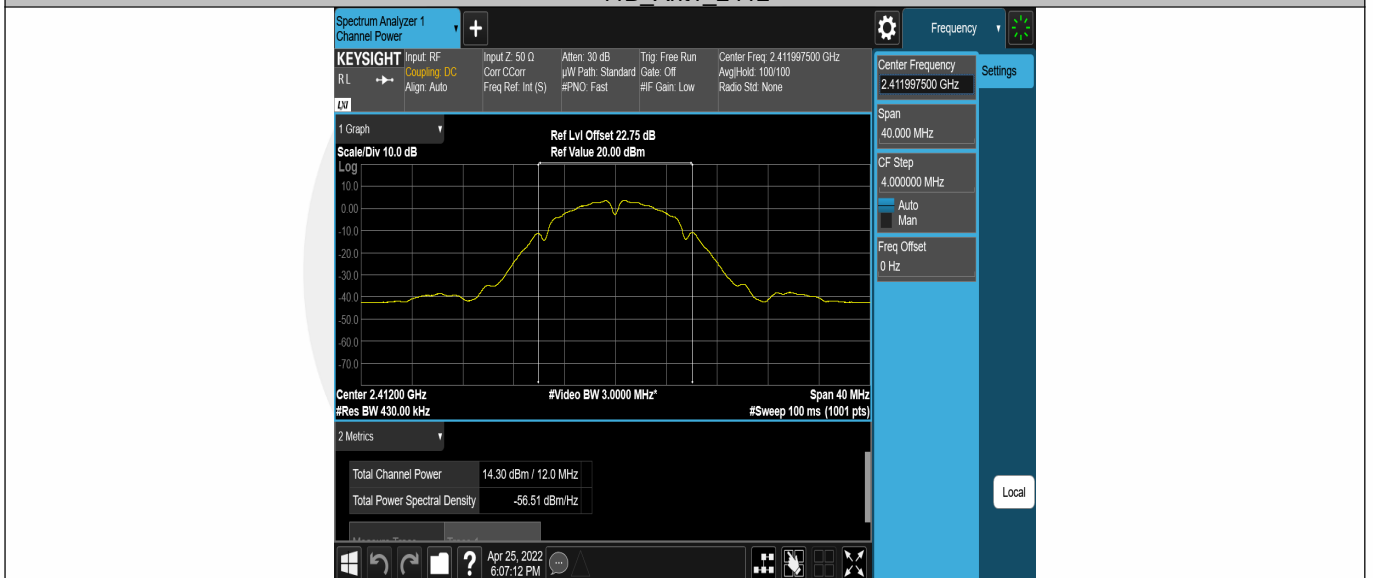

11B_Ant2_2412

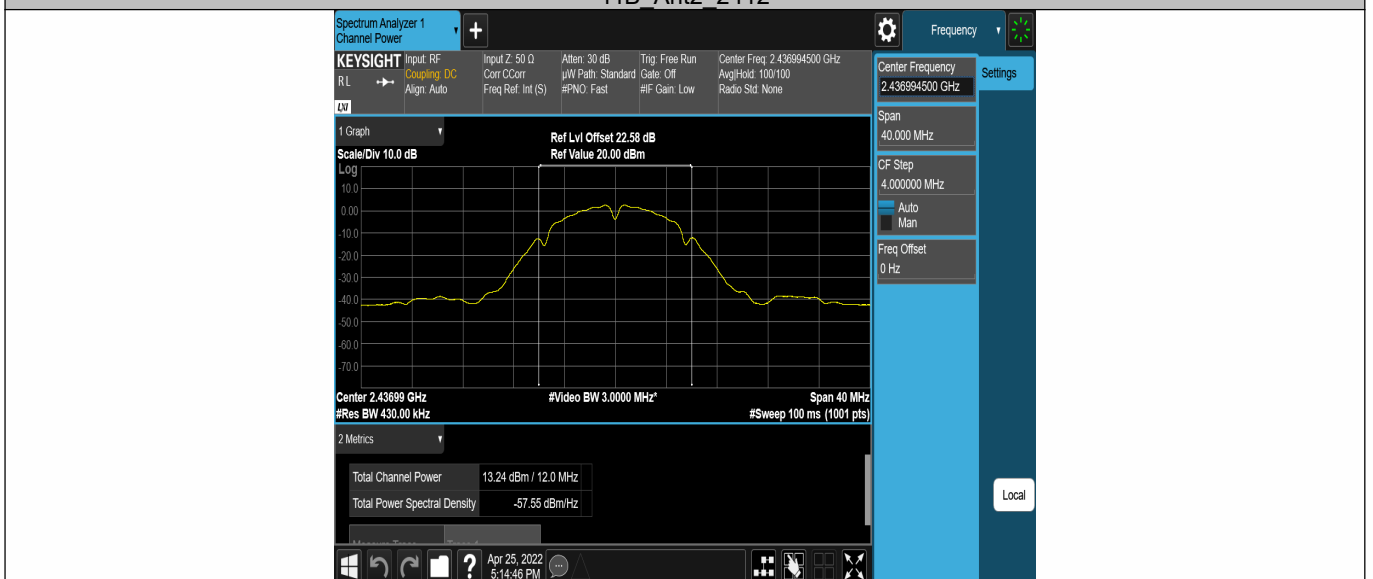

11B_Ant1_2437

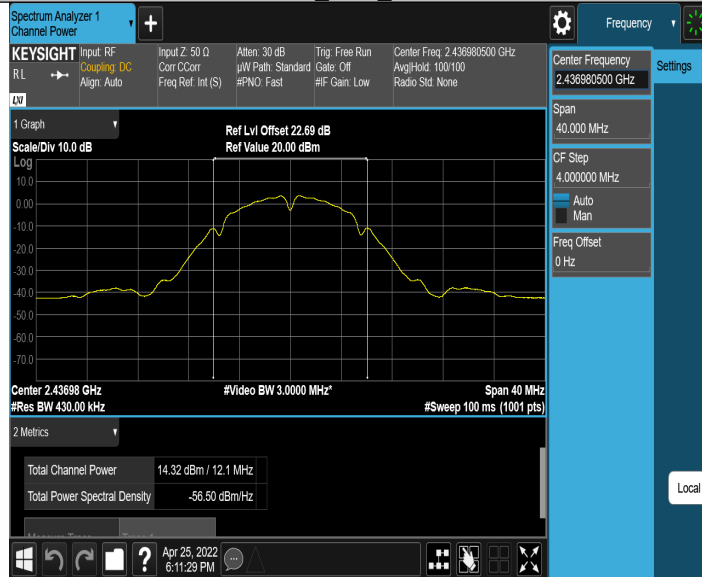

11B_Ant2_2437

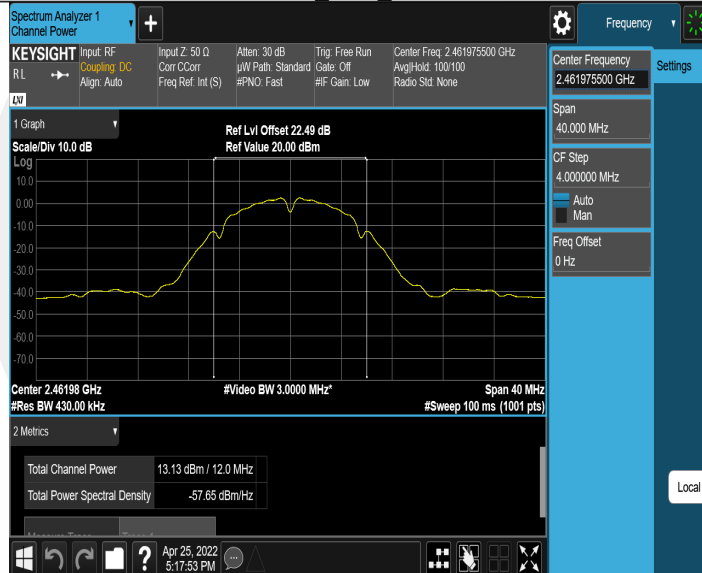

11B_Ant1_2462

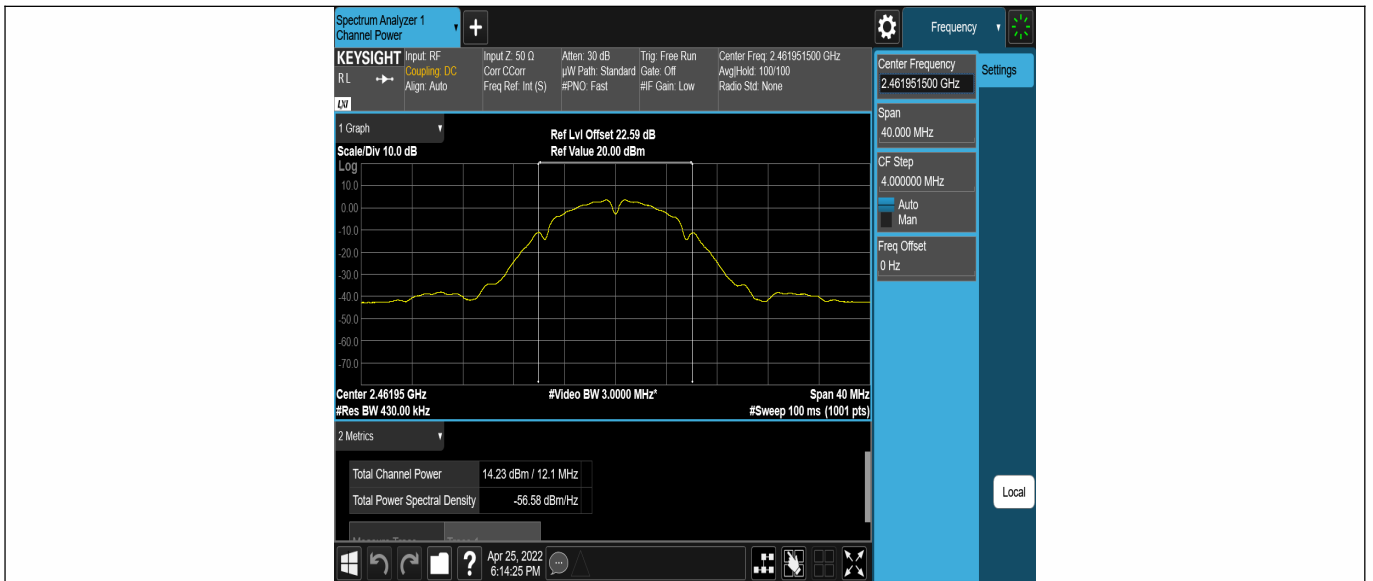

11B_Ant2_2462

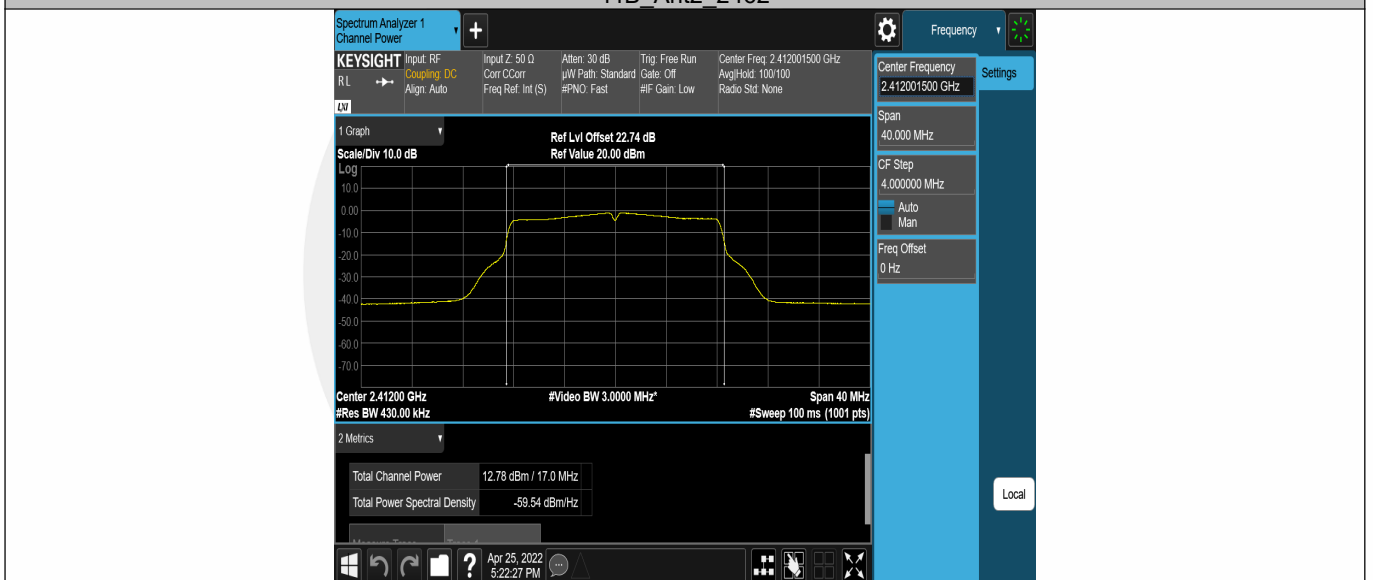

11G_Ant1_2412

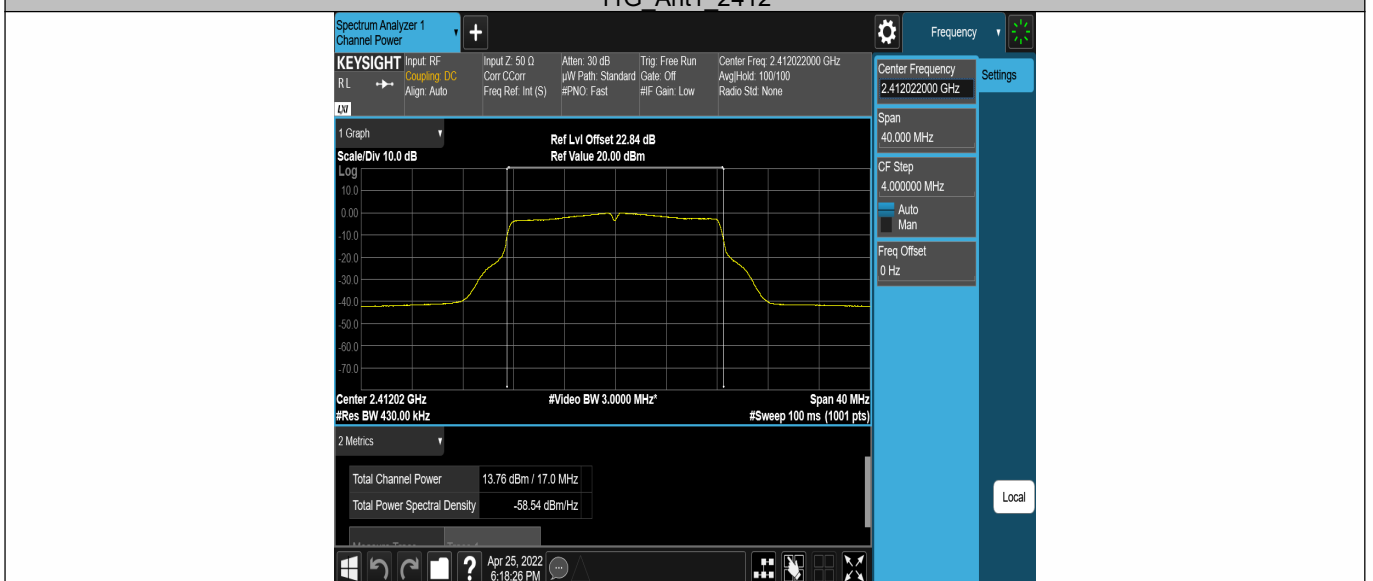

11G_Ant2_2412

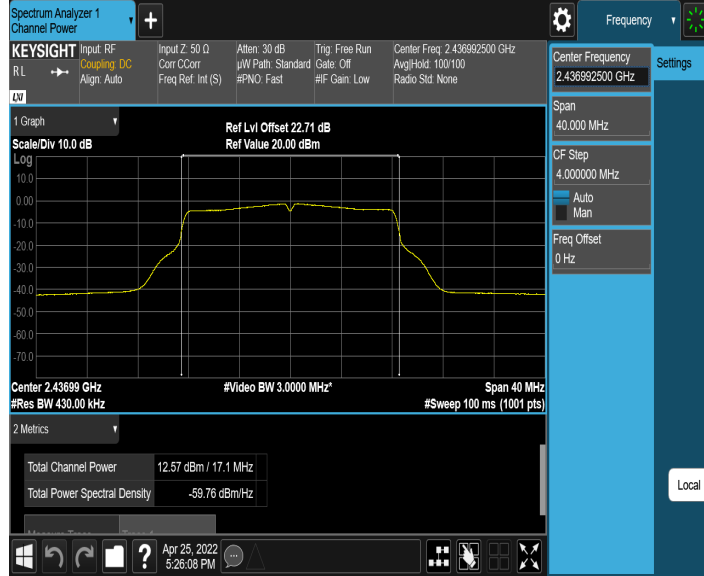

11G_Ant1_2437

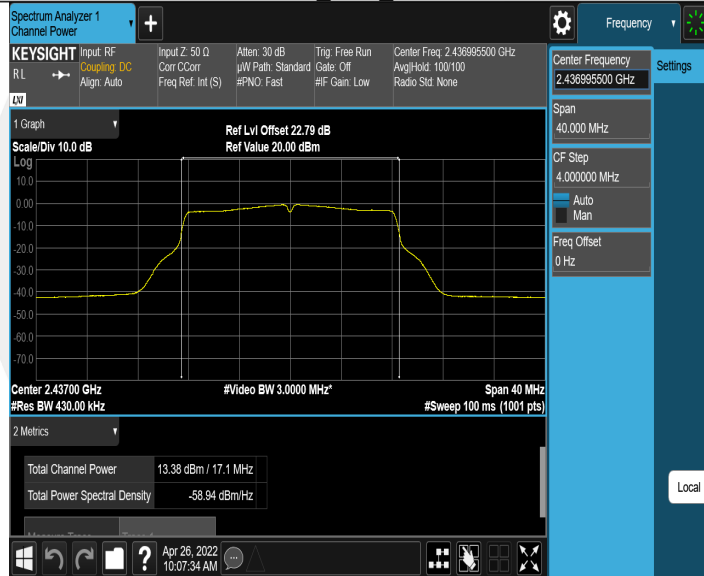

11G_Ant2_2437

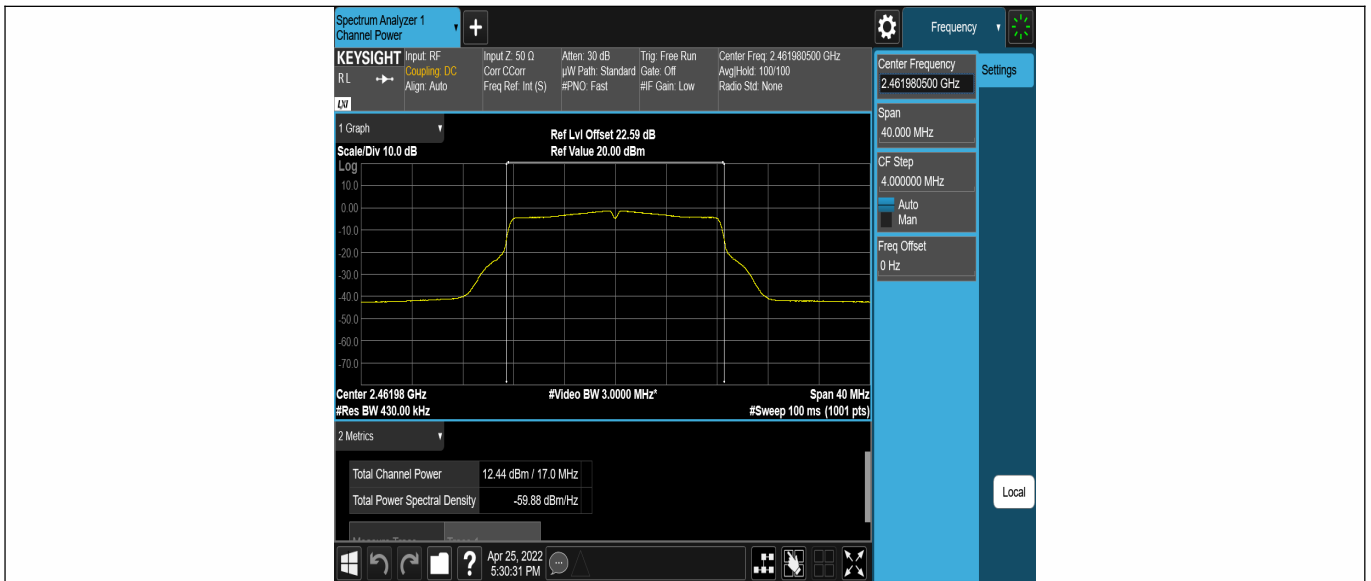

11G_Ant1_2462

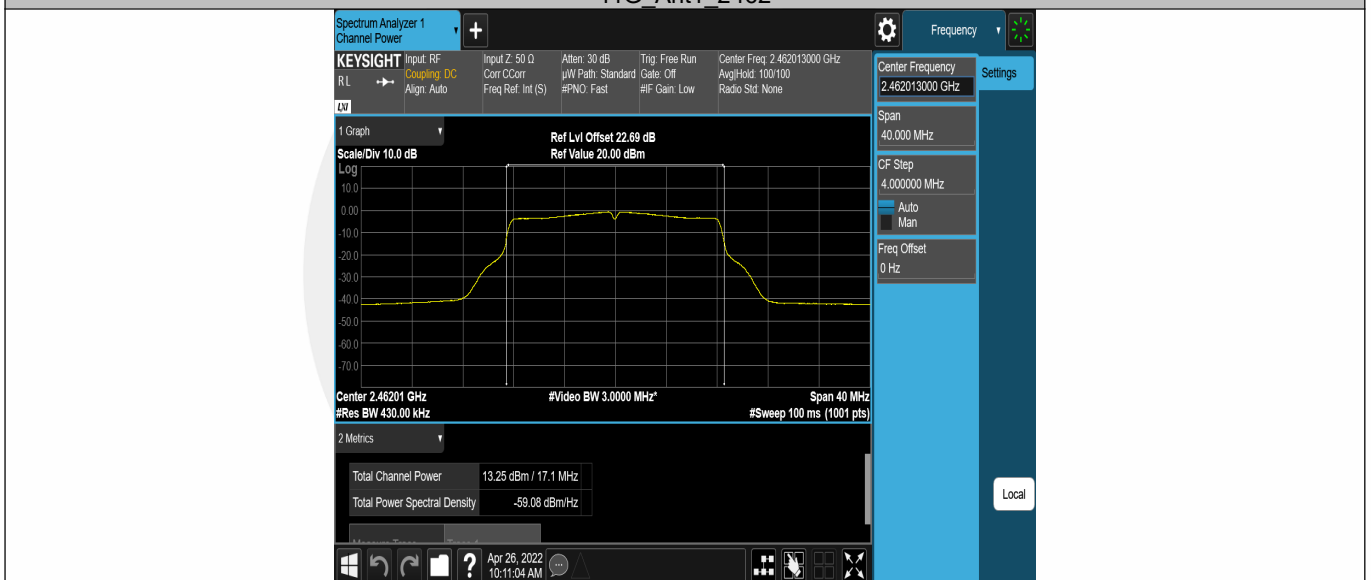

11G_Ant2_2462

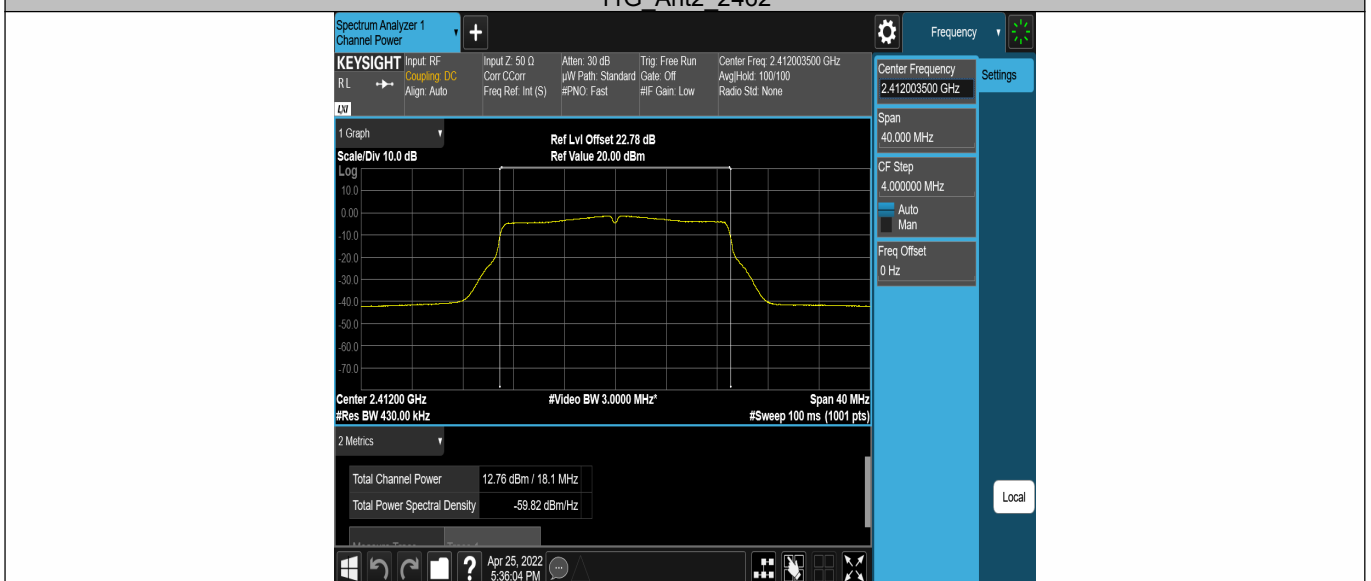

11N20SISO_Ant1_2412

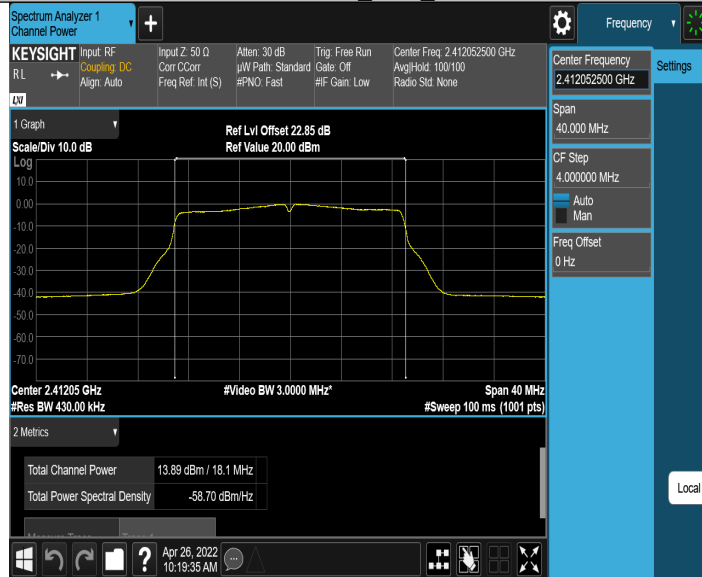

11N20SISO_Ant2_2412



11N20SISO_Ant1_2437

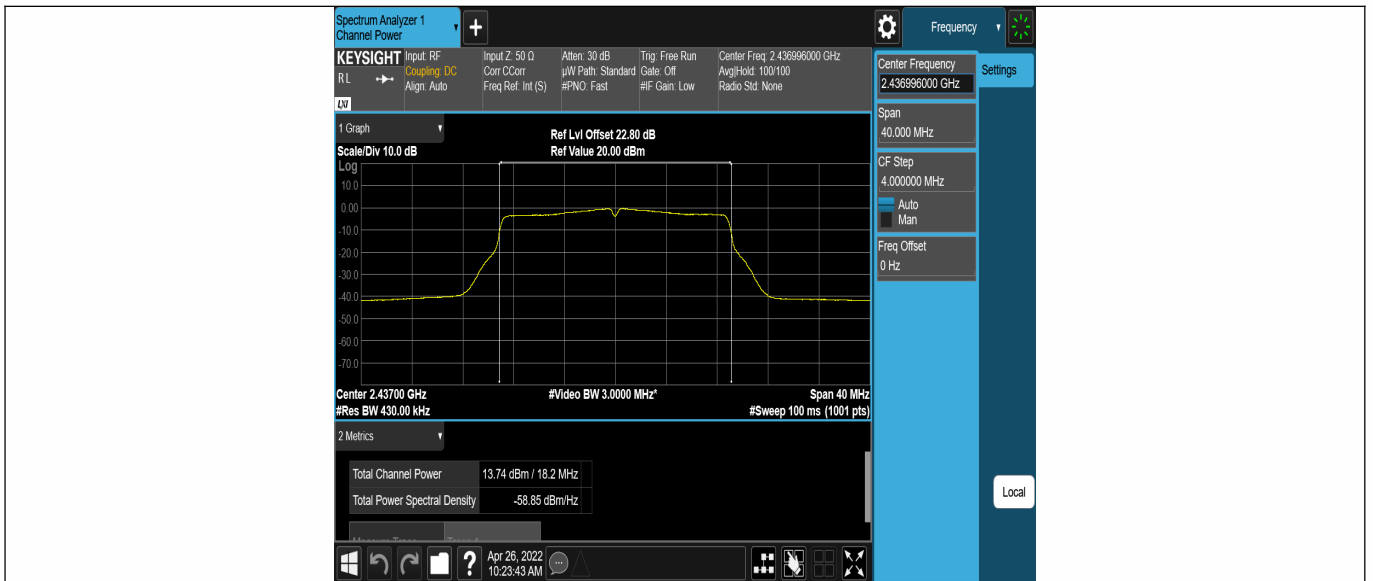

11N20SISO_Ant2_2437

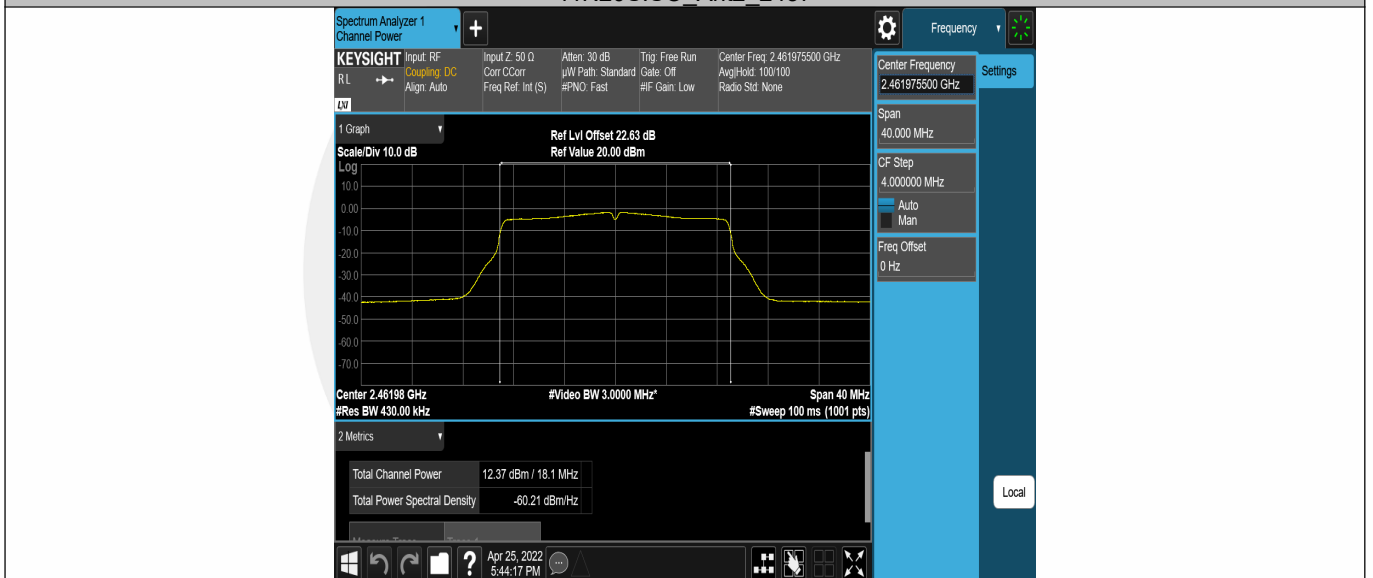

11N20SISO_Ant1_2462

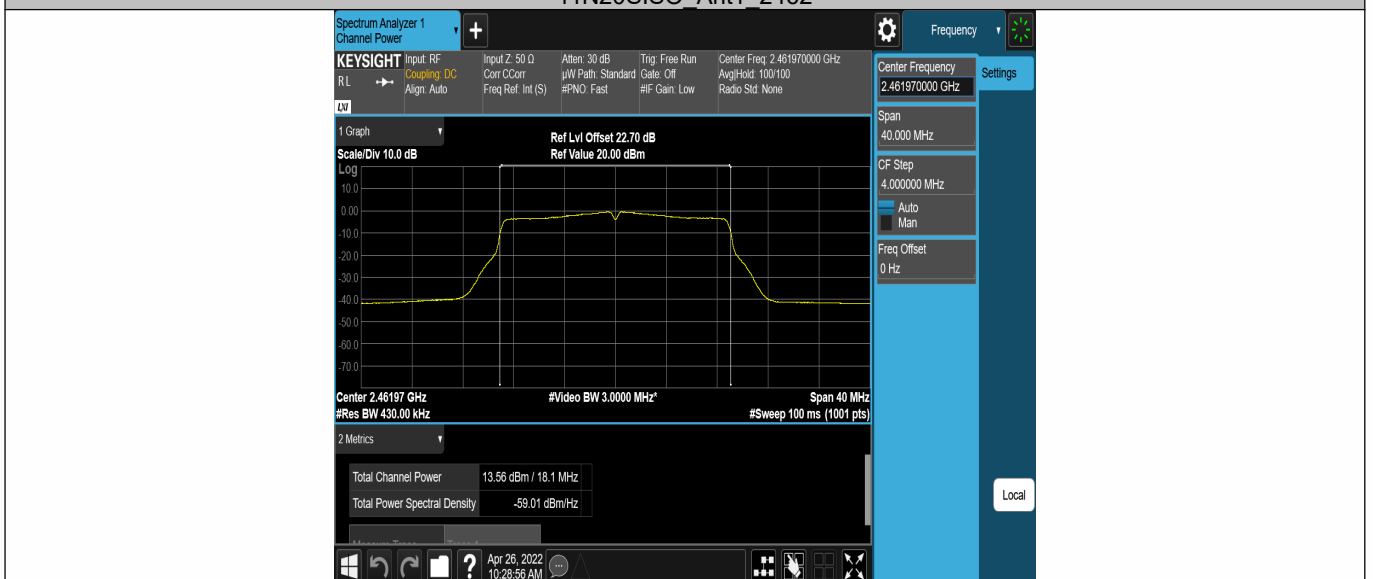

11N20SISO_Ant2_2462

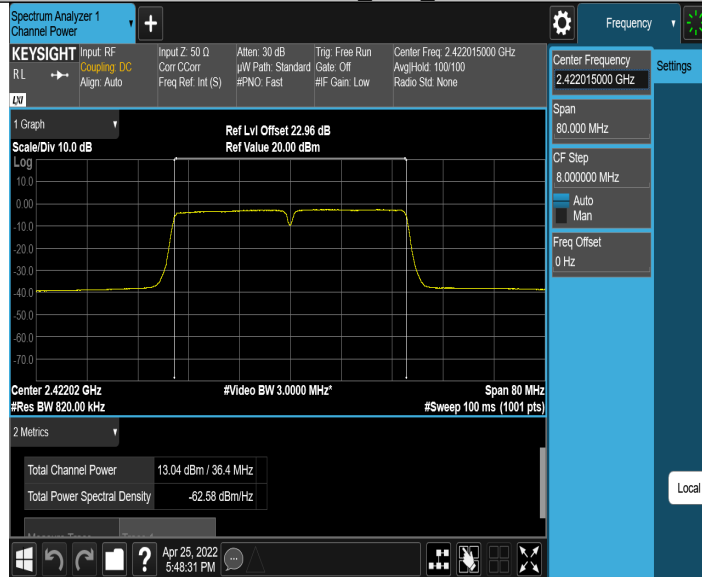

11N40SISO_Ant1_2422

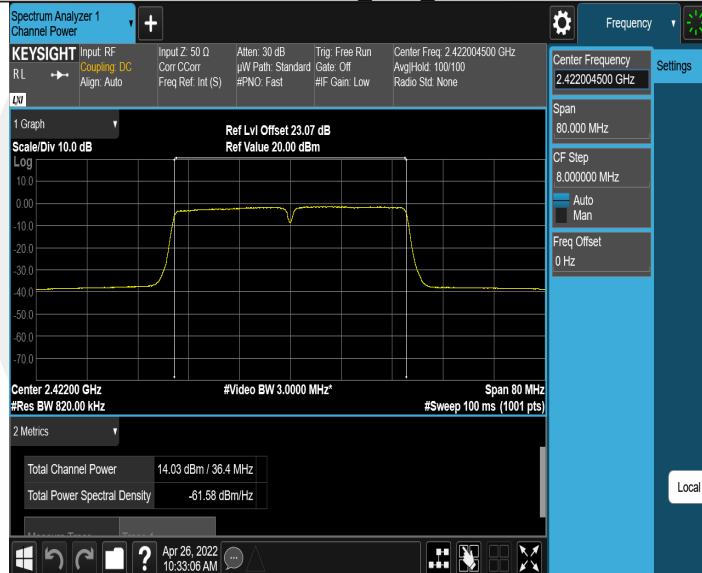

11N40SISO_Ant2_2422

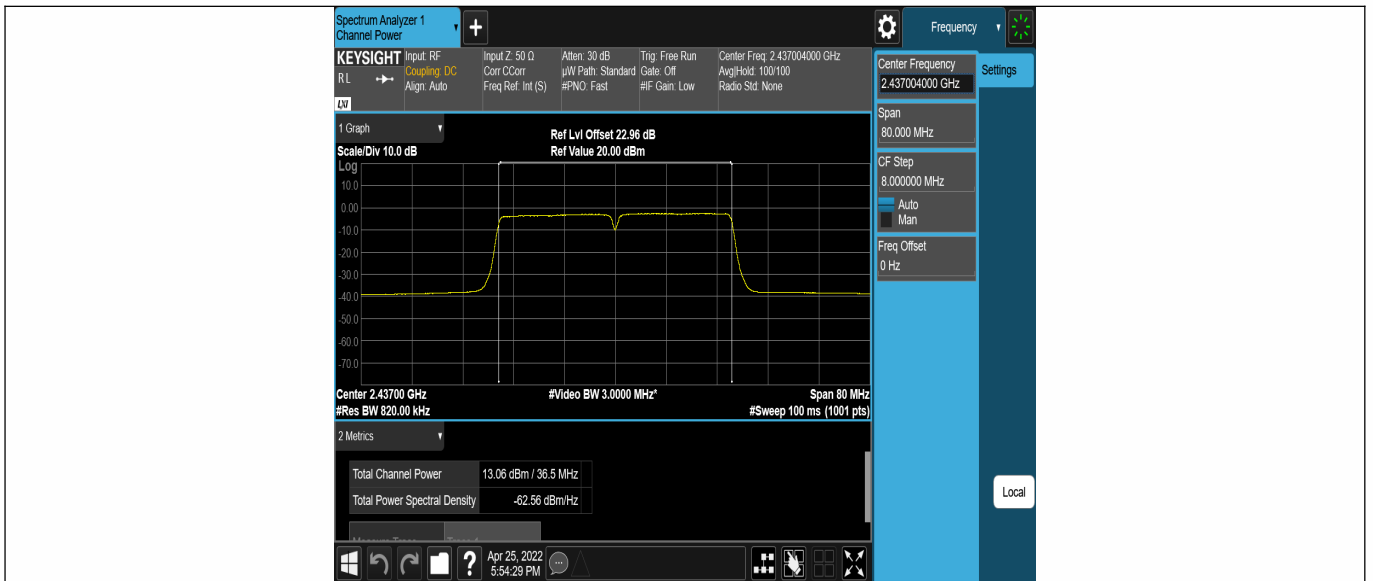

11N40SISO_Ant1_2437

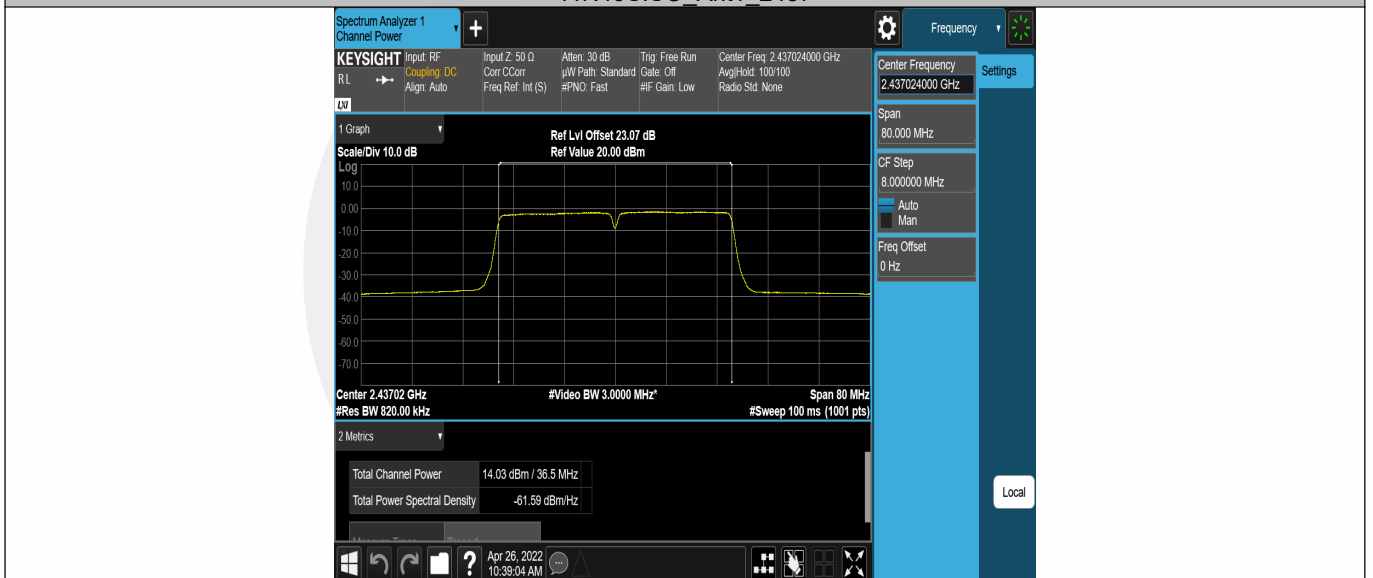

11N40SISO_Ant2_2437

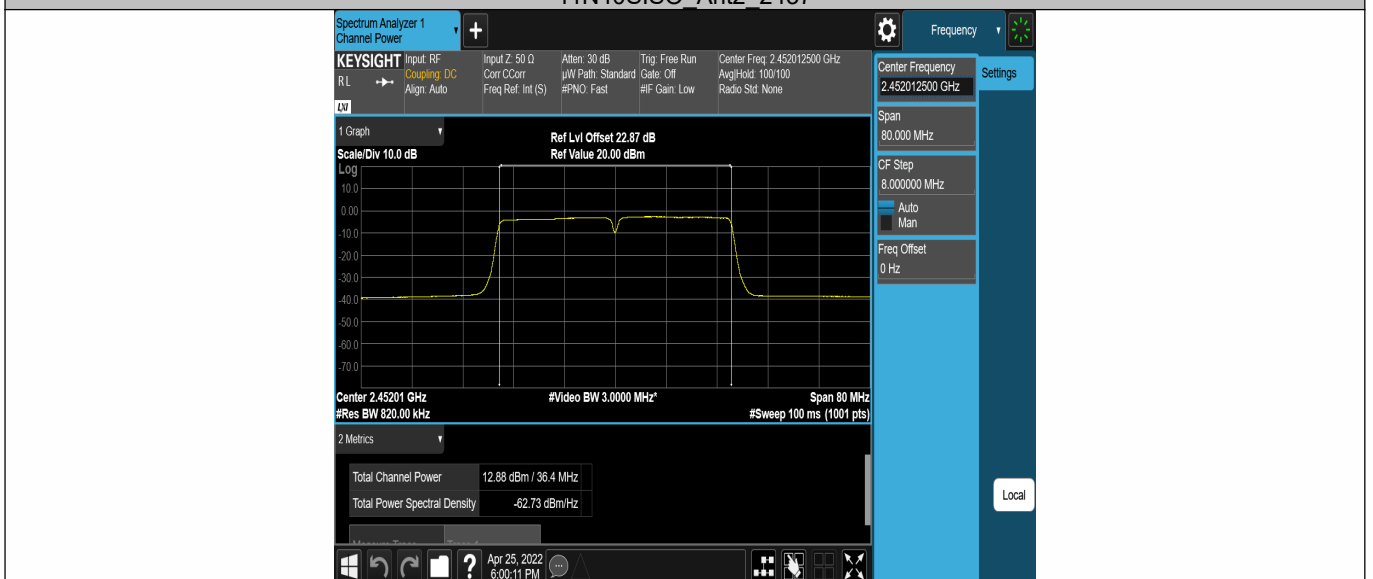

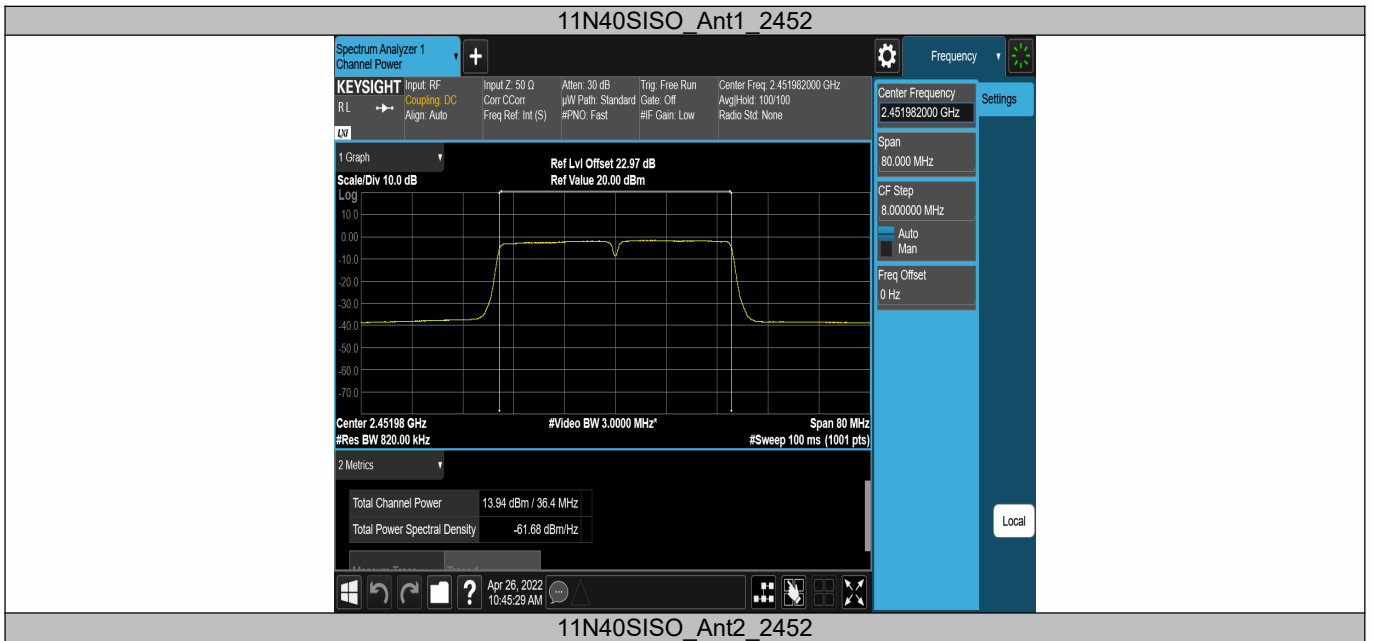

8.3 MAXIMUM POWER SPECTRAL DENSITY

8.3.1 Applicable Standard

According to FCC Part15.247(e) and KDB 558074 D01 15.247 Meas Guidance v05r02

8.3.2 Conformance Limit

The transmitter power spectral density conducted from the transmitter to the antenna shall not be greater than 8 dBm in any 3 kHz band during any time interval of continuous transmission.

8.3.3 Test Configuration

Test according to clause 7.1 radio frequency test setup 1

8.3.4 Test Procedure

This procedure shall be used if maximum peak conducted output power was used to demonstrate compliance

The transmitter output (antenna port) was connected to the spectrum analyzer

Set analyzer center frequency to DTS channel center frequency.

Set the span to 1.5 times the DTS bandwidth.

Set the RBW to: 3 kHz

Set the VBW to:10 kHz.

Set Detector = peak.

Set Sweep time = auto couple.

Set Trace mode = max hold.

Allow trace to fully stabilize.

Use the peak marker function to determine the maximum amplitude level within the RBW.

8.3.5 Test Results

Temperature:	25° C
Relative Humidity:	45%
ATM Pressure:	1011 mbar

TestMode	Antenna	Frequency[MHz]	Result[dBm/3kHz]	Limit[dBm/3kHz]	Verdict
11B	Ant1	2412	-18.22	≤8.00	PASS
	Ant2	2412	-17.24	≤8.00	PASS
	Ant1	2437	-18.39	≤8.00	PASS
	Ant2	2437	-17.23	≤8.00	PASS
	Ant1	2462	-18.34	≤8.00	PASS
	Ant2	2462	-17.43	≤8.00	PASS
11G	Ant1	2412	-20.95	≤8.00	PASS
	Ant2	2412	-19.86	≤8.00	PASS
	Ant1	2437	-20.99	≤8.00	PASS
	Ant2	2437	-20.3	≤8.00	PASS
	Ant1	2462	-21.25	≤8.00	PASS
	Ant2	2462	-20.55	≤8.00	PASS
11N20SISO	Ant1	2412	-21.18	≤8.00	PASS
	Ant2	2412	-20.17	≤8.00	PASS
	Ant1	2437	-21.26	≤8.00	PASS
	Ant2	2437	-20.47	≤8.00	PASS
	Ant1	2462	-21.46	≤8.00	PASS
	Ant2	2462	-20.38	≤8.00	PASS
11N40SISO	Ant1	2422	-24.94	≤8.00	PASS
	Ant2	2422	-24.37	≤8.00	PASS
	Ant1	2437	-25.03	≤8.00	PASS
	Ant2	2437	-24.38	≤8.00	PASS
	Ant1	2452	-25.18	≤8.00	PASS
	Ant2	2452	-24.46	≤8.00	PASS
11N20MIMO		2412	-17.64	≤8.00	PASS
		2437	-17.84	≤8.00	PASS
		2462	-17.88	≤8.00	PASS
11N40MIMO		2422	-21.64	≤8.00	PASS
		2437	-21.68	≤8.00	PASS
		2452	-21.79	≤8.00	PASS

