

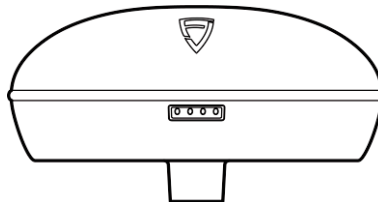

FJD Trion GNSS Receiver User Manual



■ 2022-05-11 | No.SM0001 Rev. 1.0 en-US
©2022 FJDynamics. All rights reserved.



Copyright Notice:

FJDynamics reserves the copyright for this manual and all contents herein. No part of this manual may be reproduced, extracted, reused, and/or reprinted in any form or by any means without the prior written permission of FJDynamics. This manual is subject to change without notice.

Revisions

Version	Date	Description
1.0	2022.05.11	First release



Safety Instructions

Before using this product, make sure that you have read and understood all the operation instructions and precautions in the *FJD Trion GNSS Receiver User Manual*.

Operation Environment:

1. Keep away from people, animals, electrical wires, tall buildings, airports, signal towers, and other obstacles, to avoid interference to GNSS signals and ensure the positioning accuracy.
2. Avoid working in extreme weather such as heavy rain, strong wind, thick fog, snow, and lightning.

Others:

1. Do not disassemble the product without authorization, which may invalidate the warranty.
2. Damages caused by force majeure events, such as lightning strikes, high voltage, and collision, are not covered by the warranty.



3. Use the device in strict accordance with the manual. When connecting cables such as data cables, hold the end of the plug and gently plug or unplug it. Do not pull the plug by force or twist the plug, which may break the pins.
4. Use the regulated power supplies accepted by FJDynamics, and strictly follow the rated voltages, to prevent damaging the radio, the field controller, and the receiver.
5. During charging, keep away from fire sources such as flammables and explosives, to avoid fire and other serious consequences.
6. During operation, do not power the receiver via the Type-C interface and the aviation connector at the same time.
7. Do not plug or unplug cables when the receiver is powered on, and replace the damaged cables in time to avoid personal injury.



Contents

1 About This Document	1
1.1 Introduction.....	1
1.2 GNSS Receiver.....	2
2 Operation Instructions.....	7
2.1 Overview.....	7
2.2 Workflow.....	7
2.2.1 Setup.....	7
2.2.2 Signing up/Logging in to Get Fixed Solution Status.....	11
2.2.3 Parameter Settings	20
2.2.4 Surveying Operation.....	26
2.2.5 Exporting Points.....	35
2.2.6 Other Features	37
2.3 Status Bar.....	48
3 Appendix.....	50
3.1 Specifications	50
3.2 Warranty	56



1 About This Document

1.1 Introduction

The V1t GNSS Receiver developed by FJDynamics has a built-in high-precision IMU (Inertial Measurement Unit) module. With the integration of GNSS and IMU, it supports surveying at any angle, and ensures a positioning accuracy of 3 cm within a tilt angle of 60°. Compared with the V1 GNSS Receiver, the V1t GNSS Receiver has an additional IMU system consisting of a gyroscope and an accelerometer, and is mainly applied in tilt measurement.



1.2 GNSS Receiver

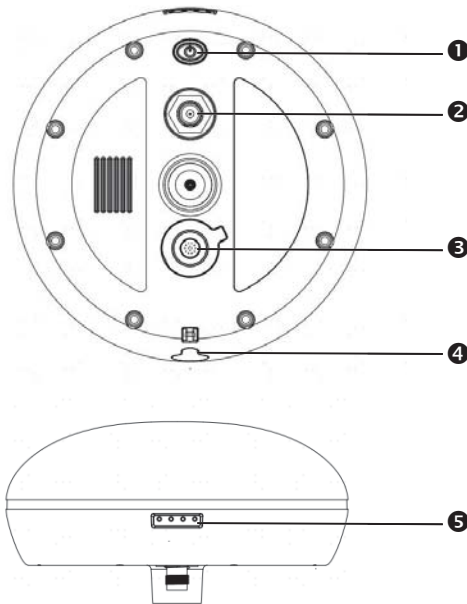

Figure 1.2 Interfaces and indicators



No.	Name	Description
1	Power button	<p>Press and hold for 1 to 3 seconds until the indicator turns solid green, and release the button to turn on the receiver.</p> <p>Press and hold for over 8 seconds to enter the upgrade mode. In this case, the four indicators flash green, blue, green, and blue respectively from left to right.</p> <p>Press and hold for 3 seconds to turn off the receiver.</p>
2	Radio antenna interface	For connection to the radio antenna.
3	Aviation connector interface	For data transmission, and connection to an external power supply or an external radio.
4	Type-C interface	For data transmission and charging.



No.	Description	
5	Power Indicator (red, blue, and green)	Green: battery level of 60%-100%; blue: battery level of 30%-60%; Red: low battery (<30%); Charging: flashes red during charging, and turns solid green after charging is complete.
	Data Indicator (blue and green)	Off: The base station does not transmit differential data, or does not start static collection. Solid green: The data link is established after settings. Flashes green: The differential data is transmitted, and the indicator flashes at the transmission frequency. Flashes blue: In the static mode, the indicator flashes at the collection interval when the interval $\geq 1s$, and flashes at 1s when the interval $< 1s$.
	Satellite Indicator (red and green)	Off: no satellite tracking; Solid green: fixed solution;



No.	Description	
		Flashes green: positioning but not in the fixed solution status; Flashes red: satellite tracking but not positioning; Flashes green and red alternatively: GNSS board exception.
	Bluetooth Indicator (blue)	Off: no Bluetooth connection. On solidly: Bluetooth connection established.
<p>The indicators are in the following colors during upgrade:</p> <p>Power: green Data: blue Satellite: green Bluetooth: blue</p>		



 **Note:**

- Do not plug or unplug the charger repeatedly during charging.
- Do not disassemble the receiver without authorization. In case of a fault, contact the maintenance staff or your dealer.
- Stop using the damaged pole. Repair or replace it in time.

 **Caution**

Burn Hazard

Coverings on the surface of the receiver or the external radio may affect heat dissipation.

- Reduce or remove such coverings.
- Maintain good ventilation.

 **Warning**

Sharp Tips

Sharp tips of the pole may cause personal injury.

- Use the pole with caution.

 **Danger**

Lightning Strikes

Usage of the antenna and the pole in thunderstorms.

- Do not use the antenna and the pole in thunderstorms.



2 Operation Instructions

2.1 Overview

This manual describes the main workflow for the first time use of the product.

2.2 Workflow

Setup → Sign up/log in to get fixed solution status → Set the parameters → Survey → Export the results → Other features

2.2.1 Setup

2.2.1.1 Setting up the External Radio

Set up the tripod over a known point or an unknown point, and install the base station receiver on the extension pole of the tripod, or on the base of the tripod.

!	Note: When setting up a base station over a known point, use a base purchased separately for centering and levelling.
----------	--

The external radio of the base station is set up as below.

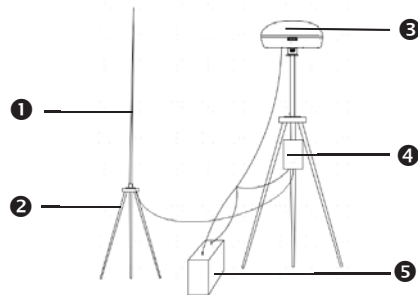

Figure 2.2.1.1-1 External radio of base station

No.	Name	Purpose
1	Radio antenna	External radio antenna.
2	Tripod	Mount the radio antenna on it.
3	Receiver	Receive satellite signals.
4	Radio	External radio.
5	Battery	Power the receiver and the external radio. You are recommended to purchase it separately due to transportation restrictions.

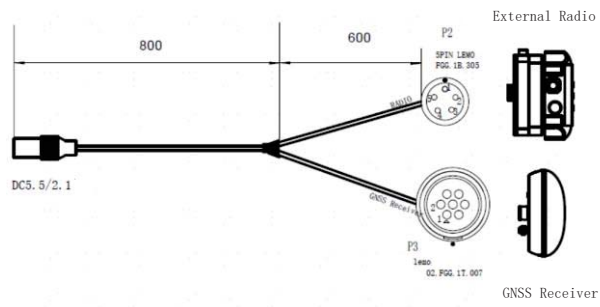

Figure 2.2.1.1-2 Diagram of connection between External radio base station and GNSS Receiver



2.2.1.2 Setting up the Rover

Fix the field controller bracket on the telescopic pole, install the field controller on the bracket, and mount the receiver on the pole.

!	Note: Connection to the radio antenna is required in the radio mode, but not in the network mode.
---	---

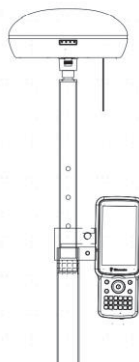

Figure 2.2.1.2 Rover

2.2.1.3 Setting up the Inner Radio

Mount the receiver on the tripod and fix the tripod on the ground.



! Note: The inner radio covers a range of 5-10 km and has high environmental requirements for the operation area.



Figure 2.2.1.3 Inner radio

2.2.2 Signing up/Logging in to Get Fixed Solution Status

2.2.2.1 Sign-up/Login

Sign up: For the first time use, you need to sign up. Tap **Register immediately** to open the sign-up screen, enter your email address, verification code, and password, and then tap



I agree to User Privacy Policy.

Log in: If you have an account already, you can log in directly by entering your user name (email address) and password.

Forgot Password: If you forgot your password, tap **Forgot Password** to reset the password. Enter your email address, verification code, and new password, and then tap **Login** to enter the home screen of the system.

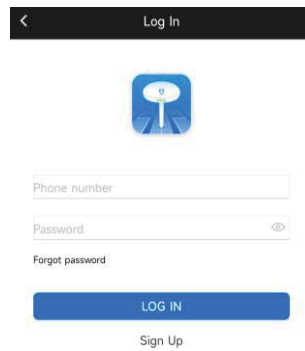

Figure 2.2.2.1 Login screen



2.2.2.2 Establishing the Connection

Choose **Settings** > **Communication**. The options are Bluetooth connection and Wi-Fi connection. Select **Bluetooth**, and tap the device name beginning with "FJD" from **Bluetooth Devices**. **Connected** is displayed after the connection is established.

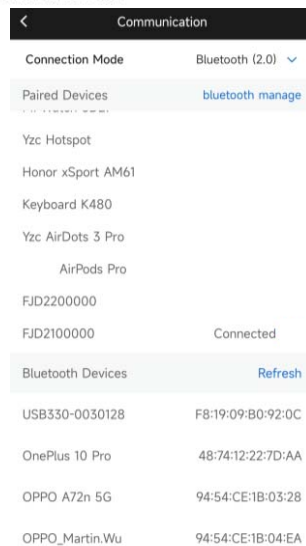

Figure 2.2.2.2 Communication settings



2.2.2.3 Creating a Project

Choose **Project Management > New**, and enter a project name. Select a coordinate system from commonly used ones, and modify parameters such as **Ellipsoid** and **Projection**, or create a new coordinate system based on actual conditions.

The screenshot displays two overlapping mobile application screens. The background screen is titled 'Create Project' and contains the following fields: 'Project Name' with the value 'FJD2022', 'Time Created' with the value '2022-05-20 16:58', and 'Coordinate System' with the value 'Unselected'. The foreground screen is titled 'Coordinate System' and shows a dropdown menu with four options: 'China CGCS 2000' (selected with a blue dot), 'China Xian 80', 'China Beijing 54', and 'China WGS84'. At the bottom of the foreground screen, there are four blue buttons labeled 'CREATE', 'DELETE', 'EDIT', and 'APPLY'.

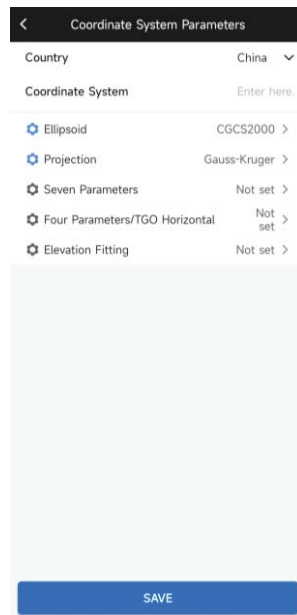

Figure 2.2.2.3-1 Create a project

Ellipsoid: Select the required ellipsoid name, set a (semi-major axis) and $1/f$ (inverse flattening), and tap **OK**.

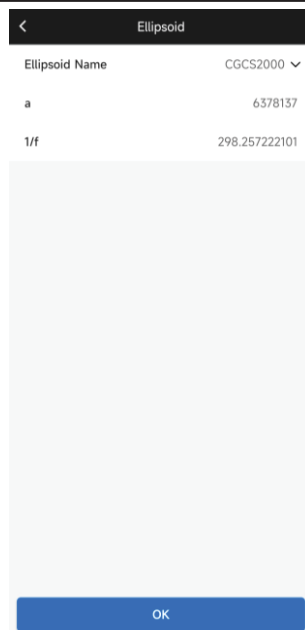



Figure 2.2.2.3-2 Ellipsoid parameters

Projection: Gauss–Krüger projection is commonly used. After the receiver is connected, tap  beside **Central Meridian** to obtain a value automatically or enter a correct value. Projection parameters are usually set as follows: **False Northing** (0), **False Easting** (500000), **Projection Scale** (1),



Projection Height (usually 0 in low altitude areas and can be modified accordingly in high altitude areas), and **Datum Latitude** (0).

Projection	
Projection	Gauss-Kruger
Central Meridian	114:00:00.0000E
Datum Latitude	00:00:00.0000N
False Easting	500000
False Northing	0
Projection Scale	1
Projection Height	0

OK

Figure 2.2.2.3-3 Projection parameters

2.2.2.4 Setting the Rover Mode to Get Fixed Solution Status

Controller Network: Choose **Settings > Rover > Add >**



Controller Network, and tap **OK**. Set the **Connection Mode** as **CORS**, and enter the IP address and port. Tap **Get Source Node**, select a proper source node, enter the user name and password, and tap **Save and Apply**.

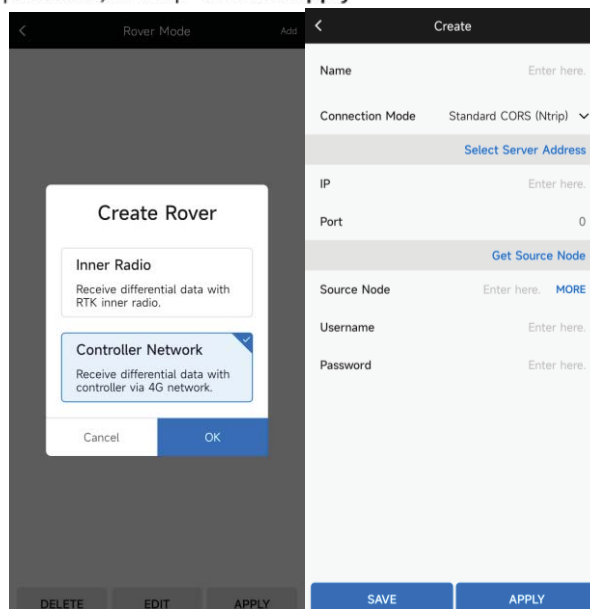

Figure 2.2.2.4-1 CORS network for field controller

Inner Radio: Choose **Add > Inner Radio** and tap **OK**, enter a name, set the **Radio Protocol**, **Channels**, and **Baud Rate** for the base station to be connected, and tap **Save and Apply**.



Note: The rover must have the same radio protocol and number of channels as the base station.

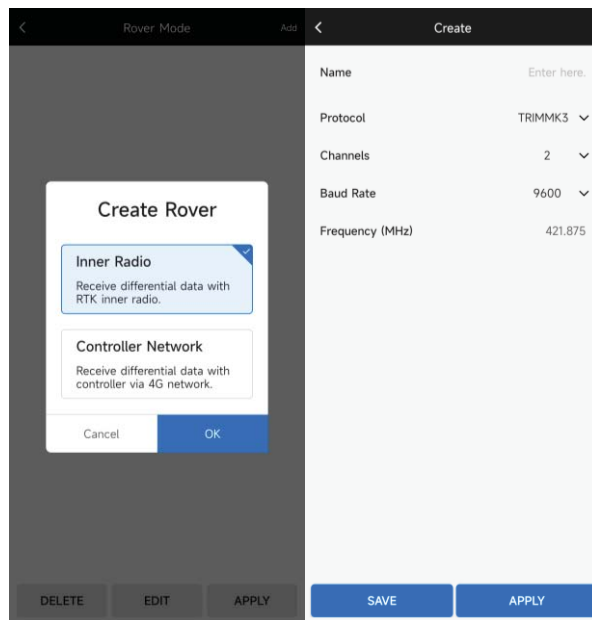

Figure 2.2.2.4-2 Inner radio



2.2.3 Parameter Settings

2.2.3.1 Calibrating Points

Point calibration is to transform measured coordinates into projected coordinates in the rectangular coordinate system. The coordinate systems can be transformed using the existing seven parameters or three parameters. The four parameters and elevation fitting can also be calculated through point calibration using software.

Notes:

1. Ensure that the known points are distributed at the edges of the entire working area to cover the entire area. For example, if four points are used for point calibration, the working area needs to be within the quadrilateral formed by connecting the four points.
2. Ensure that the known points are not linearly distributed. For example, if three known points are used for point calibration, the triangle formed by the three points needs to be as close to an equilateral triangle as possible; and if four known points are used for point calibration, the quadrilateral



formed by the four points needs to be as close to a square as possible. Linear distribution of known points may severely affect the measurement accuracy, especially the elevation accuracy.

3. If the measurement task requires only the horizontal coordinates and does not require the elevation, you are recommended to use at least two points for calibration, but if you need to check the horizontal residuals of the known points, you should use at least three points. If the measurement task requires both the horizontal coordinates and the elevation, you are recommended to use at least three points for calibration, but if you want to check the horizontal residuals and vertical residuals of the known points, you should use at least four points for calibration.

4. Ensure that the coordinate system, the central meridian, the projection plane (especially at high altitudes), the control point, and the S.O. point are in the same projection zone.

5. If more than three control points are used for calibration, check whether the horizontal residual and the vertical residual of each control point meet the measurement



accuracy after calculating the transform parameters. The residual is usually less than 2 cm. If the residual is too large, check whether the known point is correct. If the known point is correct, it does not match and needs to be changed.

Perform the following steps to calibrate points:

Choose **Survey > Calibrate Points**, and tap **Add** to add points used for calibration. Select **Seven Parameters** or **TGO Horizontal and Elevation Fitting for Coordinate Transformation Method** in **Survey > Calibrate Points > Calibration Settings**, tap **OK**, and select the project. Tap **Calculate** at the bottom to obtain the calibration report, and tap **Apply**.



Add Point

Known Point (Control Point)

Name Test1

Coordinate N 3544491.06

Coordinate E 383183.336

Elevation 8.585

Current Point (Measure Point)

Latitude 00:00:00.0000N

Longitude 000:00:00.0000E

Geoid Height 0

Options

Plane Correction (Horizontal)

Elevation Correction

Point Library Management Add

Search by name or number.

Coordinate Lib S.O.

Quantity: 4 Filter

No.	Name	Point Type	Time
<input type="radio"/> 1	pt3		2022-05-30 15:43
<input type="radio"/> 2	pt2		2022-05-30 15:29
<input type="radio"/> 3	pt1		2022-05-30 15:26
<input type="radio"/> 4	base_1		2022-05-30 15:26

CANCEL
OK
DETAILS
IMPORT
ADD
MORE

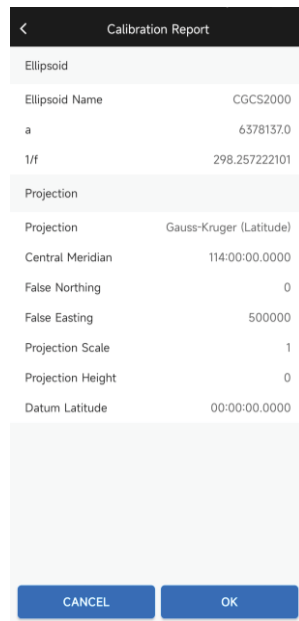

Figure 2.2.3.1 Calibrate points

2.2.3.2 Translating the Base Station

After completing the point calibration, start the measurement operation. If the base station is moved or



restarted in the process, you can calibrate points again in **Survey > Base Station Translation**.

Choose **Survey > Base Station Translation** to enter the **Base Station Translation** screen. Tap the point library icon (the right one) in the upper right corner to select the point coordinates measured on the known points, or tap the collection icon (the left one) in the upper right corner to directly measure the control point coordinates. Tap the point library icon beside **Known Point** and select the known point coordinates from the coordinate library (or directly enter the data below **Known Point**). Tap **Calculate**, so that the software automatically calculates the base station translation, and tap **OK**. A message "Do you want to apply the translation parameters?" is displayed. Tap **Yes** to change the coordinates.



Base Station Translation	
Current Point	
Point Name	Enter here.
Latitude	00:00:00.0000N
Longitude	000:00:00.0000E
Geoid Height	Enter here.
Known Point	
Point Name	Enter here.
Coordinate E	Enter here.
Coordinate N	Enter here.
Elevation	Enter here.
Result	
Base Station Point Name	Enter here.
Northing Translation	0.0
Easting Translation	0.0
Elevation Translation	0.0

Figure 2.2.3.2 Translate the base station

2.2.4 Surveying Operation

2.2.4.1 Surveying Points

Vertical measurement:

1. Choose **Survey > Point Survey** to enter the **Point Survey**





screen. Tap the third icon (from left to right) in the upper right corner to set the receiver antenna height.

2. Put the pole upright on the control point, and keep the level bubble in the center.

3. Tap the **Collect** icon . The collected measure point is automatically saved in the point library.

Tilt measurement:

1. Choose **Survey > Point Survey** to enter the **Point Survey** screen. Tap the third icon (from left to right) in the upper right corner to set the receiver antenna height. Then, tap  to enable the tilt measurement feature.

2. Initialize the tilt measurement feature as prompted. The tilt measurement icon turns into blue  after the initialization succeeds.

3. Enter the point name and tap the **Collect** icon . The collected measure point is automatically saved in the point library.

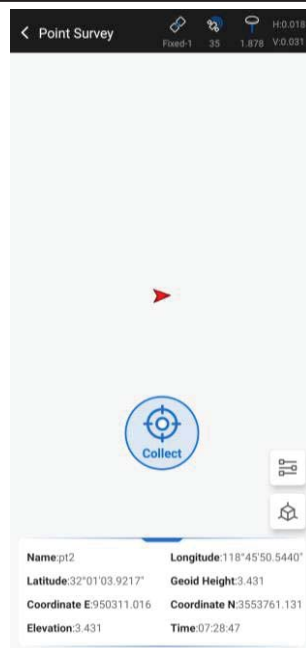

Figure 2.2.4.1 Survey points

Other icons:

 Enters the **Point Library Management** screen where all the points collected with the software are stored. You can add or edit points in the point library.



Enters the **Measurement Parameter Settings** screen, where you can set the observation time, differential delay, and other parameters.



Shows the solution status, which can be Single, Float, RTD, or Fixed.



Enters the positioning information screen of the receiver.



Enters the **Antenna Parameters** screen to set the receiver antenna height.

H: horizontal root mean square, indicating the plane accuracy of the point.

V: vertical root mean square, indicating the elevation accuracy of the point.

2.2.4.2 Staking Out Points

Point stakeout is the process of entering the target coordinates into the software and staking out the point.

Choose **Survey > Point S.O.** and select the point to stake out. Then, the point stakeout screen is displayed.

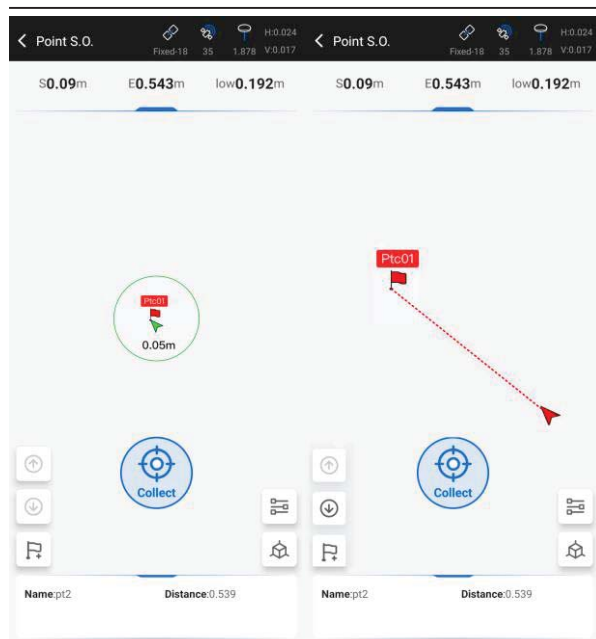

Figure 2.2.4.2 Stake out points

Status bar:

Northing: distance that the receiver needs to travel northwards to reach the stakeout point.

Westing: distance that the receiver needs to travel westwards to reach the stakeout point.





Higher: indicates that the receiver elevation is higher than the target elevation.

Lower: indicates that the receiver elevation is lower than the target elevation.

Other icons:

 Stakes out the previous point.

 Stakes out the next point.

 Adds a stakeout point.

Perform the following steps to stake out points:

1. Select a point from the point library and tap **OK** to open the point stakeout screen. The red flag marks the target point, and the arrow shows the traveling direction of the receiver. When the arrow is aligned to the line between the target point and the current position, follow the arrow to reach the target point.
2. Travel to the coordinates of the stakeout point according to the status bar and fill or cut earth as prompted to eliminate the elevation gap.
3. When the receiver enters the precise stakeout range, a circle



appears, and you can stake out the point precisely as prompted.

4. Tap the up and down arrows to switch to neighboring points in the point library.

2.2.4.3 Staking Out Lines

Line stakeout is the process of staking out a designed straight line, including control of the station distance, left or right offset, and elevation along the straight line.

Choose **Survey > Line S.O.** and select a straight line from the line library. Then, the line stakeout screen is displayed.

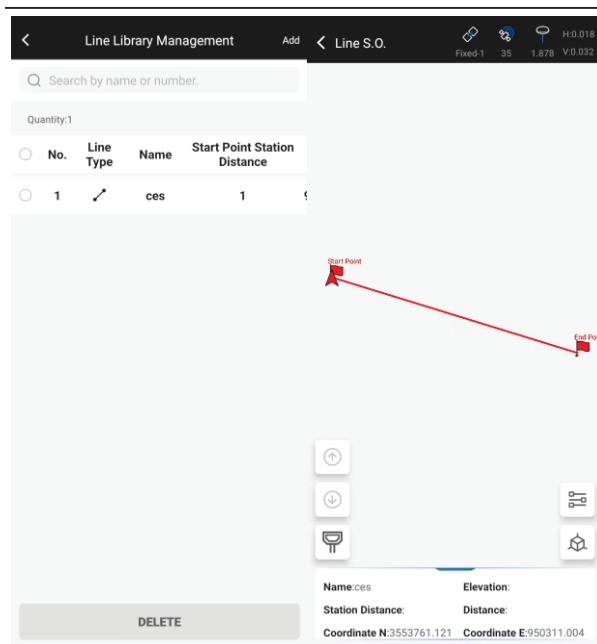

Figure 2.2.4.3-1 Stake out lines

Icons:

- Stakes out the previous line.
- Stakes out the next line.
- Adds stations during line stakeout. You can add a station in either of the following modes: 1) Calculate the coordinates



based on the station distance and offset. In this mode, you need to enter the station distance and offset. 2) Calculate the station distance and offset based on the coordinates. In this mode, you need to enter coordinate N, coordinate E, and elevation, select a point from the point library, or get the current GPS coordinates. Tap **OK** after the settings.

Field	Value / Action	Field	Value / Action
Line Type	Straight line	Line Type	Straight line
Pattern	point coordinates, azimuth, and length	Pattern	Start point and end point coordinates
Line Name	Enter here.	Line Name	Enter here.
Start Point Station Distance	Enter here.	Start Point Station Distance	Enter here.
Azimuth	90:00:00.0000	Start Point	[Location Icon] [GPS Icon]
Length	Enter here.	Start_E	Enter here.
Start Point	[Location Icon] [GPS Icon]	Start_N	Enter here.
Start_E	Enter here.	Start_U	Enter here.
Start_N	Enter here.	End Point	[Location Icon] [GPS Icon]
Start_U	Enter here.	End_E	Enter here.
		End_N	Enter here.
		End_U	Enter here.

Figure 2.2.4.3-2 Add a line



Line Library Management: You can add, edit, delete, and confirm a line in **Line Library Management**.

To add a line, tap **Add**, select the pattern, enter the line name, start point station distance, and other parameters, and then tap **OK**. There are two patterns to add a straight line. One is to enter the start point and end point coordinates, then the azimuth and the length are calculated automatically (the start point station distance is 0 by default). The other one is to enter the start point coordinates, azimuth, and length.

To edit a line, select the line to be edited, tap **Edit** to modify its parameters, and then tap **OK** to save the settings. To delete a line, select the line to be deleted, tap **Delete**, and then tap **OK**.

2.2.5 Exporting Points

Tap **Point Library Management**, select a point and tap **Export**, select the root directory and tap **OK**, select the field type, enter the file name, select the file format, and then tap **OK** to store the data to the selected path.



Point Library Management Add Export Custom

Search by name or number.

Coordinate Lib: S.O. Filter

Quantity: 4

No.	Name	Point Type	Time
1	pt3		2022-05-30 15:43
2	pt2		2022-05-30 15:29
3	pt1		2022-05-30 15:26
4	base_1		2022-05-30 15:26

Field Type: Name,N,E,U

File Path: /storage/emulated/0/Fjdynamics/output/

File Name: Enter the file name.

Contain Field Name:

Format: dd.dddddd

File Format: CSV (*.csv)

DETAILS IMPORT ADD MORE OK



Figure 2.2.5 Export points

2.2.6 Other Features

2.2.6.1 Coordinate System

Tap **Projects > Coordinate System** to set the parameters.

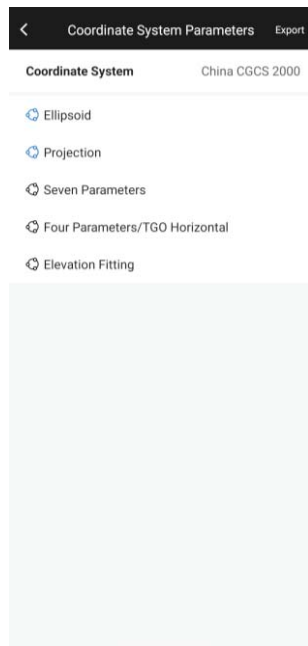

Figure 2.2.6.1-1 Coordinate system

Ellipsoid: You can use the defined ellipsoid parameters, or set the **a** and **1/f**. The ellipsoid in the coordinate system should be consistent with the ellipsoid selected when creating a new project.



Ellipsoid	
Ellipsoid Name	CGCS2000
a	6378137
1/f	298.257222101

OK

Figure 2.2.6.1-2 Ellipsoid parameters

Projection: Gauss-Krüger projection is commonly used. After the receiver is connected, tap  beside **Central Meridian** to obtain a value automatically or enter a correct value. Projection parameters are usually set as follows: **False Northing** (0), **False Easting** (500000), **Projection Scale** (1), **Projection Height** (usually 0 in low altitude areas and can be



modified accordingly in high altitude areas), and **Datum Latitude**(0).

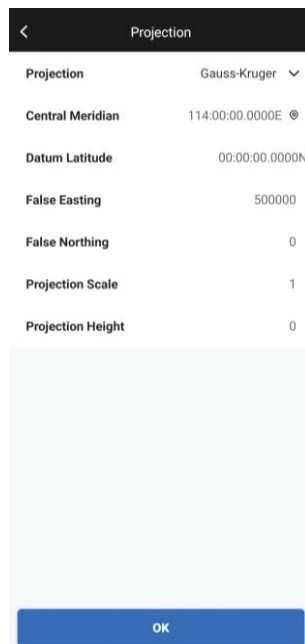

Figure 2.2.6.1-3 Projection parameters

Seven Parameters: Seven-parameter transformation model (mathematical system of equations) is usually used for the transformation between two different three-dimensional



rectangular coordinate systems. At least six sets of XYZ coordinates of three commonly known points in two different space rectangular coordinate systems are required to calculate the seven unknown parameters. Then, the XYZ coordinates of a point in one space rectangular coordinate system can be transformed into the XYZ coordinates in another using the seven-parameter transformation model.

The seven unknown parameters in the seven-parameter transformation model are:

- (1) Three coordinate translation quantities (ΔX , ΔY , and ΔZ), that is, the coordinate difference between the coordinate origins of two space coordinate systems;
- (2) Rotation angles ($\Delta\alpha$, $\Delta\beta$, and $\Delta\gamma$) of three coordinate axes (X, Y, and Z). Rotate the three coordinate axes by the corresponding angle in sequence, then the XYZ axes of the two space rectangular coordinate systems can coincide;
- (3) Scale factor K, that is, the length ratio of the same straight line in two space coordinate systems for scale conversion;

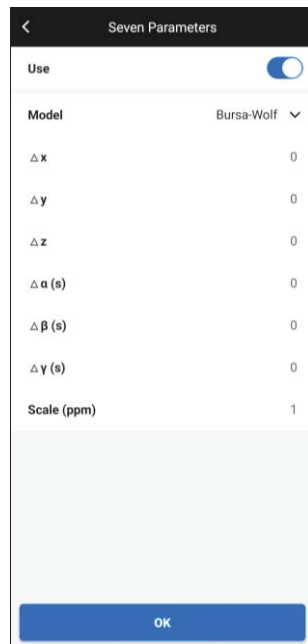

Figure 2.2.6.1-4 Seven parameters

Four Parameters: At least four sets of XY coordinates of two commonly known points in two different rectangular plane coordinate systems are required to calculate the four unknown parameters. Then, the XY coordinates of a point in one rectangular plane coordinate system can be transformed



into the XY coordinates in another using the four-parameter transformation model.

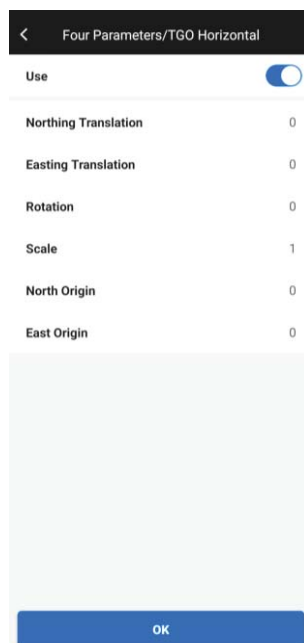

Figure 2.2.6.1-5 Four parameters

2.2.6.2 Managing the Point Library

Tap **Projects > Point Library Management**. Use the point



library to manage the points. You can add points in the library for future operations such as point stakeout. You can quickly locate a point by name or number. You can add, edit, view details of, delete, import, and export a point in **Point Library Management**.

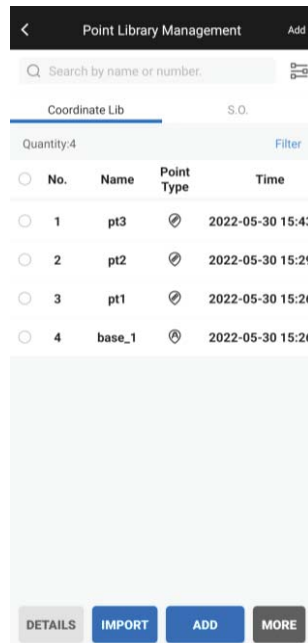

Figure 2.2.6.2-1 Manage the point library



Tap **Add**, as shown in Figure 2.2.6.2-2. The points can be divided into projected coordinates and geodetic coordinates by coordinate types, or control points, input points, S.O. points, and auxiliary points by attribute types. To add a point, select the coordinate type and attribute. Then, enter the name, coordinate E, coordinate N, and elevation for projected coordinates, or enter the name, latitude, longitude, and geoid height for geodetic coordinates.



Add	
Type	Projected coordinates ▾
Name	Enter here.
Coordinate E	Enter here.
Coordinate N	Enter here.
Elevation	Enter here.
Attribute Type	Input point ▾

CREATE

Figure 2.2.6.2-2 Add a point

Tap a point to see its details, such as its name, longitude, latitude, and projected coordinates (coordinate N, coordinate E, and elevation), as shown in Figure 2.2.6.2-3.



<
Point Details

General	Satellite
Survey	
Name	pt3
Time	2022-05-30 15:43:50
Longitude	118°45'50.5434"
Latitude	32°01'03.9215"
Geoid Height	3.448
Coordinate E	950311.001
Coordinate N	3553761.125
Elevation	3.448
Point Type	Measure point
Antenna type	
Antenna Height	1.878
Base	
Name	0
Base Center Antenna Height	0.0

EDIT
SAVE

Figure 2.2.6.2-3 Point details



2.3 Status Bar

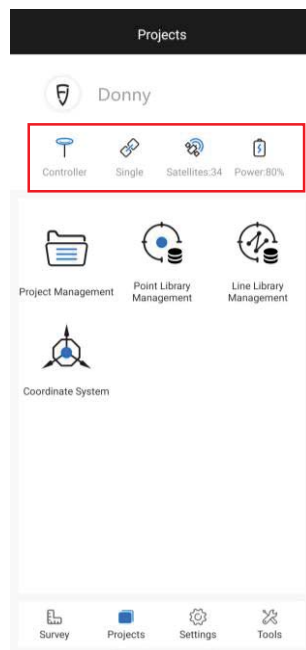

Figure 2.3 Status bar

1. Receiver status. It can be one of the following:

Unknown: The receiver is not connected.

Ex Radio: The receiver is set to the base station mode and



uses the external radio for data transmission.

In Radio: The receiver is set to the base station mode and uses the inner radio for data transmission.

Controller Network: The receiver is connected to the CORS network through the controller network.

2. Differential processing status: Fixed solution, float solution, and single point solution. When it shows **Fixed**, the differential processing status is normal.

3. Number of visible satellites: It shows how many satellites are visible.

4. Power level: It shows the current power level in percentage. When the power level is 0, the system will automatically turn off.



3 Appendix

3.1 Specifications

GNSS		
GNSS	Signal tracking	GPS: L1C/A
Items marked with * will be updated with the firmware.		
	Time to first fix	< 20s (cold start)
		< 10s (hot start)
	Signal reacquisition	< 1s



	Pseudorange accuracy	≤ 10 cm
	Carrier phase accuracy	≤ 1 mm
	RTK initialization time	< 5s (baseline < 10 km)
	Initialization reliability	> 99.9%
	Channels	965
	GNSS positioning accuracy	Single-point positioning (RMS): horizontal 1.5 m, vertical 3 m;
		Static differential (RMS): horizontal $\pm (2.5+1 \times 10^{-6} \times D)$ mm, vertical $\pm (5.0+1 \times 10^{-6} \times D)$ mm D refers to baseline length, unit: km.



		RTK (RMS): horizontal $\pm (8+1*10^{-6}*D)$ mm, vertical $\pm (15+1*10^{-6}*D)$ mm *D refers to baseline distance, unit: km.
	Timing accuracy	20 ns
	Update rate	Raw observation data: 1, 2, 5, 10 Hz Real-time positioning data: 1, 2, 5, 10 Hz
	Data format	RTCM2.X, RTCM3.X, CMR, CMR+, CMRx, NMEA-0183, RINEX
Bluetooth	Protocol	BLE
Wi-Fi	Protocol	IEEE 802.11b/g/n standards
INS	Tilt measurement	10 mm + 0.7 mm/tilt (for a tilt of no larger than 30°, the accuracy is < 2.5 cm)
Built-in Radio	Power consumption	0.5 W/1 W
	Modulation type	DSSS, OFDM, GFSK



	Frequency	902-928MHz
	Protocol	TRIMATLK, TRIMMARK3, PCC EOT
Battery	Battery capacity	6500 mAh
	Battery life	Static measurement: 10 h, dynamic measurement: 15 h
Power Supply	Voltage	Rated input voltage: 12 V DC; input voltage range: 9 V - 32V
Indicator	Type	Power, data, satellite and Bluetooth
Overall	Size	Ø162mm x 86 mm
	Weight	≤ 1 kg
	IP rating	IP67
Ambient Environment	Operating temperature	20°C - 60°C
	Storage temperature	-40°C - 70°C
	Humidity	95%



Field Controller		
System	OS	Android 8.1
	CPU	Octa-core 2.0 GHz processor
	ROM expandable	Up to 128 GB
	SIM card	Dual card single pass
	RAM	4 GB
	ROM	64 GB
GNSS Performance	Signals received	GPS/BDS/GLONASS
	Update rate	1 Hz - 10 Hz
Data Communication	Bluetooth	
	Wi-Fi	IEEE 802.11 b/g/n
	Network	BLE
Screen and Keyboard	Screen size	5-inch sunlight readable touchscreen
	Resolution	720 × 1280
	Keyboard	2 volume buttons, 30 key, 1 power button



Field Controller		
Battery	Battery capacity	6500 mAh
	Charging voltage	7.2V
	Battery life	≥ 10 h
	Maximum charging current	1.1 A



3.2 Warranty

Upholding the user-centered principle, FJ Dynamics Co., Ltd. (FJD), as a leading machinery and smart driving system manufacturer, provides the following warranty for each FJD Trion GNSS receiver:

1. Warranty period: A warranty period of 1 year is granted to each user (including lifetime free software upgrade). The period starts from the invoice date and expires on the date stipulated in this warranty.
2. If the receiver or any of its parts fails during the warranty period, the dealer shall repair or replace the damaged part free of charge. If warranty for the damaged part has expired, the user shall pay for the new part and the repair service provided by the dealer.
3. Within the warranty period, if the receiver is damaged due to improper use, maintenance, or adjustment by the user or for reasons other than product quality issues, the user shall pay for the new part, while the dealer shall provide the repair service free of charge.



4. The dealer shall also provide free training and services for the software system within the warranty period.

5. Warranty period: 1 year.

6. FJD reserves all rights to interpret this warranty.

Warning:

Operation of this equipment in a residential environment could cause radio interference.

FCC Compliance Notice

This device complies with part 15 of the FCC Rules. Operation is subject to the following two conditions:

- (1) This device may not cause harmful interference, and
- (2) this device must accept any interference received, including interference that may cause undesired operation. Any changes or modifications not expressly approved by the party responsible for compliance could void the user's authority to operate the equipment.

This equipment has been tested and found to comply with the limits for a Class B digital device, pursuant to part 15 of the FCC Rules. These limits are designed to provide reasonable protection against harmful interference in a residential installation. This equipment generates, uses and can radiate radio frequency energy and, if not installed and used in accordance with the instructions, may cause harmful interference

to radio communications. However, there is no guarantee that interference will not occur in a particular installation. If this equipment does cause harmful interference to radio or television reception, which can

be determined by turning the equipment off and on, the user is encouraged to try to correct the interference by one or more of the following measures:

- Reorient or relocate the receiving antenna.
- Increase the separation between the equipment and receiver.
- Connect the equipment into an outlet on a circuit different from that to which the receiver is connected.
- Consult the dealer or an experienced radio/TV technician for help.

FCC Radiation Exposure Statement

This equipment complies with FCC radiation exposure limits set forth for an uncontrolled environment . This transmitter must not be co-located or operating in conjunction with any other antenna or transmitter. This equipment should be installed and operated with minimum distance 20cm between the radiator& your body.

FJ Dynamics Co., Ltd.

				
AT	BE	CY	CZ	DK
EE	FI	FR	DE	EL
HU	IE	IT	LV	LT
LU	MT	NL	PL	PT
SK	SI	ES	SE	BG
RO	HR			



©2022 FJDynamics. All rights reserved.