



## Capsule Sensor V3

-Tiny fun IoT Device





## Document version

Version	Time	Description	Remark
V1.0	2024-01-16	Documents creating	Richard

## Copyright Notice

All contents in the files are protected by copyright law, and all copyrights are reserved by Chengdu Heltec Automation Technology Co., Ltd. (hereinafter referred to as Heltec). Without written permission, all commercial use of the files from Heltec are forbidden, such as copy, distribute, reproduce the files, etc., but non-commercial purpose, downloaded or printed by individual are welcome.

## Disclaimer

Chengdu Heltec Automation Technology Co., Ltd. reserves the right to change, modify or improve the document and product described herein. Its contents are subject to change without notice. These instructions are intended for you use.



# Content

<b>Capsule Sensor V3</b> .....	<b>1</b>
<i>Document version</i> .....	<i>2</i>
<i>Copyright Notice</i> .....	<i>2</i>
<i>Disclaimer</i> .....	<i>2</i>
<i>Content</i> .....	<i>3</i>
<b>1. Description</b> .....	<b>4</b>
1.1 Overview .....	4
1.2 Product features .....	5
1.3 Application scenarios .....	5
<b>2. Specifications</b> .....	<b>6</b>
2.1 General specifications .....	6
2.2 Flash Partitions .....	6
2.3 Electrical Characteristics .....	7
2.4 LoRa RF Characteristics .....	7
<b>3. Physical Dimensions</b> .....	<b>9</b>
<b>4. Resource</b> .....	<b>9</b>
4.1 Relevant Resource .....	9
4.2 Contact Information .....	9



# 1. Description

## 1.1 Overview

Capsule Sensor V3 is a tiny portable LoRa/LoRaWAN device based on ESP32-S3 and SX1262. Modular design allows it to adapt to different sensors, so you can easily build applications without being an expert in IoT.

Thanks to WirelessBoot<sup>1</sup> technology, Capsule Sensor V3 is small, stylish, waterproof, and has a 250mA rechargeable battery, making it perfect for complex environments.

Whether you want to build your applications or run open-source programs like Meshtastic<sup>2</sup>, Capsule Sensor V3 is a great choice.

Capsule Sensor are available in two product variants:

Table 1.1: Product model list

No.	Model	Description
1	Capsule Sensor - 433	For 433MHz LoRa frequency
2	Capsule Sensor - 470to510	For 470~510MHz working LoRa frequency, used for China mainland (CN470) LPW band.
3	Capsule Sensor - 863to870	For EU868, IN865 and other LPW networks with operating frequencies between 863~870MHz.
4	Capsule Sensor - 902to928	For US915, AU915, AS923, KR920 and other LPW networks with operating frequencies between 902~928MHz

<sup>1</sup> You can understand it as a special OTA program, but it can running in the devices' Boot loader.

<sup>2</sup> We programmed Meshtastick to be low power and equipped with a 'Type-C to magnetic suction' charging cable.



## 1.2 Product features

- ESP32-S3 + SX1262.
- Wireless communication method include Wi-Fi, Bluetooth and LoRa.
- Modular design, with a BTB interface reserved at the bottom, capable of connecting and replacing different sensors.
- Built in 250mAh rechargeable battery, magnetic suction charging port.
- Built in LoRa and Wi-Fi/BLE antennas, stylish appearance, compact and light.
- High strength plastic, IP65 waterproof.
- Support Heltec Wireless Boot system, download firmware, exchange information, and print logs through Wi-Fi.
- Meshtastic compatible.
- Secondary development can be done through Arduino, Platform.io, etc.

## 1.3 Application scenarios

CapSule's application is mainly realized by replacing the sensor module, and here are just some typical application scenarios.

- Environmental monitoring;
- Data converter;
- Asset/pet/person tracking;
- Children education;
- [Meshtastic](#);
- As a common Arduino development board.



## 2. Specifications

### 2.1 General specifications

Table 2-1: General specifications

Parameters	Description
MCU	ESP32-S3FN8
LoRa Chip	SX-1262
Memory	384KB ROM; 512KB SRAM; 16KB RTC SRAM; 8MB SiP
Frequency	433MHz, 470~510MHz, 863~870MHz, 902~928MHz
Max TX Power	21 ± 1dBm
Receiving sensitivity	-135dBm
Wi-Fi	802.11 b/g/n
Bluetooth	Bluetooth LE: Bluetooth 5, Bluetooth mesh
Charging	5V, Magnetic 2P-2.54mm
Battery	250mAh
Protection grade	IP65
Operating temperature	-20 ~ 60°C
Dimensions	47mm * 26mm φ

### 2.2 Flash Partitions

Name	Type	SubType	Offset	Size
nvs	data	nvs	0x009000	0x005000
otadata	data	ota	0x00e000	0x002000

<https://heltec.org>



app	app	ota_0	0x010000	0x250000
flashApp	app	ota_1	0x260000	0x0A0000
spiffs	data	spiffs	0x300000	0x100000
factory	app	factory	0x400000	0x100000
secondApp	app	ota_2	0x500000	0x2D0000

## 2.3 Electrical Characteristics

Table 2-2: Power supply

Parameter		Typical	Unit
Power Supply	Charging	5	V
	Battery	3.0~4.1	V
Consumption	LoRa Sending	230	mA
	LoRa Receiving	90	mA
	Sleep	25	uA

## 2.4 LoRa RF Characteristics

### 2.4.1 Transmit Power

Table2-3-1: Transmit power

Operating frequency band	Maximum power value/[dBm]
470~510	21 ± 1
867~870	21 ± 1
902~928	21 ± 1



## 2.4.2 Receiving Sensitivity

The following table gives typically sensitivity level of the Capsule Sensor.

Table2-3-2: Receiving sensitivity

Signal Bandwidth/[KHz]	Spreading Factor	Sensitivity/[dBm]
125	SF12	-135
125	SF10	-130
125	SF7	-124

## 2.4.3 Operation Frequencies

Capsule supports LoRaWAN frequency channels and models corresponding table.

Table2-3-3: Operation Frequencies

Region	Frequency (MHz)
EU433	433.175~434.665
CN470	470~510
IN868	865~867
EU868	863~870
US915	902~928
AU915	915~928
KR920	920~923
AS923	920~925



### 3. Physical Dimensions

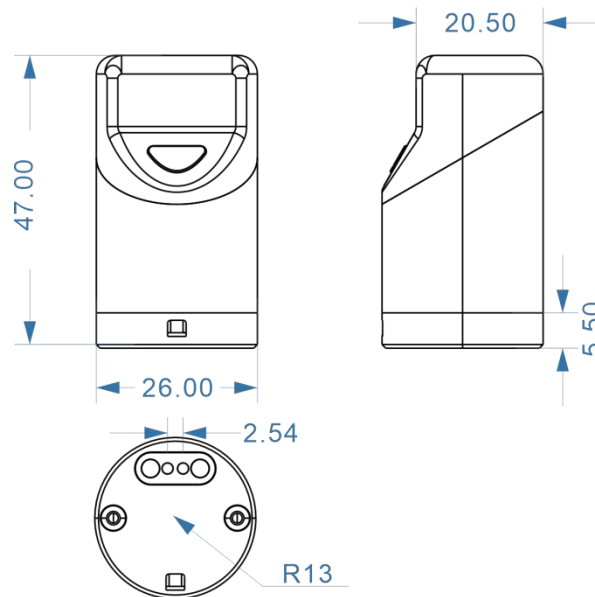

### 4. Resource

#### 4.1 Relevant Resource

- [Heltec ESP32 framework](#) (Already included Heltec ESP32 LoRaWAN library)
- [Heltec LoRaWAN test server based on TTS V3](#)
- [User Manual Document](#)
- [Wireless Boot instructions](#)

#### 4.2 Contact Information

Heltec Automation Technology Co., Ltd

Chengdu, Sichuan, China

Email: [support@heltec.cn](mailto:support@heltec.cn)

Phone: +86-028-62374838

<https://heltec.org>

<https://heltec.org>

FCC Warning:

This equipment has been tested and found to comply with the limits for a Class B digital device, pursuant to part 15 of the FCC Rules. These limits are designed to provide reasonable protection against harmful interference in a residential installation. This equipment generates, uses and can radiate radio frequency energy and, if not installed and used in accordance with the instructions, may cause harmful interference to radio communications. However, there is no guarantee that interference will not occur in a particular installation. If this equipment does cause harmful interference to radio or television reception, which can be determined by turning the equipment off and on, the user is encouraged to try to correct the interference by one or more of the following measures:

- Reorient or relocate the receiving antenna.
- Increase the separation between the equipment and receiver.
- Connect the equipment into an outlet on a circuit different from that to which the receiver is connected.
- Consult the dealer or an experienced radio/TV technician for help.

Caution: Any changes or modifications to this device not explicitly approved by manufacturer could void your authority to operate this equipment.

This device complies with part 15 of the FCC Rules. Operation is subject to the following two conditions:

(1) This device may not cause harmful interference, and (2) this device must accept any interference received, including interference that may cause undesired operation.

This equipment complies with FCC radiation exposure limits set forth for an uncontrolled environment. This equipment should be installed and operated with minimum distance 0cm between the radiator and your body.