



Galaxy Star Projector User Manual

MODEL NO: HS-06

Thank you for choose Galaxy Star Projector. Read all information below before use so that you can use it properly.

01

PRODUCT DESCRIPTION

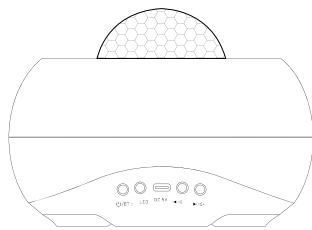

Galaxy Star Projector



Remote Control

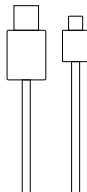

USB Cable

02

FUNCTION BUTTON

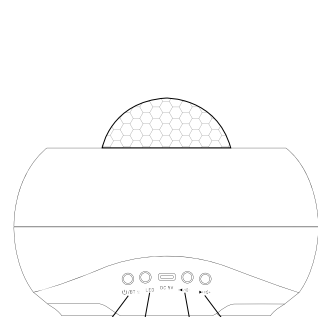

Power Button

Mode Switch

Volume Up

Volume Down

03

REMOTE CONTROL

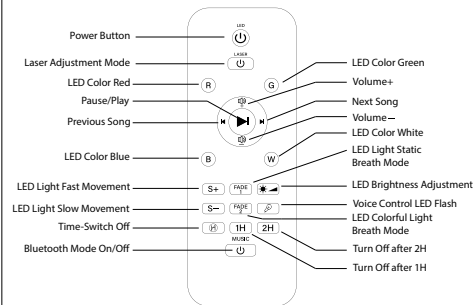

Remote control instructions:

LED light switch click to turn on or off the lights

Laser switch, click to turn on to turn off the laser light

Press the red, green, blue and white buttons to turn on or off the corresponding lights

Volume adjustment, click to increase or decrease volume

Motor speed adjustment, press S+ to turn on the motor slowly, then press S+ to increase the speed,

press S- to turn off the motor

The brightness of the lamp is adjusted to three levels. The brightness of the power-on is 100%.

Press it once to 60%, press 30% again, press it again to 60%, press 100% again, and the cycle continues.

04

PRODUCT SPECIFICATION

Color	Black / White
Style	Red Green Blue White
Light Source Type	LED
Power Source	Corded Electric
Controller Type	Remote Control
Wattage	6.5 Watts
Remote Control Distance	5 M

05

USER MANUAL

1.Press and hold the first button for 2 seconds to turn on or turn off, and short press the Bluetooth audio function when it is turned on;

2.The second button is to switch the lighting mode, short press to switch between bright monochrome, monochrome red, green, blue and white breathing slowly, colorful light breathing slowly, voice control change mode, long press to switch the laser light;

3.Short press the third button to decrease the volume, long press the previous song; (the third button silkscreen is -)

4.Short press the fourth button to increase the volume, long press a song; (the silk screen of the fourth button is +)

06

SAFETY INSTRUCTIONS

- 1.Do not modify or repair this product.
- 2.It is forbidden to use voltages other than 120V AC, which may cause damage, fire and electric shock.
- 3.Do not excessively bend, pull or twist the power cord, which may damage the power cord and cause a fire.
- 4.Do not expose the host to rain or other liquids.
- 5.Do not touch the power plug with wet hands.
- 6.Do not use the device in the place which with propane, gas, natural gas, or any other flammable.
- 7.Please keep the device stored in dry places.



ACTIVATE WARRANTY FREE 2 - YEARS



Scan or Enter
Online-warranty.net

WARRANTY CARD

Activate here 7-days
Extend warranty for 1-year
<http://www.aoogmail.com>



Need help? Contact
yoabomall@gmail.com

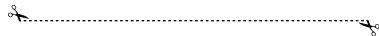

Prime Membership Benefits



Member
Gift



Member
Shopping Privilege



Dedicated
customer service



Giveaway
Gift



New
Releases



More

Welcome to Join The Club Membership Program Join Shop
Members to Enjoy Exclusive Rights

Fantastic Light Show

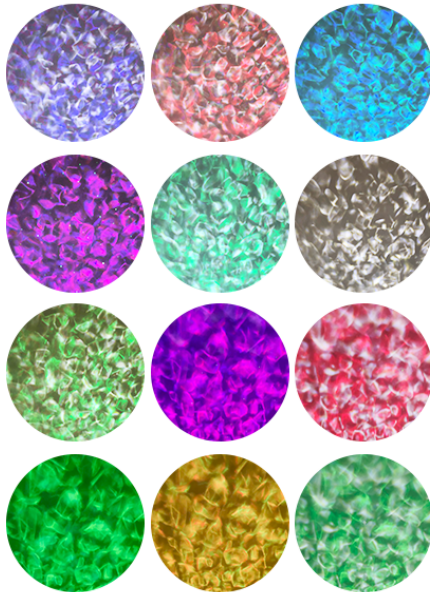

FCC WARNING

This device complies with part 15 of the FCC Rules. Operation is subject to the following two conditions: (1) this device may not cause harmful interference, and (2) this device must accept any interference received, including interference that may cause undesired operation.

Any changes or modifications not expressly approved by the party responsible for compliance could void the user's authority to operate the equipment.

NOTE: This equipment has been tested and found to comply with the limits for a Class B digital device, pursuant to Part 15 of the FCC Rules. These limits are designed to provide reasonable protection against harmful interference in a residential installation. This equipment generates, uses and can radiate radio frequency energy and, if not installed and used in accordance with the instructions, may cause harmful interference to radio communications.

However, there is no guarantee that interference will not occur in a particular installation.

If this equipment does cause harmful interference to radio or television reception, which can be determined by turning the equipment off and on, the user is encouraged to try to correct the interference by one or more of the following measures:

- Reorient or relocate the receiving antenna.
- Increase the separation between the equipment and receiver.
- Connect the equipment into an outlet on a circuit different from that to which the receiver is connected.
- Consult the dealer or an experienced radio/TV technician for help.

To maintain compliance with FCC's RF Exposure guidelines, This equipment should be installed and operated with minimum distance between 20cm the radiator your body: Use only the supplied antenna.