



TEST REPORT

For FCC Part15B

Report No.: **CHTEW22090143** Report verification: 

Project No.: **SHT2205063201EW**

FCC ID.....: **2A2CXFBLB003**

Applicant's name.....: **Suijimanbu (SHANGHAI) Sports Technology Co.Ltd.**

Address.....: Room 507, Zone C, No. 1188, Tianyaoqiao Road, Xuhui District, Shanghai

Product Name: **Lit Bike**

Trade Mark: freebeat.

Model No.: Lit Bike

Listed Model(s): -

Standard: **47 CFR FCC Part 15 Subpart B**

Date of receipt of test sample.....: Aug. 17, 2022

Date of testing.....: Aug. 18, 2022- Sep. 28, 2022

Date of issue.....: Sep. 29, 2022

Result.....: **Pass**

Compiled by
 (position+printed name+signature)...: File administrators Silvia Li

Supervised by
 (position+printed name+signature)...: Project Engineer Caspar Chen

Approved by
 (position+printed name+signature)...: RF Manager Hans Hu

Silvia Li

Caspar Chen

Hans Hu

Testing Laboratory Name: **Shenzhen Huatongwei International Inspection Co., Ltd.**

Address.....: 1/F, Bldg 3, Hongfa Hi-tech Industrial Park, Genyu Road, Tianliao, Gongming, Shenzhen, China

Shenzhen Huatongwei International Inspection Co., Ltd. All rights reserved.

This publication may be reproduced in whole or in part for non-commercial purposes as long as the Shenzhen Huatongwei International Inspection Co., Ltd. is acknowledged as copyright owner and source of the material. Shenzhen Huatongwei International Inspection Co., Ltd. takes no responsibility for and will not assume liability for damages resulting from the reader's interpretation of the reproduced material due to its placement and context.

The test report merely corresponds to the test sample.

Contents

| | | |
|-----------|---|------------------|
| 1. | <u>TEST STANDARDS AND REPORT VERSION</u> | <u>3</u> |
| 1.1. | Test Standards | 3 |
| 1.2. | Report version information | 3 |
| 2. | <u>TEST DESCRIPTION</u> | <u>4</u> |
| 3. | <u>SUMMARY.....</u> | <u>5</u> |
| 3.1. | Client Information | 5 |
| 3.2. | Product Description | 5 |
| 3.3. | Testing Laboratory Information | 5 |
| 4. | <u>TEST CONFIGURATION.....</u> | <u>6</u> |
| 4.1. | Descriptions of test mode | 6 |
| 4.2. | Configuration of Tested System | 6 |
| 4.3. | Support unit used in test configuration and system | 7 |
| 4.4. | Environmental conditions | 7 |
| 4.5. | Statement of the measurement uncertainty | 7 |
| 4.6. | Equipments Used during the Test | 8 |
| 5. | <u>TEST CONDITIONS AND RESULTS.....</u> | <u>9</u> |
| 5.1. | Conducted Emissions | 9 |
| 5.2. | Radiated Emissions | 11 |
| 6. | <u>TEST SETUP PHOTOS</u> | <u>15</u> |
| 7. | <u>EXTERNAL AND INTERNAL PHOTOS</u> | <u>16</u> |

1. TEST STANDARDS AND REPORT VERSION

1.1. Test Standards

The tests were performed according to following standards:

[47 CFR FCC Part 15 Subpart B](#) - Unintentional Radiators

[ANSI C63.4: 2014](#) – American National Standard for Methods of Measurement of Radio-Noise Emissions from Low-Voltage Electrical and Electronic Equipment in the Range of 9 kHz to 40GHz

1.2. Report version information

| Revision No. | Date of issue | Description |
|--------------|---------------|-------------|
| N/A | 2022-09-29 | Original |
| | | |
| | | |
| | | |
| | | |

2. TEST DESCRIPTION

| Section | Test Item | Section in CFR 47 | Result #1 | Test Engineer |
|---------|---------------------|-------------------|-----------|---------------|
| 5.1 | Conducted Emissions | 15.107(a) | PASS | Pan Xie |
| 5.2 | Radiated Emissions | 15.109(a) | PASS | Pan Xie |

Note:

#1: The test result does not include measurement uncertainty value

3. SUMMARY

3.1. Client Information

| | |
|---------------|--|
| Applicant: | Suijimanbu (SHANGHAI) Sports Technology Co.Ltd. |
| Address: | Room 507, Zone C, No. 1188, Tianyaoqiao Road, Xuhui District, Shanghai |
| Manufacturer: | Suijimanbu (SHANGHAI) Sports Technology Co.Ltd. |
| Address: | Room 507, Zone C, No. 1188, Tianyaoqiao Road, Xuhui District, Shanghai |

3.2. Product Description

| Main unit information: | |
|-----------------------------|--|
| Product Name: | Lit Bike |
| Trade Mark: | freebeat. |
| Model No.: | Lit Bike |
| Listed Model(s): | - |
| Power supply: | DC 12.5V from adapter |
| Hardware version: | DSP215_MB_PCB_V1.2 |
| Software version: | V119 |
| Accessory unit information: | |
| Adapter information: | Model: XH1250-4000W Input: AC100-240V, 50/60Hz, 1.5A Output: 12.5Vdc, 4.0A |

3.3. Testing Laboratory Information

| | | |
|----------------------|---|----------------------|
| Laboratory Name | Shenzhen Huatongwei International Inspection Co., Ltd. | |
| Laboratory Location | 1/F, Bldg 3, Hongfa Hi-tech Industrial Park, Genyu Road, Tianliao, Gongming, Shenzhen, China | |
| Connect information: | Tel: 86-755-26715499 E-mail: cs@szhtw.com.cn http://www.szhtw.com.cn | |
| Qualifications | Type | Accreditation Number |
| | FCC | 762235 |

4. TEST CONFIGURATION

4.1. Descriptions of test mode

| Test mode | Description |
|-----------------------|--|
| Camera recording mode | Keep the EUT in Camera recording status |
| Video Playing mode | Keep the EUT in Video Playing status |
| Data exchange mode | Keep the EUT in Data exchange with PC status |

Pre-scan above all test mode, found below test mode which it was worse case mode, so only show the test data for worse case mode on the test report

| Test Item | Test mode for worse case |
|---------------------|--------------------------|
| Conducted Emissions | Video Playing |
| Radiated Emissions | Video Playing |

4.2. Configuration of Tested System

| Test mode | Configuration |
|--------------------|---|
| Data exchange mode | <pre> graph TD PC[PC] --- Printer[Printer] PC --- EUT[EUT] PC --- Monitor[Monitor] PC --- Keyboard[Keyboard] PC --- Mouse[Mouse] </pre> |
| Other modes | <pre> graph LR AC[AC Adapter] --- EUT[EUT] </pre> |

4.3. Support unit used in test configuration and system

The EUT has been associated with peripherals and configuration operated in a manner tended to maximize its emission characteristics in a typical application.

| Item | Equipment | Manufacturer | Model No. | FCC ID / FCC SDoC | Data Cable | Power Cord |
|------|-----------|--------------|------------------|----------------------|---------------------|--------------------|
| 1 | PC | DELL | OptiPlex 3020 MT | FCC SDoC | N/A | Unshielded 1.8m |
| 2 | Monitor | DELL | E1912Hf | FCC SDoC | N/A | Unshielded 1.8m |
| 3 | Keyboard | DELL | SK8115 | FCC SDoC | Unshielded, 1.5m | N/A |
| 4 | Mouse | DELL | MS111-T | FCC SDoC | Unshielded, 1.5m | N/A |
| 5 | Printer | EPSON | L101 | FCC SDoC | N/A | Unshielded 1.8m |

4.4. Environmental conditions

During the measurement the environmental conditions were within the listed ranges:

| | |
|--------------------|-------------|
| Temperature: | 15~35°C |
| Relative Humidity: | 30~60 % |
| Air Pressure: | 950~1050mba |

4.5. Statement of the measurement uncertainty

| Test Items | Measurement Uncertainty |
|--------------------|---------------------------------|
| Conducted emission | 3.25dB |
| Radiated emission | <1GHz: 4.22dB >1GHz: 5.06ppm |

This uncertainty represents an expanded uncertainty expressed at approximately the 95% confidence level using a coverage factor of k=1.96.

4.6. Equipments Used during the Test

| ● Conducted Emission | | | | | | | |
|----------------------|---------------------|--------------------|---------------|----------------|---------------|---------------------------|---------------------------|
| Used | Test Equipment | Manufacturer | Equipment No. | Model No. | Serial No. | Last Cal. Date (YY-MM-DD) | Next Cal. Date (YY-MM-DD) |
| ● | Shielded Room | Albatross projects | HTWE0114 | N/A | N/A | 2018/09/28 | 2023/09/27 |
| ● | EMI Test Receiver | R&S | HTWE0111 | ESCI | 101247 | 2022/08/30 | 2023/08/29 |
| ● | Artificial Mains | SCHWARZBECK | HTWE0113 | NNLK 8121 | 573 | 2022/08/29 | 2023/08/28 |
| ● | Pulse Limiter | R&S | HTWE0193 | ESH3-Z2 | 101447 | 2022/08/29 | 2023/08/28 |
| ● | RF Connection Cable | HUBER+SUHNER | HTWE0113-02 | ENVIROFLEX_142 | EF-NM-BNCM-2M | 2022/09/17 | 2023/09/16 |
| ● | Test Software | R&S | N/A | ES-K1 | N/A | N/A | N/A |

| ● Radiated Emission-6th test site | | | | | | | |
|-----------------------------------|-------------------------|--------------------|---------------|-------------|------------|---------------------------|---------------------------|
| Used | Test Equipment | Manufacturer | Equipment No. | Model No. | Serial No. | Last Cal. Date (YY-MM-DD) | Next Cal. Date (YY-MM-DD) |
| ● | Semi-Anechoic Chamber | Albatross projects | HTWE0127 | SAC-3m-02 | C11121 | 2018/09/30 | 2023/09/29 |
| ● | EMI Test Receiver | R&S | HTWE0099 | ESCI | 100900 | 2022/08/30 | 2023/08/29 |
| ● | Ultra-Broadband Antenna | SCHWARZBECK | HTWE0119 | VULB9163 | 546 | 2020/04/28 | 2023/04/27 |
| ● | Pre-Amplifier | SCHWARZBECK | HTWE0295 | BBV 9742 | N/A | 2021/11/05 | 2022/11/04 |
| ● | RF Connection Cable | HUBER+SUHNER | HTWE0062-01 | N/A | N/A | 2022/02/25 | 2023/02/24 |
| ● | RF Connection Cable | HUBER+SUHNER | HTWE0062-02 | SUCOFLEX104 | 501184/4 | 2022/02/25 | 2023/02/24 |
| ● | Test Software | R&S | N/A | ES-K1 | N/A | N/A | N/A |

| ● Radiated emission-7th test site | | | | | | | |
|-----------------------------------|-------------------------|--------------------|---------------|-----------|------------|---------------------------|---------------------------|
| Used | Test Equipment | Manufacturer | Equipment No. | Model No. | Serial No. | Last Cal. Date (YY-MM-DD) | Next Cal. Date (YY-MM-DD) |
| ● | Semi-Anechoic Chamber | Albatross projects | HTWE0122 | SAC-3m-01 | C11121 | 2018/09/27 | 2023/09/26 |
| ● | Spectrum Analyzer | R&S | HTWE0098 | FSP40 | 100597 | 2022/08/25 | 2023/08/24 |
| ● | Horn Antenna | SCHWARZBECK | HTWE0126 | 9120D | 1011 | 2020/04/01 | 2023/03/31 |
| ● | Broadband Pre-amplifier | SCHWARZBECK | HTWE0201 | BBV 9718 | 9718-248 | 2022/02/28 | 2023/02/27 |
| ● | RF Connection Cable | HUBER+SUHNER | HTWE0126-01 | RE-7-FH | N/A | 2022/03/04 | 2023/03/03 |
| ● | Test Software | Audix | N/A | E3 | N/A | N/A | N/A |

5. TEST CONDITIONS AND RESULTS

5.1. Conducted Emissions

LIMIT

FCC CFR Title 47 Part 15 Subpart B Section 15.107:

| Frequency range (MHz) | Limit (dBuV) | |
|-----------------------|--------------|-----------|
| | Quasi-peak | Average |
| 0.15-0.5 | 66 to 56* | 56 to 46* |
| 0.5-5 | 56 | 46 |
| 5-30 | 60 | 50 |

* Decreases with the logarithm of the frequency.

TEST CONFIGURATION

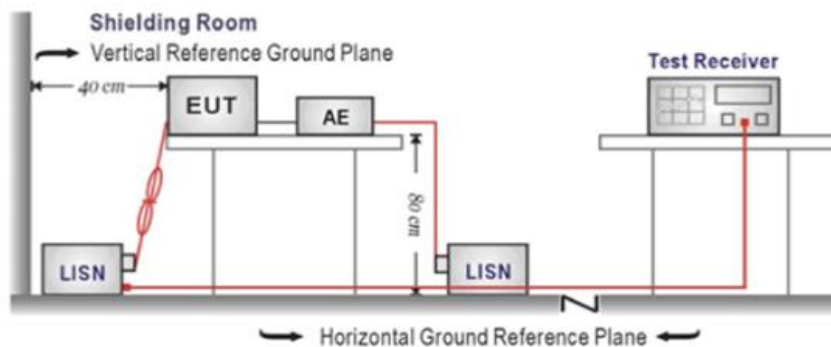

TEST PROCEDURE

1. The EUT was setup according to ANSI C63.4:2014
2. The EUT was placed on a plat form of nominal size, 1 m by 1.5 m, raised 80 cm above the conducting ground plane. The vertical conducting plane was located 40 cm to the rear of the EUT. All other surfaces of EUT were at least 80 cm from any other grounded conducting surface.
3. The EUT and simulators are connected to the main power through a line impedance stabilization network (LISN). The LISN provides a 50ohm / 50uH coupling impedance for the measuring equipment.
4. The peripheral devices are also connected to the main power through a LISN. (Please refer to the block diagram of the test setup and photographs)
5. Each current-carrying conductor of the EUT power cord, except the ground (safety) conductor, was individually connected through a LISN to the input power source.
6. The excess length of the power cord between the EUT and the LISN receptacle were folded back and forth at the center of the lead to form a bundle not exceeding 40 cm in length.
7. Conducted emissions were investigated over the frequency range from 0.15MHz to 30MHz using a receiver bandwidth of 9 kHz.
8. During the above scans, the emissions were maximized by cable manipulation.

TEST MODE:

Please refer to the clause 3.3

TEST RESULTS

Passed Not Applicable

Test Line:

L

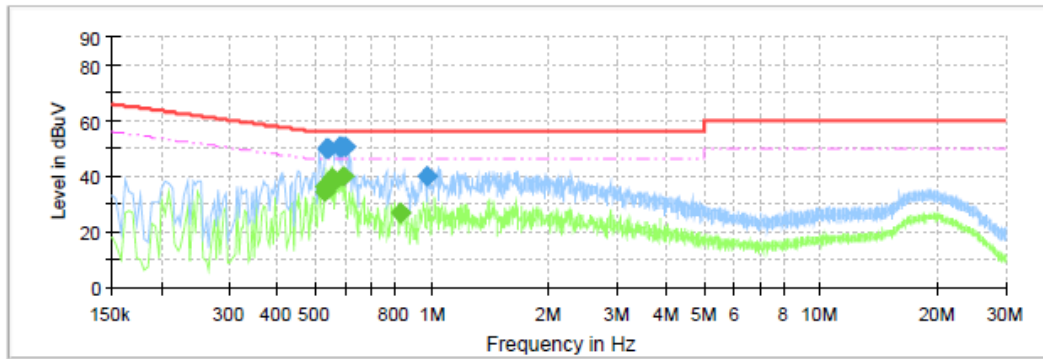

Final Result

| Frequency (MHz) | QuasiPeak (dBuV) | CAverage (dBuV) | Limit (dBuV) | Margin (dB) | Line | Corr. (dB) |
|-----------------|------------------|-----------------|--------------|-------------|------|------------|
| 0.527500 | --- | 34.39 | 46.00 | 11.61 | L1 | 10.1 |
| 0.531500 | --- | 36.32 | 46.00 | 9.68 | L1 | 10.1 |
| 0.536500 | 50.07 | --- | 56.00 | 5.93 | L1 | 10.1 |
| 0.539500 | 50.31 | --- | 56.00 | 5.69 | L1 | 10.1 |
| 0.551500 | --- | 39.55 | 46.00 | 6.45 | L1 | 10.1 |
| 0.559500 | --- | 37.87 | 46.00 | 8.13 | L1 | 10.1 |
| 0.575500 | 50.60 | --- | 56.00 | 5.40 | L1 | 10.1 |
| 0.587500 | 50.81 | --- | 56.00 | 5.19 | L1 | 10.1 |
| 0.591500 | --- | 40.30 | 46.00 | 5.70 | L1 | 10.1 |
| 0.595500 | 50.57 | --- | 56.00 | 5.43 | L1 | 10.1 |
| 0.831500 | --- | 26.68 | 46.00 | 19.32 | L1 | 10.1 |
| 0.971500 | 40.17 | --- | 56.00 | 15.83 | L1 | 10.1 |

Test Line:

N

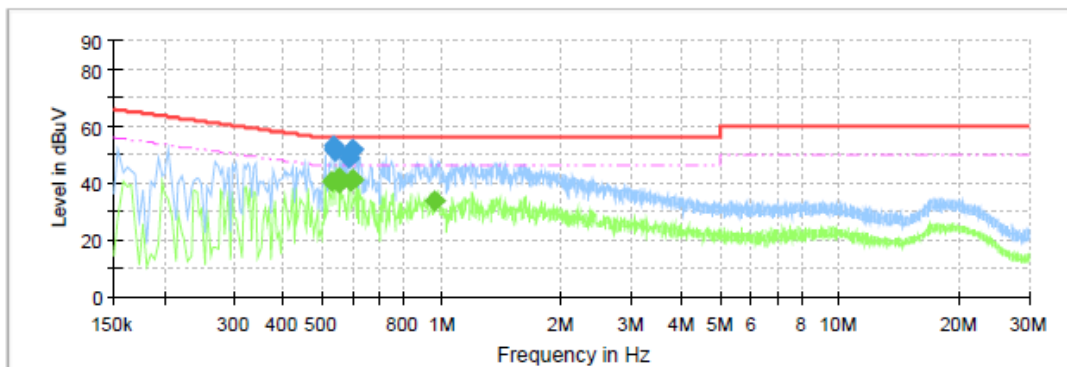

Final Result

| Frequency (MHz) | QuasiPeak (dBuV) | CAverage (dBuV) | Limit (dBuV) | Margin (dB) | Line | Corr. (dB) |
|-----------------|------------------|-----------------|--------------|-------------|------|------------|
| 0.531500 | --- | 40.65 | 46.00 | 5.35 | N | 10.1 |
| 0.532500 | 52.87 | --- | 56.00 | 3.13 | N | 10.1 |
| 0.535500 | 52.14 | --- | 56.00 | 3.86 | N | 10.1 |
| 0.539500 | 51.21 | --- | 56.00 | 4.79 | N | 10.1 |
| 0.551500 | --- | 42.04 | 46.00 | 3.96 | N | 10.1 |
| 0.555500 | --- | 39.89 | 46.00 | 6.11 | N | 10.1 |
| 0.587500 | 48.66 | --- | 56.00 | 7.34 | N | 10.1 |
| 0.591500 | --- | 40.81 | 46.00 | 5.19 | N | 10.1 |
| 0.591500 | 51.08 | --- | 56.00 | 4.92 | N | 10.1 |
| 0.595500 | 51.77 | --- | 56.00 | 4.23 | N | 10.1 |
| 0.599500 | --- | 41.32 | 46.00 | 4.68 | N | 10.1 |
| 0.959500 | --- | 33.49 | 46.00 | 12.51 | N | 10.1 |

5.2. Radiated Emissions

LIMIT

FCC CFR Title 47 Part 15 Subpart B Section 15.109

| Frequency | Limit (dBuV/m @3m) | Value |
|---------------|--------------------|------------|
| 30MHz-88MHz | 40.00 | Quasi-peak |
| 88MHz-216MHz | 43.50 | Quasi-peak |
| 216MHz-960MHz | 46.00 | Quasi-peak |
| 960MHz-1GHz | 54.00 | Quasi-peak |
| Above 1GHz | 54.00 | Average |
| | 74.00 | Peak |

TEST CONFIGURATION

➤ 30MHz ~ 1GHz

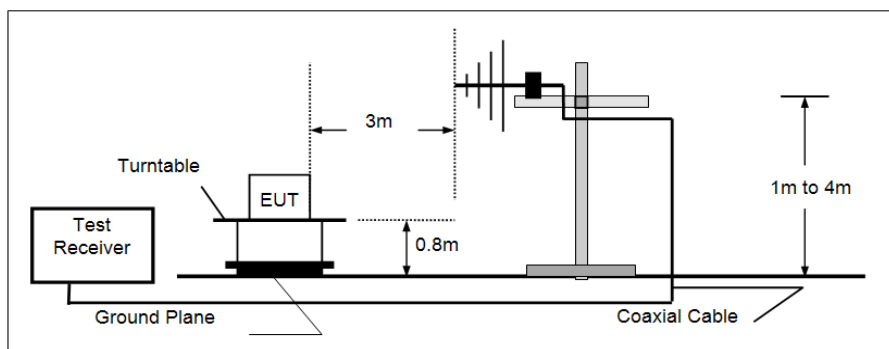

➤ Above 1GHz

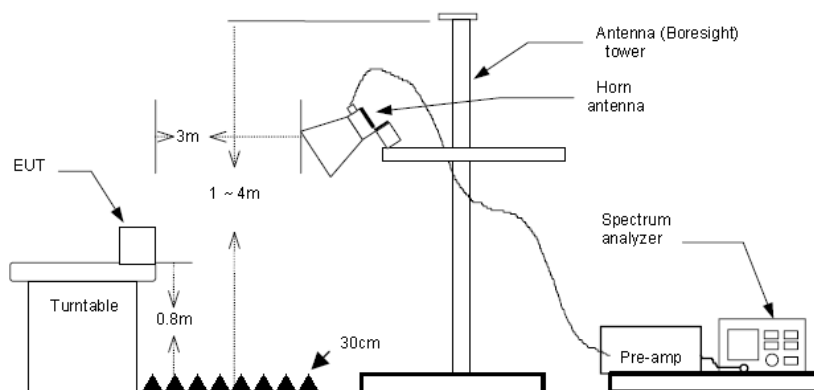

TEST PROCEDURE

- The EUT was tested according to ANSI C63.4:2014.
- The EUT is placed on a turn table which is 0.8 meter above ground.
- The turn table is rotated 360 degrees to determine the position of the maximum emission level.
- The EUT was positioned such that the distance from antenna to the EUT was 3 meters.
- The antenna is scanned from 1 meter to 4 meters to find out the maximum emission level. This is repeated for both horizontal and vertical polarization of the antenna.
- Use the following spectrum analyzer settings
 - Span shall wide enough to fully capture the emission being measured;
 - Below 1GHz,
RBW=120KHz, VBW=300KHz, Sweep=auto, Detector function=peak, Trace=max hold;
If the emission level of the EUT measured by the peak detector is 3 dB lower than the applicable limit, the peak emission level will be reported. Otherwise, the emission measurement will be repeated using the quasi-peak detector and reported.
 - From 1GHz to 5th harmonic, RBW=1MHz, VBW=3MHz

TEST MODE:

Please refer to the clause 3.3

TEST RESULTS

Passed **Not Applicable**

Note: Final Level = Receiver Read level + Antenna Factor + Cable Loss – Preamplifier Factor
The emission levels of frequency above 6GHz are very lower than limit and not show in test report.

Polarization:

Horizontal

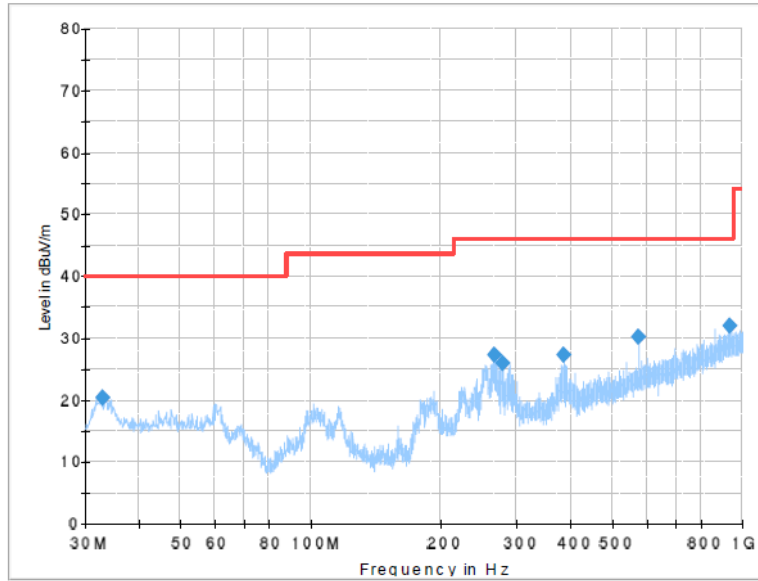

Final Result

| Frequency (MHz) | MaxPeak (dBuV/m) | Limit (dBuV/m) | Margin (dB) | Height (cm) | Pol | Azimuth (deg) | Corr. (dB/m) |
|-----------------|------------------|----------------|-------------|-------------|-----|---------------|--------------|
| 32.910000 | 20.24 | 40.00 | 19.76 | 100.0 | H | 141.0 | -11.8 |
| 266.801250 | 27.20 | 46.00 | 18.80 | 100.0 | H | 274.0 | -8.6 |
| 278.683750 | 25.87 | 46.00 | 20.13 | 100.0 | H | 259.0 | -8.2 |
| 386.960000 | 27.22 | 46.00 | 18.78 | 100.0 | H | 283.0 | -4.8 |
| 573.685000 | 30.15 | 46.00 | 15.85 | 300.0 | H | 207.0 | 0.1 |
| 933.918750 | 32.02 | 46.00 | 13.98 | 300.0 | H | 276.0 | 7.0 |

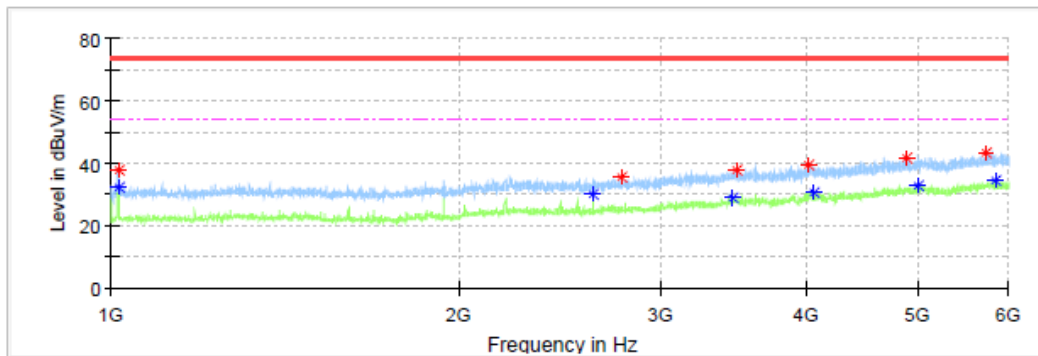

Critical Freqs

| Frequency (MHz) | MaxPeak (dBuV/m) | Average (dBuV/m) | Limit (dBuV/m) | Margin (dB) | Height (cm) | Pol | Azimuth (deg) | Corr. (dB/m) |
|-----------------|------------------|------------------|----------------|-------------|-------------|-----|---------------|--------------|
| 4072.500000 | --- | 30.47 | 54.00 | 23.53 | 150.0 | H | 0.0 | -1.5 |
| 4899.375000 | 41.57 | --- | 74.00 | 32.43 | 150.0 | H | 0.0 | 2.6 |
| 1014.375000 | 37.59 | --- | 74.00 | 36.41 | 150.0 | H | 80.0 | -9.9 |
| 5740.625000 | 43.29 | --- | 74.00 | 30.71 | 150.0 | H | 150.0 | 4.8 |
| 3464.375000 | --- | 29.16 | 54.00 | 24.84 | 150.0 | H | 164.0 | -3.7 |
| 4998.750000 | --- | 32.76 | 54.00 | 21.24 | 150.0 | H | 221.0 | 2.9 |
| 4026.250000 | 39.50 | --- | 74.00 | 34.50 | 150.0 | H | 263.0 | -1.6 |
| 3488.750000 | 37.64 | --- | 74.00 | 36.36 | 150.0 | H | 277.0 | -3.6 |
| 2618.750000 | --- | 30.18 | 54.00 | 23.82 | 150.0 | H | 296.0 | -6.4 |
| 5849.375000 | --- | 34.21 | 54.00 | 19.79 | 150.0 | H | 296.0 | 5.2 |
| 1013.750000 | --- | 32.33 | 54.00 | 21.67 | 150.0 | H | 310.0 | -9.9 |
| 2770.625000 | 35.70 | --- | 74.00 | 38.30 | 150.0 | H | 310.0 | -5.8 |

Polarization:

Vertical

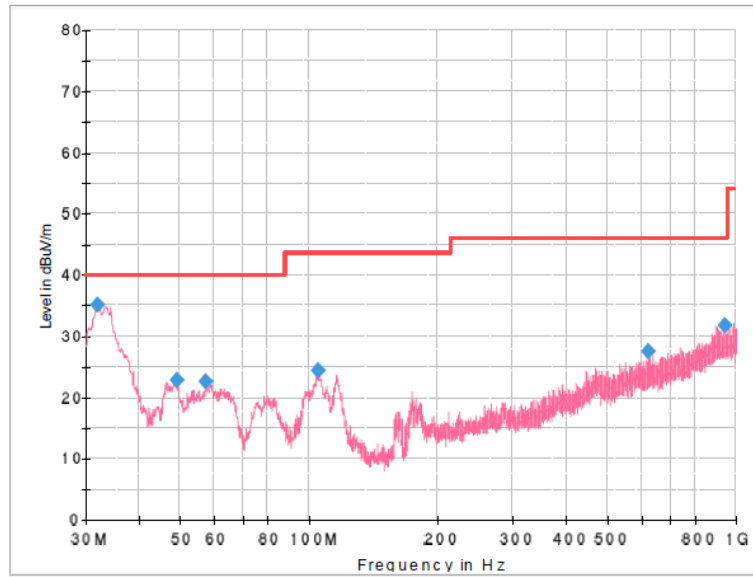

Final Result

| Frequency (MHz) | MaxPeak (dBuV/m) | Limit (dBuV/m) | Margin (dB) | Height (cm) | Pol | Azimuth (deg) | Corr. (dB/m) |
|-----------------|------------------|----------------|-------------|-------------|-----|---------------|--------------|
| 32.061250 | 35.08 | 40.00 | 4.92 | 100.0 | V | 86.0 | -12.0 |
| 49.278750 | 22.84 | 40.00 | 17.16 | 100.0 | V | 38.0 | -9.1 |
| 57.402500 | 22.62 | 40.00 | 17.38 | 100.0 | V | 38.0 | -9.8 |
| 105.417500 | 24.26 | 43.50 | 19.24 | 100.0 | V | 126.0 | -11.4 |
| 622.427500 | 27.53 | 46.00 | 18.47 | 100.0 | V | 0.0 | 1.1 |
| 940.830000 | 31.83 | 46.00 | 14.17 | 100.0 | V | 195.0 | 7.1 |

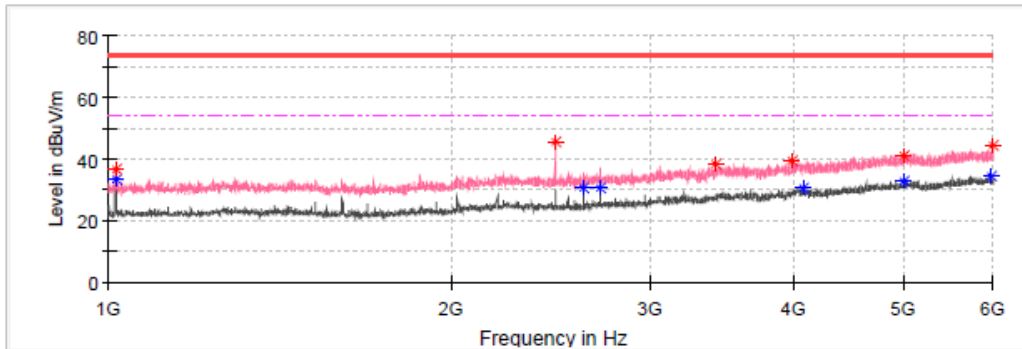

Critical Freqs

| Frequency (MHz) | MaxPeak (dBuV/m) | Average (dBuV/m) | Limit (dBuV/m) | Margin (dB) | Height (cm) | Pol | Azimuth (deg) | Corr. (dB/m) |
|-----------------|------------------|------------------|----------------|-------------|-------------|-----|---------------|--------------|
| 5007.500000 | --- | 32.87 | 54.00 | 21.13 | 150.0 | V | 20.0 | 2.9 |
| 2703.125000 | --- | 30.54 | 54.00 | 23.46 | 150.0 | V | 35.0 | -5.9 |
| 5986.875000 | --- | 34.46 | 54.00 | 19.54 | 150.0 | V | 35.0 | 5.5 |
| 4080.000000 | --- | 30.47 | 54.00 | 23.53 | 150.0 | V | 49.0 | -1.5 |
| 5015.000000 | 41.24 | --- | 74.00 | 32.76 | 150.0 | V | 65.0 | 3.0 |
| 5990.625000 | 44.22 | --- | 74.00 | 29.78 | 150.0 | V | 65.0 | 5.5 |
| 2468.750000 | 45.51 | --- | 74.00 | 28.49 | 150.0 | V | 134.0 | -6.8 |
| 1013.750000 | --- | 33.29 | 54.00 | 20.71 | 150.0 | V | 153.0 | -9.9 |
| 1013.750000 | 36.70 | --- | 74.00 | 37.30 | 150.0 | V | 153.0 | -9.9 |
| 3425.625000 | 38.27 | --- | 74.00 | 35.73 | 150.0 | V | 181.0 | -4.1 |
| 2619.375000 | --- | 30.33 | 54.00 | 23.67 | 150.0 | V | 195.0 | -6.4 |
| 3989.375000 | 39.33 | --- | 74.00 | 34.67 | 150.0 | V | 195.0 | -1.8 |

6. TEST SETUP PHOTOS

Conducted Emissions (AC Mains)



Radiated Emissions (30MHz-1GHz)



Radiated Emissions (Above 1GHz)

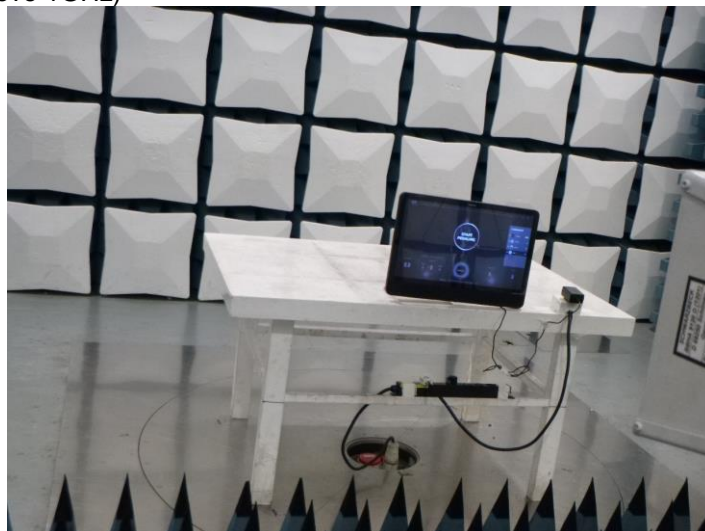

7. EXTERNAL AND INTERNAL PHOTOS

Refer to the test report No.: CHTEW22090138

-----End of Report-----