

Boom Bike

Basic

USER
MANUAL



freeteat.

FREEBEAT PHILOSOPHY

AUTHENTICITY

Ride with Authenticity

With every rhythm of the pedal, we score combos to the beat. The gamification system allows us to nurture deep bonds while connecting and competing with our friends and family. Our mind is free, connect with your true self, your best self. We believe in the power of sharing, therefore making freebeat products affordable and feasible for all. We laugh, we sweat, we grow - we ride together.

SOPHISTICATION

Ride with Sophistication

Every drop of sweat counts. freebeat's sensors never miss a single rotation. Whenever you feel the vibe and give an extra push, our system records your performance and recommends the best training program to suit your needs. freebeat knows what you like, and our smart class recommendations will be your new favorite.

EXCITEMENT

Ride with Excitement

freebeat creates an alternative to the dull fitness routines that burden us. We have built a fun interactive game that brings studio cycling and strength training to the comfort of your home. Distinct computer-generated special effects are tailored to the rhythm to make each course unique and flow perfectly to the vibe. Our gamification eliminates the boredom of riding a stationary bike.

SAFETY INSTRUCTIONS
IMPORTANT INFORMATION
SPECIFICATIONS
PACKING LIST
ASSEMBLY
GETTING STARTED
APP UI
MAINTENANCE & CARE
WARRANTY INFORMATION

CONTENTS

SAFETY INSTRUCTIONS

WARNING

Please read the instructions below carefully before assembling or using this bike. This contains important information for the use and maintenance of the equipment as well as for your personal safety. Keep this guide in a safe place for maintenance purposes or for ordering spare parts.

Consult your doctor before starting your exercise program to ensure that you are fit enough to use this equipment. Take your exercise program as a basis for advice from your doctor. Incorrect or excessive exercise can be harmful to your health.

The equipment should only be used for the intended purpose, i.e. for physical activity by adults. Any other use of the equipment is prohibited and can be dangerous.

The manufacturer cannot be held liable for damages or injuries caused by improper use of the equipment.

Incorrect repairs and structural modifications (e.g. removal or replacement of original parts) may endanger the safety of the user.

Damaged components can jeopardize your safety or reduce the lifetime of the equipment. Therefore, incorrect or damaged parts should be replaced immediately and the equipment taken out of use until then. Use only original spare parts.

For regular use, carefully inspect all components every 1-2 months. Pay close attention to the tightness of bolts and nuts. This is especially true for all connected parts.

To ensure that the safety level is maintained at the highest possible level determined by its design, this product should be serviced regularly (once a year) by certified dealers.

Before using this equipment, please check the flywheel in case of a sudden injury.

Inform the users of the equipment, especially children, about possible sources of danger during the workout.

Any interference with parts of the product that are not described in the operating instructions may cause damage or endanger the person using the machine. Extensive repairs may only be carried out by certified dealers or qualified personnel trained by the manufacturer.

If there are any problems, please consult customerservice@freebeatfit.com.

FCC CAUTION

Any changes or modifications not expressly approved by the party responsible for compliance could void the user's authority to operate the equipment.

This device complies with part 15 of the FCC Rules. Operation is subject to the following two conditions: (1) This device may not cause harmful interference, and (2) this device must accept any interference received, including interference that may cause undesired operation.

FCC RF Radiation Exposure Statement:

1. This transmitter must not be co-located or operating in conjunction with any other antenna or transmitter.

2. This equipment complies with RF

radiation exposure limits set forth for an uncontrolled environment.

3. This equipment should be installed and operated with minimum distance 20cm between the radiator & your body.

User manuals for licence-exempt radio apparatus shall contain the following or equivalent notice in a conspicuous location in the user manual or alternatively on the device or both.

This device complies with Industry Canada licence-exempt RSS standard(s). Operation is subject to the following two conditions:

- (1) this device may not cause interference, and
- (2) this device must accept any interference, including interference that may cause undesired operation of the device.

Le présent appareil est conforme aux CNR d'Industrie Canada applicables aux appareils radio exempts de licence. L'exploitation est autorisée aux deux conditions suivantes :

- (1) l'appareil ne doit pas produire de brouillage, et
- (2) l'utilisateur de l'appareil doit accepter tout brouillage radioélectrique subi, même si le brouillage est susceptible d'en compromettre le fonctionnement.

IC SAR WARNING:

This equipment should be installed and operated with minimum distance 20 cm between the radiator and your body.

Lors de l'installation et de l'exploitation de ce dispositif, la distance entre le radiateur et le corps est d'au moins 20 cm.

IMPORTANT INFORMATION

Before using the equipment for exercise, check carefully to ensure that it has been correctly assembled.

- Before using the equipment for exercise, please read the manual carefully and familiarize yourself with all the functions of the equipment.
- Initiate the child safety lock by pushing down on the resistance knob. The knob will remain in place and the bike will be locked in place until the child safety lock is released.
- This machine is designed for adults, and children should not be allowed to play with it. Children playing can behave unpredictably and dangerously, for which the manufacturer cannot be held liable.
- The maximum payload is 136 kg. It is not recommended that two or more people train on the machine at the same time.
- The flywheel is designed to be bi-directional. It cannot change direction suddenly, please come to a complete stop before changing directions.
- A slight noise on the belt or motor is due to the construction and has no negative effects on the operation.
- Always check all screws and connectors and the respective safety precautions before use.

- Do not use corrosive or abrasive materials to clean the equipment. Make sure that these materials do not pollute the environment.
- The saddle and handlebars are designed for easy adjustment, so please make sure the minimum insert depth is 55mm and securely tightened.
- To avoid injuries in the event of emergencies, always make sure that you have enough space behind your exercise bike (min. 2000 mm x 1000 mm).
- Make sure that there are no others in the area of your exercise bike, as they may be injured.
- Always wear appropriate shoes and clothing when using the equipment. Do not wear loose clothing to avoid getting into the exercise bike. Barefoot, high-heeled shoes, and leather shoes are not permitted during the workout. If your foot slips off the pedal, please place your foot on the ground or back on the pedal.
- The resistance is adjusted by the applied force between the brake sheet and flywheel. You can rotate the brake knob clockwise/counter-clockwise to adjust.

Professional Installation

- Handle all packaging materials carefully to avoid any possible hazards. Children playing with plastic bags may be at risk of suffocation.

- The equipment must be properly installed by an adult. If in doubt and help is needed, look for someone with technical skills.
- Please install the equipment carefully and pay attention to your safety to avoid injuries caused by careless mishandling of tools.

Correct Order

- Open all individual parts and place them on the floor in order. To avoid scratches on the floor, place them on cardboard boxes.
- For technical reasons, we reserve the right to perform the preliminary installation work. (E.g., install the plug.)
- Fix all parts with screws but do not lock them first. Then check if they are properly installed and lock the screws completely with a wrench. Finally, check that there are no missing parts or screws.

Packaging Disposal

- Please be sure to keep the packing for the event of repairs/warranty matters.
- At the end of the product's life cycle, it cannot be treated as ordinary household waste but must be transported to a recycling site. Please contact your local municipal administration for a place to dispose of the product.

SPECIFICATIONS



- 1. Mobile devices holder
- 2. Handlebars
- 3. Handlebar Adjustment Pin
- 4. Main Frame
- 5. Flywheel

- 6. Transport Wheels
- 7. Front Stabilizer
- 8. Handlebar Screw Cover
- 9. Emergency Brake & Gearshift

- 10. Child Safety Lock
- 11. Auto Resistance Knob
- 12. Pedals L/R
- 13. Saddle

- 14. Dumbbell Rack
- 15. Seat Depth Adjustment Pin
- 16. Rear Stabilizer
- 17. LED Lights

DEVICE INFORMATION

Bluetooth: 5.0
Voltage: 12V=2A
Maximum operating ambient temperature: 25.0°C

USER REQUIREMENT

Height range: 5' - 6'4"
Weight maximum: 300lbs
Minimum age: 14+

APP DOWNLOAD AND INSTALLATION

1. Scan the below QR code using your device.
2. Click install to download our App.
3. Click the download package to install it.



LED LIGHTS

Control the LED Lights via the settings in the APP. The lights will automatically adjust according to the BPM of your cycling class.

SYSTEM SUPPORT

Android version 7.0 or later
iOS version 14.0 or later
iPadOS version 14.0 or later

NOTE

Note: This equipment has been tested and found to comply with the limits for a Class B digital device, pursuant to part 15 of the FCC Rules. These limits are designed to provide reasonable protection against harmful interference in a residential installation. This equipment generates, uses and can radiate radio frequency energy and, if not installed and used in accordance with the instructions, may cause harmful interference to radio communications. However, there is no guarantee that interference will not occur in a particular installation. If this equipment does cause harmful interference to radio or television reception, which can be determined by turning the equipment off and on, the user is encouraged to try to correct the interference by one or more of the following measures:

- Reorient or relocate the receiving antenna.
- Increase the separation between the equipment and receiver.
- Connect the equipment into an outlet on a circuit different from that to which the receiver is connected.
- Consult the dealer or an experienced radio/TV technician for help.

The Boom Bike's design, features, UI interface, and specifications are subject to change with new software updates or alterations. No notice will be given for minor design or product changes.

PACKING LIST

A. MAIN FRAME (β LINE PRE-ATTACHED)

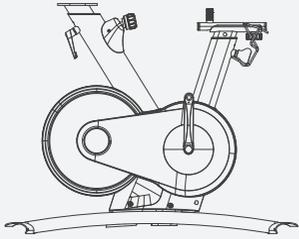

B. FRONT STABILIZER

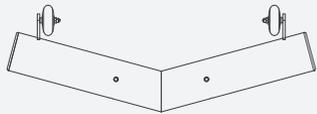

C. REAR STABILIZER



D. HANDLEBARS

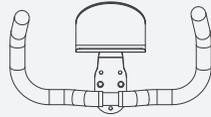

E. LEFT PEDAL

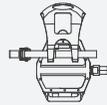

F. RIGHT PEDAL

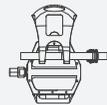

G. SADDLE (α LINE PRE-ATTACHED)



H. HANDLEBAR SCREW COVER



I. POWER ADAPTER



J. TOOL KIT

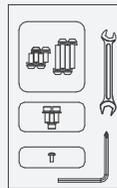

⚠ WARNING

Turn the box over and empty the bike pieces out. Handle with care since the box's contents may be stuck within the box.

Locate the instruction manual placed between the bike and the monitor.

Remove all the bike's parts before assembly. Only remove screws when necessary (step-by-step) as shown in the directions to reduce confusion.

Tighten screws with your hands or a screwdriver. When tightening, do not overtighten or force the screws into place.

TOOL KIT

J1.
SCREWS
M8 × 20MM
x4

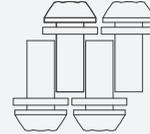

J3.
SCREWS
M8 × 16mm
x3

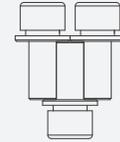

J4.
SCREW
M6 × 12MM
x1



J5.

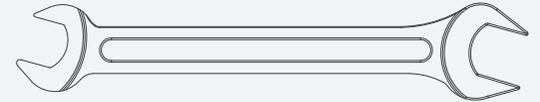

J6.

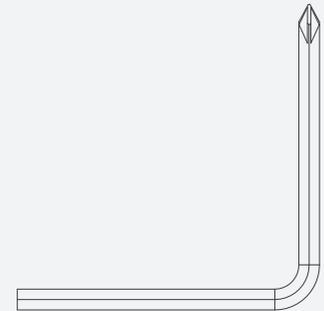

ASSEMBLY

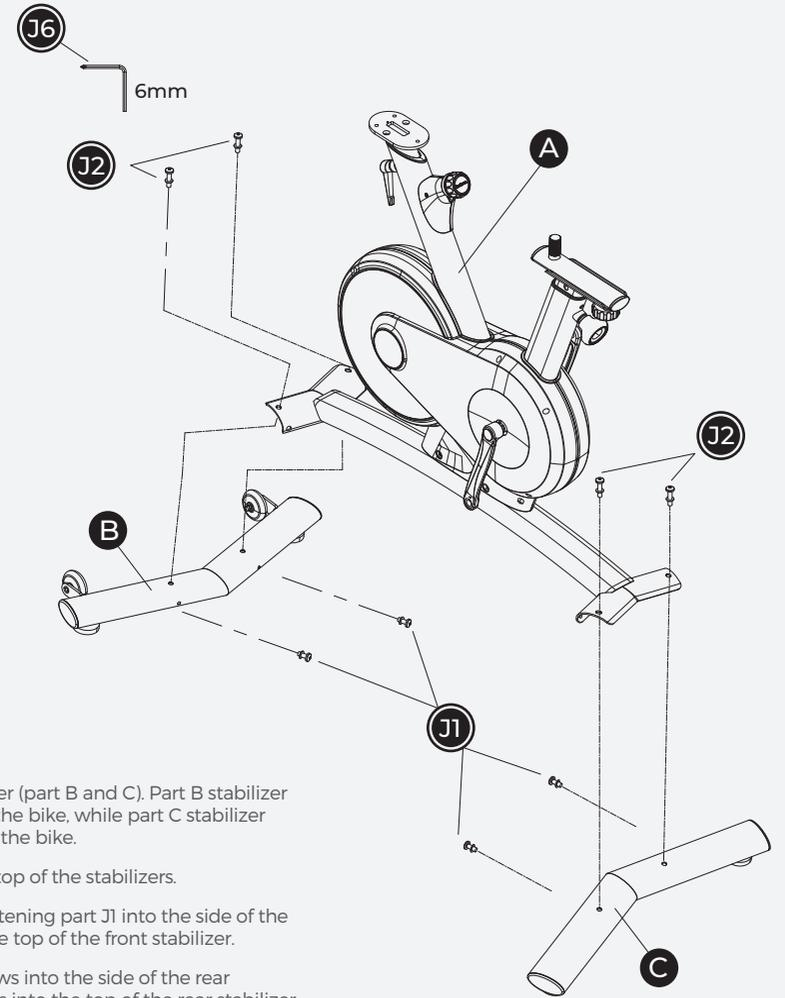
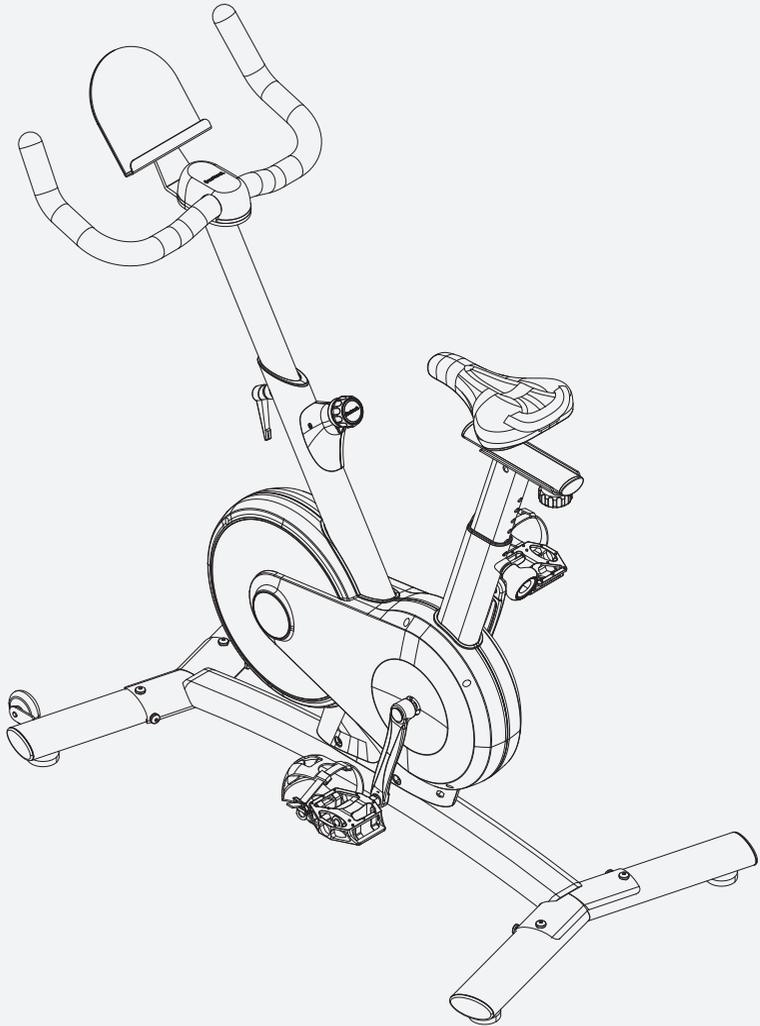

STEP 1

Acquire the front and rear stabilizer (part B and C). Part B stabilizer (with wheels) goes in the front of the bike, while part C stabilizer (without wheels) fits at the rear of the bike.

Place the main frame (part A) on top of the stabilizers.

Fix the main frame in place by fastening part J1 into the side of the front stabilizer, and part J2 into the top of the front stabilizer.

Then fasten the remaining J1 screws into the side of the rear stabilizer, and remaining J2 screws into the top of the rear stabilizer.

* Use foam from the packaging to give extra support to hold the bike upright, if needed.

* It's suggested to attach the front stabilizer first, then attach the rear stabilizer.

STEP 2

Fit the handlebars (part D) on the frame and screw in the screws (part J3), make sure the holes and screws are aligned.

Put the screw cover (part H) on the handle platform to cover the screws. Push it down when you match the position and holes.

* To remove the screw cover, first remove the screw on the cover to release the bolt.

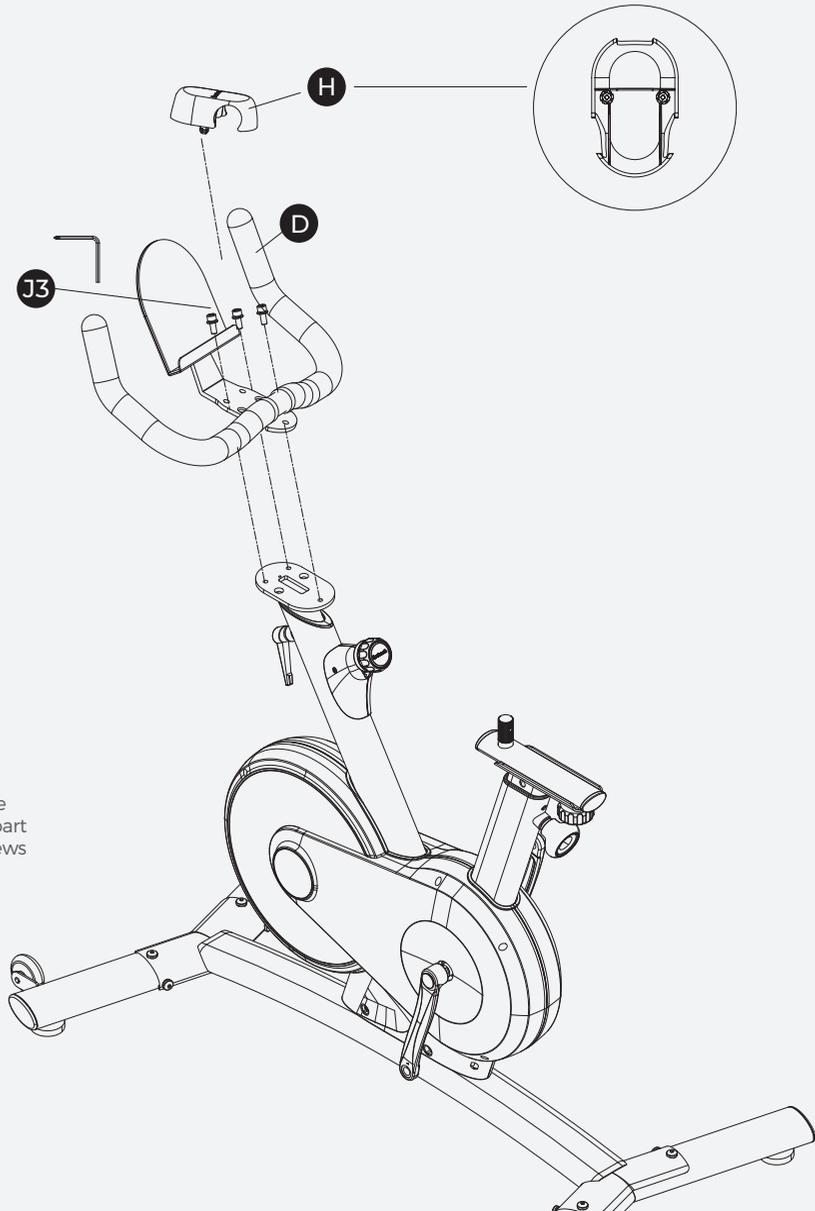

STEP 3

Find the left and right pedals (part E & F). Look for either an L or R symbol on the crank and axle to distinguish between left and right respectively.

Twist the pedals into their respective sides of the bike. The left pedal turns counterclockwise, and the right clockwise. Tighten with hand first, then use a 15mm wrench.

* Please test ride the bike slowly after assembly and tighten the pedals accordingly to ensure safety.

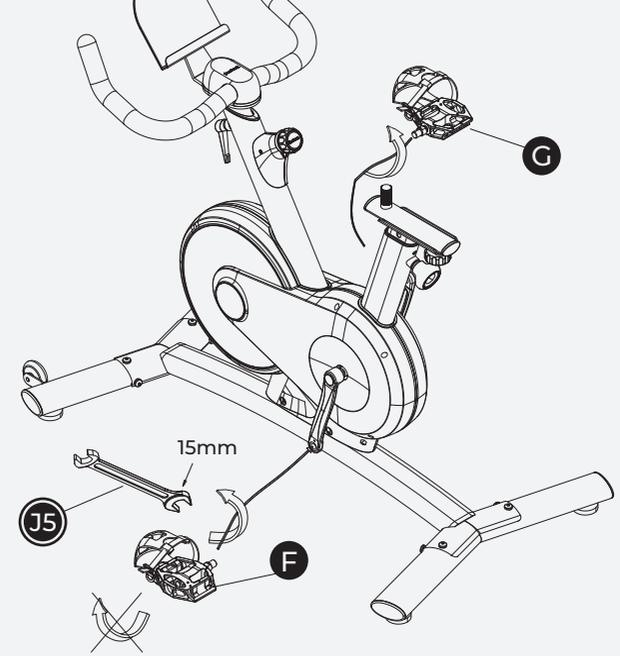

STEP 4

Remove the saddle (part G) and install it onto the bike. Ensure the saddle is pushed all the way to the bottom of the frame. Screw and secure screws J4 through the middle of the saddle. Use a 13mm wrench to tighten the seat-fixing nuts firmly on both sides of the saddle.

Connect the beta cable (on part A) and alpha cable (on part G). Carefully position the metal pins inside. Once connected, spin the silver metal cover to lock the cables in place.

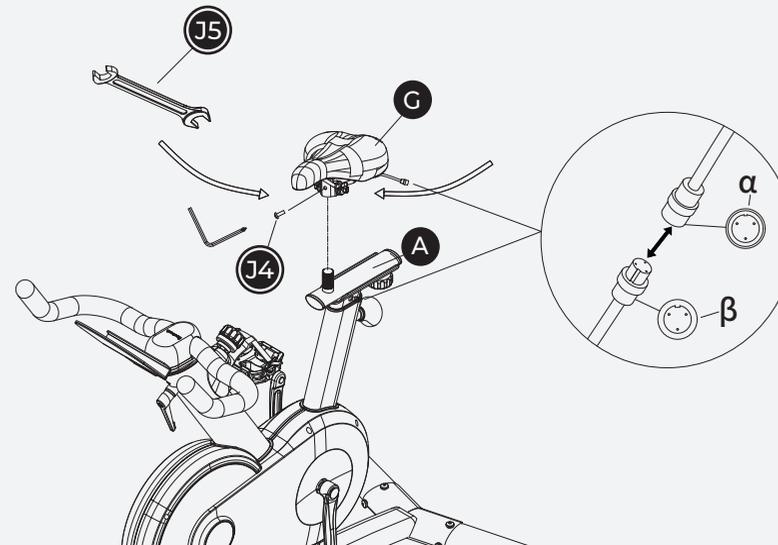

⚠ CAUTION

It is important to use the original power supply that came with the bike. Using an unauthorized power supply may negatively impact its performance and even lead to serious consequences.

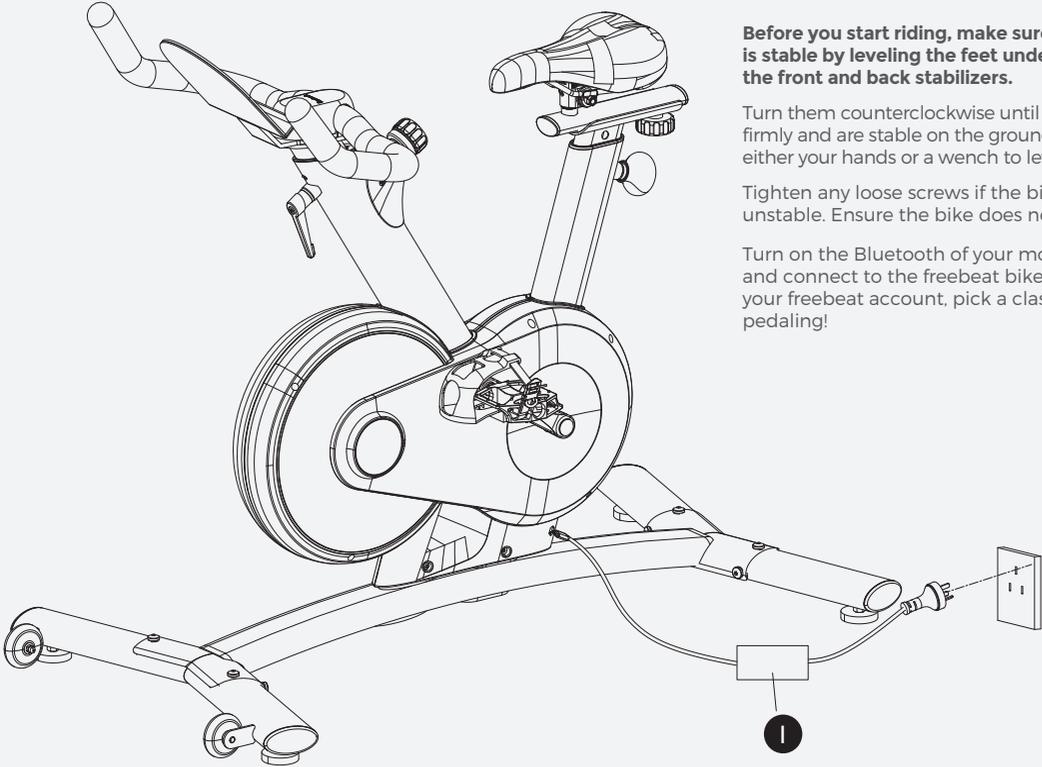

STEP 5

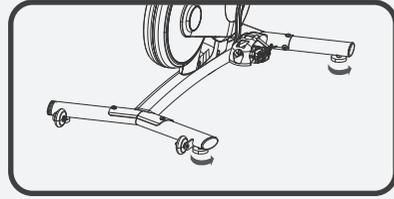

Before you start riding, make sure the bike is stable by leveling the feet underneath the front and back stabilizers.

Turn them counterclockwise until they rest firmly and are stable on the ground. Use either your hands or a wrench to level the feet.

Tighten any loose screws if the bike is still unstable. Ensure the bike does not wobble.

Turn on the Bluetooth of your mobile device and connect to the freebeat bike. Log in to your freebeat account, pick a class and start pedaling!

GETTING STARTED

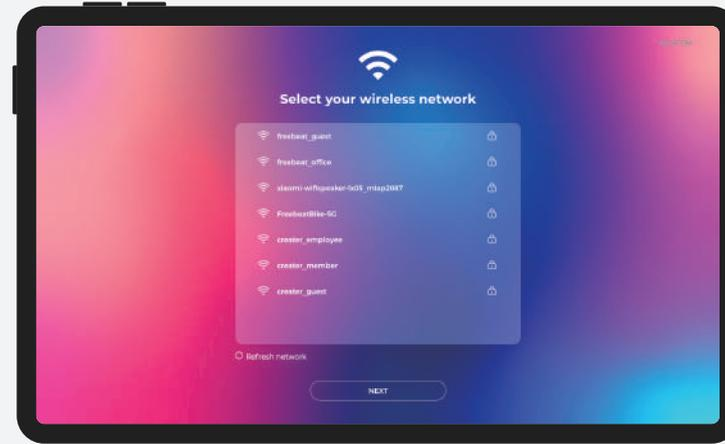

STEP 1

CONNECT TO WIFI

Search and select your preferred WiFi network

- * If the network is secured, you will be prompted to enter a password. Enter the password and tap "Connect".
- * If the network is not secured, the bike will connect to the network.

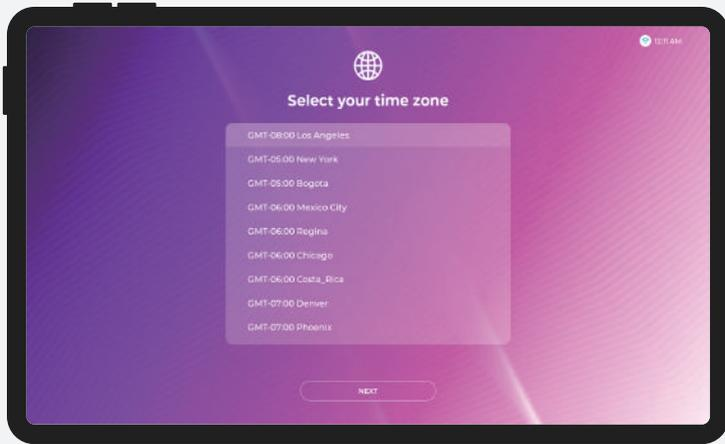

STEP 2

SELECT TIME ZONE

Choose your current location and select the time zone. Tap "NEXT".

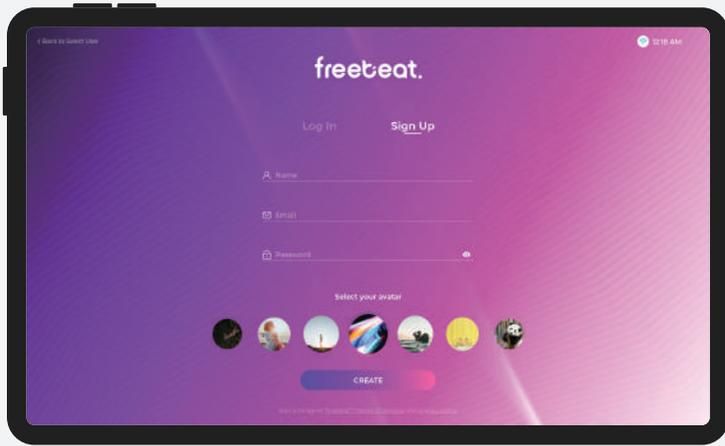

STEP 3

CREATE YOUR ACCOUNT

Enter your name, email, and password, then select an avatar. Tap "CREATE".

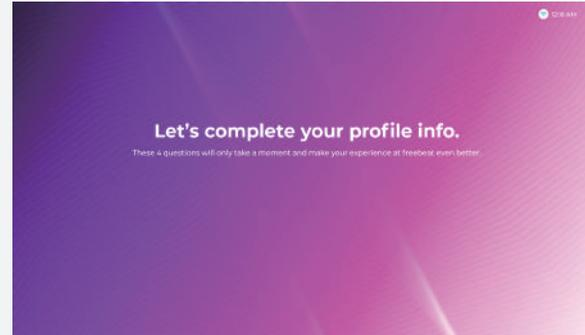

STEP 3.1 PERSONALIZE YOUR ACCOUNT
Complete your personal information (four basic questions). You can skip this step and complete it later.

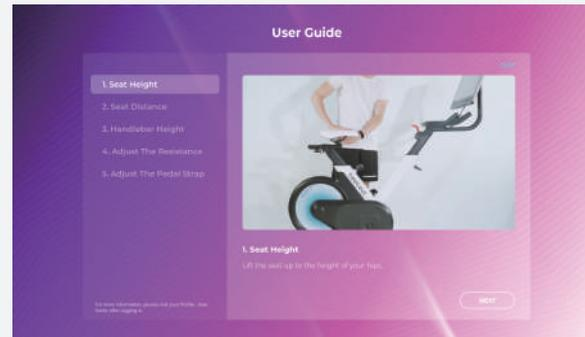

STEP 3.2 ADJUST YOUR BIKE
Follow the steps on the screen and adjust the bike to fit your body. Ensure you maintain a proper body position while riding to avoid any injuries or strains.

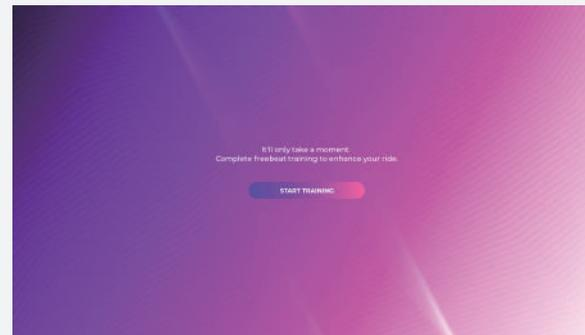

STEP 3.3 FREEBEAT TRAINING DAY
You're nearly there! Join our "freebeat training day" to learn more about the system and how to get the most out of your workout.

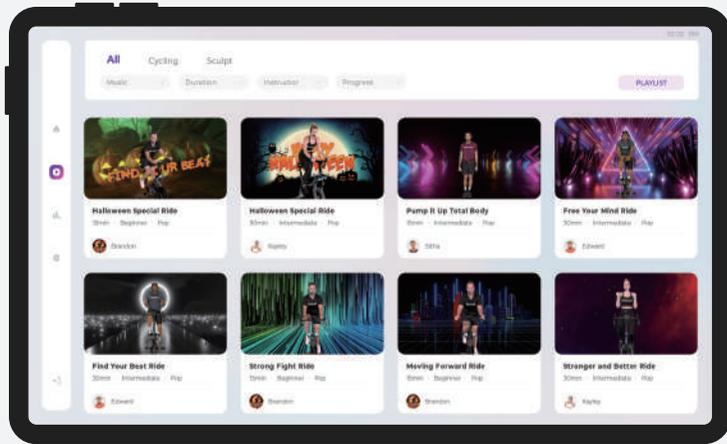

STEP 4

PERSONALIZED HOME SCREEN

Everyone's home screen is different. We personalize your home screen based on what the system thinks will suit you best. The more classes you take, the more the algorithm will understand your habits. You can use filters and the search bar to find specific classes and trainers.

APP UI DESCRIPTION

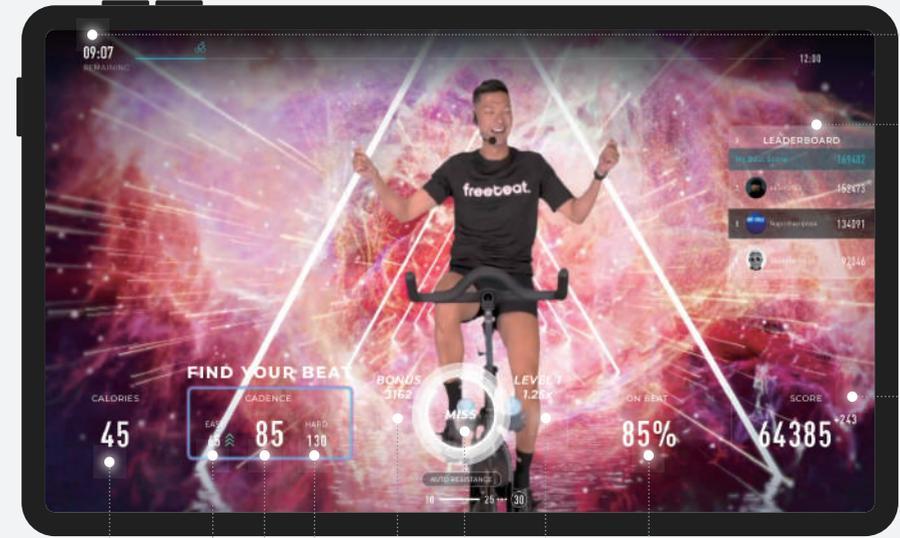

TIME REMAINING

LEADERBOARD

SCORE

% ON BEAT

LEVEL

COMBO

BONUS SCORE

DOUBLE BEAT

CADENCE

SINGLE BEAT

CALORIES

MAINTENANCE & CARE

RECOMMENDED BODY POSITION

Your hands should rest comfortably on the handlebars without having to reach and should bend slightly at the elbows. Your legs should be slightly bent at the bottom of your pedal stroke.

Adjust accordingly if not as described.

EVERY 3 TO 5 RIDES

Adjust the saddle to ensure it is parallel to the ground. Use the 13mm wrench to tighten the seat-fixing nuts on both sides.

AFTER RIDE CARE

To ensure safe operation and optimal performance, check for wear and tear by performing maintenance on a regular basis. Replace any damaged or defective parts immediately. Do not use the bike until the repair is completely fixed. Only use original parts from the manufacturer. Changes or modifications to the bike not approved by freebeat could void the warranty.

CLEANING: Wipe down your bike after each ride with a damp cloth.

LEVELING FEET: If the bike is unstable and rocks back and forth, turn each leveling knob under the stabilizers until the bike rests evenly on the ground.

EVERY 4 TO 6 RIDES

CLEANING: Clean the bike thoroughly using a damp cloth and a mild household cleaner (diluted with water).

PEDALS: Tighten any loose pedals with the included wrench. Pedals should be tightened to 25 lb-ft of torque. Turn clockwise to tighten the right pedal, and counterclockwise to tighten the left pedal.

EVERY 15 TO 20 RIDES

CAUTION: Service other than the procedures described here must be performed by an authorized technician.

EMERGENCY BRAKE: Test the emergency brake by pressing down on the resistance knob while pedaling slowly. The flywheel should come to a complete stop immediately. If it does not, stop using the bike and contact freebeat support.

FRAME: Check the entire frame for signs of wear and tear. Tighten any loose screws and bolts.

ANNUAL MAINTENANCE

PEDALS: Replace pedals if necessary. Tighten new pedals to 25 lb-ft of torque. For further instructions, visit www.freebeatfit.com

WARRANTY INFORMATION

If you have a problem with a bike purchased from www.freebeatfit.com, please contact us directly at customerservice@freebeatfit.com.

STOCHASTIC TECHNOLOGY LLC. ("freebeat™") extends the following Limited Warranty, which only applies to non-commercial, in-home, and indoor use of our products. Any other use of our products shall void this Limited Warranty. During the applicable Limited Warranty periods described below, the covered components of products will be free of defects or malfunctions during normal use. Certain exclusions apply, as further described in this Limited Warranty. The Limited Warranty applies for the following components of products only, for the time period indicated. The Limited Warranty applies only against defects discovered within the applicable Limited Warranty period and only so long as our products remain in the possession of the original purchaser, or, for a gifted freebeat™ bike, the owner of the original membership attached to our products.

FRAME: 10 YEARS

freebeat™ warrants the frame (excluding any moving parts attached to the structural frame) against defects in workmanship and materials for a period of ten years from the date of original delivery.

BIKE COMPONENTS: 24 MONTHS

freebeat™ warrants the components and all original parts of the freebeat™ bike against defects in workmanship and materials for a period of 24 months from the date of original delivery.

⚠ FCC CAUTION

Any changes or modifications not expressly approved by the party responsible for compliance could void the user's authority to operate the equipment.

This device complies with part 15 of the FCC Rules. Operation is subject to the following two conditions: (1) This device may not cause harmful interference, and (2) this device must accept any interference received, including interference that may cause undesired operation.

FCC RF Radiation Exposure Statement:

1. This transmitter must not be co-located or operating in conjunction with any other antenna or transmitter.
2. This equipment complies with RF radiation exposure limits set forth for an uncontrolled environment.
3. This equipment should be installed and operated with minimum distance 20cm between the radiator & your body.

freebeat.

www.freebeatfit.com