



# TEST REPORT

**Test Report No.:** UL-RPT-RP-13831825-716-3-FCC

**Applicant** : InFarm Indoor Urban Farming GmbH  
**Model No.** : Infarm Gateway  
**FCC ID** : Contains 2A2CI-INF001-WF and Contains 2A2CI-INF001-CL  
**Technology** : Intermodulations WLAN 5 GHz (802.11 a, n) & UMTS Band V (850 MHz)  
Intermodulations WLAN 5 GHz (802.11 a, n) & LTE B5 (850 MHz)  
**Test Standard(s)** : FCC Parts 15.207, 15.209(a), 15.407 & 22.917

For details of applied tests refer to test result summary

1. This test report shall not be reproduced in full or partial, without the written approval of UL International Germany GmbH.
2. The results in this report apply only to the sample tested.
3. The test results in this report are traceable to the national or international standards.
4. **Test Report Version 1.1 supersede Version 1.0 with immediate effect**  
Test Report No. UL-RPT-RP-13831825-716-3-FCC Version 1.1, Issue Date 08 APRIL 2022 replaces  
Test Report No. UL-RPT-RP-13831825-716-3-FCC Version 1.0, Issue Date 31 MARCH 2022, which is no longer valid.
5. Result of the tested sample: **PASS**

Prepared by: Sercan, Usta  
Title: Laboratory Engineer  
Date: 08 April 2022

Approved by: Ajit, Phadtare  
Title: Lead Test Engineer  
Date: 08 April 2022



Deutsche  
Akkreditierungsstelle  
D-PL-19381-02-00

This laboratory is accredited by DAkkS.  
The tests reported herein have been performed in  
accordance with its' terms of accreditation.

This page has been left intentionally blank.

## **Table of Contents**

<b>1. Customer Information.....</b>	<b>4</b>
1.1. Applicant Information	4
1.2. <b>Manufacturer Information</b>	4
<b>2. Summary of Testing.....</b>	<b>5</b>
2.1. General Information	5
Applied Standards	5
Location	5
Date information	5
2.2. Summary of Test Results	6
2.3. Methods and Procedures	6
2.4. Deviations from the Test Specification	6
<b>3. Equipment Under Test (EUT) .....</b>	<b>7</b>
3.1. Identification of Equipment Under Test (EUT)	7
3.2. Description of EUT	7
3.3. Modifications Incorporated in the EUT	7
3.4. Additional Information Related to Testing	8
3.5. Support Equipment	9
A. Support Equipment (In-house)	9
B. Support Equipment (Manufacturer supplied)	9
<b>4. Operation and Monitoring of the EUT during Testing .....</b>	<b>10</b>
4.1. Operating Modes / Worst-case Identification	10
4.2. Configuration and Peripherals	11
<b>5. Measurements, Examinations and Derived Results .....</b>	<b>12</b>
5.1. General Comments	12
5.2. Test Results	13
5.2.1. Transmitter AC Conducted Spurious Emissions	13
5.2.2. Transmitter Out of Band Radiated Emissions	19
<b>6. Measurement Uncertainty .....</b>	<b>33</b>
<b>7. Used equipment .....</b>	<b>34</b>
<b>8. Report Revision History .....</b>	<b>35</b>

## **1. Customer Information**

### **1.1. Applicant Information**

<b>Company Name:</b>	InFarm Indoor Urban Farming GmbH
<b>Company Address:</b>	Colditzstr. 30 12099 Berlin, Germany
<b>Company Phone No.:</b>	+49 (0) 30991916590
<b>Company E-Mail:</b>	info@infarm.com
<b>Contact Person:</b>	Ibrahim Oguz Yildirim
<b>Contact E-Mail Address:</b>	ibrahimoguz.yildirim@infarm.com
<b>Contact Phone No.:</b>	+49 (0) 30991916590

### **1.2. Manufacturer Information**

<b>Company Name:</b>	InFarm Indoor Urban Farming GmbH
<b>Company Address:</b>	Colditzstr. 30 12099 Berlin, Germany
<b>Company Phone No.:</b>	+49 (0) 30991916590
<b>Company E-Mail:</b>	info@infarm.com
<b>Contact Person:</b>	Ibrahim Oguz Yildirim
<b>Contact E-Mail Address:</b>	ibrahimoguz.yildirim@infarm.com
<b>Contact Phone No.:</b>	+49 (0) 30991916590

## **2.Summary of Testing**

### **2.1. General Information**

#### **Applied Standards**

<b>Specification Reference:</b>	47CFR15.407 and 47CFR15.403
<b>Specification Title:</b>	Code of Federal Regulations Volume 47 (Telecommunications): Part 15 Subpart E (Unlicensed National Information Infrastructure Devices) – Sections 15.403 and 15.407
<b>Specification Reference:</b>	47CFR15.207 and 47CFR15.209
<b>Specification Title:</b>	Code of Federal Regulations Volume 47 (Telecommunications): Part 15 Subpart C (Intentional Radiators) - Sections 15.207 and 15.209
<b>Specification Reference:</b>	47CFR22.917
<b>Specification Title:</b>	Code of Federal Regulations Volume 47 (Telecommunications): Part 22 Subpart H (Cellular Radiotelephone Service) – Section 22.917

#### **Location**

<b>Location of Testing:</b>	UL International Germany GmbH Hedelfinger Str. 61 70327 Stuttgart Germany
<b>Test Firm Registration:</b>	399704

#### **Date information**

<b>Order Date:</b>	17 May 2020
<b>EUT arrived:</b>	11 August 2021
<b>Test Dates:</b>	29 December 2021 to 23 March 2022
<b>EUT returned:</b>	-/-

## 2.2. Summary of Test Results

Clause	Measurement	Complied	Did not comply	Not performed	Not applicable
Part 15.207	Transmitter AC Conducted Emissions	<input checked="" type="checkbox"/>	<input type="checkbox"/>	<input type="checkbox"/>	<input type="checkbox"/>
Part 15.407(b) / 15.209(a) Part 2.1053 / 22.917(a)	Transmitter Out of Band Radiated Emissions <sup>(1)</sup>	<input checked="" type="checkbox"/>	<input type="checkbox"/>	<input type="checkbox"/>	<input type="checkbox"/>

### Note(s):

- As per applicant's declaration, the EUT is a host product integrating FCC pre-certified radio transmitter
  - BT-LE module (FCC ID: Contains 2A2CI-INF001-WF)
  - Cellular module (FCC ID: Contains 2A2CI-INF001-CL).

Therefore, only partial testing is performed. More info regarding the test modes which tested can be found in section 3.4

## 2.3. Methods and Procedures

<b>Reference:</b>	ANSI C63.10-2013
<b>Title:</b>	American National Standard of Procedures for Compliance Testing of Unlicensed Wireless Devices
<b>Reference:</b>	FCC KDB 789033 D02 General U-NII Test Procedures New Rules v02r01 December 14, 2017
<b>Title:</b>	Guidelines for Compliance Testing of Unlicensed National Information Infrastructure (U-NII) Devices – Part 15, Subpart E
<b>Reference:</b>	ANSI C63.26-2015
<b>Title:</b>	American National Standard for Compliance Testing of Transmitters
<b>Reference:</b>	FCC KDB 174176 D01 Line Conducted FAQ v01r01 June 3, 2015
<b>Title:</b>	AC Power-Line Conducted Emissions Frequently Asked Questions

## 2.4. Deviations from the Test Specification

For the measurements contained within this test report, there were no deviations from, additions to, or exclusions from the test specification identified above.

### **3. Equipment Under Test (EUT)**

#### **3.1. Identification of Equipment Under Test (EUT)**

<b>Brand Name:</b>	Infarm
<b>Model Name or Number:</b>	Infarm Gateway
<b>Test Sample Serial Number:</b>	100101000221 (RF Test Sample with External SMA Connectors)
<b>Hardware Version Number:</b>	1.1.0
<b>Firmware Version Number:</b>	W15.68.19.p48-15.26.19.p48
<b>FCC ID:</b>	Contains 2A2CI-INF001-WF and Contains 2A2CI-INF001-CL

<b>Brand Name:</b>	MobileMark
<b>Model:</b>	SMW-414 multiband, 4-cable Global Cellular/LTE, WiFi & GPS
<b>Test Sample Serial Number:</b>	N/A
<b>Additional Info:</b>	External Antenna (Acre)

#### **3.2. Description of EUT**

The equipment under test was a host product supporting Bluetooth Low Energy (BLE), WiFi 2.4 GHz operations in 2.4 - 2.4835 GHz ISM band, WiFi 5 GHz operations in U-N-II bands and Cellular operations in UMTS Band 2 & 5, LTE Band 2, 4, 5, 7& 12 bands.

#### **3.3. Modifications Incorporated in the EUT**

Following modifications were applied to the EUT during testing.

- In order to avoid unwanted emissions from EUT as part of EUT filtering two ferrites (Manufacturer: Würth Elektronik | Type: 742 717 33 | Passthrough) was placed just outside the EUT's enclosure and near AC/DC power supply on the DC power supply cable.

**Therefore, manufacturer must include these additional ferrites on the AC/DC power supply cable; to ensure compliant results.**

**3.4. Additional Information Related to Testing**

<b>Type of Radio Device:</b>	Transceiver		
<b>Power Supply Requirement(s):</b>	Nominal	6 - 24 (V) DC (Used voltage 12 V DC)	
<b>Temperature Requirement(s):</b>	Nominal	25°C	
	Minimum	-25°C	
	Maximum	70°C	
<b>Relative Humidity</b>	30%		
<b>Antenna Type:</b>	Multiband External Antenna		
<b>Antenna Details:</b>	4-Cable Multiband  SMW-414 multiband  MobileMark I SMA Connector   Cable 1 Cellular   Cable 2 BLE		
<b>Antenna Gain:</b>	Cellular 3 dBi   DTS 5 dBi		
<b>Technology Tested: WLAN 5 GHz</b>			
<b>FCC Equipment Classification:</b>	Digital Transmission System (DTS)		
<b>Supported Transmit Operating Mode(s):</b>	802.11b/g/n HT20 <sup>(Note 1)</sup>		
<b>Worst Case Data Rates:</b>	802.11a	6 Mbps <sup>(Note 1)</sup>	
<b>Worst Case Modulation Types:</b>	BPSK, QPSK, 16QAM & 64QAM		
<b>Nominal Channel Bandwidth:</b>	20 MHz		
<b>Transmit Frequency Range:</b>	5150 MHz to 5725 MHz		
<b>Transmit Channels Tested:</b>	<b>Channel ID</b>	<b>Channel Number</b>	<b>Channel Frequency (MHz)</b>
	Bottom	36	5180
<b>Tested Technology: UMTS Band V (850 MHz)</b>			
<b>FCC Equipment Classification:</b>	Public Mobile Service		
<b>Mode:</b>	UMTS		
<b>Modulation Type:</b>	WCDMA		
<b>Operating Frequency Range:</b>	UMTS Band V: 824 to 849 MHz (Uplink)		
<b>Transmit Channels Tested: GSM 850</b>	Channel ID	Channel Number	Channel Frequency (MHz)
	Middle	4183	836.6
<b>Tested Technology: LTE 850</b>			
<b>FCC Equipment Classification:</b>	Public Mobile Service		
<b>Operating Frequency Range:</b>	LTE B5: 824-849 MHz (Uplink)		
<b>Mode:</b>	LTE B5		
<b>Modulation Type:</b>	1.4 MHz - %50 RB - 16 QAM		
<b>Transmit Channels Tested: LTE 850</b>	Channel ID	Channel Frequency (MHz)	
	Bottom	824.7	



<b>Highest Frequency Generated or Used in the EUT or on which the EUT operates or tunes</b>	5290 MHz (oscillator freq. for RF application) 1200 MHz (oscillator freq. for internal functionality e.g. bus/ CPU clock etc)		
<b>Scope of Partial Host Product Testing:</b>	FCC KDB 996369 D04 Section 3.0		
<b>Has modular transmitter been fully tested by the module grantee on the required number of channels, modulation types, and modes?</b>	<input checked="" type="checkbox"/> Yes	<input type="checkbox"/> No	<input type="checkbox"/> Not Known
<b>Are emissions occurring due to the intermixing of emissions with the other transmitters, digital circuitry, or due to physical properties of the host product (enclosure) checked &amp; measured?</b>	<input checked="" type="checkbox"/> Yes	<input type="checkbox"/> No	<input type="checkbox"/> Not Stated
<b>Frequency Range of Radiated Measurements:</b>	FCC Part 15.33(a)(1): intentional radiator operates below 10 GHz: to the 10 <sup>th</sup> harmonic of the highest fundamental frequency or to 40 GHz, whichever is lower.		
As per applicant's declaration, the EUT is a host product integrating FCC pre-certified radio transmitter <ul style="list-style-type: none"> <li>• BT-LE module (FCC ID: Contains 2A2CI-INF001-WF)</li> <li>• Cellular module (FCC ID: Contains 2A2CI-INF001-CL).</li> </ul>			
<i>(Note 3)</i> In accordance with FCC KDB 996369 D04 Section 3.4 (b) the Host Product testing has been performed on unwanted (spurious) radiated emissions on the worst-case modulation and channel per frequency range as shown in original filing			

**3.5. Support Equipment**

The following support equipment was used to exercise the EUT during testing:

**A. Support Equipment (In-house)**

Item	Description	Brand Name	Model Name or Number	Serial Number
1	Laptop (labtool v2.0.0.93 software installed)	HP	Probook 650 G1	5CG6143YWB
2	Ethernet Cable (2m)	N/A	N/A	N/A

**B. Support Equipment (Manufacturer supplied)**

Item	Description	Brand Name	Model Name or Number	Serial Number
1	AC/DC Power Supply	Phoenix Contact	UNO-PS/1AC/12DC/100W	290299702051P1207 2020/12/17V

## **4. Operation and Monitoring of the EUT during Testing**

### **4.1. Operating Modes / Worst-case Identification**

The EUT was tested in the following operating mode(s):

WLAN 5 GHz Test Mode: Continuously transmitting modulated carrier with combination of

- UNII-1
- Data Rate: 6 Mbps <sup>(Note 1)</sup> <sup>(Note 2)</sup>
- Modulation: 64 QAM
- Power Settings<sup>12</sup> <sup>(Note 1)</sup> <sup>(Note 2)</sup>

UMTS Band V Mode

- Established link with base station simulator in UMTS mode<sup>(Note 2)</sup>
- Max. Power

LTE B5 Mode

- Established link with base station simulator in LTE mode<sup>(Note 2)</sup>
- Max. Power

<sup>(Note 1)</sup> In accordance with FCC KDB 996369 D04 Section 3.4 (b) the Host Product testing has been performed on unwanted (spurious) radiated emissions on the worst-case modulation and channel per frequency range as shown in original filing

<sup>(Note 2)</sup> As per applicant's declaration, the EUT is a host product integrating FCC pre-certified radio transmitter

- BT-LE module (FCC ID: Contains 2A2CI-INF001-WF)
- Cellular module (FCC ID: Contains 2A2CI-INF001-CL).

## **4.2. Configuration and Peripherals**

The EUT was tested in the following configuration(s):

- The applicant supplied documents containing the setup instructions and commands “Setting up direct test mode (DTM) on the balenaFin.pdf” and “Labtool commands guide.pdf”

### **EUT Power Supply:**

- The EUT was powered by 12 V DC power supply via AC/DC adapter.

### **Test Mode Activation:**

#### **Bluetooth:**

- The test modes were activated using labtool v2.0.0.93 software which supplied by customer.
- EUT were configured to transmit test modes continuously with maximum power level.

#### **Cellular:**

- Rohde & Schwarz CMW 500 Universal Radio Communications Tester was used to activate the cellular test modes in EUT.
- The equipment under test (EUT) was configured to measure its highest possible emission level with maximum signal level in uplink with power control settings (TPC).
- The connection stability & quality of service was monitored throughout the tests.

#### **Radiated Measurements:**

- In accordance with ANSI C63.26, the EUT allows for the connection of external accessories, including external electrical control signals; hence EUT has been tested with the listed equipment under section 3.5 B which form part of a system. Therefore, were used for radiated spurious emission, measurements.
- Before starting final radiated spurious emission measurements “worst case verification” with the EUT in Standing-position & Laying-position and different positions of the antenna was performed by Lab.
- The EUT in Standing-position was found to be the worst case therefore this report includes relevant results.
- Antenna’s 3 input cables connected to EUT directly. 1 GPS port terminated with 50 Ohm termination.
- The radiated spurious emissions below 30 MHz were performed with the EUT positioned on the turn table and rotating 360 degrees while the loop antenna height was set to 80 cm.
- Radiated spurious emissions were performed with the EUT positioned on the turn table and rotating 360 degrees while the antenna height varies from 1 to 4 m over the measurement frequency range.
- R&S® EMC32 V10.60.10 Software was used for the Radiated spurious emission measurements.

## **5. Measurements, Examinations and Derived Results**

### **5.1. General Comments**

Measurement uncertainties are evaluated in accordance with current best practice. Our reported expanded uncertainties are based on standard uncertainties, which are multiplied by an appropriate coverage factor to provide a statistical confidence level of approximately 95%. Please refer to Section 6 *Measurement Uncertainty* for details.

In accordance with DAkkS requirements all the measurement equipment is on a calibration schedule. All equipment was within the calibration period on the date of testing.

## 5.2. Test Results

### 5.2.1. Transmitter AC Conducted Spurious Emissions

#### Test Summary:

Test Engineer:	Sercan Usta	Test Dates:	23 March 2022
Test Sample Serial Number:	100101000221(RF Test Sample with External SMA Connectors)		
Test Site Identification	SR 7/8		

FCC Reference:	Part 15.207
Test Method Used:	ANSI C63.10 Section 6.2 / FCC KDB 174176 and notes below

#### Environmental Conditions:

Temperature (°C):	25
Relative Humidity (%):	39

#### Settings of the Instrument

Detector	Quasi Peak/ Average Peak
----------	--------------------------

#### Note(s):

- Measurements were performed in shielded room (SR7/ 8 Asset Number 1603671). The EUT was placed at a height of 10 cm above the reference ground plane and in a distance of 40 cm from the vertical ground plane at the edge of the table.
- Measurement software used: Toyo EMI Software; CE measurement software EP5/CE Ver 4.0.1.
- The EUT was plugged into an AC/DC Power Supply. The Power Supply was connected to 120 VAC / 60 Hz and 240 VAC / 60 Hz single phase supply via a LISN.
- In accordance with FCC KDB 174176 Q4, tests were performed with a 240 VAC 60 Hz single phase supply as this was within the voltage range marked on the 100-240 VAC~50/60 Hz power supply.
- The EUT was configured to transmit simultaneously on both technologies:
  - WLAN 5 GHz Test mode: UNII-1 | 802.11a | 20 MHz | PWR 12 | Bottom Channel
  - LTE B5 Test mode: a communication link with Base station (CMW 500) | Bottom channel
- All other emissions shown on the pre-scan plot were investigated. Only the highest 6 emissions have been reported in the tables below in accordance with ANSI C63.10 section 6.2.5.
- The final measured value, for the given emission, in the table below incorporates the cable loss. Calculation: Level = test receiver reading + path loss (cable attenuation + correction LISN).

**Transmitter AC Conducted Spurious Emissions (continued)**

**Test setup:**

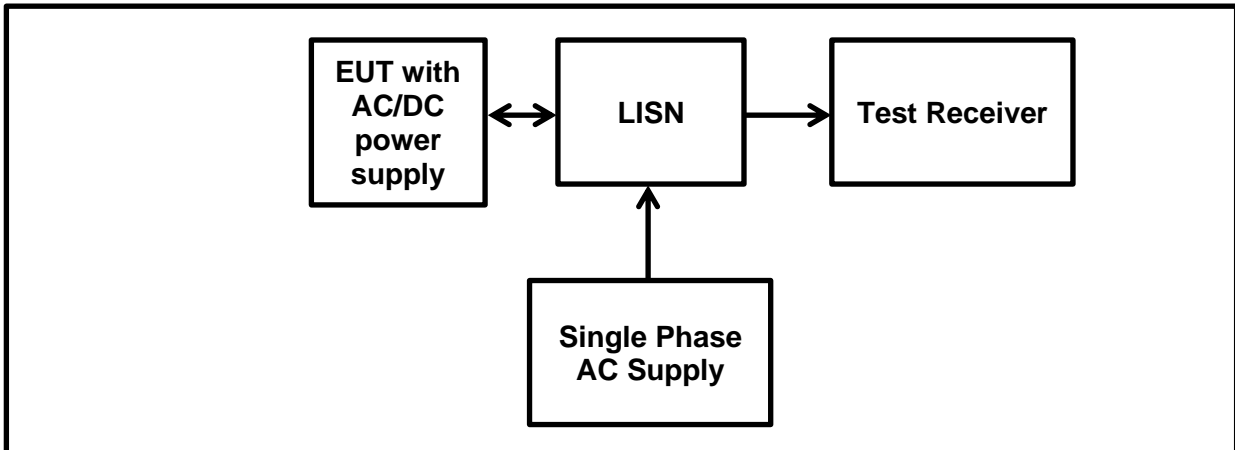

**Transmitter AC Conducted Spurious Emissions (continued)****Results: WLAN 5 GHz Mode/ UNII-1 / 802.11a / 20 MHz / PWR 12 / Bottom Channel / 6 Mbps + LTE /B5/Bottom Channel****Results: 120 VAC 60 Hz / Live / Quasi Peak**

Frequency (MHz)	Line	Level (dB $\mu$ V)	Limit (dB $\mu$ V)	Margin (dB)	Result
0.34931	Live	43.00	59.00	16.00	Complied
4.23788	Live	26.80	56.00	29.20	Complied
5.97897	Live	32.60	60.00	27.40	Complied
8.98450	Live	42.80	60.00	17.20	Complied
9.96431	Live	40.50	60.00	19.50	Complied
11.95964	Live	44.90	60.00	15.10	Complied

**Results: 120 VAC 60 Hz / Live / Average**

Frequency (MHz)	Line	Level (dB $\mu$ V)	Limit (dB $\mu$ V)	Margin (dB)	Result
0.34931	Live	42.80	49.00	6.20	Complied
4.23788	Live	21.10	46.00	24.90	Complied
5.97897	Live	30.50	50.00	19.50	Complied
8.98450	Live	34.00	50.00	16.00	Complied
9.96431	Live	48.00	50.00	2.00	Complied
11.95964	Live	39.80	50.00	10.20	Complied

**Results: 120 VAC 60 Hz / Neutral / Quasi Peak**

Frequency (MHz)	Line	Level (dB $\mu$ V)	Limit (dB $\mu$ V)	Margin (dB)	Result
0.35004	Neutral	43.40	59.00	15.60	Complied
4.24721	Neutral	27.20	56.00	28.80	Complied
5.98066	Neutral	36.80	60.00	23.20	Complied
8.98532	Neutral	44.00	60.00	16.00	Complied
9.96729	Neutral	50.90	60.00	9.10	Complied
11.95992	Neutral	44.00	60.00	16.00	Complied

**Transmitter AC Conducted Spurious Emissions (continued)**

**Results: WLAN 5 GHz Mode/ UNII-1 / 802.11a / 20 MHz / PWR 12 / Bottom Channel / 6 Mbps + LTE /B5/Bottom Channel**

**Results: 120 VAC 60 Hz / Neutral / Average**

Frequency (MHz)	Line	Level (dBµV)	Limit (dBµV)	Margin (dB)	Result
0.35004	Neutral	41.50	49.00	7.50	Complied
4.24721	Neutral	21.70	46.00	24.30	Complied
5.98066	Neutral	19.10	50.00	30.90	Complied
8.98532	Neutral	36.80	50.00	13.20	Complied
9.96729	Neutral	43.40	50.00	6.60	Complied
11.95992	Neutral	36.60	50.00	13.40	Complied

**Result: Pass**

**Plot: 120 VAC 60 Hz / Live and Neutral Line**

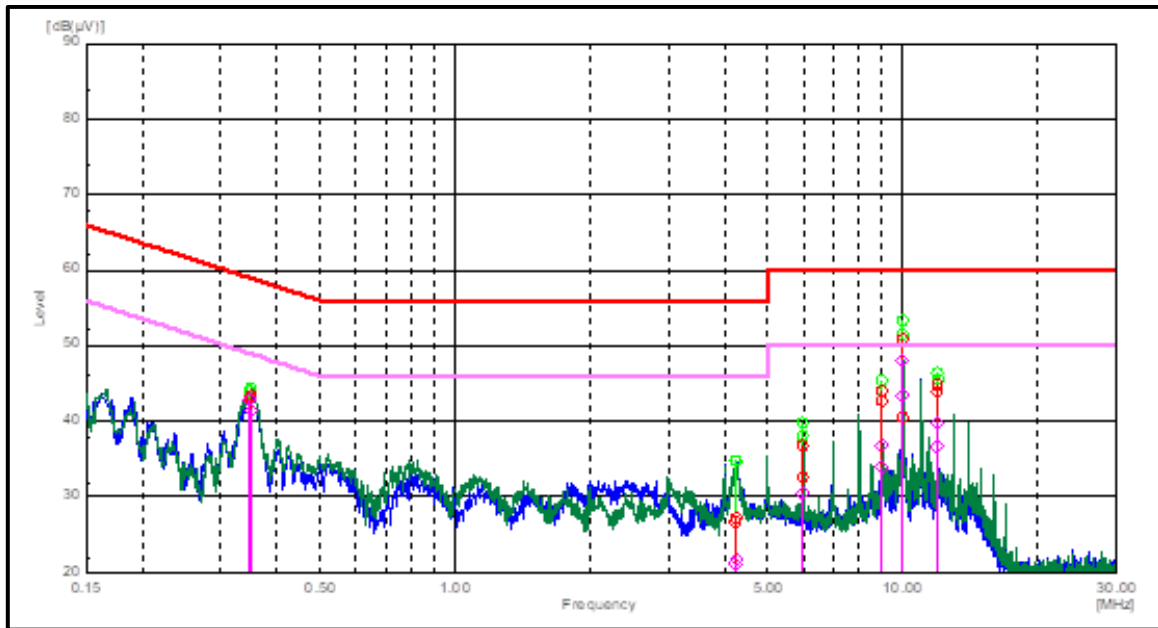

*Note: These plots are pre-scans and for indication purposes only. For final measurements, see accompanying tables.*



**Transmitter AC Conducted Spurious Emissions (continued)****Results: WLAN 5 GHz Mode/ UNII-1 / 802.11a / 20 MHz / PWR 12 / Bottom Channel / 6 Mbps + LTE /B5/Bottom Channel****Results: 240 VAC 60 Hz / Live / Quasi Peak**

Frequency (MHz)	Line	Level (dB $\mu$ V)	Limit (dB $\mu$ V)	Margin (dB)	Result
0.34972	Live	47.70	59.00	11.30	Complied
4.99294	Live	33.70	56.00	22.30	Complied
8.98937	Live	40.30	60.00	19.70	Complied
9.98704	Live	47.90	60.00	12.10	Complied
11.97958	Live	40.60	60.00	19.40	Complied
13.97871	Live	29.70	60.00	30.30	Complied

**Results: 240 VAC 60 Hz / Live / Average**

Frequency (MHz)	Line	Level (dB $\mu$ V)	Limit (dB $\mu$ V)	Margin (dB)	Result
0.34972	Live	45.60	49.00	3.40	Complied
4.99294	Live	25.40	46.00	20.60	Complied
8.98937	Live	26.70	50.00	23.30	Complied
9.98704	Live	33.50	50.00	16.50	Complied
11.97958	Live	28.80	50.00	21.20	Complied
13.97871	Live	23.40	50.00	26.60	Complied

**Results: 240 VAC 60 Hz / Neutral / Quasi Peak**

Frequency (MHz)	Line	Level (dB $\mu$ V)	Limit (dB $\mu$ V)	Margin (dB)	Result
0.34976	Neutral	47.00	59.00	12.00	Complied
4.26187	Neutral	28.80	56.00	27.20	Complied
5.99146	Neutral	34.40	60.00	25.60	Complied
8.99217	Neutral	36.40	60.00	23.60	Complied
9.96864	Neutral	47.20	60.00	12.80	Complied
10.98399	Neutral	43.00	60.00	17.00	Complied

**Transmitter AC Conducted Spurious Emissions (continued)**

**Results: WLAN 5 GHz Mode/ UNII-1 / 802.11a / 20 MHz / PWR 12 / Bottom Channel / 6 Mbps + LTE /B5/Bottom Channel**

**Results: 240 VAC 60 Hz / Neutral / Average**

Frequency (MHz)	Line	Level (dB $\mu$ V)	Limit (dB $\mu$ V)	Margin (dB)	Result
0.34976	Neutral	45.00	49.00	4.00	Complied
4.26187	Neutral	23.10	46.00	22.90	Complied
5.99146	Neutral	25.10	50.00	24.90	Complied
8.99217	Neutral	25.80	50.00	24.20	Complied
9.96864	Neutral	32.20	50.00	17.80	Complied
10.98399	Neutral	30.10	50.00	19.90	Complied

**Result: Pass**

**Plot: 240 VAC 60 Hz / Live and Neutral Line**

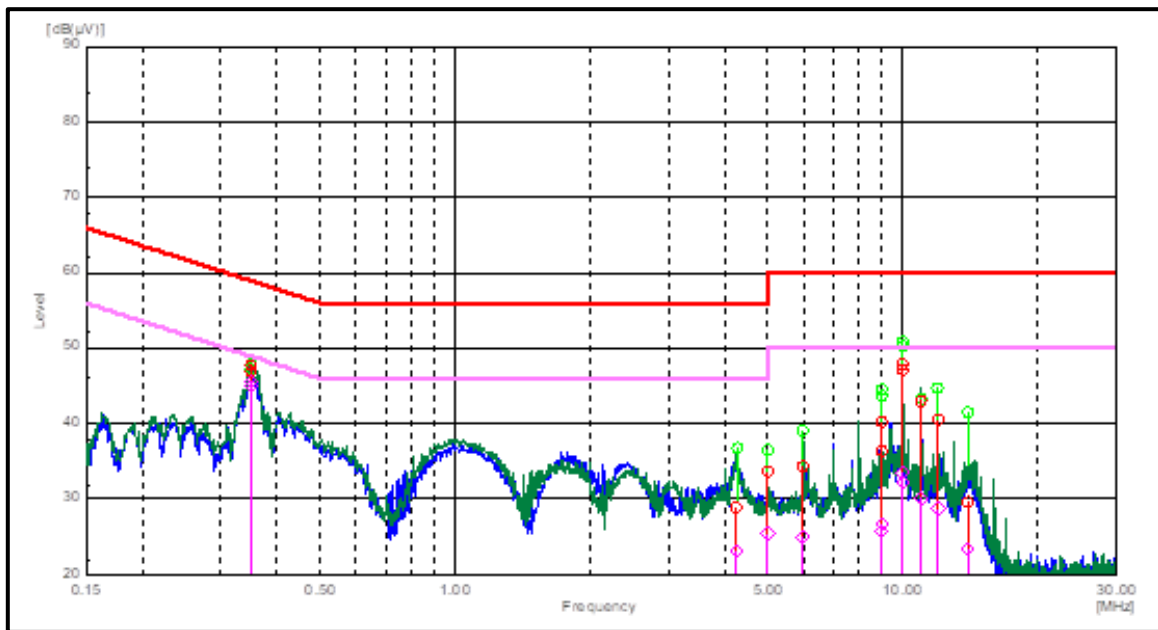

*Note: These plots are pre-scans and for indication purposes only. For final measurements, see accompanying tables.*

**5.2.2. Transmitter Out of Band Radiated Emissions****Test Summary:**

<b>Test Engineer:</b>	Sercan Usta	<b>Test Date:</b>	30 December 2021
<b>Test Sample Serial Number:</b>	100101000221		
<b>Test Site Identification</b>	SR 1/2		

<b>FCC Reference:</b>	Parts 15.407(b)(1),(9) & 15.209(a) & 2.1053 & 22.917(a)
<b>Test Method Used:</b>	FCC KDB 789033 II .G.1, II .G.2, II .G.3 & II .G.4. & ANSI C63.10 Sections 6.3 and 6.4
<b>Frequency Range:</b>	9 kHz to 30 MHz

**Environmental Conditions:**

<b>Temperature (°C):</b>	24.0
<b>Relative Humidity (%):</b>	47.1

**Note(s):**

- In accordance with FCC KDB 414788 D01 Radiated Test Site & ANSI C63.10 clause 5.2 an alternative test site that can demonstrate equivalence to a open area test site may be used. Therefore, the measurement was performed in a Semi Anechoic Chamber. (The OATS / SAC comparison data is available upon request).
- The limits are specified at a test distances of 30 and 300 metres. However, as specified in FCC Section 15.31 (f)(2) & ANSI C63.10 clause 6.4.3, measurements may be performed at a closer distance and the measured level extrapolated to the specified measurement distance using the method described in clauses 6.4.4, specifically sub-clause 6.4.4.1 which specifies that the measured level shall be extrapolated to the specified distance by conservatively presuming that the field strength decays at 40 dB/decade.
- Therefore, the limit values are extrapolated to a measurement distance of 3 m.
  - 9 kHz- 490 kHz: limits extrapolated from 300 m to 3 m by adding 80 dB at 40 dB /decade.
  - 490 kHz-1705 kHz: limits extrapolated from 30 m to 3 m by adding 40 dB at 40 dB /decade
- Pre-scans with the EUT transmitting were measured according to FCC Part 15.407(b)(1) which states for transmitters operating in the band 5.15 to 5.25 GHz: all emissions outside of the band 5.15-5.35 GHz band shall not exceed -27 dBm/MHz. Part(b)(7) states the provisions of 15.205 apply, e.g. restricted bands of operation.
- The preliminary scans showed similar emission levels below 30 MHz, for each channel of operation. Therefore, final radiated emissions measurements were performed with the EUT set to the middle channel only.
- The final measured value, for the given emission in the field strength result tables, incorporates the calibrated antenna factor and cable loss. All other emissions shown on the pre-scan plots were found to be below the measurement system noise floor or ambient, therefore the highest peak noise floor reading of the measuring receiver was recorded in the table below.
- Measurements below 30 MHz were performed in a semi-anechoic chamber SR1/ 2 (Asset Number 1603665) at a distance of 3 m. The EUT was placed at a height of 80 cm above the reference ground plane in the centre of the chamber turntable. The measurement loop antenna height was 80 cm.
- Pre-scans were performed and markers placed on the highest measured levels. The test receiver was set to:
  - Frequency range: 9 kHz-150 kHz: RBW: 1 kHz /VBW: 3 kHz
  - Frequency range: 150 kHz – 30 MHz: RBW: 10 kHz /VBW: 30 kHz
  - Detector: Max-Peak detector

**Transmitter Out of Band Radiated Emissions (continued)**

**Test Setup:**

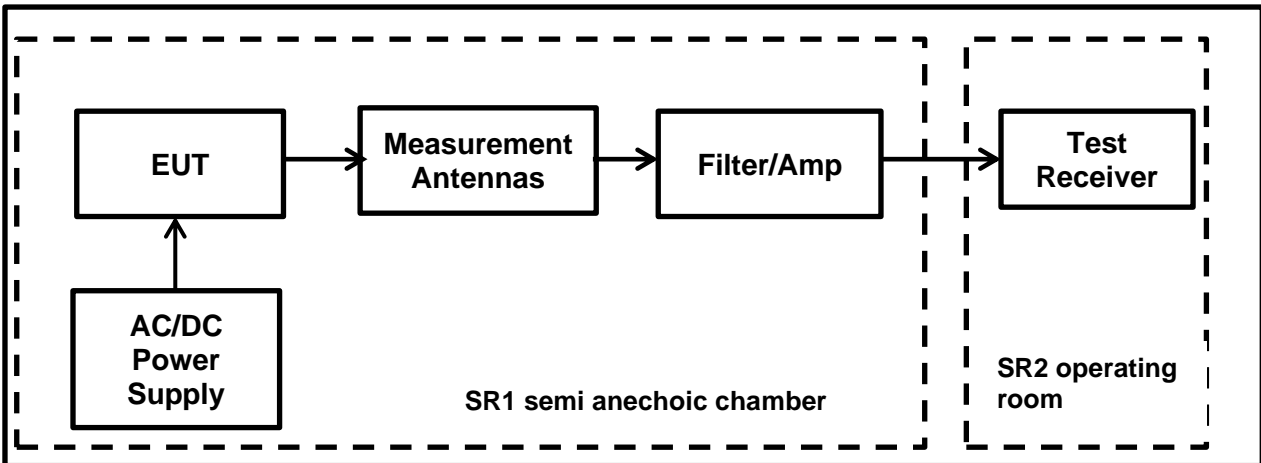

**Transmitter Out of Band Radiated Emissions (continued)**

**Results: WLAN 5 GHz Mode/ UNII-1 / 802.11a / 20 MHz / PWR 12 / Bottom Channel / 6 Mbps + UMTS Band V / Middle Channel**

Frequency (MHz)	Loop Antenna Orientation	MaxPeak Level (dB $\mu$ V/m)	Limit (dB $\mu$ V/m)	Margin (dB)	Result
All emissions were below the level of the measurement system noise floor.					

Plot: 9 kHz – 30 MHz:

**WLAN 5 GHz Mode/ UNII-1 / 802.11a / 20 MHz / PWR 12 / Bottom Channel / 6 Mbps + UMTS Band V / Middle Channel**

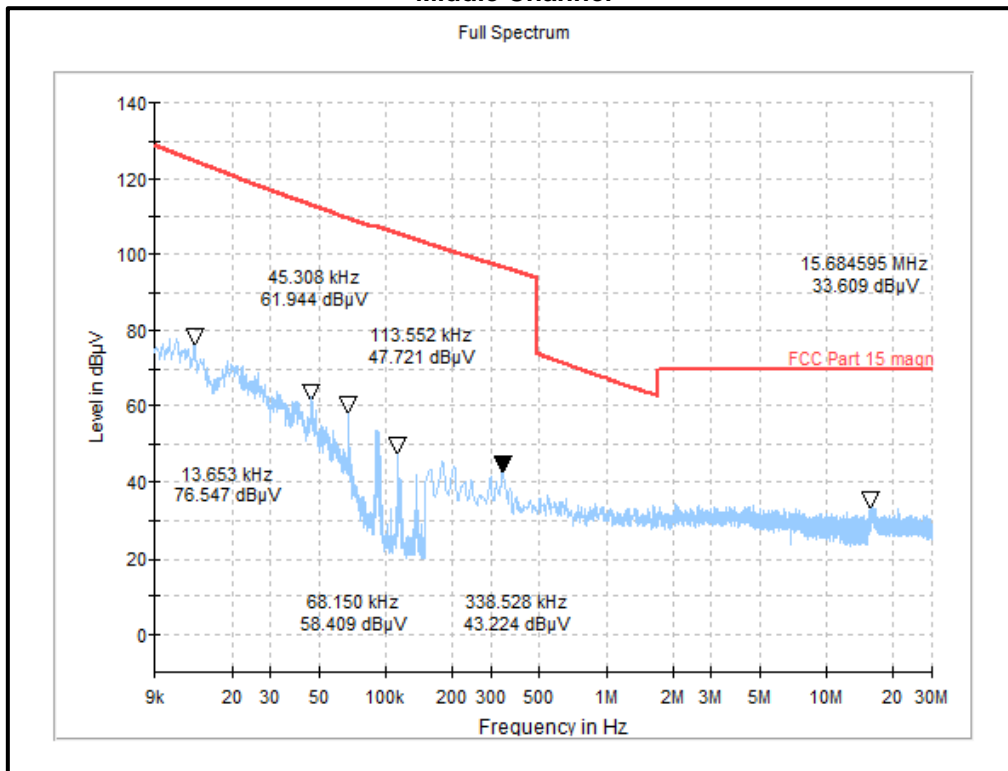

**Result: Pass**

**Transmitter Out of Band Radiated Emissions (continued)**

**Results: WLAN 5 GHz Mode/ UNII-1 / 802.11a / 20 MHz / PWR 12 / Bottom Channel / 6 Mbps + LTE /B5/Bottom Channel**

Frequency (MHz)	Loop Antenna Orientation	MaxPeak Level (dB $\mu$ V/m)	Limit (dB $\mu$ V/m)	Margin (dB)	Result
All emissions were below the level of the measurement system noise floor.					

Plot: 9 kHz – 30 MHz:

WLAN 5 GHz Mode/ UNII-1 / 802.11a / 20 MHz / PWR 12 / Bottom Channel / 6 Mbps + LTE /B5/Bottom Channel

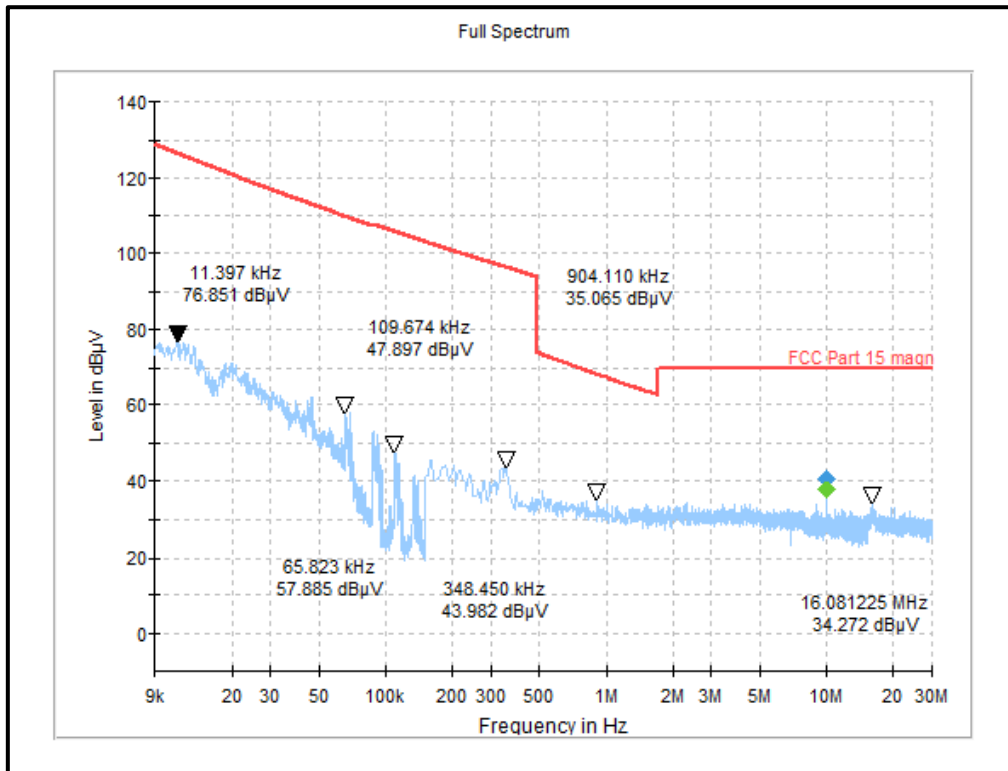

Result: **Pass**

**Transmitter Out of Band Radiated Emissions (continued)****Test Summary:**

<b>Test Engineer:</b>	Sercan Usta	<b>Test Date:</b>	29 December 2021
<b>Test Sample Serial Number:</b>	100101000221 (RF Test Sample with External SMA Connectors)		
<b>Test Site Identification</b>	SR 1/2		

<b>FCC Reference:</b>	Parts 15.407(b)(1),(9) & 15.209(a) & 2.1053 & 22.917(a)
<b>Test Method Used:</b>	FCC KDB 789033 II .G.1, II .G.2, II .G.3 & II .G.4 & ANSI C63.10 Sections 6.3 and 6.5
<b>Frequency Range:</b>	30 MHz to 1000 MHz

**Environmental Conditions:**

<b>Temperature (°C):</b>	24.0
<b>Relative Humidity (%):</b>	47.1

**Note(s):**

- Measurements below 1 GHz were performed in a semi-anechoic chamber SR1/ 2 (Asset Number 1603665) at a distance of 3 m. The EUT was placed at a height of 80 cm above the reference ground plane in the centre of the chamber turntable. Maximum emission levels were determined by height searching the measurement antenna over the range 1 m to 4 m.
- Pre-scans were performed and markers placed on the highest measured levels. The test receiver resolution bandwidth was set to 100 kHz and video bandwidth 300 kHz. A peak detector was used, sweep time was set to auto and trace mode was Max Hold.
- The final measured value, for the given emission, in the table below incorporates the calibrated antenna factor and cable loss.
- All other emissions shown on the pre-scan plots were investigated and found to be below system noise floor.
- The peak in the range of 824 MHz – 894 MHz is the EUT fundamental for the tested channel.
- FCC Part 22.917 Out of band emissions. The power of any emission outside of the authorized operating frequency ranges must be attenuated below the transmitting power (P) by a factor of at least  $43 + 10 \log(P)$  dB, which always comes out to be -13 dBm or 82.2 dB $\mu$ V/m for frequency ranges above 30 MHz
- In accordance with FCC KDB 996369 D04 Section 3.1, The radio spectrum is to be investigated with all the transmitters in the final host product functioning to determine that no emissions exceed the highest limit permitted for any one individual transmitter as required by Section §2.947(f).
- In response to FCC inquiry following limits have been applied  
'When integrating transmitter modules certified under different rule parts into a single host product, the allowable limit for spurious emissions, caused by simultaneous operation, is the highest limit level allowed by any rule part.

**Transmitter Out of Band Radiated Emissions (continued)**

**Test Setup:**

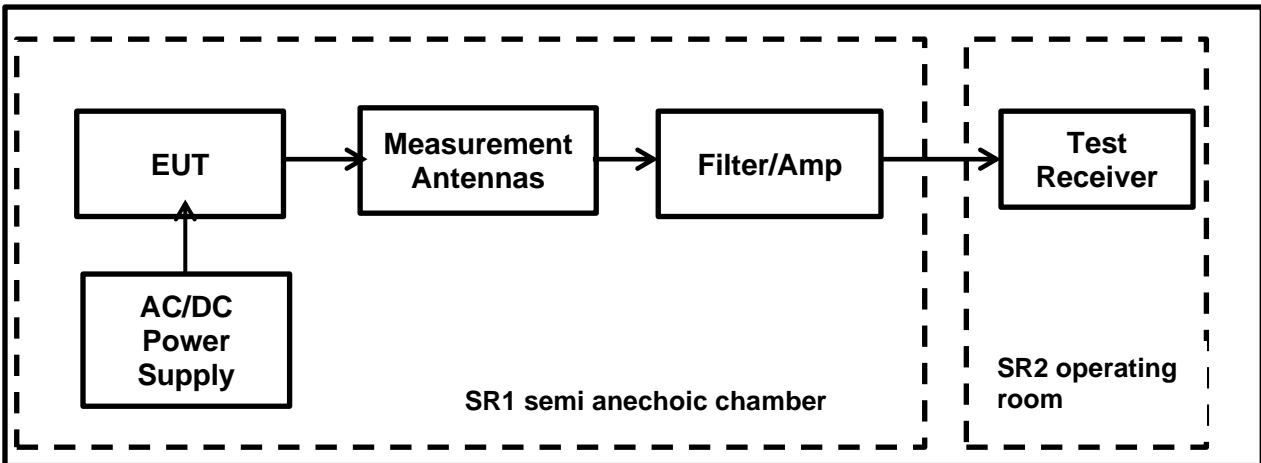



**Transmitter Out of Band Radiated Emissions (continued)**

**Results: WLAN 5 GHz Mode/ UNII-1 / 802.11a / 20 MHz / PWR 12 / Bottom Channel / 6 Mbps + UMTS Band V / Middle Channel**

Frequency (MHz)	Antenna Polarization	MaxPeak Level (dB $\mu$ V/m)	Limit (dB $\mu$ V/m)	Margin (dB)	Result
No critical emissions were found					

Plot: 30 MHz – 1GHz: Plot:

WLAN 5 GHz Mode/ UNII-1 / 802.11a / 20 MHz / PWR 12 / Bottom Channel / 6 Mbps + UMTS Band V / Middle Channel

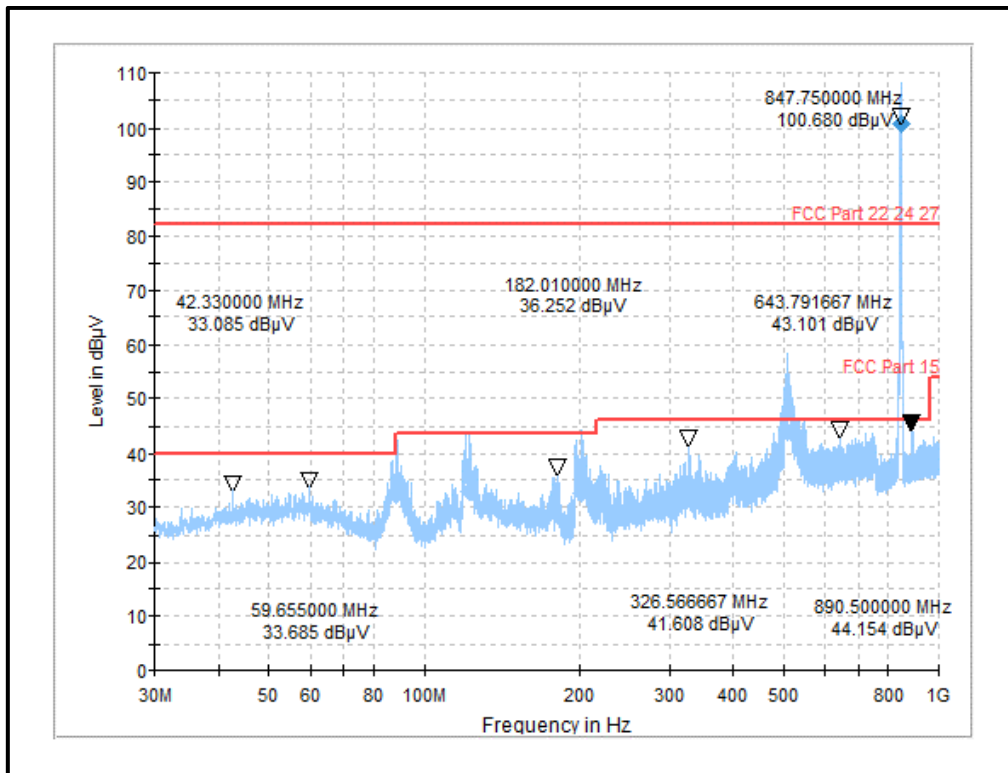

Result: **Pass**

**Transmitter Out of Band Radiated Emissions (continued)**

**Results: WLAN 5 GHz Mode/ UNII-1 / 802.11a / 20 MHz / PWR 12 / Bottom Channel / 6 Mbps + LTE /B5/Bottom Channel**

Frequency (MHz)	Antenna Polarization	MaxPeak Level (dBμV/m)	Limit (dBμV/m)	Margin (dB)	Result
No critical emissions were found					

Plot: 30 MHz – 1GHz:

WLAN 5 GHz Mode/ UNII-1 / 802.11a / 20 MHz / PWR 12 / Bottom Channel / 6 Mbps + LTE /B5/Bottom Channel

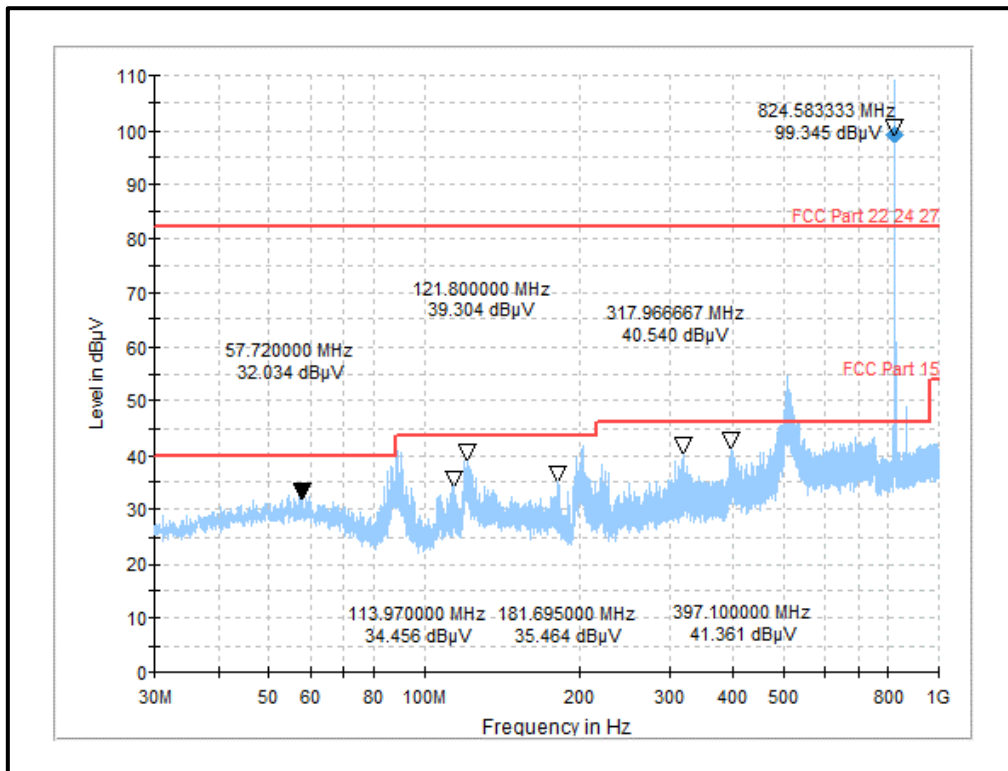

**Result: Pass**

**Transmitter Out of Band Radiated Emissions (continued)****Test Summary:**

<b>Test Engineer:</b>	Sercan Usta	<b>Test Date:</b>	04 January 2022
<b>Test Sample Serial Number:</b>	100101000221 (RF Test Sample with External SMA Connectors)		
<b>Test Site Identification</b>	SR 1/2		

<b>FCC Reference:</b>	Parts 15.407(b)(1),(9) & 15.209(a) & 2.1053 & 22.917(a)
<b>Test Method Used:</b>	FCC KDB 789033 II .G.1, II .G.2, II .G.3, II .G.5 &, II .G.6 ANSI C63.10:2013 Sections 6.3 and 6.6
<b>Frequency Range:</b>	1 GHz to 40 GHz

**Environmental Conditions:**

<b>Temperature (°C):</b>	24.0
<b>Relative Humidity (%):</b>	47.1

**Note(s):**

- The emissions shown at frequencies approximately 5.15-5.25 GHz on the 1 GHz to 18 GHz plots are the EUT fundamental for the tested channel.
- Pre-scans above 1 GHz were performed in a semi-anechoic chamber SR1/ 2 (Asset Number 1603665) with absorber on the floor at a distance of 3 m. The EUT was placed at a height of 1.5 m above the test chamber floor in the centre of the chamber turntable. All measurement antennas were placed at a fixed height of 1.5 m above the test chamber floor, in line with the EUT. Final measurements above 1 GHz were performed in a semi-anechoic chamber SR1/ 2 (Asset Number 1603665) with absorber on the floor at a distance of 3 m. The EUT was placed at a height of 1.5 m above the reference ground plane in the centre of the chamber turntable. Maximum emission levels were determined by height searching the measurement antenna over the range 1 m to 4 m.
- For frequency range between 1 GHz and 18 GHz, the final measured value, for the given emission, in the table below incorporates the calibrated antenna factor and cable loss.
- All other emissions shown on the pre-scan plots were investigated and found to be below system noise floor.
- In accordance with ANSI C63.10-2013 Section 5.3.3 & 6.5.3 measurements above 18 GHz were performed at closer distance (1 m); because at specified measurement distance (3m) for compliance the instrumentation noise floor was typically close to the radiated emission limit.
- For frequency range between 18 GHz and 40 GHz, no critical emissions were found.
- FCC Part 22.917 Out of band emissions. The power of any emission outside of the authorized operating frequency ranges must be attenuated below the transmitting power (P) by a factor of at least  $43 + 10 \log(P)$  dB, which always comes out to be -13 dBm or  $82.2 \text{ dB}\mu\text{V/m}$  for frequency ranges above 30 MHz
- In accordance with FCC KDB 996369 D04 Section 3.1, The radio spectrum is to be investigated with all the transmitters in the final host product functioning to determine that no emissions exceed the highest limit permitted for any one individual transmitter as required by Section §2.947(f).
- In response to FCC inquiry following limits have been applied  
'When integrating transmitter modules certified under different rule parts into a single host product, the allowable limit for spurious emissions, caused by simultaneous operation, is the highest limit level allowed by any rule part.

**Transmitter Out of Band Radiated Emissions Test setup**

**Test Setup:**

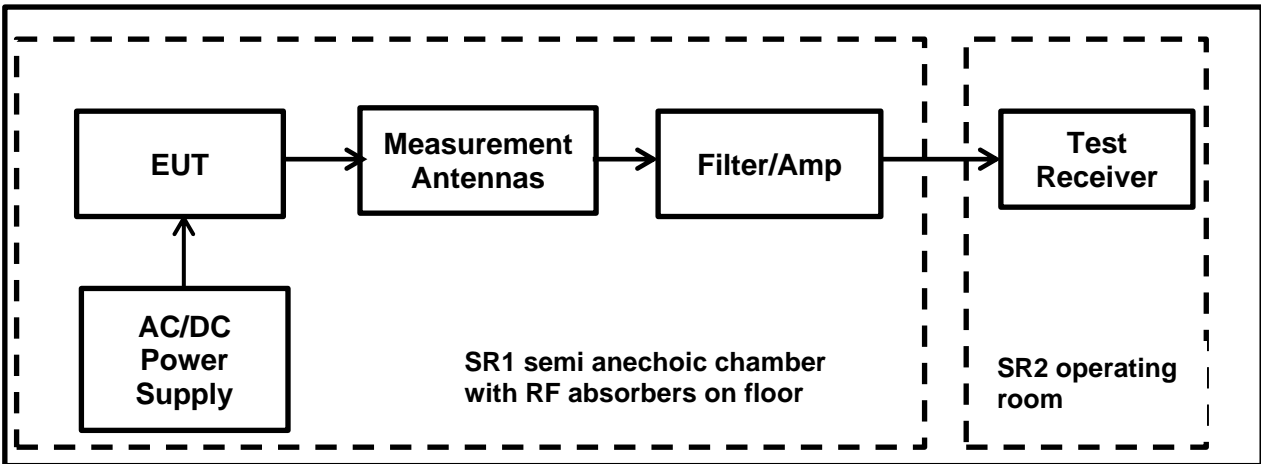

**Transmitter Out of Band Radiated Emissions (continued)**

**Results: WLAN 5 GHz Mode/ UNII-1 / 802.11a / 20 MHz / PWR 12 / Bottom Channel / 6 Mbps + UMTS Band V / Middle Channel**

Frequency (MHz)	Antenna Polarization	Peak Level (dBµV/m)	Limit (dBµV/m)	Margin (dB)	Result
1694.85	Horizontal	40.96	82.20	41.24	Complied
2541.85	Horizontal	46.21	82.20	35.99	Complied

Plot: 1 GHz – 18 GHz:

**WLAN 5 GHz Mode/ UNII-1 / 802.11a / 20 MHz / PWR 12 / Bottom Channel / 6 Mbps + UMTS Band V / Middle Channel**

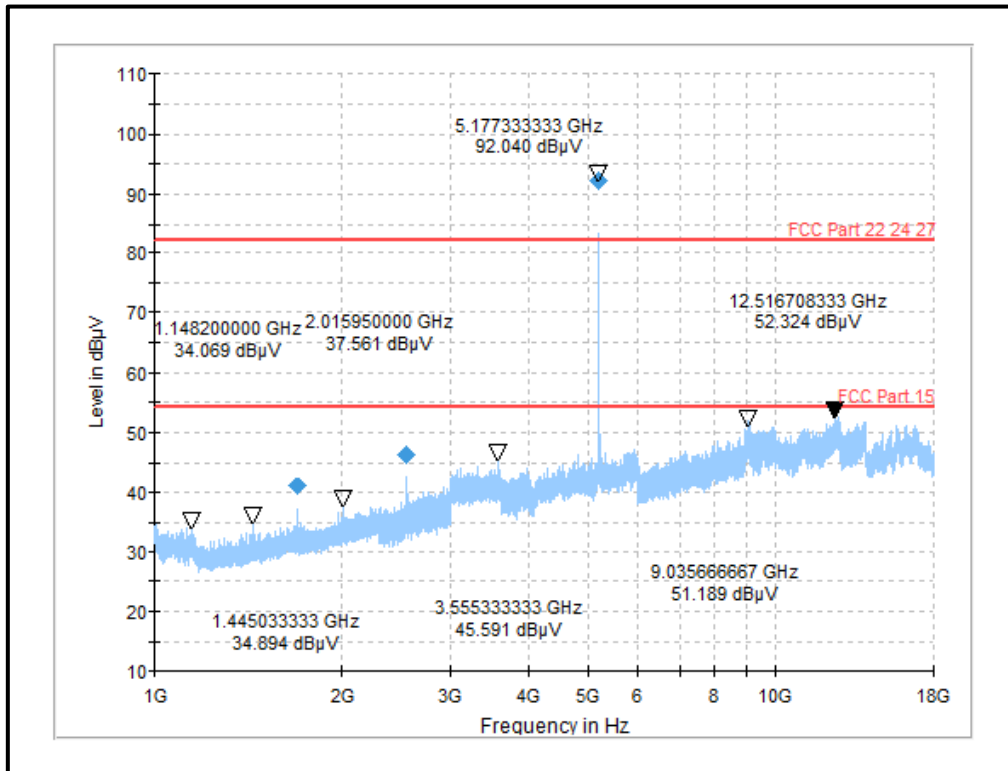

**Result: Pass**

**Transmitter Out of Band Radiated Emissions (continued)**

**Results: WLAN 5 GHz Mode/ UNII-1 / 802.11a / 20 MHz / PWR 12 / Bottom Channel / 6 Mbps + LTE /B5/Bottom Channel**

Frequency (MHz)	Antenna Polarization	Peak Level (dB $\mu$ V/m)	Limit (dB $\mu$ V/m)	Margin (dB)	Result
1648.92	Vertical	72.31	82.20	9.89	Complied
2473.37	Horizontal	73.67	82.20	8.53	Complied
3297.50	Horizontal	71.13	82.20	11.07	Complied
4121.33	Horizontal	66.44	82.20	15.76	Complied
4946.67	Horizontal	70.69	82.20	11.51	Complied

Plot: 1 GHz – 18 GHz:

WLAN 5 GHz Mode/ UNII-1 / 802.11a / 20 MHz / PWR 12 / Bottom Channel / 6 Mbps + LTE /B5/Bottom Channel

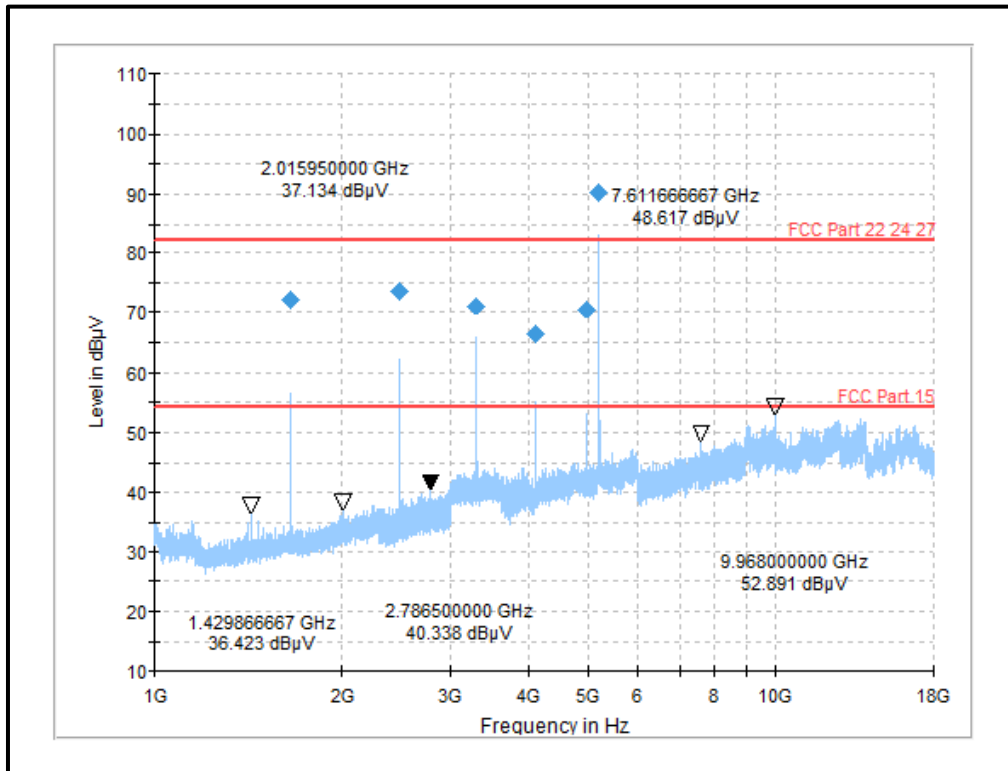

Result: **Pass**

**Transmitter Out of Band Radiated Emissions (continued)**

**Results: WLAN 5 GHz Mode/ UNII-1 / 802.11a / 20 MHz / PWR 12 / Bottom Channel / 6 Mbps + UMTS Band V / Middle Channel**

Frequency (MHz)	Antenna Polarization	Peak Level (dB $\mu$ V/m)	Limit (dB $\mu$ V/m)	Margin (dB)	Result
No critical emissions were found					

Plot: 18 GHz – 40 GHz :

WLAN 5 GHz Mode/ UNII-1 / 802.11a / 20 MHz / PWR 12 / Bottom Channel / 6 Mbps + UMTS Band V / Middle Channel

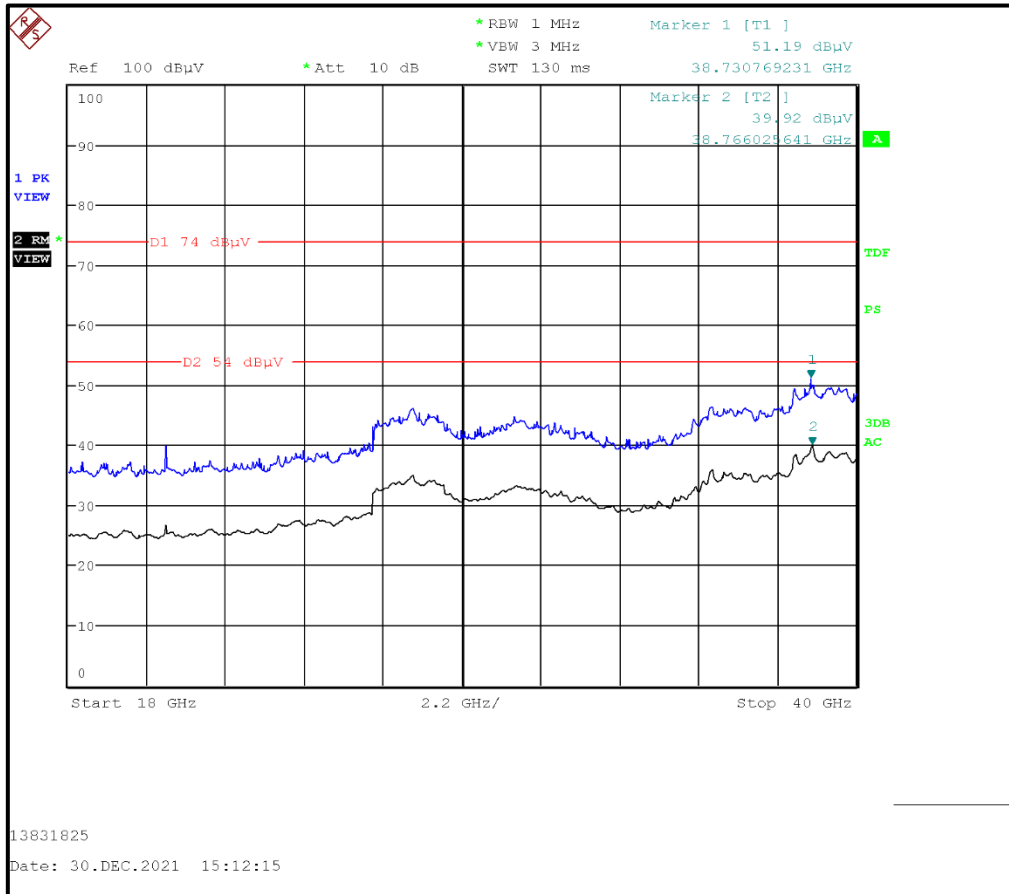

Result: **Pass**

**Transmitter Out of Band Radiated Emissions (continued)**

**Results: WLAN 5 GHz Mode/ UNII-1 / 802.11a / 20 MHz / PWR 12 / Bottom Channel / 6 Mbps + LTE /B5/Bottom Channel**

Frequency (MHz)	Antenna Polarization	Peak Level (dB $\mu$ V/m)	Limit (dB $\mu$ V/m)	Margin (dB)	Result
No critical emissions were found					

Plot: 18 GHz – 40 GHz :

WLAN 5 GHz Mode/ UNII-1 / 802.11a / 20 MHz / PWR 12 / Bottom Channel / 6 Mbps + LTE /B5/Bottom Channel

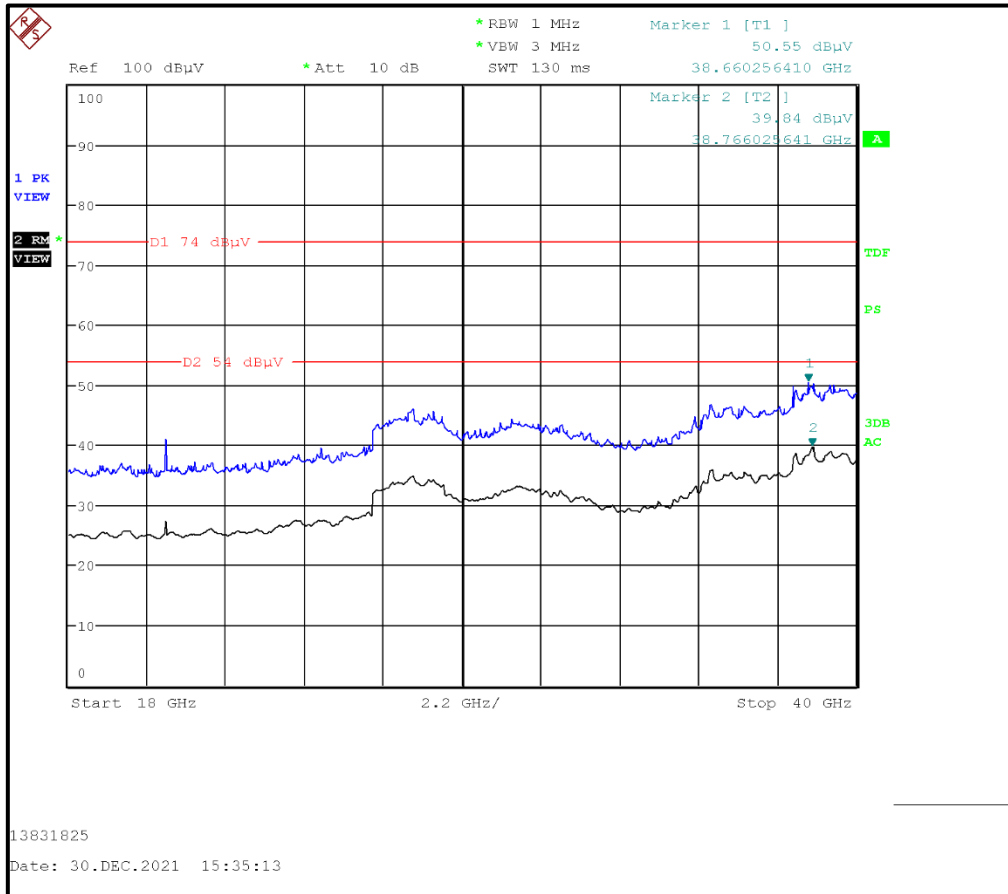

Result: **Pass**



## 6. Measurement Uncertainty

The expression of uncertainty of a measurement result allows realistic comparison of results with reference values and limits given in specifications and standards.

The uncertainty of the result may need to be taken into account when interpreting the measurement results.

The reported expanded uncertainties below are based on a standard uncertainty multiplied by an appropriate coverage factor such that a confidence level of approximately 95% is maintained. For the purposes of this document “approximately” is interpreted as meaning “effectively” or “for most practical purposes”.

Measurement Type	Confidence Level (%)	Calculated Uncertainty
AC Conducted Spurious Emissions	95%	±2.49 dB
Radiated Spurious Emissions	95%	±3.10 dB

The methods used to calculate the above uncertainties are in line with those recommended within the various measurement specifications. Where measurement specifications do not include guidelines for the evaluation of measurement uncertainty the published guidance of the appropriate accreditation body is followed.

## 7. Used equipment

### Test site: SR 1/2

ID	Manufacturer	Type	Model	Serial	Calibration Date	Cal. Cycle (months)
1	Rohde & Schwarz	Antenna, Loop	HFH2-Z2	831247/012	10/07/2020	36
377	BONN Elektronik	Amplifier, Low Noise Pre	BLMA 0118-1A	025294B	16/07/2021	12
423	Bonn Elektronik	Amplifier, Low Noise Pre	BLMA 1840-1A	55929	16/07/2021	12
460	Deisel	Turntable	DT 4250 S	n/a	n/a	n/a
452	Schwarzbeck	Antenna, Trilog Broadband	VULB 9168	9168-240	02/09/2020	24
496	Rohde & Schwarz	Antenna, log. - periodical	HL050	100297	05/08/2020	36
607	Schwarzbeck	Antenna broadband horn antenna	BBHA 9170	9170-561	15/10/2019	36
587	Maturo	antenna mast, tilting	TAM 4.0-E	011/7180311	n/a	n/a
588	Maturo	Controller	NCD	029/7180311	n/a	n/a
591	Rohde & Schwarz	Receiver	ESU 40	100244/040	28/06/2021	12
608	Rohde & Schwarz	Switch Matrix	OSP 120	101227	lab verification	n/a
628	Maturo	Antenna mast	CAM 4.0-P	224/19590716	n/a	n/a
629	Maturo	Kippeinrichtung	KE 2.5-R-M	MAT002	n/a	n/a
-/-	Testo	Thermo-Hygrometer	608-H1	01	lab verification	n/a
1603665	Siemens Matsushita Components	semi-anechoic chamber SR1/2	-/-	B83117-A1421- T161	n/a	n/a

### Test site: SR 7/8

ID	Manufacturer	Type	Model	Serial	Calibration Date	Cal. Cycle (months)
23	Rohde & Schwarz	Artificial Mains Network	ESH3-Z5	831767/013	14/07/2021	12
349	Rohde & Schwarz	Receiver, EMI Test	ESIB7	836697/009	13/07/2021	12
-/-	Testo	Thermo-Hygrometer	608-H1	08	lab verification	n/a
327	SPS	AC/DC power distribution system	PAS 5000	A2464 00/1 0200	lab verification	n/a

### 8. Report Revision History

Version Number	Revision Details		
	Page No(s)	Clause	Details
1.0	36	-	Initial Version
<p><b>Test Report Version 1.1 supersede Version 1.0 with immediate effect</b>                      Test Report No. UL-RPT-RP-13831825-716-3-FCC Version 1.1, Issue Date 08 APRIL 2022 replaces                      Test Report No. UL-RPT-RP-13831825-716-3-FCC Version 1.0, Issue Date 31 MARCH 2022, which is no longer valid.</p>			
1.1	as below	as below	Current Version
	1	-	"Infarm Gateway WiFi" replaced with "Infarm Gateway"
	1	-	"Contains FCC ID : 2APW6-FIN0110-CM2 (Bluetooth Low Energy / WiFi 2.4GHz / WiFi 5 GHz) & Contains FCC ID: QIPPLS62-W (Cellular)" replaced with ""Contains 2A2CI-INF001-WF" and "Contains 2A2CI-INF001-CL"
	6	2.2	Note 1 updated with FCC ID references
	6	2.3	ANSI C63.26 details added
	7	3.1	"Infarm Gateway WiFi" replaced with "Infarm Gateway" "Contains FCC ID : 2APW6-FIN0110-CM2 (Bluetooth Low Energy / WiFi 2.4GHz / WiFi 5 GHz) & Contains FCC ID: QIPPLS62-W (Cellular)" replaced with ""Contains 2A2CI-INF001-WF" and "Contains 2A2CI-INF001-CL"
	7	3.2	References to GSM 850 & 1900 removed
	8	3.4	Updated FCC ID references Max power detail deleted
	10	4.1	Updated FCC ID references

--END of Test Report--