

SPECIFICATIONS

Customer	
Product Name	Chip Antenna
Shannon Part Number	SNCA-2480-S2TF
Customer Part Number	

New Released, Revised]

SPEC No.: PH018-12

【This SPEC is total 9 pages including specifications and appendix.】

【ROHS Compliant Parts】

Approved By	Checked By	Issued By

Shenzhen Shannon Semiconductor Co., Ltd.

【For Customer approval Only】

Date: _____

Qualification Status: Full Restricted Rejected

Approved By	Verified By	Re-checked By	Checked By

Comments:

【Version change history】

Rev.	Effective Date	Changed Contents	Change reasons	Approved By
01	8.15,2018	New Release	/	Qiang Zhang

1. Scope

This specification applies to SNCA-2480-S2TF of Multi-layer Chip Antenna.

2. Product Description and Identification (Part Number)

- 1) Description :Multi-layer Chip Antenna
- 2) Product Identification (Part Number)

SNCA 2480 S2 T F
 ① ② ③ ④ ⑤

① Type		② Center Frequency		③ Series Code	
SNCA	Shannon Semi	2480M	2480.0MHz	S2	
④ Packing		⑤ Hazardous Substance Free Products			
T	Tape Carrier Package	F			

3. Electrical Characteristics

Part Number	Band Width	Peak Gain	Average Gain	VSWR	Impedance	Power Capacity
	MHz	2.5 dBi	0.5 dBi	In BW	Ω	W
SNCA-2480-S2TF	≥100	@(XZ-total)	@(XZ-total)	< 2	50	2 W max

- 1) Operating and storage temperature range (individual chip without packing): -40°C ~ +85°C.
- 2) Storage temperature range (packaging conditions): -10°C ~ +40°C and RH 70% (Max.).
- 3) Test equipment: Network Analyzer: E5071B.
- 4) Measuring diagram.

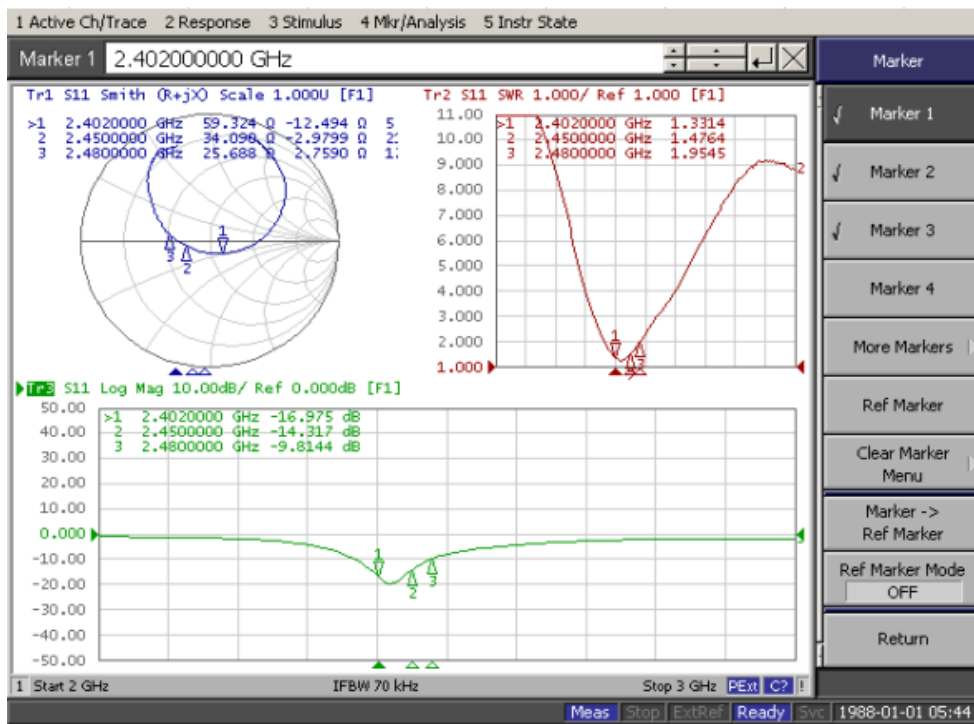

4. Shape and Dimensions

Dimensions and recommended PCB pattern for reflow soldering:

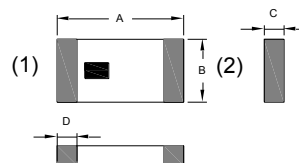
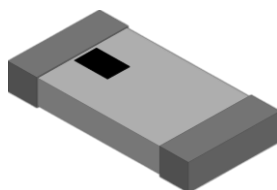

Item	A	B	C	D
SNCA-2480-S2TF	3.2±0.2	1.6±0.2	0.5±0.1	0.5±0.2

Unit: mm

Demo-board:

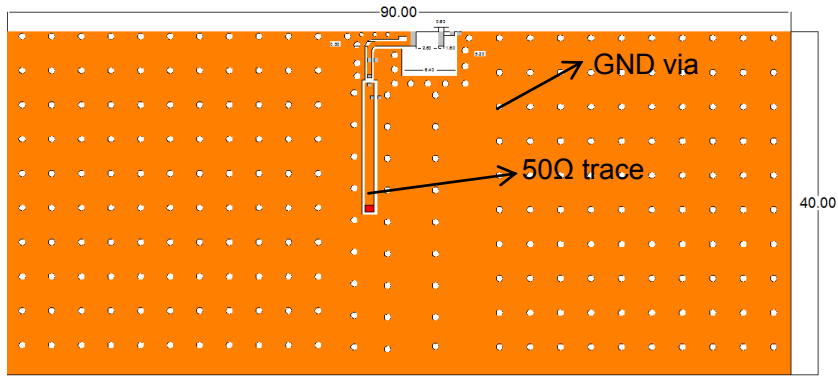

Top view

Unit: mm

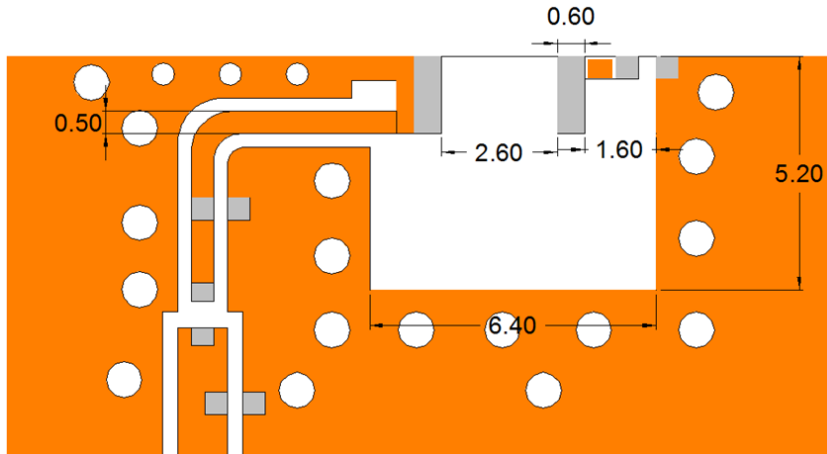

Detail view

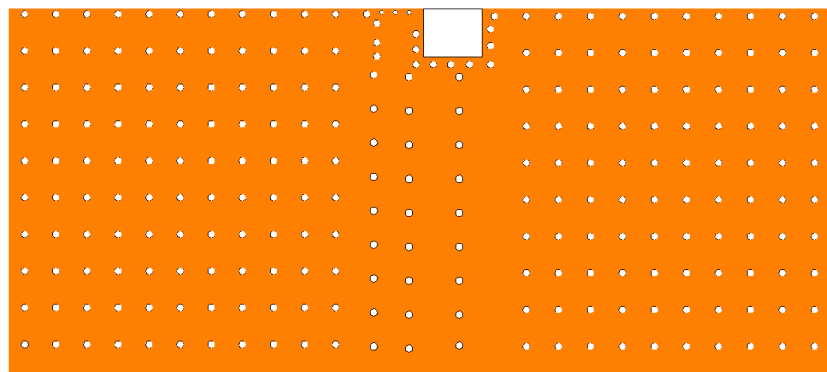

Bottom view

1) Terminal Configuration:

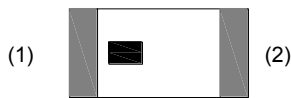

No.	Terminal Name	No.	Terminal Name
(1)	Feeding Point	(2)	Soldering terminal

5. Test and Measurement Procedures

5.1 Test Conditions

Unless otherwise specified, the standard atmospheric conditions for measurement/test as:

- a. Ambient Temperature: 20±15°C
- b. Relative Humidity: 65±20%
- c. Air Pressure: 86 Pa to 106KPa

If any doubt on the results, measurements/tests should be made within the following limits:

- a. Ambient Temperature: 20±2°C
- b. Relative Humidity: 65±5%
- c. Air Pressure: 86KPa to 106KPa

5.2 Visual Examination

- a. Inspection Equipment: 20 X magnifier

5.3 Reliability Test

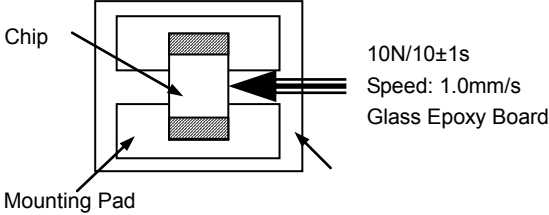
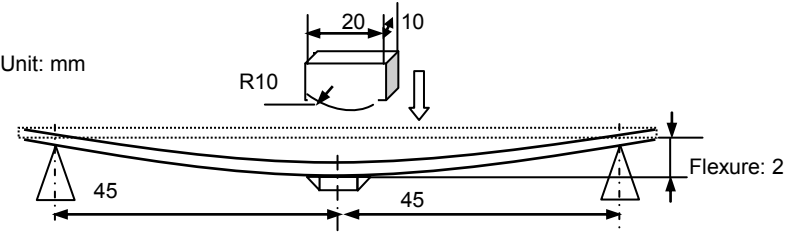
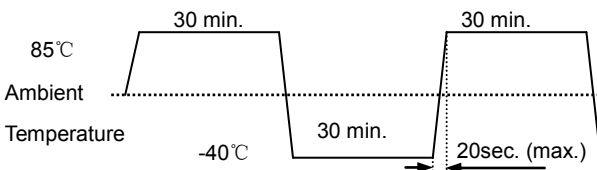
Items	Requirements	Test Methods and Remarks
5.3.1 Terminal Strength	No visible mechanical damage.	① Solder the Antenna to the testing jig (glass epoxy board shown as the following figure) using leadfree solder. Then apply a force in the direction of the arrow. ② 10N force for 3216 series. ③ Keep time: 10±1sec. 
5.3.2 Resistance to Flexure	No visible mechanical damage.	① Solder the chip to the test jig (glass epoxy board) using a leadfree solder. Then apply a force in the direction shown as the following figure. Solder the chip to the test jig (glass epoxy board) using leadfree solder. Then apply a force in the direction. ② Flexure: 2mm ③ Pressurizing Speed: 0.5mm/sec ④ Keep time: ≥30 sec 
5.3.3 Dropping	No visible mechanical damage.	SNCA series: Drop the chip 5 times on a wood floor from a height of 50 cm.
5.3.4 Solderability	① No visible mechanical damage. ② Wetting shall be exceeded 75% coverage.	① Solder temperature: 240±2℃ ② Duration: 3sec ③ Solder: Sn/3.0Ag/0.5Cu ④ Flux: 25% Resin and 75% ethanol in weight
5.3.5 Resistance to Soldering Heat	No visible mechanical damage.	① Solder temperature: 260±5℃ ② Duration: 5 sec ③ Solder: Sn/3.0Ag/0.5Cu ④ Flux: 25% Resin and 75% ethanol in weight ⑤ The chip shall be stabilized at normal condition for 1~2 hours before measuring.
5.3.6 Thermal Shock	① No visible mechanical damage. ② Satisfy electrical Characteristic.	① Temperature and time: -40℃ for 30±3 min→85℃ for 30±3min ② Transforming interval: Max. 20 sec. ③ Tested cycle: 10 cycles ④ The chip shall be stabilized at normal condition for 1~2 hours before measuring. 

<p>5.3.7 Damp Heat (Steady States)</p>	<p>① No visible mechanical damage. ② Satisfy electrical Characteristic.</p>	<p>① Temperature: 60±2℃ ② Humidity: 90% to 95% RH ③ Duration: 96⁺²⁴ hours ④ The chip shall be stabilized at normal condition for 1~2 hours before measuring.</p>
<p>5.3.8 Resistance to High temperature</p>	<p>① No visible mechanical damage. ② Satisfy electrical Characteristic.</p>	<p>① Temperature: 85±2℃ ② Duration: 96⁺²⁴ hours ③ The chip shall be stabilized at normal condition for 1~2 hours before measuring.</p>

6. Packaging and Storage

6.1 Packaging

There is one type of packaging for the Multi-layer Chip Antennas. Please specify the packing code when ordering.

6.1.1 Tape Carrier Packaging:

Packaging code: T

- a. Tape carrier packaging are specified in attached figure Fig. 6.1-1~3
- b. Tape carrier packaging quantity please see the following table:

Type	3216[1206]
Tape	Paper Tape
Quantity	3K

(1) Taping Drawings (Unit: mm)

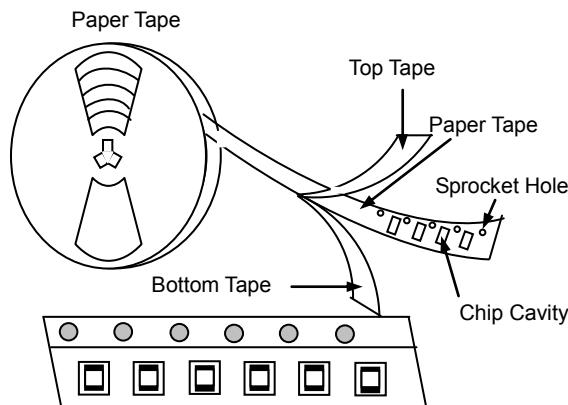
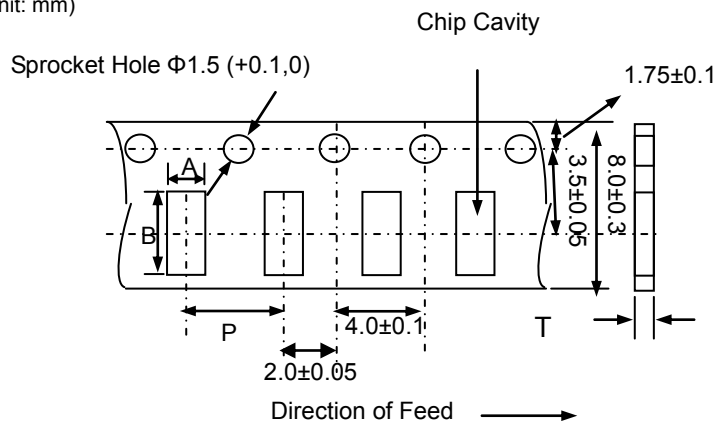

Fig. 6.1-1

Remark: The sprocket holes are to the right as the tape is pulled toward the user.

(2) Taping Dimensions (Unit: mm)



Type	Chip Thickness	A	B	P	T max
SNCA-2480-S2TF	0.5±0.1	1.8±0.1	3.5±0.1	4.0±0.10	0.75

(3)Reel Dimensions (Unit: mm)

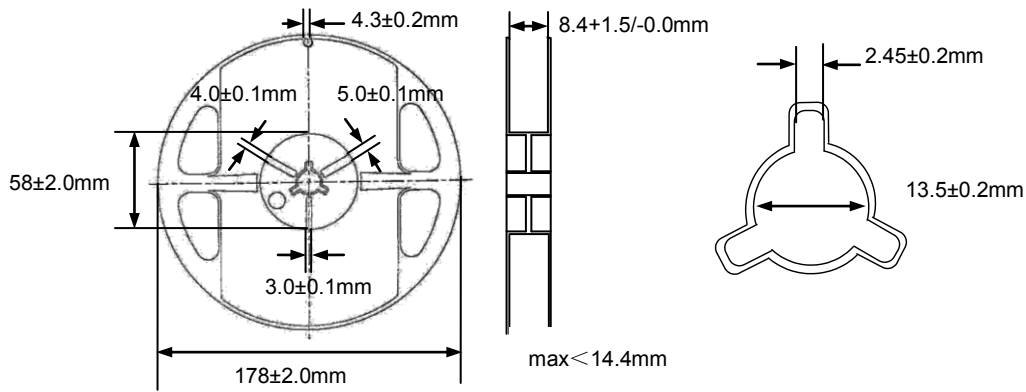

Fig. 6.1-3

6.2 Storage

- a. The solderability of the external electrode may be deteriorated if packages are stored where they are exposed to high humidity. Package must be stored at 40°C or less and 70% RH or less.
- b. The solderability of the external electrode may be deteriorated if packages are stored where they are exposed to dust of harmful gas (e.g. HCl, sulfurous gas of H₂S).
- c. Packaging material may be deformed if package are stored where they are exposed to heat of direct sunlight.
- d. Solderability specified in **Clause 5.3.5** shall be guaranteed for 12 months from the date of delivery on condition that they are stored at the environment specified in **Clause 3**. For those parts, which passed more than 12 months shall be checked solder-ability before use.

7. Recommended Soldering Technologies

7.1 Reflow Profile

- △ Preheat condition: 150 ~200°C/60~120sec.
- △ Allowed time above 217°C: 60~90sec.
- △ Max temp: 260°C
- △ Max time at max temp: 10sec.
- △ Solder paste: Sn/3.0Ag/0.5Cu
- △ Allowed Reflow time: 2x max

[Note: The reflow profile in the above table is only for qualification and is not meant to specify board assembly profiles. Actual board assembly profiles must be based on the customer's specific board design, solder paste and process, and should not exceed the parameters as the Reflow profile shows.]

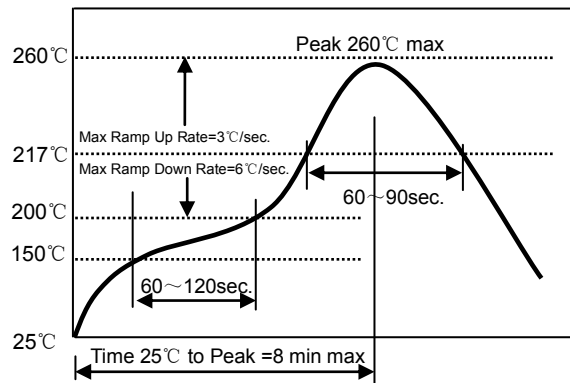

7.2 Iron Soldering Profile

- △ Iron soldering power: Max.30W
- △ Pre-heating: 150 °C / 60 sec.
- △ Soldering tip temperature: 350°C Max.
- △ Soldering time: 3 sec Max.
- △ Solder paste: Sn/3.0Ag/0.5Cu
- △ Max.1 times for iron soldering

[Note: Take care not to apply the tip of the soldering iron to the terminal electrodes.]

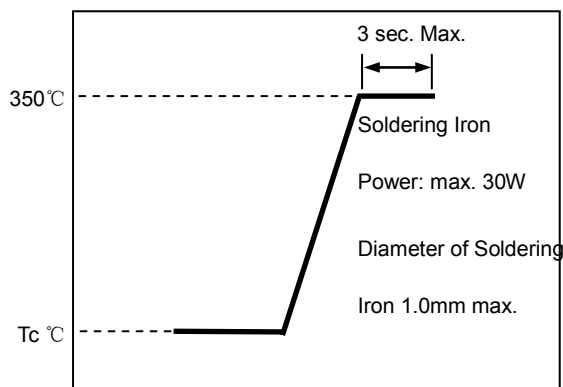

8. Supplier Information

- a) Supplier:
Shenzhen Shannon Semiconductor Co., Ltd.
- b) Manufacturer:
Shenzhen Shannon Semiconductor Co., Ltd.
- c) Manufacturing Address:
Shenzhen nanshan district and high - tech zone Gao Xinnan four W2 - 502 A
Zip: 518000

Appendix 1

Efficiency table:

Frequency	Efficiency (%)	Efficiency . dB
2400	70.42	-1.52
2410	76.51	-1.16
2420	76.45	-1.17
2430	77.51	-1.10
2440	77.58	-1.10
2450	79.09	-1.01
2460	79.88	-0.92
2470	79.45	-1.00
2480	78.79	-1.04
2490	77.39	-1.16
2500	75.33	-1.26

Radiation pattern:

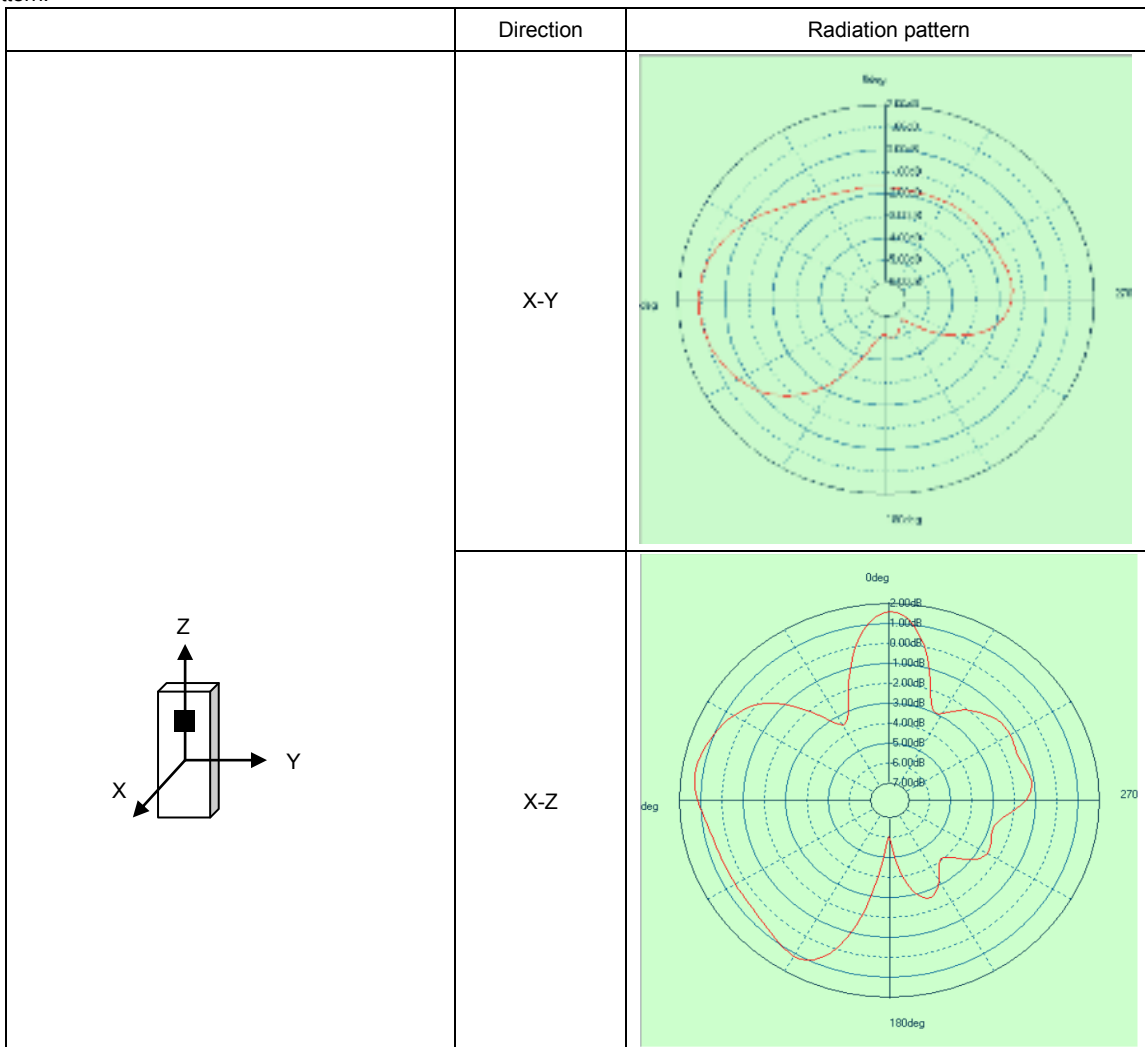

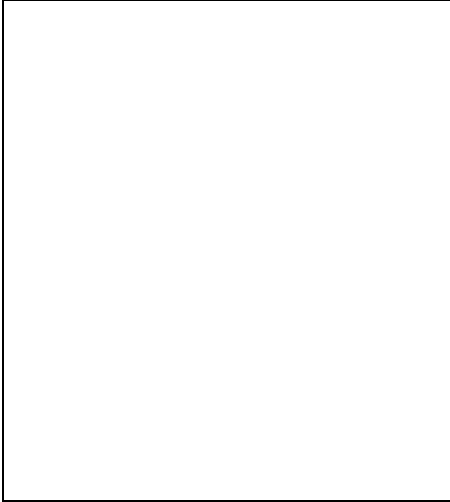

Y-Z

