

Copyright

Edition: B00

Date: 2021/03

Part No: 046-001230-07

Product Name: Vital Signs Monitor

Product Model: NC3/NC3A/NC3B

Statement

Shenzhen Comen Medical Instruments Co., LTD. (“Comen” or “Comen Company”) possesses the copyright of the non-published Instruction Manual, and has the right to handle it as confidential data. This Instruction Manual is only used as the reference data for the operation, maintenance and servicing of Comen products.

The others have no right to disclose the content of this Instruction Manual to any third person.

This manual contains the proprietary information which is protected by copyright law. With copyright reserved, any person shall not photocopy or duplicate any part of this manual or translate it into any other language without the prior written permission of Comen Company.

Comen Company shall not assume responsibility for the incidental or consequential damages resulting from any errors in this manual or from the provision, actual performance and use of this manual. Comen Company shall not provide the proprietary right vested by patent law to any third party. Comen Company shall not assume legal responsibility for the legal consequences resulting from violating the patent law and the rights of any third party.

Contents in this manual are subject to change without prior notice.

Guarantee

Under the following conditions, Comen Company shall be responsible for the safety, reliability and performance of the product:

- The product shall be used according to the Instruction Manual.
- The installation, maintenance and upgrading of the product shall be conducted by personnel recognized or authorized by Comen Company.
- The storage environment, working environment and electrical environment of the product comply with the product specifications.
- The serial number tag or manufacturing mark of the product shall be clear and

identifiable. It is verified through the appraisal of Comen Company that this product is manufactured by Comen Company.

- Any damage to the monitor will be as the result of unforeseen circumstances (such as accidental dropping or deliberate damage).

The products that are under the warranty service regulations of Comen Company shall enjoy free service. As for the products that are beyond the warranty service regulations, Comen Company shall charge for the service. If the products are transported to Comen Company for maintenance, the user shall bear the freight (including the customs expenses).

Return of Products

If the products need to be returned to Comen Company, please follow the following steps:

Acquisition of the right to return the goods: Contact the after-sales department of Comen Company, tell it the number of the instrument made by Comen; this number was printed on the equipment nameplate; if this instrument number is not legible, the goods returned shall not be accepted. Please specify the instrument number and production date, and briefly describe the reason for returning the goods.

After-sales Service Unit

Name: After-sales Service Department of Shenzhen Comen Medical Instruments Co., LTD.

Address: Floor 10 of Building 1A, FIYTA Timepiece Building, Nanhuan Avenue, Matian Sub-district, Guangming District, Shenzhen, Guangdong, 518106, P.R. China

Tel.: +86-755-26431236, +86-755-86545386, +86-755-26074134

Fax: +86-755-26431232

Customer Service Hotline: +86-755-4007-009-488

Preface

In this Instruction Manual, the performance, operation method and other safety information of the NC3/NC3A/NC3B Vital Signs Monitor (hereinafter referred to as Vital Signs Monitor or Monitor) are described in detail.

Intended users of this manual

This instruction manual is intended to be read by professional clinical medical staff or persons who are experienced in using monitoring equipment. The readers shall have knowledge and working experience in medical procedure, practice and terms necessary for monitoring the patients.

Figures

All the figures provided in this Instruction Manual are for your reference only. The menus, options, values and functions in the figures may be not entirely consistent with what is shown on the monitor.

Conventions

- —>: This symbol is used to indicate an operating step.
- [Character] is used to indicate a character string in the software.

Blank page

Content

Chapter 1 Safety	1-1
1.1 Safety Information.....	1-1
1.2 Contraindications.....	1-5
1.3 Equipment Symbols.....	1-5
Chapter 2 General.....	2-1
2.1 Product Introduction.....	2-1
2.1.1 Composition	2-1
2.1.2 Intended Application	2-1
2.2 Overview of the Monitor	2-1
2.2.1 Key Functions.....	2-3
2.3 External Interface of the Monitor	2-4
2.3.1 Left Panel	2-4
2.3.2 Right Panel	2-5
2.3.3 Rear Panel.....	2-6
2.3.4 Base Cover	2-7
2.4 Screen Display.....	2-7
Chapter 3 Installation of the Monitor.....	3-1
3.1 Unpacking and Examination	3-2
3.2 Environmental Requirements	3-2
3.3 Connect the AC Power Cord	3-3
3.4 Battery	3-4
3.5 Connecting Accessories.....	3-5
3.6 Power On/Off	3-5
3.6.1 Check before Power on	3-5
3.6.2 Power on.....	3-6
3.6.3 Power off.....	3-6
Chapter 4 Patient Safety	4-1
4.1 Safety Instruction	4-1
4.2 Environment	4-1
4.3 Grounding Protection	4-1
4.4 Equipotential Grounding	4-2
4.5 Condensation.....	4-3
Chapter 5 System Settings	5-1
5.1 Measuring Mode.....	5-1

5.2 Parameter Setting Mode	5-2
5.3 Review Mode	5-2
5.4 Standby Mode.....	5-3
5.4.1 Enter the Standby Mode	5-3
5.4.2 Out of the Standby Mode	5-3
5.5 Maintenance Mode	5-3
5.5.1 NIBP Unit Setting.....	5-4
5.5.2 Temp Unit Setting.....	5-5
5.5.3 System Time Setting.....	5-5
5.5.4 NIBP Module Testing.....	5-6
5.5.5 Brightness Adjust.....	5-6
5.5.6 the Factory Default Configuration Restoring	5-7
5.5.7 Demo mode	5-7
5.5.8 Deleting record	5-8
Chapter 6 Battery	6-1
6.1 General	6-1
6.2 Battery Charging	6-2
6.3 Installing Battery	6-3
6.4 Battery Using Guidance	6-3
6.5 Optimization and Check of Battery Performance.....	6-4
6.6 Battery Recovery	6-6
Chapter 7 Cleaning and Disinfection.....	7-1
7.1 Overview	7-1
7.2 Cleaning and Disinfection of Monitor.....	7-2
7.3 Cleaning and disinfection of accessories.....	7-3
7.3.1 Cuff Cleaning and Disinfection.....	7-3
7.3.2 Cleaning and disinfection of other accessories.....	7-4
Chapter 8 Maintenance.....	8-1
8.1 Maintenance and Check	8-1
8.2 Maintenance Schedule.....	8-2
8.3 NIBP Air Leakage Check	8-3
8.4 NIBP Pressure Calibration.....	8-4
8.5 Calibrating NIBP	8-6
Chapter 9 SpO₂ Monitoring	9-1
9.1 General	9-1

9.2 SpO ₂ Contraindications	9-2
9.3 Identifying SpO ₂ Sensor	9-2
9.4 Safety Information.....	9-2
9.5 SpO ₂ Accuracy Test.....	9-4
9.6 PR Accuracy Determination	9-4
9.7 SpO ₂ Verify.....	Error! Bookmark not defined.
9.8 Measuring SpO ₂	9-4
9.9 Limits in Measurement.....	9-7
9.10 Setting Pulse Sound.....	9-8
9.11 Display.....	9-8
9.12 Masimo Information.....	9-9
Chapter 10 NIBP Monitoring	10-1
10.1 General	10-1
10.2 NIBP Contraindications.....	10-1
10.3 Safety Information.....	10-1
10.4 NIBP Measurement	10-3
10.4.1 Preparation for Measuring.....	10-3
10.4.2 Applying Cuff.....	10-4
10.4.3 Measurement Limitations	10-5
10.4.4 Starting Automatic Measurements.....	10-7
10.4.5 Starting /Stopping Manual Measurements.....	10-7
10.5 NIBP Display.....	10-8
Chapter 11 TEMP Monitoring	11-1
11.1 Temperature Monitoring.....	11-1
11.2 Infrared Ear Thermometer	11-1
11.2.1 Front View	11-1
11.2.2 Side View.....	11-2
11.2.3 Temp Measurement	11-2
11.2.4 Wireless Transmission Function.....	11-3
11.3 TEMP Display	11-5
Appendix I Accessories	I-1
Appendix II Reusable Accessory Service Life	II-1
Appendix III Product Specification	III-1
Appendix IV Fault Code Information	IV-1
Appendix V EMC.....	V-1

Chapter 1 Safety

1.1 Safety Information

Warning

- To warn you of the conditions where serious consequence, disadvantageous matters or danger may occur. Failure to comply with the warning will result in severe personal injury or death of the user or the patient.

Caution

- To indicate potential danger or unsafe operation. If not avoided, it may lead to mild personal injury, product malfunction, damages or property loss. It may also give rise to more severe harm.

Attention

- It emphasizes primary warnings or provides descriptions or explanations so that this product can be used in a better way.

Warning

- This monitor is used for monitoring clinical patients, so only doctors and nurses who are qualified through training can use this monitor.
- Do not position the equipment to make it difficult to operate the power plug which is used to isolate the equipment circuits electrically from the mains supply.
- There is no alarm system for the monitor, it only provides fault codes for

Safety

reference. And also it is not suitable for continuous monitoring, please pay close attention to the patient's condition to avoid any delay of the diagnosis.

- Before use, the user shall check whether this instrument and its accessories can work normally and safely.
- Please assure a continuous power supply when monitoring patient, data will be lost if unexpectedly powered down.
- This instrument can only be connected to a power socket with protective grounding or rechargeable batteries for power supply.
- Do not open the shell of this instrument to avoid possible electric shock hazard. The maintenance and upgrading of this monitor must be conducted by service personnel trained and authorized by Comen Company.
- The disposal of packaging materials shall comply with the local laws and regulations or the waste disposal rules and regulations of the hospital. The packaging materials must be placed away from children.
- Do not use this instrument at the place where there are flammable articles such as flammable anesthetic to prevent explosion or fire from happening.
- Please carefully install the power lines and the cables for various accessories to avoid the patient from being constricted or suffocated or avoid the cables from getting entangled and keep the patient free from electrical interference.
- Do not use mobile phones near the monitor, because mobile phones will generate a very strong radiation field and disturb the functions of the monitor.
- When the monitor is used with HF surgical equipment, the transducer and the cables must avoid conductive connection to the HF equipment to protect against burns to the patient.
- Before reusing these cables, check whether they are functioning normally.
- The equipment connected with the monitor shall form an equipotential body (the protective grounding wire is effectively connected).
- When the monitor is shared with an electrosurgery unit, the user (doctor or nurse) shall ensure the patients safety.
- An electromagnetic field will affect the performance of this instrument,

so the use of the other equipment near this instrument must meet corresponding EMC requirements. For example: Mobile phone, X-ray or MRI equipment may be an interference source, because they will transmit high-strength electromagnetic radiation.

- This is not a treatment device.
- The duration of temperature monitoring should be less than 5 minutes.
- Continuous and prolonged period of NIBP monitoring may increase the risk of undesirable changes in the skin characteristics, such as extreme sensitivity, reddening, blistering, or even pressure necrosis etc.
- This device complies with Part 15 of the FCC Rules. Operation is subject to the following two conditions: (1) this device may not cause harmful interference, and (2) this device must accept any interference received, including interference that may cause undesired operation.
- Changes or modifications not expressly approved by the party responsible for compliance could void the user's authority to operate the equipment.
- This equipment has been tested and found to comply with the limits for a Class B digital device, pursuant to Part 15 of the FCC Rules. These limits are designed to provide reasonable protection against harmful interference in a residential installation. This equipment generates uses and can radiate radio frequency energy and, if not installed and used in accordance with the instructions, may cause harmful interference to radio communications. However, there is no guarantee that interference will not occur in a particular installation.
- If this equipment does cause harmful interference to radio or television reception, which can be determined by turning the equipment off and on, the user is encouraged to try to correct the interference by one or more of the following measures:
 - Reorient or relocate the receiving antenna.
 - Increase the separation between the equipment and receiver.
 - Connect the equipment into an outlet on a circuit different from that to which the receiver is connected.
 - Consult the dealer or an experienced radio/TV technician for help.



Caution

Safety

- **To avoid damage to this instrument and guarantee patient safety, please use the accessories designated in this instruction manual.**
- **Please properly install or move this instrument and prevent the instrument from being damaged due to fall, collision, strong vibration or other external mechanical forces.**
- **Before the instrument is switched on, please confirm whether the power supply used meets the requirements for power supply voltage and frequency designated in the nameplate label or in the instruction manual of this instrument.**
- **When this instrument and its accessories are about to exceed the service life, they must be disposed of according to local relevant laws and regulations or the rules and regulations of the hospital.**
- **Disposable accessories only can be used for one time in case of performance reduction or cross infection.**
- **Please remove the battery from the monitor and store correctly if the monitor will be unused for long periods.**
- **After defibrillation, the monitor will resume normal operation within 10 seconds.**



Attention

- **Please install the equipment in a place that is convenient for observation, operation and maintenance.**
- **This instruction manual describes the product with all its configurations fitted. The product you have purchased may not possess some configurations or functions.**
- **Please place this instruction manual near the instrument for easy and timely reference.**
- **This instrument cannot be used at home.**
- **The use of this monitor is restricted to one patient at a time.**



















- The service life of the monitor is 5 years.

1.2 Contraindications



Don't monitor noninvasive blood pressure (NIBP) on patients with sickle cell disease.

1.3 Equipment Symbols





Instrument Symbols

	Caution		Adult
	Neonate		Pediatric
	Type BF application		Date of manufacture
	Input/output		Serial number
	Non-invasive blood pressure		Equipotential
	Battery charging indicator lamp		On/Off key
	Reset key		AC power (AC)
	Refer to instruction manual/ booklet NOTE On ME EQUIPMENT		Conformité Européenne Complies with medical device directive 93/42/EEC
	European community representative		Manufacturer

Safety

<p>IPX1</p>	<p>Protection against vertically falling water drops</p>		<p>No alarm system</p>
	<p>Separate collection for electrical and electronic equipment</p>		

Packaging Symbols

	<p>Up</p>		<p>Limit of stacking layers</p>
	<p>Fragile</p>		<p>Keep dry</p>

Chapter 2 General

2.1 Product Introduction

2.1.1 Composition

The monitor is mainly comprised of host machine, noninvasive blood pressure cuff, blood oxygen sensor and infrared ear thermometer.

2.1.2 Intended Application

The monitor is intended for measuring patient physiological parameters such as noninvasive blood pressure (NIBP), pulse oxygen saturation (SpO₂), body temperature (Temp), and pulse rate (PR). The monitor message can be displayed, reviewed and stored but not printed.

It can be used in a medical ward, surgical ward, clinic and emergency triage department.

The recommended operator position is about one meter around the monitor in normal use.

2.2 Overview of the Monitor

This instrument features a 6-inch LED screen, and is operated by function keys on the front of the monitor. The basic functions of the monitor are shown in Figure 2-1:

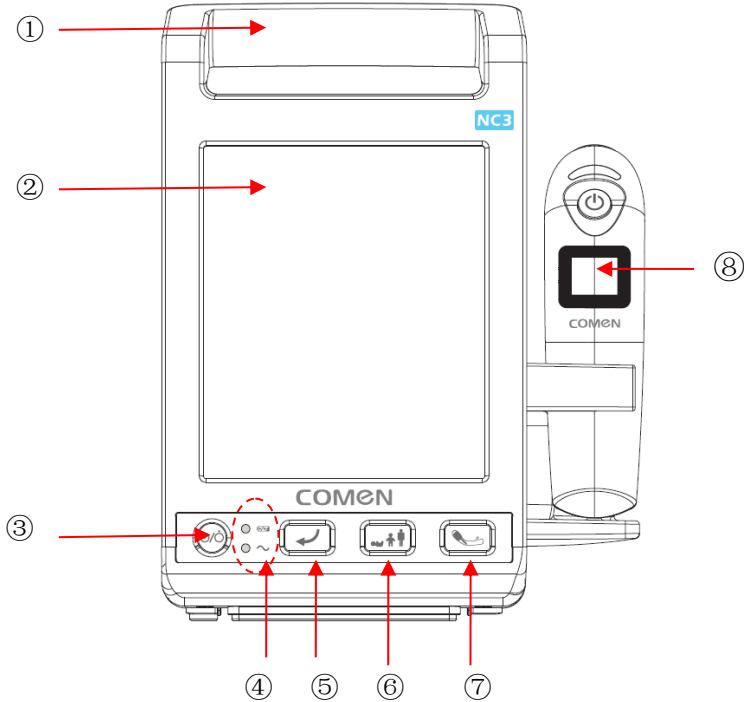





Figure 2-1 Overview of the Monitor

①	Portable handle
②	Display screen
③	On/off key (with backlight)
	Indicator lamp (from top to bottom: Battery indicator lamp, AC power indicator lamp)
	Battery indicator
	➤ ON: Monitor is equipped with battery and is connected to the AC power supply
④	➤ OFF: Monitor is not equipped with battery
	➤ Flashing: The battery is discharging
	AC power indicator lamp
	➤ ON: Monitor is connected to the AC power supply
	➤ OFF: Monitor is not connected to the AC power supply
⑤	Reset key, see the contents of “key functions” for more details
⑥	Key for switching patient category

⑦	Start/stop key for NIBP measurement
⑧	Infrared ear thermometer

2.2.1 Key Functions

Basic operations can be done using the keys listed in the table below:

Key	Description
	<p>(Reset key)</p> <ul style="list-style-type: none"> ➤ Press this key, parameters are displayed and defect codes will be cleared in measurement mode ➤ Long press this key in measurement mode to enter the parameter setting mode or review mode ➤ Press this key in 10s after boot self-checking to enter maintenance mode
	<p>(Patient type key)</p> <ul style="list-style-type: none"> ➤ Press this key to switch patient type in measurement mode ➤ Press this key to review measured data in review mode ➤ Press this key, maintenance functions can be performed in maintenance mode
	<p>(Start/Stop Key for NIBP Measurement)</p> <p>Press this key to inflate the cuff and then start NIBP measurement; if you want to stop the measurement, press this key to stop measurement and then deflate.</p>
	<p>(ON/OFF Key)</p> <ul style="list-style-type: none"> ➤ Press this key for 2s to start the instrument (the backlight turns green) ➤ Long press this key to turn off the instrument (the backlight turns off) ➤ Press this key to enter standby mode if there are no measurements being taken (the backlight turns yellow)

2.3 External Interface of the Monitor

2.3.1 Left Panel

The following sensor connectors are provided on the left panel of the monitor, shown as follows:

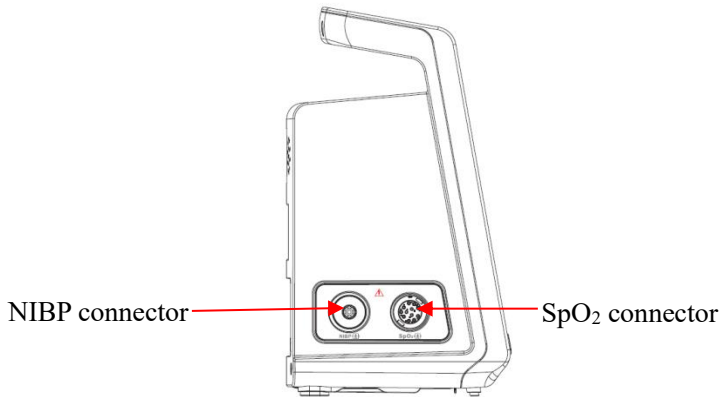

Figure 2-2 Left Panel

2.3.2 Right Panel

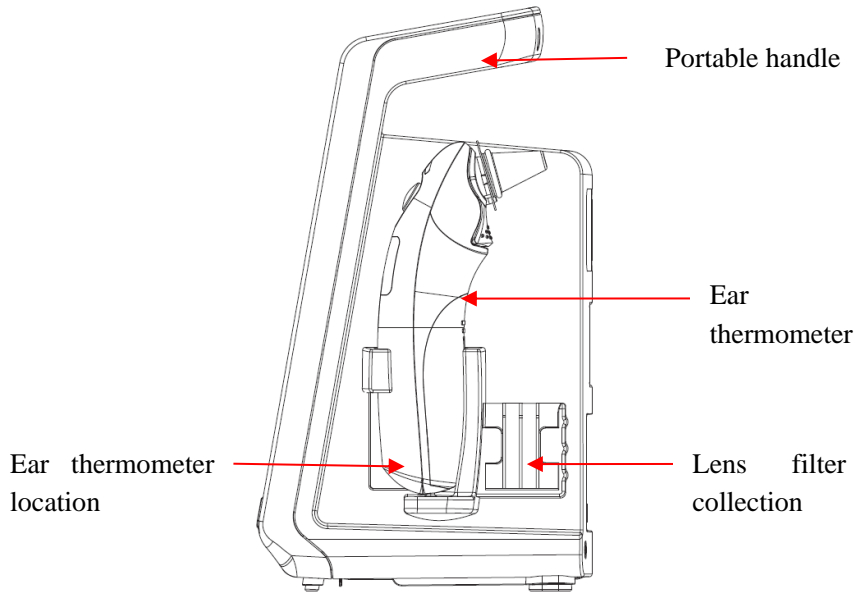

Figure 2-3 Right panel

2.3.3 Rear Panel

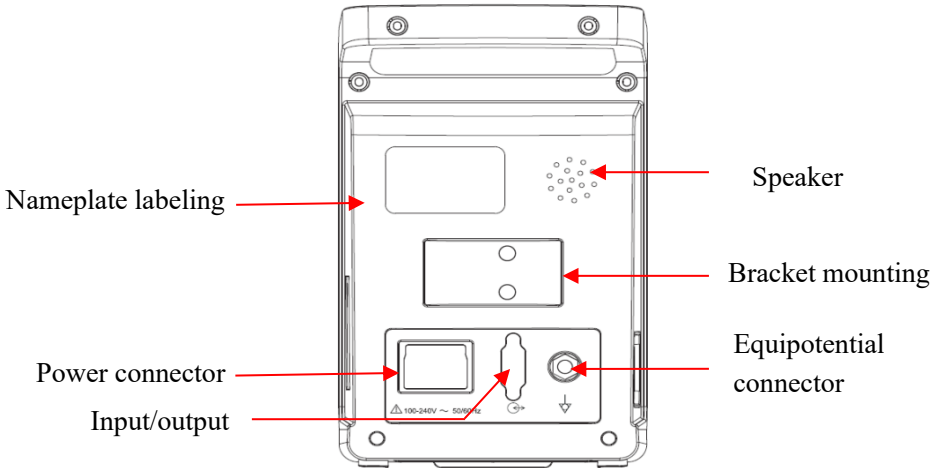

Figure 2-4 Rear panel



Warning

- **All simulation and digital equipment connected to this monitor must be certified to the designated IEC standards (e.g. IEC 60950 Data Processing Equipment Standard and IEC 60601-1 Medical Equipment Standard). Moreover, all configurations shall abide by the content of the valid edition of IEC 60601-1 System Standard. Connect additional equipment to the staffing medical system at the input/output signal port and confirm whether the system conforms to the IEC 60601-1 Standard. If you have any question, please contact the supplier.**
- **Do not touch the signal I/O ports if in contact with the patient, otherwise patient injury may result.**
- **When the signal connectors like patient cable interface and network interface are simultaneously connected with multiple-equipment, the total leakage caused cannot exceed the tolerance.**
- **The infrared ear thermometer only communicates with monitors of Comen.**

2.3.4 Base Cover

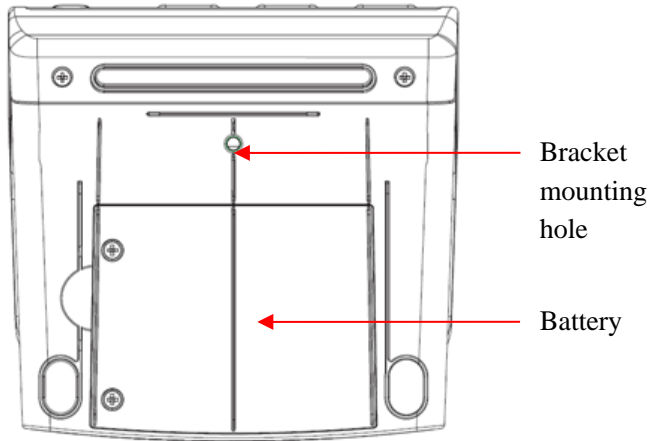

Figure 2-5 Base Cover

2.4 Screen Display

This monitor adopts a 6-inch LED screen and simultaneously displays the patient parameters, fault information, clock, battery and other messages, etc.

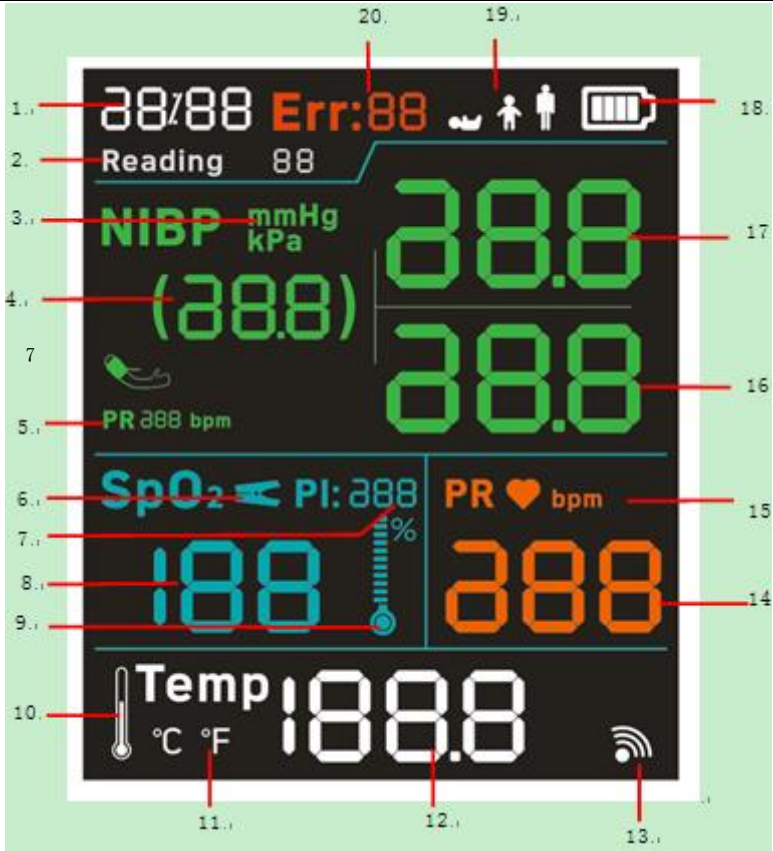

Figure 2-6 Standard Interface

1. System time

You can set, in turn, Year, Month, Date, Hour, Minute and Second as necessary.

2. Historical patient's measurement data for reviewing

The latest 50 sets of data can be reviewed.

3. NIBP unit: mmHg or kPa

4. Mean blood pressure (measurement data)

Or Cuff pressure (the cuff pressure during leak detection or pressure calibration)

5. PR value

6. Probe checking indicator

If using Comen SpO₂:

- Icon flashing indicates the finger is poorly connected or probe is disconnected

If using Masimo or Nellcor SpO₂

- Icon turning off indicates the probe is disconnected
- Icon flashing indicates the finger sensor is poorly connected.

7. Perfusion index (only for Masimo SpO₂)

8. SpO₂ measurement value

9. Pulse strength indicator

10. Temp measurement Symbol

11. Temp unit (°F, °C)

12. Temp measurement value

13. Ear thermometer wireless connection indicator

ON: Ear thermometer wireless connection is normal

OFF: Ear thermometer wireless connection is discontinued

14. SpO₂ pulse rate

15. PR measurement symbol and unit

16. Diastolic blood pressure (low pressure)

17. Systolic blood pressure (high pressure)

18. Battery indicator: See the contents of “Battery” for more details

19. Patient category (neonate, pediatric, adult)

20. Fault code: Each fault message corresponding to a fault code. See the contents of

“Fault Codes Information” for details.

Chapter 3 Installation of the Monitor



Warning

- **The equipment shall be installed by personnel authorized by Comen Company.**
- **Do not open the shell of this instrument to avoid the possible electric shock hazard. The maintenance and upgrading of this monitor must be conducted by service personnel trained and authorized by Comen Company.**
- **The software copyright of the equipment is solely owned by Comen Company. No organization or individual shall resort to modifying, copying, exchanging it or carry out any other procedure on it in any form or by any means without due permission.**
- **All the simulation and digital equipment connected with this monitor must be the products certified by the designated IEC standards (e.g. IEC 60950 Data Processing Equipment Standard and IEC 60601-1 Medical Equipment Standard). Moreover, all configurations shall abide by the content of the valid edition of IEC 60601-1 System Standard. Connect the additional equipment to the staffing medical system at the input/output signal port and confirm whether the system conforms to the IEC 60601-1 Standard. If you have any question, please contact the supplier.**
- **If it is not evident from the equipment specifications whether particular combination is hazardous, for example, due to summation of leakage currents, consult the manufacturers or else an expert in the field, to ensure the necessary safety of all devices concerned will not be impaired by the proposed combination.**



Attention

- **To ensure that the monitor works properly, please read the information in this chapter, security information and patient safety chapters before using, and install monitor as required.**

3.1 Unpacking and Examination

Carefully unpack the monitor and accessories from the box, and save the packaging materials for later transport or storage. Please check the accessories according to the packing list. Check if there is any mechanical damage. Check all the external wires, insert any accessories as required. If there are any questions, please contact our sales department or agency immediately.



Warning

- **The disposal of packaging materials shall comply with the local laws and regulations or the waste disposal rules and regulations of the hospital. The packaging materials must be kept away from children.**
- **The monitor might be contaminated during storage and transport. Please verify whether the packages are intact before use, especially the packages of single use accessories. In case of any damage, do not apply it to patients.**

3.2 Environmental Requirements

The operating environment of the monitor must meet the requirements specified in this manual.

The environment where the monitor is used shall be reasonably free from noises, vibration, dust, corrosive, flammable, and explosive substances. If the equipment is installed in a cabinet, sufficient space in front and behind shall be left for convenient operation, maintenance and repair. Moreover, to maintain good ventilation the

equipment shall be at least 2 inches away from the inside walls of the cabinet.

When the equipment is moved from one place to another, condensation may occur as a result of temperature or humidity difference. In this case, never start the system until the condensation has dispersed or evaporated.



Warning

- **Put the monitor in a place which is easy to be observed, operated and maintained.**
- **Keep the instruction manual near the monitor for convenience of use.**
- **Make sure that the operating environment of the equipment meets the specific requirements. Otherwise unexpected consequences, e.g. damage to the equipment, could result.**
- **Do not use this instrument at the place where there are flammable articles such as flammable anesthetic to prevent explosion or fire from happening.**
- **An electromagnetic field will affect the performance of this instrument, so the use of the other equipment near this instrument must meet corresponding EMC requirements. For example: Mobile phones, X-ray or MRI equipment may be an interference source, because they will transmit high-strength electromagnetic radiation.**
- **Before the instrument is switched on, please confirm whether the power supply used meets the requirements for power supply voltage and frequency designated in the nameplate label or in the instruction manual of this instrument.**

3.3 Connect the AC Power Cable

Confirm that the AC power supply meets the following specifications: 100-240V~, 50/60Hz.

Use the power cable provided with the monitor. Plug the power cable into the mains power supply socket and insert the other end of the power cable into the power connector on the monitor.



Attention

- **Plug the power cable to the dedicated hospital outlet.**
- **If a battery is provided, you must charge the battery after transport or storage of the instrument. If you turn on the monitor without connecting the AC power supply, it will probably not work because of insufficient battery power. The battery will be charged as long as AC power is connected.**

Connect the equipotential grounding wire when necessary. Refer to the content of equipotential grounding in the chapter “Patient Safety”.

3.4 Battery

A built-in rechargeable battery is installed in the medical monitor, when the power suddenly turns off, the system will be automatically powered on by the battery.

Battery installation:

The battery slot locates at the bottom of the monitor; please see the contents of “Battery” chapter for more details.

Battery charge:

When connected to the AC power supply, the battery will be automatically recharged, whether the unit is in an ON or OFF position, until the battery is fully charged.

The battery indicator turns green when the battery is charging; the battery icon shown on the screen indicates the current battery level.



Attention

- **It is recommended that the Monitor battery should be kept charged in case AC power is unavailable after a long storage or the battery is run down; otherwise, the monitor might not operate due to low power. The monitor battery can be charged despite it is powered on or not.**

3.5 Connecting Accessories

Please refer to the chapter of each measurement for connecting accessories.

3.6 Power On/Off

3.6.1 Check before Power on

Check the following before you start to make measurements:

■ Environment

Check whether there is any other electrical equipment in the surrounding, such as electric surgical equipment, ultrasound machines and radiation machines, etc. These devices might cause interference, please turn them off if necessary.

■ Power supply

Before the instrument is turned on, please confirm whether the power supply used meets the requirements and the connection is firm.

The Monitor shall be used with a protective grounding power socket.

■ Connecting accessories

Make sure all the external cables, plug-ins and accessories are properly connected.

3.6.2 Power on

After finishing the installation and check, you can start the monitor and measure the parameters.

1. Plug the power cable into the AC power supply. If you run the monitor on battery, ensure that the battery is sufficiently charged.
2. Press “” for 2s

After the system self-test the monitor sounds an audible beep. The start-up screen is displayed, and then monitor enters into the main screen.

All segments of the main screen LED display, and all LED indicator lights will be lit during the system self-test. (Refer to figure 1-2 standard interfaces). If any LED segment or LED indicator light fails to illuminate, please restart. If the problem is not solved, please do not use the monitor and contact with the manufacturer for maintenance.



Warning

- **If you find any signs of damage to monitor functions, or an error message, do not use this monitor for patient monitoring. Please contact the biomedical engineers of your hospital or maintenance engineers of the Company.**

3.6.3 Power off

To turn off the monitor follow the steps blow,

1. Ensure the monitoring is finished;
2. Disconnect all accessories from patients;
3. Long press , then the monitor will be shutdown



Caution

- **If the monitor can't be turned off or in an emergency, you can press and hold «  » more than 10s to force a shutdown. But it is not suggested as some measurement data might be lost.**
- **Upon restarting, the monitor will automatically restore to the previous setting after powering off.**

Chapter 4 Patient Safety

4.1 Safety Instruction

The design of the Vital Signs Monitor complies to international safety standards of medical electrical equipment.

4.2 Environment

The following guidance should be observed in the interest of absolute safety of electrical installations.

Vibration, dust, corrosives, explosive gas, extreme temperature and humidity should be avoided in the environment where the monitor is used.

If the Monitor is installed in a cabinet, enough space in front and behind should be left for convenient usage, maintenance and repair. The monitor should be at least 2 inches or 5 centimeters away from the walls of the cabinet for good ventilation.

The monitoring system should be kept and operated in the environmental conditions suggested in Appendix III, an ambient environment out of this range may impair the instruments accuracy and cause damage to its components and circuits.

4.3 Grounding Protection

To protect patients and operational staff, the housing of the monitor must be grounded. The monitor is equipped with a removable three-wire power cable. When the cable is plugged into a matching plug connector, the grounding wire of the power cable grounds the monitor. In case a three-plug connector is not available, the electrical

operating staff should be consulted.



Warning

- **Replacement of the three-plug connector with a two-plug connector is strictly prohibited.**

The grounding lead should be connected with the equipotential grounding terminal of the instrument. If the instrument users are unsure or do not know whether a given combination of instruments may cause electrical hazards, e.g. due to accumulations of leakage currents, the users should consult relevant manufactures or experts in this field so as to guarantee that the required safety of the combined instruments are not compromised when any given combinations of instruments are in use.

4.4 Equipotential Grounding

The primary protection of the instrument comes from the building protective grounding (protective ground) system by means of power plugs grounding. The monitor should be separately connected with the equipotential grounding system when examining hearts or skulls. One end of the equipotential grounding lead (potential equalizing lead) should be connected to the equipotential grounding terminals on the rear panel of the instrument and the other end should be connected to a connector of the equipotential system. The equipotential grounding system should be in place for safety functions of the protective grounding lead in case of any damage to the protective grounding system. Cardiac or brain examinations should be conducted only in rooms equipped with protective grounding systems. A check of the instruments should be conducted to guarantee the instruments are in good repair before each examination. The cables connecting with patients and instruments should be checked for not having been subjected to electrolytic contamination, corrosion or damage.



Warning

- **Battery power should be used to power the monitor against unstable protective grounding (protective earthing) system.**



Note

- **If the use of the instrument is affected by equipotential grounding, contact the Company's After-Sales Service Department or agents.**

4.5 Condensation

Working instruments should not form any condensation. Transferring of the instrument from one room to another may cause condensation on the instrument. This is attributed to its exposure to humid air at different temperatures. Unnecessary problems can be avoided by placing the instrument in a dry place before putting it into use.

Note: Condensation is defined as coagulation of gases or liquids when cooled, e.g. water vapor when cooled is transformed into water and water when cooled into ice. The lower the temperature is, the faster condensation formed.



Warning



- **The Monitor is prohibited for use in the presence of combustible anesthetics so as to avoid any risk of explosions.**

Chapter 5 System Settings



This monitor provides multiple working modes for the user. Such as Measurement Mode, Parameter Setting Mode, Review Mode, Maintenance Mode, and Standby Mode. The following is an introduction to the modes and features.

5.1 Measuring Mode

After start, the system defaults to Measurement Mode.

- Connect the cuff to the air tubing and plug the air tubing into the NIBP connector, and press “” to start or stop NIBP measurements;
- Connect the SpO₂ sensor cable to the SpO₂ connector on the monitor to measure SpO₂;
- Install batteries into the infrared ear thermometer to measure temperature;
- After measuring one or multiple parameters, data will be automatically saved if there is no measurement in 2 minutes.
- Press “”
 1. Clear the measurement data on screen (such as NIBP.TEMP, etc) and save them for reviewing later;
 2. Clear the fault code (if any) ;
- Press and hold  to enter Parameter Setting Mode or Review Mode.



5.2 Parameter Setting Mode

- a) In Measurement Mode, press  for more than 4s to enter Parameter Setting Mode;
- b) Press  to switch pulse sound on or off.
- c) In Parameter Setting Mode, press  to enter Measurement Mode.

5.3 Review Mode

In Measurement Mode, long press  for between 2s to 4s to enter Review Mode. In this mode 50 sets of measurement data can be reviewed. The data you reviewed corresponds to the data which you saved; it can be a parameter or a combination of multiple parameters.

Reading 50

- Press  to view the next page of data;
- Press  to view the last page of data;
- Press  to return back to Measurement Mode.

Attention

- **This monitor can only display the latest 50 sets of measurement data in Review Mode, all other data will be automatically cleared by the system.**

5.4 Standby Mode

5.4.1 To enter Standby Mode

- a) Press  to enter the Standby Mode if there are no measurements being taken.
- b) The monitor will automatically enter Standby Mode if there is no user activity after 10 minutes.
- c) The monitor will be shut down if there is no user activity after 30 minutes.



Attention

- **After entering Standby Mode, any previous measurement data will be cleared.**
- **After entering Standby Mode, the screen will turn off and the on/off key backlight will turn yellow.**
- **The Monitor will exit Standby Mode and be unresponsive if the available power is too low.**

5.4.2 To exit Standby Mode

Press any key to exit Standby Mode. Under the following conditions the monitor will exit Standby Mode automatically;



- The monitor receives a signal from the SpO₂ finger sensor probe;
- Available power is too low (“” is displayed);
- The monitor receives temperature data.

5.5 Maintenance Mode

System Setting

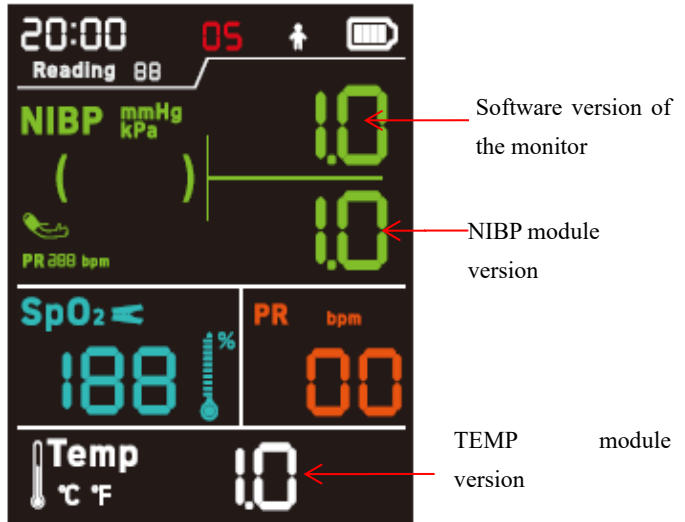
- Turn on the monitor, then press  10s after restart to enter Maintenance Mode.
- Then the NIBP module version and software version are displayed in the corresponding areas:





- Press  repeatedly to cycle through the following settings: set NIBP units, set Temp units, set system time, NIBP leak detection, NIBP pressure test, screen brightness adjustment, restore monitor to the factory default settings, and entering demo mode.
- Press and hold  to turn off the monitor, subsequently the settings above will take effect when the monitor is turned on next time.

5.5.1 Setting NIBP Units

- Enter Maintenance Mode;
- Press  and switch to NIBP units area;





- c) Press  or  to switch between the units of mmHg and kPa.

5.5.2 Setting Temp Units

- a) Enter Maintenance Mode;
b) Press  and switch to TEMP unit area;



- c) Press  or  to switch the unit: °C, °F.

5.5.3 Setting System Time

Enter Maintenance Mode;

Year:

- a) Press  and switch to 'Year' area;



- b) Press  and  to set the value.

Month/Day:

- a) Press  and switch to "Month" or "Day" area;



- b) Press  and  to set the value.

Hour/Minute:



- a) Press  and switch to “Hour” or “Minute” area;



- c) Press  and  to set the value.

After setting, press  to exit date and time settings.

5.5.4 NIBP Module Testing

- a) Enter Maintenance Mode;
- b) Press  and move the cursor to the NIBP module testing area (PR parameter display area);
- c) Press  to switch between the testing settings:
- 1) “150” stands for NIBP leak detection;
 - 2) “250” stands for NIBP pressure testing.

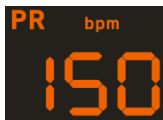



- d) Press  to start or stop test.

5.5.5 Adjusting Screen Brightness

- a) Enter Maintenance Mode;
- b) Press  and switch to brightness adjust area at the top middle of the screen.







- c) Press  or  to adjust the brightness level from 01 to 05.

5.5.6 Restore Factory Default Settings

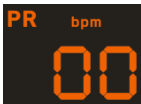
- a) Enter Maintenance Mode;

- b) Press  and switch to the restore factory default settings field;



- c) Press  to modify the setting,  indicates current configuration is not changed,  indicates restore factory default settings is the current configuration. Factory default settings cannot be changed, but if needed, factory default settings can be restored to replace the configurations made by user.

The factory default settings include:

- NIBP unit: mmHg
- Temp unit: °C
- Patient type: Adult
- Pulse sound: On





5.5.7 Demo Mode

- a) In Maintenance Mode, move the cursor to the PR area,
b) Set the value to be “200”

- c) Press the key “” to start Demo Mode.

In this mode, the monitor will not go into Standby Mode or shut down automatically even with no user activity.

5.5.8 Deleting Records

- a) Measuring Mode is default setting.
- b) In Measuring Mode, press the return button () for 2 seconds to enter into Parameter Setting Mode.
- c) In Parameter Setting Mode, press the return button () for 2 seconds to enter into Review Mode. In Review Mode, press the return button () and NIBP button () at the same time to delete all recorded data.





Chapter 6 Battery

6.1 General

A built-in rechargeable battery is installed in the monitor. When connected to the AC power supply the battery will be automatically recharged, whether the unit is in an ON or OFF position, until the battery is fully charged. In the case of power failure, the system will be automatically powered by the built-in battery thereby not interrupting the unit while working, and the indicator light for the battery will be lit after the power supply has been shut off for over 30 seconds.

The symbol “” will be shown at the bottom right corner indicating the power condition of the battery: the green indicates the power is still full or medium level, while yellow shows a low level; and red is an extremely low level, alerting the user of the condition.

The battery icon shown on the screen indicates the current battery level:

-  Indicates the battery is fully charged.
-  Indicates moderate battery power.
-  Indicates low battery power, icon flashes and the monitor gives a beep every 10 seconds, the user can press  to turn off the sound.
-  Indicates critical battery power, the icon flashes and the monitor gives a beep every 5 seconds, the sound cannot be turned off, user needs to recharge the battery immediately, otherwise the monitor will be shutdown automatically.

Working hours of a fully charged lithium-ion battery are not less than 12 hours with connected SpO₂ cable and measuring NIBP every 10 minutes in 25°C (± 5°C) environmental temperature.

**Attention**

- Please remove the battery and store it properly if not used for long periods.
- If a battery is installed, the user needs to recharge it after each use to ensure sufficient battery power.

**Warning**

- **Battery liquid is harmful.** If the liquid contacts your skin or eyes, wash it immediately with large amounts of clean water or seek medical advice.
- **Keep the battery out of reach of children.**
- **When the battery power is critically low, the monitor will give a beep every 5 seconds warning that the battery needs recharging immediately; otherwise the monitor will automatically shut down.**
- **The replacement of lithium batteries or fuel cells by inadequately trained personnel could result in a hazard.**
- **The incorrect replacement of lithium batteries or fuel cells would result in an unacceptable risk.**

6.2 Battery Charging

When connecting the AC power supply, the battery will be automatically recharged, whether the unit is in an ON or OFF position, and the indicator lamp turns green. When the battery is fully recharged, the icon  is shown and simultaneously the charging indicator lamp turns off.

Recharging time of the lithium-ion battery:

- When the monitor is turned off, the fully charged time will not be longer than 3 hours.
- When the monitor is turned on, the fully charged time will no longer than 5.5

hours.

6.3 Installing the Battery

Procedure of changing or installing the battery:

- (1) Turn off the monitor, and disconnect the power cable and any accessories.
- (2) Place the monitor with rear cover facing upwards (ensure to protect the front screen).
- (3) Unscrew the battery cover.
- (4) Unplug the used battery and take it out, and plug new battery to the connector on monitor's power panel.
- (5) Slide the new battery into the battery recess, making sure there is no squeeze on it.
- (6) Refit the battery cover and screw it in place, and turn the monitor upright.



Warning

- **Use only the supplier's designated battery.**
- **Do not remove the battery while the monitor is turned on.**

6.4 Battery usage guidance

Life expectancy of a battery depends on how often and how long it is used. For a properly maintained and stored lithium-ion battery, its life expectancy is about 3 years. For more aggressive use, life expectancy can be less. We recommend replacing lithium-ion batteries every 3 years.

For improved battery life expectancy, please read the following guidance:

- A battery performance inspection should be conducted if you suspect the battery is a source of faults. Battery inspection should also be conducted during monitor maintenance.
- When a battery is used or stored for 3 months or the operating time is significantly shorter, the optimization shall be carried out.
- Remove the battery before transporting the monitor or if the monitor will remain unused for 3 months or more.
- Before removal and storage of the battery, ensure it has at least 50% charge, and that at least 6 months shelf life remains. If the battery is to be stored for 6 months or longer, fully discharge the battery first before storage.
- Ensure the storage environmental temperature is around 15°C and that there is no contact with metal objects during storage otherwise the life expectancy of the battery will be noticeably shorter.

6.5 Conditioning the battery and Checking Battery

Performance

(1) Conditioning the battery

When the battery is used for the first time at least two complete battery conditioning cycles should be carried out. A complete conditioning cycle should be: uninterrupted battery charging until the battery icon shows fully charged followed by use until the battery is fully discharged and monitor is automatically turned off.

Process to condition a battery:

- (a) Disconnect the monitor from the patient and suspend all monitoring and measuring procedures.

- (b) The battery should remain in the monitor.
- (c) Allow the battery to be charged uninterruptedly until it is fully charged. Please refer to Appendix III for more information about the duration of charging.
- (d) Disconnect the AC power supply, the monitor will then be on battery power only until the battery runs out and the monitor will automatically turn off.
- (e) This completes the battery conditioning process.

(2) Checking Battery Performance

The service life of battery is changeable along with its storage, working environment charge cycles and service time. Even though a battery is not being used, its performance will gradually deteriorate.

Procedure for checking the battery is as follows:

- (a) Disconnect the monitor from the patient and suspend all monitoring and measuring procedures.
- (b) When charging the battery, at least six hours of charging should be ensured until it is fully charged.
- (c) Disconnect the AC power supply, power on the monitor with the battery until it is fully discharged and the monitor shuts off automatically. Record the duration.
- (d) The period of battery discharge will reflect the battery performance.
- (e) Once the discharge period is down to 50% of the original time, it requires changing the battery.



Attention

- **In order to extend the service life of the battery it is recommended to charge it every three months after a long dormant period so as to prevent over discharge.**
- **Battery power supply loss depends on the configuration and operation of the monitor; for example, the unit will have a big loss of battery power if it is often used to measure the NIBP parameter.**

6.6 Battery Recovery

If the battery shows apparent damage or cannot be charged, it should be exchanged immediately, and the old battery should be recovered and properly disposed of in accordance with relevant laws or rules and regulations for hospitals.



Warning

- **Do not open the batteries, or dispose of them in fire, or cause them to short circuit. They may explode, leak or heat up, causing personal injury.**

Chapter 7 Cleaning and Disinfection

Use only materials and methods listed in this chapter, that are approved by the company, to clean or disinfect the equipment. The company does not provide any warranty if damage is caused by use of unapproved materials or methods.

The company assumes no responsibilities for the effectiveness of the listed chemicals or methods as a means of controlling infection. For information on how to control infection, please consult your hospital's infection prevention department or epidemiologist. Also see all local policies for your hospital and country.

7.1 Overview

This chapter describes the cleaning and disinfection methods of the monitor and some accessories. For the cleaning and disinfection methods of other reusable accessories, please refer to the attached random file.

Please keep your device and accessories dust free. After cleaning, please check the equipment carefully. If you notice any signs of aging or damage, stop using it immediately. If you need to return the device to Comen for repair, please clean it first.

Please observe the following notes:



Warning

- **Use only cleaning agents and disinfectants recommended in this user manual. Using other cleaning agents and disinfectants can damage the device or cause a safety hazard.**
- **The power must be turned off and the AC power supply disconnected before cleaning the monitor.**
- **Do not use EtO (ethylene oxide) to disinfect the monitor.**
- **Do not leave disinfectant on any surface or accessories of the monitor. If there is any disinfectant residue, wipe it off with a damp cloth.**
- **Cleaning agents should not be mixed, or hazardous gases may be produced.**
- **This section only describes how to clean reusable accessories. Disposable accessories cannot be cleaned and must not be**

reused, to avoid cross-contamination.

- **In order to protect the environment, disposable accessories must be recycled or properly disposed.**
- **After cleaning, if there is damage or aging signs on the sensor cable, replace the cable with a new one.**
- **Do not conduct high temperature sterilization of the monitor and any of its accessories.**
- **Do not use any cleaning solutions other than those recommended here, as this may permanently damage the device, sensors, and cables.**
- **Do not immerse the sensor or connector in any solution for cleaning or disinfecting.**



Caution

- **If you accidentally pour liquid on the equipment or accessories, please contact our service person or Comen immediately.**
- **If the equipment gets accidentally wet, immediately place the equipment in the ventilated area, and then contact our service person or Comen immediately.**

7.2 Cleaning and Disinfection of the Monitor

The monitor should be kept clean. It is recommended to clean the outer surface of the monitor housing frequently, especially in areas with a harsh environment or heavy wind and sand, in which case cleaning frequency should be increased. Before cleaning, please consult or understand the hospital's regulations on equipment cleaning.

Cleaning steps:

- 1) Turn off the power and disconnect the power cable first.
- 2) Use a soft cloth, absorb an appropriate amount of cleaning agent, and then wipe the housing of the monitor, power cable and the infrared ear thermometer.
- 3) Use a soft cloth, absorb an appropriate amount of cleaning agent, and then wipe

the screen of the monitor.

- 4) Use a soft dry cloth to wipe off excess cleaning agent.
- 5) Place the device in a cool, ventilated environment to dry.

Disinfection may cause a certain degree of damage to the monitor. It is recommended that the device is disinfected only when necessary as per the hospital maintenance program.

Optional cleaning agents and disinfectants:

Parts to be cleaned/disinfected	Cleaning agents and Disinfectants
Housing of monitor	Ethanol (75%±5), Isopropyl alcohol (70%),
Screen of the monitor	Glutaraldehyde (2%), Sodium hypochlorite (2.5%), Hydrogen peroxide (2.7%~3.3%)

7.3 Cleaning and disinfection of accessories

Before cleaning, please consult or understand the hospital's regulations on equipment cleaning. It is recommended that the accessories are disinfected only when necessary as per the hospital maintenance program. Clean the accessories before disinfection.

7.3.1 Cuff Cleaning and Disinfection

Our recommended cleaning and disinfectants are Ethanol (75%±5), Isopropyl alcohol (70%), Glutaraldehyde (2%), Sodium hypochlorite (2.5%), Hydrogen peroxide (2.7%~3.3%).

The air bag must be removed before cleaning.

The cuff can be disinfected by wiping with a moist cloth dampened with cleaning agents. Cleaning can extend service life. The air bag can be wiped by a moist cloth dampened with water. Naturally dry it after cleaning.

The cuff can be disinfected by wiping with a moist cloth dampened with disinfectant. Long-term use of disinfectants may cause color fading and discoloration.



Warning

- Do not squeeze the rubber tube of the cuff.
- When cleaning, only wipe the outer circumference of the connector socket, and not the inside.
- When cleaning the bladder, take care not to allow any liquid to enter the bladder.
- The cuff should not be dry cleaned.

After cleaning, please reinstall the bladder into the cuff as follows.

- 1) To reinstall the bladder into the cuff, first place the bladder on the front end of the cuff so that the rubber tube is lined up with the large opening at the long end of the cuff.
- 2) Then roll the bladder longitudinally and insert it into the large opening of the cuff. Hold the tube and cuff and shake the entire cuff until the bladder is in place.
- 3) Introduce the tube into the cuff and pass it through the small hole. See below:

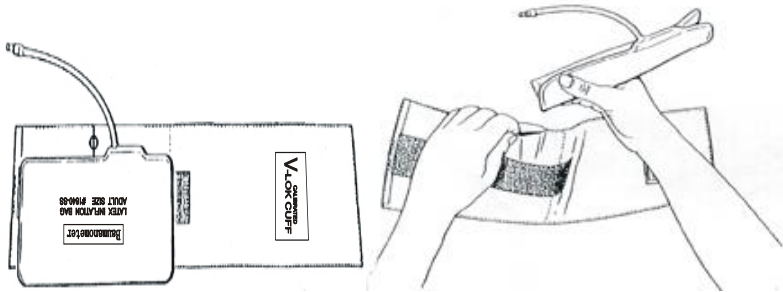

Figure 7-1 Replace Tape in the Cuff

7.3.2 Cleaning and disinfection of other accessories

Cleaning steps:

Cleaning and Disinfection

- 1) Use a soft cloth, absorb an appropriate amount of cleaning agent, and then wipe the accessories.
- 2) Use a soft dry cloth to wipe off excess cleaning agent.
- 3) Place the accessories in a cool, ventilated environment to dry.

Optional cleaning agents and disinfectants:

Parts to be cleaned/disinfected	Cleaning agents and Disinfectants
SpO ₂ sensor	Ethanol (75%±5), Isopropyl alcohol (70%), Glutaraldehyde (2%),
Blood pressure catheter	Sodium hypochlorite (2.5%), Hydrogen peroxide (2.7%~3.3%)

Chapter 8 Maintenance

8.1 Maintenance and Safety Check

The overall checking of the monitor, including a safety check, should be performed only by qualified personnel before first use, every 6 to 12 months, and each time after repair.

Before using the monitor, do the following:

- (a) Check the work environment and if the power supply meets the requirements.
- (b) Check if there is any mechanical damage.
- (c) Check if the cables are worn and ensure insulation is in a good condition.
- (d) Check all the functions of the monitor to make sure that the monitor is in a good condition.
- (e) Check if the accessories used are specified by the manufacturer.
- (f) Check the battery.
- (g) If the monitor is equipped with a recorder, please check if the recorder is normal and recording paper meets the specified requirement.
- (h) Check if the wiring resistance and leakage current meet the requirements.

If you find any damage on the monitor, stop using the monitor on patients, and contact the biomedical engineer of the hospital or our Customer Service immediately.

All the safety and maintenance checks carried out before using the monitor should be performed by a qualified customer service technician. Maintenance and Safety Checks

carried out by non-trained or unauthorized individuals can cause the monitor damage or cause a security risk, and human health may be endangered.

The circuit diagrams of the monitor can be provided by the manufacturer, Comen Company, as per customers requirements. Qualified technicians can use them to help the user repair some apparatus that Comen Company classifies as “can be maintained by the user”.



Warning

- **If the hospital or agency that is responsible for using the monitor does not follow a satisfactory maintenance schedule, the monitor may become damaged, and human health may be endangered.**

8.2 Maintenance Schedule

The following safety and maintenance checks can be conducted by professional persons from Comen Company. You can contact with our customer service technicians if you need the following maintenance checks. Before the inspection or maintenance, the instrument should be cleaned and disinfected.

Check and maintenance	Frequency
According to IEC 60601-1 Medical electrical equipment Part 1 General requirement for safety	Check can be conducted at least every 2 years. Or after monitor is accidentally dropped, power replacement, or when needed by customers
NIBP air leakage check	Check can be conducted at least every 1 year or when needed by customers.
NIBP adjustment	Check can be conducted at least every 1 year or when needed by customers.
NIBP pressure calibration	Check can be conducted at least every 1 year

	or when needed by customers.
Battery	See the Battery section for details



8.3 NIBP Air Leakage Check

The NIBP leakage test checks the integrity of the system and the valve. It is required at least once a year or when you doubt the measured NIBP. If the test is passed, the “P” will be shown in mean pressure area; if not, there will be a corresponding error prompt in the NIBP information area.

Tools required:

- An adult cuff
- An air tube
- A correctly sized cylinder

Follow this procedure to perform the leakage test:

1. Press “” set the patient type to adult “” ;
2. Connect the cuff to the air tubing and connect the air tubing to the NIBP connector on the monitor;
3. Wrap the cuff around the cylinder as shown below

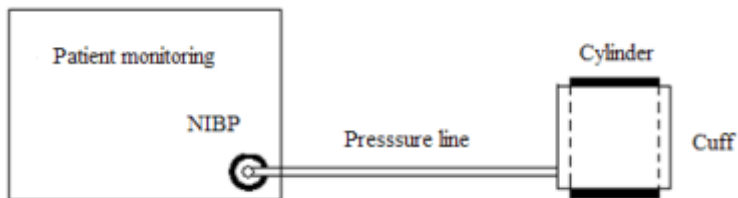





Figure 8-1 NIBP Air Leakage Check Connections

4. Enter Maintenance Mode following the steps shown in Section 5.5, press  and observe the NIBP module interface, the PR parameter area prompts “150”.



5. Press , to start leakage test. The real-time pressure is shown in mean pressure area.
Press  to stop the test if necessary.
6. After the test is completed, the monitor will automatically deflate the cuff.
7. If **P** is shown in fault code area that means the test is passed, if **F** is shown, it indicates that the NIBP airway may have leakages. Check the tubing and connections for leakages, and perform a leakage test again.



Warning

- **This leak detection is different from those described in the standard EN 1060-1, which is for users to simply test air leakage in NIBP inflation. If the system displays that the NIBP is leaking at the end of testing, please contact the Comen company maintenance engineers.**

8.4 NIBP Pressure Calibration

NIBP pressure calibration is required at least once a year or when you doubt the measured NIBP.

Tools required:

- T-piece connector
- Appropriate air tubing
- Hand pump

- Metal Vessel (500±5% ml)
- Reference manometer (calibrated with higher than 0.75mmHg accuracy)

Follow this procedure to perform the test:

1. Connect the equipment :

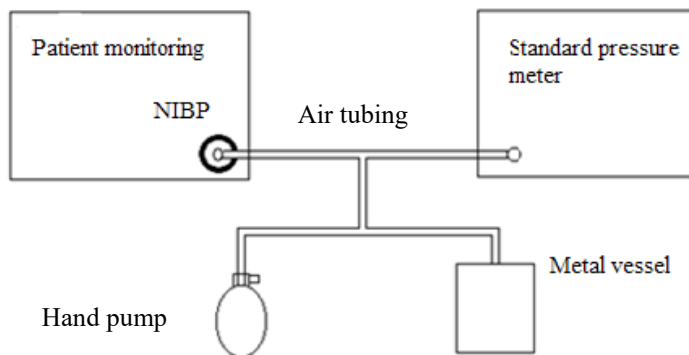

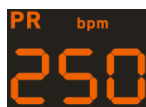



Figure 8-2 Connections to perform NIBP Calibration

2. Before inflation, the reading of the manometer should be 0. If not, disconnect the airway and reconnect it until the reading is 0.
3. Enter Maintenance Mode, press  and switch to detection interface of the NIBP module, “250” is shown in the PR parameter area.



4. Press  to start the test. The real-time pressure is shown in mean pressure area.
- Press  to stop the test if necessary.
5. Raise the pressure in the metal vessel to 50mmHg with the hand pump then stop and hold for 10s to make the value stable.
6. Compare the manometer values with the displayed values. The difference between

the manometer and displayed values should be no greater than 3mmHg.

7. Raise the pressure in the metal vessel to 200mmHg with the hand pump then stop and hold for 10s to make the value stable. Repeat step 6.

If the difference between the manometer and displayed values is greater than 3 mmHg, contact your service personnel.

8.5 Calibrating NIBP

NIBP overpressure protection is not user-calibrated. The cuff pressure transducer must be verified and calibrated once a year by a qualified service professional. Contact your service personnel when it is necessary.

Chapter 9 SpO₂ Monitoring

9.1 General

The monitor measures blood-oxygen saturation, that is, the percentage of the total oxyhemoglobin.

Pulse oximetry is a measurement of oxygen saturation. It is a continuous, non-invasive way of determining the hemoglobin oxygen saturation. It is involved in measuring how much light emitting from the sensor side passes through the patient's tissue (such as a finger or an ear) and then reaches the other side of the receiver.

The monitor provides for measurements:

- Oxygen saturation of arterial blood (SpO₂): Percentage of oxygenated hemoglobin in relation to the sum of oxyhemoglobin and deoxyhemoglobin (functional arterial oxygen saturation).
- Pulse rate: Detected pulsations per minute.
- Perfusion index: Numerical value for the pulsatile portion of the measured signal caused by arterial pulsation.
- Pulse strength indication: The wavelength range and maximum light output power of different sensors are particularly useful to clinicians, for photodynamic therapy.
- ◆ The Comen SpO₂ module sensor can measure wavelengths: red light 660nm, infrared light 905nm.
- ◆ The Masimo SpO₂ module sensor can measure wavelengths: red light 660nm, infrared light 905nm.
- ◆ The Nellcor SpO₂ module sensor can measure wavelengths: red light 660nm, infrared light 900nm.
- ◆ The sensor's maximum light output power is less than 15 mW.

**Warning**



- **If there is carbonyl hemoglobin, methemoglobin, or dye dilution chemical present, the SpO₂ value will be effected.**

9.2 SpO₂ Contraindications

1. Do not apply an SpO₂ sensor on the same spot for a long time.
2. Do not apply an SpO₂ sensor to patients allergic to rubber material.

9.3 Identifying the SpO₂ Sensor

To identify which brand SpO₂ sensor should be connected to your monitor, check the symbol located at the side of monitor:

- Comen SpO₂ module: no symbol
- Masimo SpO₂ module:  MasimoSET.
- Nellcor SpO₂ module:  Nellcor

The three kinds of SpO₂ probe interfaces are incompatible with eachother.

**Warning**

- **This monitor can automatically identify the SpO₂ sensor. However, as the internal hardware has been configured at the factory, the use of improper SpO₂ sensor will lead to wrong measurement values.**

9.4 Safety Information

**Warning**

- **First check whether the sensor cable is normal before the monitor is started. When you unplug the SpO₂ sensor from the connector on the monitor, the screen will display a fault code.**
- **If any damage is found either on the accessories or the packaging, do not**

use them and return them to the factory.

- Do not twist the SpO₂ sensor cable.
- Do not apply the sensor on limb with an arterial catheter or intravenous tube.
- Skin irritations or lacerations may occur as a result of the sensor being attached to one location for too long. To avoid skin irritations and lacerations, periodically inspect the sensor application site and change the application site at least every two hours.



Attention

- Make sure that the nails cover the light inside the probe. Its lines should be placed on the back of hands.
- Blood oxygen simulator can only verify the function of the oxygen sensor, but can't validate the precision.
- Do not place the sensor and blood pressure cuff on the same limb while measuring, because the process of NIBP measuring may occlude the blood flow, and affect readings of SpO₂.
- There is no visual or audio alarm when the SpO₂ measurement data is abnormal, please pay close attention to the patient's condition.
- Confirmation regarding Masimo SpO₂ measurement accuracy: the accuracy of SpO₂ has been confirmed by comparison between measurements on human subjects and referential value of arterial blood measured by CO-oxygen pressure gauge. Measurement results of Pulse Oxygen Meter are subject to statistical distributions, which are, compared to measurement results by CO-oxygen pressure gauge, expected to fall in designated accuracy range with 2/3 results.
- Masimo SpO₂ has passed motion accuracy verification by a comparison of the laboratory joint photoelectric oximeter and monitoring in human blood where healthy adult volunteers' SpO₂ value are at 70% to 100% under the inducible hypoxic condition. This difference equals to \pm one standard deviation, which contains 68% of the sample.

- **Masimo SpO₂ has passed the non-movement motion accuracy verification in the human blood research where healthy adult volunteers conduct friction motion or tapping motion at 2 to 4 Hz to induce a hypoxic condition. There is no repeated movement at range from 1 to 2 cm and frequency from 1 to 5 Hz. When set at inducible hypoxic condition (SpO₂ 70% ~100%) with range from 2 to 3 cm, the results should compare those of laboratory joint photoelectric oximeter and monitor. This difference equals to \pm one standard deviation, which contains 68% of the sample.**

9.5 SpO₂ Accuracy Test



Warning

- **A functional tester cannot be used to assess the accuracy of a pulse oximeter probe.**

The recommended method of determining the SpO₂ accuracy of the monitor is to compare its SpO₂ readings with the readings of a CO-oximeter.

9.6 PR Accuracy Determination

The reference method for the computation of pulse rate accuracy is ECG heart rate.

9.7 Measuring SpO₂



Warning

- **Select the appropriate configuring instructions according to the monitor and its supporting SpO₂ sensor, which is fundamentally vital when operating on a neonate.**

- 1) Turn on the monitor;
- 2) Select an appropriate SpO₂ probe according to the SpO₂ technology type,

patient type and patient's weight;

- 3) Clean the measurement site, if necessary remove colored nail polish.
- 4) Connect the sensor to the SpO₂ cable (if an extension cable is used) and insert the cable into the SpO₂ connector on the monitor;
- 5) Attach the sensor to the appropriate location on the patient's finger;
- 6) The monitor will automatically recognize the probe, and display the SpO₂ data and PR.

Adult/Pediatric SpO₂ sensor:

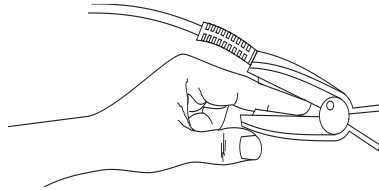

Figure 9-1 Installation of the sensor

Neonatal SpO₂ sensor

- A Neonatal oxygen probe consists of the Y-shaped blood-oxygen probe and neonatal oxygen probe sheath. Insert the LED side of the Y-shaped probe in the upper groove of the sheath, and respectively the PD side of the probe within the lower (See Figure 9-2), then the neonatal blood-oxygen probe as shown in Figure 9-3.

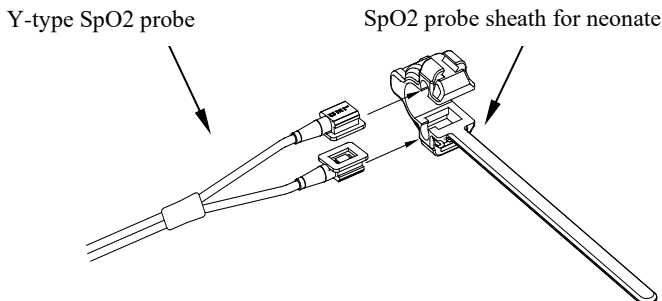

Figure 9-2 Neonatal SpO₂ sensor (1)

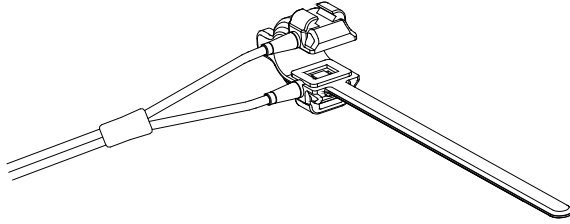

Figure 9-3 Neonatal SpO₂ sensor (2)

- Placement of the neonatal blood-oxygen probe

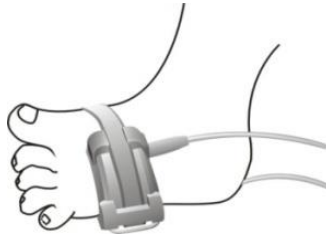

Figure 9-4



Attention

- Intravenous dyes such as methylene blue, or intravascular dyshemoglobins such as methemoglobin and carboxyhemoglobin may lead to inaccurate measurements.



Warning

- Inspect the application site every two hours to ensure skin quality and correct optical alignment. If the skin quality changes, move the sensor to another site. Change the application site at least every four hours.
- Using an SpO₂ sensor during MR imaging can cause severe burns. Minimize this risk by positioning the cable so that no inductive loops are formed. If the sensor does not appear to be operating properly remove it immediately from the patient.

9.8 Measurement Limits

During operation, the following factors can affect the accuracy of SpO₂ measurement:

- High-frequency radio interference, for instance, interference self-generated from the host system or from electrical scientific instruments connected to the system.
- During magnetic resonance imaging scanning (MRI), do not use the photoelectric oximeter and oxygen sensor, since induced currents may cause burning.
- Intravenous dye.
- Excessive Patient movement.
- External radiation.
- Improper installation of sensor or improper contact position with the application site.
- Sensor's temperature (optimal temperature should be among 28 °C - 42 °C) .
- The sensor is placed on the same limbs with a blood pressure cuff, arterial catheter, or the pipeline of body cavity.
- Concentrations of non-functional hemoglobin such as carboxyhemoglobin (COHb) and methemoglobin (MetHb) etc.
- Extremely low degree of pulse oxygen saturation.
- The measured area has poor circulation.
- Syndromes such as shock, anemia or low temperature, application of vasoconstrictor drugs and etc. can reduce blood flow to the level of not being able to be measured.

- Measurement also depends on both the oxyhemoglobin and reduced hemoglobin's absorption of specific wavelengths of light. If any other factors absorb the same wavelength, they will generate false measurement, or lower SpO₂ values. These factors are as follows: carbonization of hemoglobin, methemoglobin, methylene blue, indigo rouge. It is recommended to use only the SpO₂ probe described in the accessories.

9.9 Setting Pulse Sound

The user can switch pulse sound ON or OFF, the method is shown below:

1. Press and hold “ key to turn the sound On or Off.



indicates the pulse sound is Off.



indicates the pulse sound is On.

The setup will take effect after restart or switch to another interface by long pressing .

9.10 Display

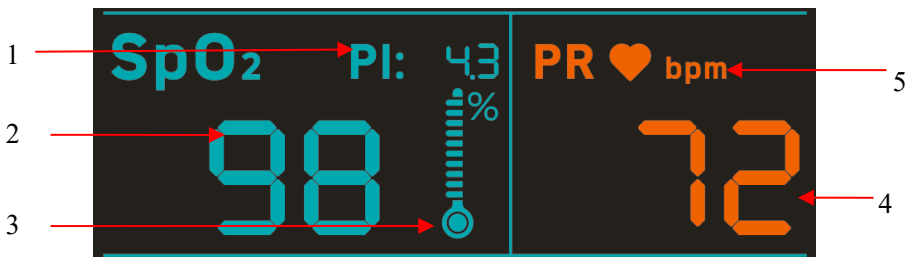

Figure 9-5 SpO₂ display

1. PI (Perfusion index): Use for Masimo SpO₂ and Comen SpO₂. Perfusion index is the

percentage of the pulsating quantity to the pulsating quantity caused by artery blood flow change in blood oxygen signal. Perfusion index is a reaction of blood oxygen signal intensity, part indicates the signal quality. It is the best while the index is greater than 1; it is acceptable when index is in the range of 0.3-1 and it is weak when less than 0.3, the probe shall be adjusted if that happens. Please verify the saturation condition in other ways if it doesn't improve.

2. SpO₂ (Arterial oxygen saturation): percentage of oxygenated hemoglobin in relation to the sum of oxyhemoglobin and deoxyhemoglobin (functional arterial oxygen saturation).
3. Pulse strength indicator: Proportional to the strength of the pulse.
4. PR (Pulse rate): detected pulsations per minute.
5. PR indicator: Indicates the heart beats.

9.11 Masimo Information



■ Masimo Patent

It contains one or more of the following U.S. patents: RE38,492, RE38,476, 6,850, 787, 6,826,419, 6,816,741, 6,699,194, 6,684,090, 6,658,276, 6,654,624, 6,650,917, 6,643,530, 6,606,511, 6,584,336, 6,501,975, 6,463,311, 6,430,525, 6,360,114, 6,263,222, 6,236,872, 6,229,856, 6,206,830, 6,157,830, 6,067, 462, 6,011,986, 6,002,952, 5,919,134, 5,823,950, 5,769,785, 5,758,644, 5,685,299, 5,632,272, 5,490,505, 5,482,036, international patents or a item or a number of patents referred to in the www.masimo.com/patents, including functions from products of Satshare ® and the U.S. Patent 6,770,028. Other patents are under application.

■ Other Information

© 2006 Masimo Corporation. Masimo, Radical, Discrete Saturation Transform, DST, Satshare, SET, LNOP, LNCS, and LNOPv are federal registered trademarks of Masimo Corporation's.

RadNet, Radicalsreen, signal IQ, FastSat, fastStart are trademarks of APOD and Masimo Corporation.

Chapter 10 NIBP Monitoring

10.1 General

The monitor uses the oscillometric method for measuring NIBP. Oscillometric devices measure the amplitude of pressure changes in the occluding cuff as the cuff deflates from above systolic pressure. The amplitude suddenly increases as the pulse breaks through the occlusion in the artery. As the cuff pressure decreases further, the pulsations increase in amplitude, reach a maximum (which approximates to the mean pressure), and then diminish.

NIBP measurement is suitable for use in the presence of electrosurgery and during the discharge of a cardiac defibrillator according to IEC80601-2-30.

It is available for adult, pediatric, neonate.



Attention

- **The effectiveness of NIBP measurement has not been established in pregnant women, including pre-eclamptic patients.**

10.2 NIBP Contraindications

1. Don't apply the NIBP cuff to skin with inflammation and ulceration or tie the cuff up for NIBP measurement.
2. Don't apply the NIBP cuff to patients that are allergic to NIBP rubber.
3. Don't use the NIBP cuff on the upper skin that shows any damage.

10.3 Safety Information



Warning

- **Inflation exerts pressure on the measurement site during NIBP measuring; therefore, the doctor should determine whether the patient is suitable to have NIBP measurements based on patient's clinical condition.**
- **Before starting the measurements, make sure the selected criteria applies to your patients (adults, pediatric, neonate). Using other than the neonatal mode on a neonatal patient may put the patient in danger.**
- **Do not use the NIBP cuff on a limb with an intravenous infusion or arterial catheter in place. This could cause tissue damage around the catheter if the infusion is slowed or blocked during cuff inflation.**
- **Too frequent measurements can cause injury to the patient due to blood interference.**
- **Ensure that the inflatable tubes that attach the blood pressure cuff to monitor are smooth and with no kinking.**
- **Do not place the cuff over a wound, as this can cause further injury.**
- **Do not apply the cuff and its pressurization on any limb where there is intravascular access or therapy, or an arterio-venous (A-V) shunt is present, as it could cause temporary interference to blood flow and result in injury to the patient.**
- **Do not place the cuff and its pressurization on the arm on the side of a mastectomy.**
- **The pressurization of the cuff can temporarily cause loss of function of simultaneously used monitoring ME equipment on the same limb.**
- **Please check that operation of the automated measurement does not result in prolonged impairment of patient blood circulation.**
- **Do not measure NIBP on patients with sickle-cell disease or any condition where skin damage has occurred or is expected.**
- **Use clinical judgment to decide whether to perform frequent unattended blood pressure measurements on patients with severe blood clotting disorders because of the risk of hematoma in the limb fitted with a cuff.**



10.4 NIBP Measurement

10.4.1 Preparation for Measuring

- a) Turn the monitor on;
- b) Verify the patient type, change it on the monitor if necessary;
- c) Connect the cuff to the air tubing;
- d) Plug the air tube into the NIBP connector on the monitor, avoid compression or restriction of pressure tube , air must pass unrestricted through the tubing;
- e) Make sure that you are using a correct size cuff and that the bladder inside the cover is not folded or twisted.
 - A wrong size cuff and a folded or twisted bladder, can cause inaccurate measurement. The width of the cuff should be 40% (or 50% for neonates) of the limb circumference, or $\frac{2}{3}$ of the length of the upper arm. The inflated part of the cuff should be long enough to encircle 50~80% of the limb;
- f) Apply the cuff to a limb at the same level as the patient's heart. If it is not, you must use the measurement formulary to correct the measurement.
 - The marking on the cuff must match the artery location. Do not wrap the cuff too

tightly around the limb. It may cause discoloration, and ischemia of extremities. Inspect the application regularly to ensure the skin quality and inspect extremity of the cuffed limb for normal color, warmth and sensitivity. If the skin quality changes, or if the extremity circulation is being affected, move the cuff to another site or stop blood pressure measurement immediately. Check more frequently when taking automatic measurements.

- If the limb is not at heart level, use the correction formula:
 - Add 0.75mmHg (0.10kPa) for each centimeter higher or 1.9mmHg (0.25kPa) for each inch higher.
 - Deduct 0.75mmHg (0.10kPa) for each centimeter lower or deduct 1.9mmHg (0.25kPa) for each inch lower.

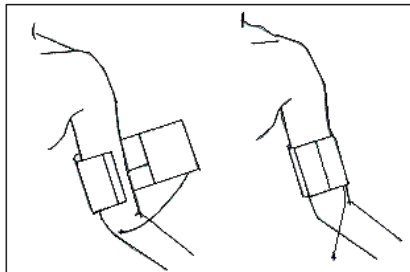

Figure 10-1 Cuff usage (Adult)



Figure 10-2 Cuff usage (Neonate)

10.4.2 Applying the Cuff

Adult/pediatric/neonate/ can use the cuffs repeatedly:

NIBP Monitoring

patient type	Limb Circumference	Cuff width	Inflatable tube length
neonate	10~19 cm	8 cm	2 m
pediatric	18~26 cm	10.6 cm	
adult1	25~35 cm	14 cm	
adult2	33~47 cm	17 cm	
leg	46~66 cm	21 cm	

Neonatal/ pediatric /adult disposable cuffs:

Size	Limb Circumference	Cuff width	Inflatable tube length
1	3.1~5.7 cm	2.5 cm	2 m
2	4.3~8.0 cm	3.2 cm	
3	5.8~10.9 cm	4.3 cm	
4	7.1~13.1 cm	5.1 cm	

10.4.3 Measurement Limitations

According to the patient's condition, oscillatory measurement has some limitations. Such measurements are looking for regular impulse waves produced by arterial pressure. In case the patients' condition makes this kind of detection difficult, measurement values become unreliable and load time increases.

(1) With Excessive and Continuous Patient Movement

If the patient is moving, shaking or in spasms, measurements will be unreliable or even impossible, as these may interfere with the detection of the arterial pressure pulse and load time will be extended.

(2) With Cardiac Arrhythmias

If the patient has shown arrhythmia caused by irregular heartbeats, measurements are unreliable or even impossible and load time will be extended.

(3) With a Heart-Lung Machine

Measurements are impossible if the patient is on a heart-lung machine.

(4) With Rapid Blood Pressure Changes

If the blood pressure is rapidly changing, measurements will be unreliable or even impossible.

(5) With Severe Shock or Hypothermia

If a patient is in serious shock or hypothermia that reduces blood flow to the peripheries, the measurements will be unreliable.

(6) Limit Heart Rate

Measurements are impossible with heart rate extremes of less than 40bpm or greater than 240bpm.

(7) With Obesity

A thick layer of fat around a limb damps oscillations from the artery, thus preventing them from reaching the cuff. The accuracy is lower than a normal limb.





(8) Hypertension Patient

In order to obtain accurate blood pressure measurement for a hypertension patient, please note the following guidance:

- During the measurements the patient should be relaxed and not talk to others.
- 5 minutes should elapse before the first reading is taken.
- the patient's position should be as follows:
 - a) Comfortably seated
 - b) Legs uncrossed
 - c) Feet flat on the floor
 - d) Back and arm supported

- e) Middle of the CUFF at the level of the right atrium of the heart

10.4.4 Starting Automatic Measurements

- 1) Press  for 2s to enter the interval setting.
- 2) Press  to select interval: 2min, 3min, 4min, 5min, 10min, 15min, 20min, 25min, 30min, 1hour and CO (continual measurement). After selecting the interval, press  to confirm. If you select CO, the monitor will start 5 minute measurements continuously.
- 3) Press  to start automatic measurements.



Attention

- **The Automatic measurement function is only available for Comen NIBP.**
- **At the end of the continuous measurement period, the equipment reverts to manual mode.**

10.4.5 Starting /Stopping Manual Measurements

You can start or stop manual measurement by pressing the  hard key on the monitor's front panel.

The default inflation pressure of this monitor is:

- Adult: 160mmHg
- Pediatric: 120mmHg
- Neonate: 100mmHg



Attention

- **If you doubt the NIBP readings, determine the patient's vital signs by alternative means and then verify that the monitor is working correctly.**

Warning

- If liquid splashes on the devices or accessories, especially when the liquid is likely to enter into the monitor, please contact the hospital's maintenance department.

10.5 NIBP Display

NIBP measurement results are displayed on the screen; the following figure is for reference only; the graphic displayed on your monitor might be different:

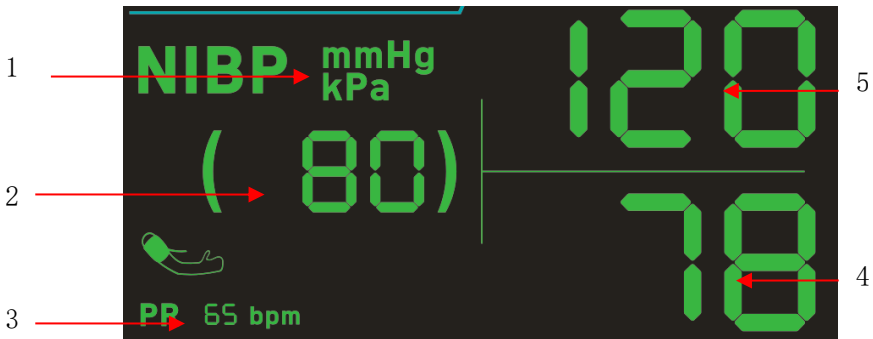

Figure 10-2 NIBP Measurement display area

1	Pressure unit: mmHg or kPa	2	Mean blood pressure (or cuff pressure)
3	PR value	4	Diastolic blood pressure
5	Systolic blood pressure		

Chapter 11 Temperature Monitoring

 **Note**

- **NC3 comes with temperature monitoring function as standard, NC3A is optional with a temperature monitoring function, NC3B does not have a temperature monitoring function.**

11.1 Temperature Monitoring

Temperature measurement is obtained by infrared ear thermometer. See the contents of “infrared ear thermometer instructions” for more details.

11.2 Infrared Ear Thermometer

11.2.1 Front View

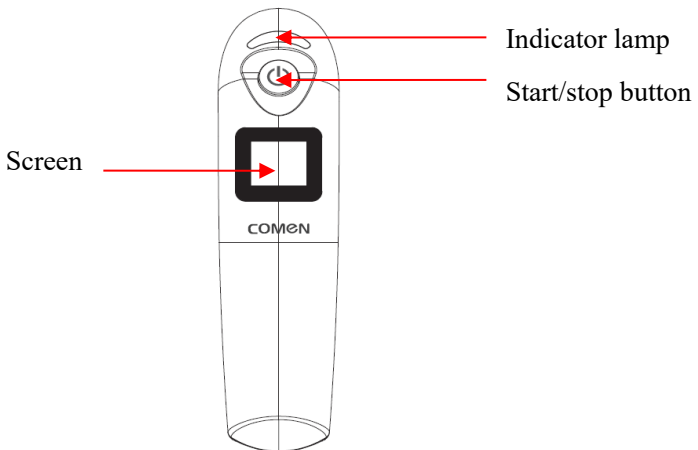

Figure 11-1 Front view

11.2.2 Side View

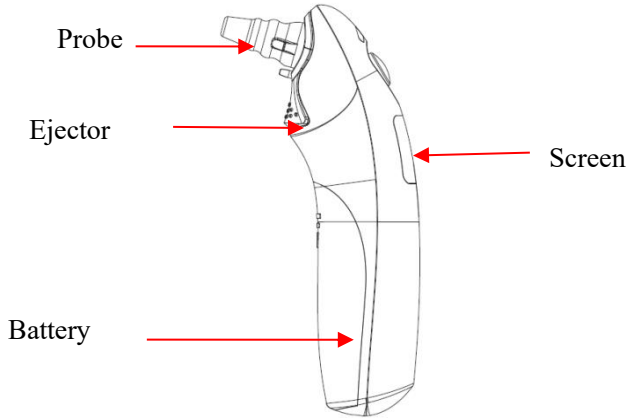

Figure 11-2 Side view

11.2.3 Temperature Measurement

- (a) Ensure the battery is in the ear thermometer.
- (b) Install a new lens filter on the probe, push it on until a click is heard.
- (c) Put the ear thermometer in the correct position, and press the measurement key, wait for several seconds, the probe then emits a beep.
- (d) Take out the thermometer, the temperature is shown on the screen.
- (e) Press the ejector key of the lens filter, remove it and put the thermometer back in its holder on the monitor.

11.2.4 Wireless Transmission Function

When the temperature probe is paired with the monitor, the temperature value can be displayed on the monitor by wireless transmission (figure11-3)





Figure 11-3 temperature display

(1) Wireless connection: when the temperature probe is off, press and hold the “ejector key”, simultaneously press “on/off key” and start the device. When the screen shows “SE” (alternate display of °C and °F is shown), then release the “ejector key”, and turn on the monitor within 10 seconds.

(2) Wireless connection/transmission status:

When wireless connection is successful, the monitor screen shows the icon””

When wireless connection is unsuccessful, there is no icon”” on screen;

When transmission is successful, the icon”” doesn’t flash;

(3) Trouble shooting tips:

Phenomenon	Possible Cause	Corrective action
Er0	Wireless module doesn't work	Contact service personnel
Wireless transmission failure	Ear thermometer is too far away from the receiving device	Keep the ear thermometer less than 10 meters away from the monitor without intervening obstructions
	Ear thermometer is not paired to a monitor successfully, or the monitor is off or in	Pair the temperature probe to the monitor again and ensure the monitor is switched on.

	Standby Mode.	
	Wireless transmission function is still not working	Contact service personnel



Warning

- **The ear thermometer must be verified and calibrated at least once every two years (or depending on hospital procedures), contact your service personnel when a calibration is necessary.**
- **Use the specified probe and lens filter, if not, it might cause damage or the measured value may not be accurate.**
- **The lens filter is disposable. Repeated use might cause cross infection.**
- **Before use, check whether the lens filter is intact, if not, please doesn't use it.**
- **Handle the ear thermometer with care, the probe should be put back into the holder when not in use.**
- **Discard the disposable lens filter in accordance with the requirements of local regulations or hospital discipline.**



Attention

- **Disposable temperature probes can only be used once.**
- **During the monitoring process, the temperature measuring instrument will automatically check itself once per hour. Self-checking will last 2 seconds, and will not affect the normal working of the temperature probe.**

11.3 Temperature Display

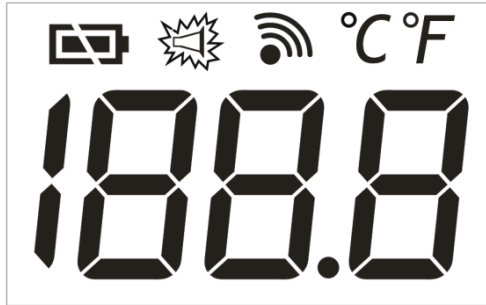

Figure 11-4 Temperature Probe Display

Appendix I Accessories

The manufacturer recommends the following accessories for this monitor.



Warning

- **Please use accessories designated by the manufacturer. Using other accessories may cause damage to this monitor.**
- **Disposable accessories only can be used once; reusing may result in performance deterioration or cross infection.**
- **Check the accessories and their packages for any signs of damage. Do not use them if any damage is detected.**
- **Disposable accessories shall be handled in accordance with the relevant hospital rules after use.**
- **When connecting and using the accessories avoid contact with each other or with any other metal devices.**

PN	Model	Type	Description
Comen SpO ₂ sensor			
040-000869-00	A0816-SA105PV	Reusable	Adult for Finger
040-000769-00	SLZ122	Reusable	Cable extender
040-000726-00	SAS104	Reusable	Adult for Finger
040-000730-00	SES104	Reusable	Neonatal for foot
040-000312-00	SAL104	Reusable	Adult for Finger
Nellcor SpO ₂ sensor			
009-000466-00	DOC-10	Reusable	Cable extender
040-000010-00	DS-100A	Reusable	Adult for Finger
040-000075-00	D-YS	Reusable	Neonatal for foot
Masimo SpO ₂ sensor			
040-000204-00	M-LNCS-10	Reusable	Cable extender
040-000203-00	M-LNCS DCI	Reusable	Adult for Finger
040-000361-00	M-LNCS YI	Reusable	Neonatal for foot
NIBP tubing			

Accessory

040-000808-00	/	Reusable	2m
040-000626-00	/	Reusable	3m
NIBP cuff			
040-000592-00	U1880S	Reusable	Adult, 25-35cm
040-000593-00	U1881S	Reusable	Pediatric, 18-26cm
040-000594-00	U1882S	Reusable	pediatric, 10-19cm
040-000595-00	U1883S	Reusable	Neonatal, 6-11cm
040-000596-00	U1884S	Reusable	Adult, 46 - 66 cm
040-000597-00	U1885S	Reusable	Small adult, 20 - 28 cm
040-000598-00	U1869S	Reusable	Large adult, 33 -47 cm
040-000599-00	U1889S	Reusable	Large adult, 33- 47 cm
040-001133-00	98-0084-95	Reusable	Pediatric, 12-19cm
040-001134-00	98-0084-96	Reusable	Small adult, 17-25 cm
040-001135-00	98-0084-97	Reusable	Adult, 23-33cm
040-001136-00	98-0084-98	Reusable	Large adult, 31-40cm
040-001137-00	98-0600-E1	Reusable	Pediatric, 12-19cm
040-001138-00	98-0600-E3	Reusable	Small adult, 17-25cm
040-001139-00	98-0600-E5	Reusable	Adult, 23-33cm
040-001140-00	98-0600-E7	Reusable	Large adult, 31-40cm
040-000142-00	CM1203	Reusable	Adult, 25-35 cm
040-000140-00	CM1202	Reusable	Pediatric, 18-26 cm
040-000120-00	CM1201	Reusable	pediatric, 10-19 cm
040-000141-00	CM1200	Reusable	Neonatal, 6-11 cm
040-000091-00	CM1205	Reusable	Adult thigh, 46-66 cm
040-000092-00	CM1204	Reusable	Adult thigh, 33-47 cm
Ear thermometer			
115-004974-00	IRT10	Reusable	Infrared in-ear thermometer
043-001696-00	/	Disposable	Transparent ear cap

Appendix II Reusable Accessory Service Life

Name	Service Life
Comen SpO ₂ sensor	Two years
Masimo and Nellcor SpO ₂ sensor	One year
Reusable NIBP cuff	18 months

Appendix III Product Specification

I. Monitor Type

(1) Product Classification

Name	type
Classification by protection against electric shock	Class I with internal power
Degree of protection against electric shock	BF defibrillation-proof applied parts: NIBP, SpO ₂ BF non defibrillation-proof applied part: TEMP
Classification by medical device directive	Cass IIa
Safety standard	MDD 93/42/EEC, EN ISO13485, EN ISO14971, EN 60601-1,EN 60601-1-2, EN60601-1-6, EN 1041, EN ISO10993-1,EN ISO10993-5, EN ISO 10993-10,EN 1060-1, EN1060-3, EN ISO 80601-2-30,EN ISO 80601-2-61, EN 62366, EN62304:2006
The degree of ingress protection (Monitor)	IPX1
The degree of ingress protection (infrared ear thermometer)	IPX0
The degree of safety in the presence of flammable anesthetic gas mixed such as air, oxygen or nitrous oxide mixture (It's NA)	The equipment is not suitable for use in the presence of a flammable anesthetic mixture with air or with oxygen or nitrous oxide.
Disinfection methods	Please refer to Chapter 6 for detailed information.

Product Specification

Operation Mode	Continuous operation
----------------	----------------------

(2) Environmental Specifications

Name	Specifications	
Work environment	Range of temperature	0°C~+40°C (without ear thermometer) 15°C~+36°C (with ear thermometer)
	Range of Relative Humidity	≤93% non-condensing (without ear thermometer) ≅85% non-condensing (with ear thermometer)
	Range of atmospheric pressure	70kPa~106kPa
Input Power Supply	Power voltage	100-240V~
	Power frequency	50/60Hz
	Rated input power	35VA
Transportation	Prevent severe shock, vibration and exposure to rain or snow during transportation	
Storage environment	Ambient temperature	-20°C~+60°C (without ear thermometer) -20°C~+55°C (with ear thermometer)
	Relative humidity	≤93% (without ear thermometer) ≤85% (with ear thermometer)
	Atmospheric pressure	70kPa~106kPa

(3) Battery

Name	Specifications
Battery specification (Monitor)	2200mAh 11.1V lithium ion battery
Duration of charging	When monitor is not switched on, the fully charged time will be a maximum of 3 hours. When monitor is switched on, the fully charged

Product Specification

	time will be a maximum of 5.5 hours.
Endurance time	The monitor can last at least 12 hours in Standby Mode with a fully charged battery. Moreover the monitor can continue working for five minutes after the first warning of low battery power.
Battery Specifications (ear thermometer)	D.C 3v (2 batteries)

II. Hardware Specification

(1) Display

Name	Specifications
Segment display screen	100mm*120mm

(2) Monitor LED

Name	Specifications
Start/stop indicator	1 (Yellow/Green)
AC power indicator	1 (Green)
Battery indicator	1 (Green)

(3) Interface

Name	Number
Power	1
RS-232	1
Equipotential socket	1

(4) Signal Output

Name	Number
Acoustic Output	
Louder speaker	Used for self-test sound and pulse sound

III. Monitor Specification

(1) Size and Weight

Name	Specifications
Size and Weight	Size:130mm (length)*125mm (width)*219mm (height)
	Weight of the device:1.25Kg, weight of battery:0.25Kg

(2) NIBP Specifications

Product Specification

Name	Specifications			
Way of measurement	Self-oscillation method			
Parameter display	Systolic pressure, diastolic blood, mean pressure and pulse			
Comen NIBP				
Range and accuracy of measurement	Range of measurement for adult	Systolic pressure	5.3-36kPa (40-270mmHg)	
		Diastolic pressure	1.3-28.7kPa (10-215mmHg)	
		Mean pressure	2.7-31.3kPa (20-235mmHg)	
	Range of measurement for pediatric	Systolic pressure	5.3-26.7kPa (40-200mmHg)	
		Diastolic pressure	1.3-20kPa (10-150mmHg)	
		Mean pressure	2.7-22kPa (20-165mmHg)	
	Range of measurement for neonate	Systolic pressure	5.3-18kPa (40-135mmHg)	
		Diastolic pressure	1.3-13.3kPa (10-100mmHg)	
		Mean pressure	2.7-14.7kPa (20-110mmHg)	
	Accuracy of Measurement	±5mmHg, when the non-invasive blood pressure is beyond the range, the monitor still displays properly, but does not consider accuracy.		
	Resolution	1mmHg(0.1kPa)		
	The measurement range and accuracy of static pressure	0 mmHg (0 kPa) ~300 mmHg (40.0 kPa) , ±3 mmHg (±0.4 kPa)		
Overpressure	Adult	297mmHg		

Product Specification

protection range and tolerance	Pediatric	240mmHg	
	Neonate	147mmHg	
	Tolerance	±3mmHg	
Suntech NIBP			
Range and accuracy of measurement	Range of measurement for adult	Systolic pressure	40mmHg - 260mmHg
		Diastolic pressure	20mmHg - 200mmHg
		Mean pressure	26 mmHg - 220mmHg
	Range of measurement for pediatric	Systolic pressure	40 mmHg - 160mmHg
		Diastolic pressure	20mmHg - 120mmHg
		Mean pressure	26 mmHg - 133mmHg
	Range of measurement for neonate	Systolic pressure	40 mmHg - 130mmHg
		Diastolic pressure	20mmHg - 100mmHg
		Mean pressure	26mmHg - 110mmHg
Static pressure measurement range and accuracy	Range	0kPa ~ 40.0kPa (0 mmHg ~ 300 mmHg)	
	Accuracy	±0.4kPa (±3 mmHg)	
Overpressure protection range and tolerance	Adult	297mmHg	
	Pediatric	240mmHg	
	Neonate	147mmHg	
	Tolerance	±3mmHg	

(3) SpO₂ Specifications

Name	Specifications
Data	2 seconds

Product Specification

averaging and other signal processing time				
Data update period	8 seconds			
Resolution of display	1%			
Accuracy Detection		Measurement range	Accuracy(70%~100%)	Accuracy(0%~69%)
	Comen	0%~100%	2%(measured without motion in adult/pediatric mode) 3%(measured without motion in neonate mode)	Not specified
	Masimo	1%~100%	2%(measured without motion in adult/pediatric mode) ±3 % (measured with motion in adult/child mode or measured in neonate mode))	
	Nellcor	0%~100%	2%(measured without motion in adult/pediatric mode) 3%(measured without motion in neonate mode)	
Perfusion Index(PI)	There is an indicator function in Masimo mode, the measurement range is 0.1%~20%, and the resolution is 0.1%.			

(4) Pulse Rate Specifications

Name	Specifications			
Range and accuracy		Measurement range	Resolution	Error
	Comen	20bpm~250bpm	1bpm	±2bpm
	Masimo	25bpm~240bpm	1bpm	±3bpm (no motion) ±5bpm (motion)
	Nellcor	25bpm~300bpm	1bpm	±3bpm within 20bpm~250bpm range. The measurement accuracy within 251bpm~300bpm range is not defined.

(5) TEMP Specifications

Name	Specifications	
Range and accuracy	Range	34°C~42.2°C (93.2°F~107.6°F)
	Error	35°C~42°C: the error is ±0.2°C (±0.4°F) Other range: ±0.3°C (±0.5°F)
Resolution	0.1°C (0.1°F)	

Appendix IV Fault Code Information

When failures happen, fault codes will be shown in the corresponding area, and the related parameters will flash on the screen.

In Measurement Mode, press “” to clear a one-time fault code. But other codes will be continuous displayed on the screen.

1. Error Code Table

Error Code	Error Description	Cause	One-Time Error Code (YES, NO)	Solution
01	SpO ₂ module communication has stopped	There is a problem with the SpO ₂ module or communication	NO	Stop measuring SpO ₂ function, and contact with service personnel of Comen or biomedical engineer.
02	Unrecognized probe	The probe can't be recognized by the SpO ₂ module	NO	Check the connection between probe and monitor, if the fault still can't be cancelled, contact with service personnel of Comen or biomedical engineer.

Fault Code Information

Error Code	Error Description	Cause	One-Time Error Code (YES, NO)	Solution
03	Weak signal (Low SIQ)	The signal is too weak	NO	Check patient's vital signs, and change the measurement site.
04	Too much light	SpO ₂ probe is too loose	NO	Check and connect the SpO ₂ probe again, ensure the probe is stable
05	SpO ₂ board error	There is a problem with the SpO ₂ module	NO	Do not use it and contact with service personnel of Comen or biomedical engineer.
06	PI too low	The PI is too low; the SpO ₂ signal is too weak.	NO	Adjust the probe on the patient and move the probe to a better location.
07	Probe error	There is a problem with the SpO ₂ probe	NO	Do not use the probe and contact with service personnel of Comen or biomedical engineer.
08	Interference	The signal has	NO	Avoid excessive

Fault Code Information

Error Code	Error Description	Cause	One-Time Error Code (YES, NO)	Solution
		been interfered with by motion or nearby electrosurgical equipment		patient movement and avoid using electrosurgical equipment near the patient.
51	Unable to get an SpO ₂ value	There is a problem with the SpO ₂ probe or the SpO ₂ probe module.	NO	Stop using the probe or the measuring function of SpO ₂ module, and contact with service personnel of Comen or biomedical engineer.
52	Unable to get a pulse value	There is a problem with the SpO ₂ probe or the SpO ₂ probe module.	NO	Stop using the probe or the measuring function of SpO ₂ module, and contact with service personnel of Comen or biomedical engineer.
10	Loose cuff	The NIBP cuff is not properly connected	YES	Check and connect the cuff again.

Fault Code Information

Error Code	Error Description	Cause	One-Time Error Code (YES, NO)	Solution
11	Air leak	The NIBP cuff is not properly connected or there is a leak in the air tube	YES	Check the connection or use a new cuff, if the problem persists, contact with the service personnel.
12	Air pressure Error	The pressure is not stable, such as hose entanglement	YES	Check the connection or use a new cuff, if the problem persists, contact with the service personnel.
13	NIBP weak signal	The cuff is loose or the signal is weak	YES	Check the patient type setting and the connection or replace a cuff. If the error persists, contact the service personnel
14	NIBP overrange	The measured value is not within the specified range	YES	Contact the service personnel
15	NIBP excessive motion	Arm motion	YES	Check the patient's

Fault Code Information

Error Code	Error Description	Cause	One-Time Error Code (YES, NO)	Solution
				condition and reduce the motion
16	NIBP overpressure detection	the airway may be occluded	YES	Check the airway and the patient's condition, if the error persists, contact the service personnel
17	NIBP air leak	There is a leak in the air tube	NO	Check and replace the parts that cause the leak. If the error persists, contact with the service personnel
18	NIBP system error	There is a problem with the system of pressure pump	NO	Do not use the NIBP module and contact with the service personnel
19	NIBP timeout	The measurement time exceeds 120s in adult/ pediatric mode	YES	Check the patient type setting and connection. If needed, replace a cuff, if the error persists,

Fault Code Information

Error Code	Error Description	Cause	One-Time Error Code (YES, NO)	Solution
				contact with the service personnel
20	NIBP signal saturated	Excess motion	YES	Reduce the motion and measure again
21	NIBP self-test error	There is a problem with the sensor or other hardware	NO	Do not use the NIBP module and contact with the service personnel
22	NIBP communication error	There is a problem with the NIBP module or host	NO	Restart the monitor, if the error persists, contact with the service personnel
23	NIBP cuff type wrong	The cuff doesn't match the patient type	NO	Replace a cuff and measure
24	Inflation tube blocked (SunTech)	Inflation tube blocked	YES	1. Check the hose for sharp bends or being pinched. 2. Check if the patient is lying on the cuff. 3. Check if the cuff is in the correct position.
25	Measurement termination	Measurement termination	YES	The current NIBP

Fault Code Information

Error Code	Error Description	Cause	One-Time Error Code (YES, NO)	Solution
	(SunTech)			measurement is terminated.
26	NIBP needs calibration (SunTech)	NIBP needs calibration	YES	Contact the service personnel
27	Systolic blood pressure measurement overrange.	Systolic blood pressure measurement overrange.	YES	Contact a doctor to check the patient
28	Mean blood pressure measurement overrange.	Mean blood pressure measurement overrange	YES	Contact a doctor to check the patient
29	Diastolic blood pressure measurement overrange.	Diastolic blood pressure measurement overrange.	YES	Contact a doctor to check the patient
53	Module is busy (SunTech)	Module not responding	NO	Wait for a while, then repeat the previous operation.
30	Ear thermometer communication error	The battery is too low or there is a problem with the communication module	NO	Replace a battery, and restart the monitor, if the error persists, contact with the service personnel
46	Battery too low	The power is too low	NO	Connect the monitor to an

Fault Code Information

Error Code	Error Description	Cause	One-Time Error Code (YES, NO)	Solution
				AC power source and allow the batteries to charge. If the battery is charged for 6 hours, and the error still exists, contact the service personnel
47	12V too high	12V sampling value is 15% higher than the normal range	NO	Restart the monitor, if the error persists, contact with the service personnel
48	12V too low	12V sampling value is 15% lower than the normal range		
49	5V too high	12V sampling value is 15% higher than the normal range		
50	5V too low	12V sampling value is 15% lower than the normal range		

Appendix V EMC



Attention

- **The monitor meets the EMC requirements of IEC60601-1-2**
- **The user needs to install and use according to electromagnetism compatibility information supplied with the monitor**
- **Portable and mobile RF communication devices may affect the monitor. And in case of interference, keep the monitor away from phones and ovens, etc.**
- **Guidance and manufacturer's declaration are shown in the appendix**



Warning

- **Use of this equipment adjacent to or stacked with other equipment should be avoided because it could result in improper operation. If such use is necessary, this equipment and the other equipment should be observed to verify that they are operating normally.**
- **Use of accessories, transducers and cables other than those specified or provided by the manufacturer of this the NC3/NC3A/NC3B Vital Signs Monitor could result in increased electromagnetic emissions or decreased electromagnetic immunity of this equipment and result in improper operation**
- **Portable RF communications equipment (including peripherals such as antenna cables and external antennas) should be used no closer than 30 cm (12 inches) to any part of the NC3/NC3A/NC3B Vital Signs Monitor, including cables specified by the manufacturer. Otherwise, degradation of the performance of this equipment could result.**

declaration - electromagnetic emission

The NC3/NC3A/NC3B Vital Signs Monitor is intended for use in the electromagnetic environment specified below. The customer or the user of the NC3/NC3A/NC3B Vital Signs Monitor should assure that it is used in such an environment.

Emissions test	Compliance	Electromagnetic environment - guidance
RF emissions CISPR 11	Group 1	The NC3/NC3A/NC3B Vital Signs Monitor uses RF energy only for its internal function. Therefore, its RF emissions are very low and are not likely to cause any interference in nearby electronic equipment.
RF emissions CISPR 11	Class A	The NC3/NC3A/NC3B Vital Signs Monitor is suitable for use in all establishments other than domestic and those directly connected to the public low-voltage power supply network that supplies buildings used for domestic purposes.
Harmonic emissions IEC 61000-3-2	Class A	
Voltage fluctuations / flicker emissions IEC 61000-3-3	Complies	

declaration - electromagnetic immunity

The NC3/NC3A/NC3B Vital Signs Monitor is intended for use in the electromagnetic environment specified below. The customer or the user of the NC3/NC3A/NC3B Vital Signs Monitor should assure that it is used in such an environment.

Immunity test	IEC 60601 test level	Compliance level	Electromagnetic environment – guidance
Electrostatic discharge (ESD) IEC 61000-4-2	± 8 kV contact ± 2 kV, ± 4 kV, ± 8 kV, ± 15 kV air	± 8 kV contact ± 2 kV, ± 4 kV, ± 8 kV, ± 15 kV air	Floors should be wood, concrete or ceramic tile. If floors are covered with synthetic material, the relative humidity should be at least 30 %.
Electrical fast transient/burst IEC 61000-4-4	± 2 kV for power supply lines ± 1 kV for input/output lines 100 kHz repetition frequency	± 2 kV for power supply lines ± 1 kV for input/output lines 100 kHz repetition frequency	Mains power quality should be that of a typical commercial or hospital environment.

EMC

Surge IEC 61000-4-5	$\pm 0.5\text{kV}, \pm 1\text{kV}$ line(s) to lines $\pm 0.5\text{kV}, \pm 1\text{kV},$ $\pm 2\text{kV}$ line(s) to earth	$\pm 0.5\text{kV}, \pm 1\text{kV}$ line(s) to lines $\pm 0.5\text{kV}, \pm 1\text{kV},$ $\pm 2\text{kV}$ line(s) to earth	Mains power quality should be that of a typical commercial or hospital environment.
Voltage dips, interruptions and variations IEC 61000-4-11	0 % U_T for 0.5 cycle: at 0°, 45°, 90°, 135°, 180°, 225°, 270° and 315° 0 % U_T for 1 cycle and 70 % U_T for 25/30cycles: at 0° 0 % U_T for 250/300 cycle	0 % U_T for 0.5 cycle: at 0°, 45°, 90°, 135°, 180°, 225°, 270° and 315° 0 % U_T for 1 cycle and 70 % U_T for 25/30cycles: at 0° 0 % U_T for 250/300 cycle	Mains power quality should be that of a typical commercial or hospital environment. If the user of the NC3/NC3A/NC3B Vital Signs Monitor requires continued operation during power mains interruptions, it is recommended that the NC3/NC3A/NC3B Vital Signs Monitor be powered from an uninterruptible power supply or a battery.
Power frequency magnetic field IEC 61000-4-8	30 A/m,50/60 Hz	30 A/m	Power frequency magnetic fields should be at levels characteristic of a typical location in a typical commercial or hospital environment.
NOTE U_T is the a.c. mains voltage prior to application of the test level.			

declaration - electromagnetic immunity

The NC3/NC3A/NC3B Vital Signs Monitor is intended for use in the electromagnetic environment specified below.

The customer or the user of the NC3/NC3A/NC3B Vital Signs Monitor should assure that it is used in such an environment.

Immunity test	IEC 60601 test level	Compliance level	Electromagnetic environment – guidance
Conducted RF IEC 61000-4-6	3 V 0.15 MHz to 80 MHz 6 V in ISM and between 0.15 MHz and 80 MHz	3 V 0.15 MHz to 80 MHz 6 V in ISM and between 0.15 MHz and 80 MHz	Portable and mobile RF communications equipment should be used no closer to any part of the NC3/NC3A/NC3B Vital Signs Monitor, including cables, than the recommended separation distance calculated from the equation applicable to the frequency of the transmitter. Recommended separation distance
Radiated RF IEC61000-4-3	3 V/m 80 MHz to 2.7 GHz	3 V/m	$d = \left[\frac{3.5}{V_1} \right] \sqrt{P} \quad 150 \text{ KHz}$ to 80 MHz $d = \left[\frac{3.5}{E_1} \right] \sqrt{P} \quad 80 \text{ MHz to}$ 800 MHz $d = \left[\frac{7}{E_1} \right] \sqrt{P} \quad 800 \text{ MHz}$ to 2.7 GHz where P is the maximum output power rating of the transmitter in watts (W) according to the transmitter manufacturer and d is the recommended separation distance in meters (m). Field strengths from fixed

			<p>RF transmitters, as determined by an electromagnetic site survey, ^ashould be less than the compliance level in each frequency range. ^b</p> <p>Interference may occur in the vicinity of equipment marked with the following symbol:</p> 
<p>NOTE 1 At 80MHz and 800MHz, the higher frequency range applies.</p> <p>NOTE 2 These guidelines may not apply in all situations. Electromagnetic propagation is affected by absorption and reflection from structures, objects and people.</p>			
<p>^a Field strengths from fixed transmitters, such as base stations for radio (cellular/cordless) telephones and land mobile radios, amateur radio, AM and FM radio broadcast and TV broadcast cannot be predicted theoretically with accuracy. To assess the electromagnetic environment due to fixed RF transmitters, an electromagnetic site survey should be considered. If the measured field strength in the location in which the NC3/NC3A/NC3B Vital Signs Monitor is used exceeds the applicable RF compliance level above, the NC3/NC3A/NC3B Vital Signs Monitor should be observed to verify normal operation. If abnormal performance is observed, additional measures may be necessary, such as reorienting or relocating the NC3/NC3A/NC3B Vital Signs Monitor.</p> <p>^b Over the frequency range 150 kHz to 80 MHz, field strengths should be less than 3V/m.</p>			

Recommended separation distances between portable and mobile RF communications equipment and the NC3/NC3A/NC3B

The NC3/NC3A/NC3B Vital Signs Monitor is intended for use in an electromagnetic environment in which radiated RF disturbances are controlled. The customer or the user of the NC3/NC3A/NC3B Vital Signs Monitor can help prevent electromagnetic interference by maintaining a minimum distance between portable and mobile RF communications equipment (transmitters) and the NC3/NC3A/NC3B Vital Signs Monitor as recommended below, according to the maximum output power of the communications equipment

Rated maximum output of transmitter W	Separation distance according to frequency of transmitter m		
	150 kHz to 80 MHz $d = 1.2\sqrt{P}$	80 MHz to 800 MHz $d = 1.2\sqrt{P}$	800 MHz to 2.7 GHz $d = 2.3\sqrt{P}$
0.01	0.12	0.12	0.23
0.1	0.38	0.38	0.73
1	1.2	1.2	2.3
10	3.8	3.8	7.3
100	12	12	23

For transmitters rated at a maximum output power not listed above the recommended separation distance d in meters (m) can be estimated using the equation applicable to the frequency of the transmitter, where P is the maximum output power rating of the transmitter in watts (W) according to the transmitter manufacturer.

NOTE 1 At 80 MHz and 800 MHz, the separation distance for the higher frequency range applies.

NOTE 2 These guidelines may not apply in all situations. Electromagnetic propagation is affected by absorption and reflection from structures, objects and people.

declaration - IMMUNITY to proximity fields from RF wireless communications equipment

The NC3/NC3A/NC3B Vital Signs Monitor is intended for use in an electromagnetic environment in which RF wireless communications equipment are controlled.

Immunity test	IEC60601 test level				Compliance level	Electromagnetic environment - guidance
	Test frequency	Modulation	Maximum power	Immunity level		
Radiated RF IEC 61000-4-3	385 MHz	**Pulse Modulation: 18Hz	1.8W	27 V/m	27 V/m	
	450 MHz	*FM+ 5Hz deviation: 1kHz sine	2 W	28 V/m	28 V/m	
	710 MHz 745 MHz 780 MHz	**Pulse Modulation: 217Hz	0.2 W	9 V/m	9 V/m	
	810 MHz 870 MHz 930 MHz	**Pulse Modulation: 18Hz	2 W	28 V/m	28 V/m	
	1720 MHz 1845 MHz 1970 MHz	**Pulse Modulation: 217Hz	2 W	28 V/m	28 V/m	
	2450 MHz	**Pulse Modulation: 217Hz	2 W	28 V/m	28 V/m	
	5240 MHz 5500 MHz 5785 MHz	**Pulse Modulation: 217Hz	0.2 W	9 V/m	9 V/m	

Note * - As an alternative to FM modulation, 50 % pulse modulation at 18 Hz may be used because while it does not represent actual modulation, it would be worst case.

Note** - The carrier shall be modulated using a 50 % duty cycle square wave signal.