

FCC/ISED - TEST REPORT

Report Number : **68.950.21.0688.01** Date of Issue: **2021-10-09**

Model : **SOUNDBOKS GO**

Product Type : Wireless Bluetooth Speaker

Applicant : Sun Technique Electric Co., Ltd.

Address : #35, Songshui Rd, Songmushan Village, Dalang Town, Dongguan, Guangdong, China.

Manufacturer : Sun Technique Electric Co., Ltd.

Address : #35, Songshui Rd, Songmushan Village, Dalang Town, Dongguan, Guangdong, China.

Test Result : **Positive** **Negative**

Total pages including Appendices : **47**

Any use for advertising purposes must be granted in writing. This technical report may only be quoted in full. This report is the result of a single examination of the object in question and is not generally applicable evaluation of the quality of other products in regular production. For further details, please see testing and certification regulation, chapter A-3.4.



1 Table of Contents

1	Table of Contents.....	2
2	Details about the Test Laboratory.....	3
3	Description of the Equipment Under Test.....	4
4	Summary of Test Standards.....	5
5	Summary of Test Results.....	6
6	General Remarks.....	7
7	Test Setups.....	8
8	Systems test configuration.....	9
9	Technical Requirement.....	10
9.1	Conducted Emission.....	10
9.2	Conducted output power.....	13
9.3	20 dB bandwidth and 99% Occupied Bandwidth.....	16
9.4	Carrier Frequency Separation.....	20
9.5	Number of hopping frequencies.....	22
9.6	Dwell Time.....	24
9.7	Spurious RF conducted emissions.....	26
9.8	Band edge testing.....	31
9.9	Spurious radiated emissions for transmitter.....	36
10	Test Equipment List.....	46
11	System Measurement Uncertainty.....	47



2 Details about the Test Laboratory

Details about the Test Laboratory

Test Site 1

Company name: TÜV SÜD Certification and Testing (China) Co., Ltd. Shenzhen Branch
Building 12&13, Zhiheng Wisdomland Business Park,
Guankou Erlu, Nantou, Nanshan District,
Shenzhen City, 518052,
P. R. China

FCC Designation Number: CN5009

FCC Registration No.: 514049

IC Registration No.: 10320A

Telephone: 86 755 8828 6998
Fax: 86 755 8828 5299

3 Description of the Equipment Under Test

Product:	Wireless Bluetooth Speaker
Model no.:	SOUNDBOKS GO
FCC ID:	2A29M-SBGO-21-1
IC	27750-SBGO211
HVIN	SOUNDBOKS Go
PMN	Wireless Bluetooth Speaker
Options and accessories:	Adapter: KA4802A-1403300P
Rating:	14.0VDC, 3.3A
Adapter:	Input:100-240Vac, 50/60Hz; 1.2A Output: 14.0Vdc, 3.3A 46.2W
Battery	Li-ion Rechargeable Battery 7.8Ah/12.8V 99.84Wh LiFePO4 Input:14.5VDC, 3.0A Output: 12.8Vdc, 7.8A
RF Transmission Frequency:	2402MHz-2480MHz for Bluetooth 2400MHz-2480MHz for 2.4G,
Antenna Type:	Integrated antenna for 2.4G PCB antenna for BT
Antenna Gain:	1.927dBi for BT antenna, 2dBi for 2.4G Hopping antenna
Description of the EUT:	The Equipment Under Test (EUT) is a Wireless Bluetooth Speaker which supports Bluetooth function and 2.4G hopping.

4 Summary of Test Standards

Test Standards	
FCC Part 15 Subpart C 10-1-2020 Edition	PART 15 - RADIO FREQUENCY DEVICES Subpart C - Intentional Radiators
RSS-247 Issue 2 February 2017	Digital Transmission Systems (DTSS), Frequency Hopping Systems (FHSS) and License-Exempt Local Area Network (LE-LAN) Devices
RSS-Gen Issue 5, Amendment 2, February 2021	General Requirements and Information for the Certification of Radio Apparatus

All the test methods were according to KDB 558074 D01 15.247 Meas Guidance v05r02 and ANSI C63.10 (2013).

5 Summary of Test Results

Technical Requirements			
FCC Part 15 Subpart C & RSS-247 Issue 2			
Test Condition		Test Result	Test Site
15.207 RSS-GEN 8.8	Conducted emission AC power port	Pass	Site 1
15.247(b)(1) RSS-247 5.4(b)	Conducted output power	Pass	Site 1
RSS-247 5.4(b)	Equivalent Isotropic Radiated Power	N/A	--
15.247(e) RSS-247 5.2(b)	Power spectral density	N/A	--
15.247(a)(2) RSS-247 5.2(a)&RSS- GEN 6.7	6dB bandwidth and 99% Occupied Bandwidth	N/A	--
15.247(a)(2) RSS-247 5.1(b)	20dB bandwidth and 99% Occupied Bandwidth	Pass	Site 1
15.247(a)(1) RSS-247 5.1(b)	Min. of Hopping Channel Carrier Frequency Separation	Pass	Site 1
15.247(a)(1)(iii) RSS-247 5.1(d)	Min number of hopping frequencies	Pass	Site 1
15.247(a)(1)(iii) RSS-247 5.1(d)	Dwell Time - Average Time of Occupancy	Pass	Site 1
15.247(d) RSS-247 5.5	Spurious RF conducted emissions	Pass	Site 1
15.247(d) RSS-247 5.5	Band edge	Pass	Site 1
15.247(d) & 15.209 & 15.205, RSS-247 5.5 & RSS-Gen 6.13	Spurious radiated emissions for transmitter	Pass	Site 1
15.207 RSS-GEN 8.8	Conducted emission AC power port	See note 2	--

Note 1: N/A=Not Applicable.

Note 2: The EUT uses an Internal antenna, which gain is 1.927dBi for BT antenna, 2dBi for 2.4G Hopping antenna. In accordance to §15.203, it is considered sufficiently to comply with the provisions of this section.

6 General Remarks

Remarks

This submittal(s) (test report) is intended for FCC ID: 2A29M-SBGO-21-1, IC: 27750-SBGO211 complies with RSS-247, RSS-GEN, and 15.207, 15.209, 15.205, 15.247 of the FCC Part 15, Subpart C

This report is for the 2.4G Hopping part.

SUMMARY:

All tests according to the regulations cited on page 6 were

■ - Performed

□ - **Not** Performed

The Equipment Under Test

■ - **Fulfills** the general approval requirements.

□ - **Does not** fulfill the general approval requirements.

Sample Received Date: 2021-07-20

Testing Start Date: 2021-07-21

Testing End Date: 2021-09-10

- TÜV SÜD Certification and Testing (China) Co., Ltd. Shenzhen Branch -

Reviewed by:

Prepared by:

Tested by:

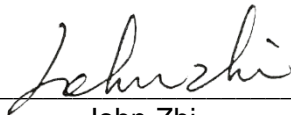

John Zhi
Project Manager



Warlen Song
Project Engineer

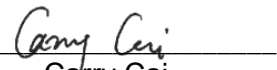

Garry Cai
Test Engineer

7 Test Setups

7.1 AC Power Line Conducted Emission test setups

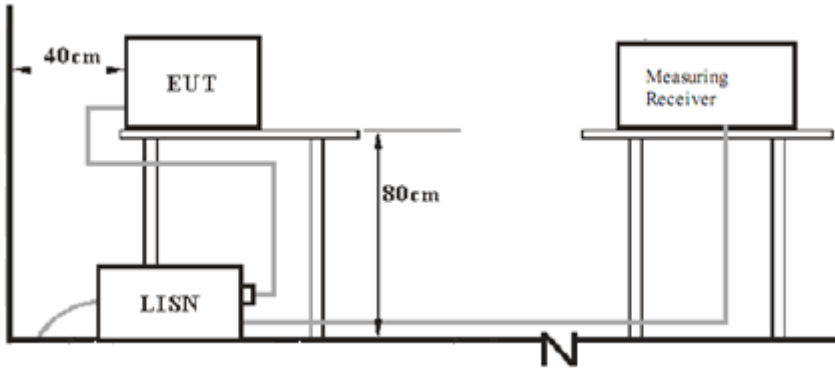

7.2 Radiated test setups Below 1GHz

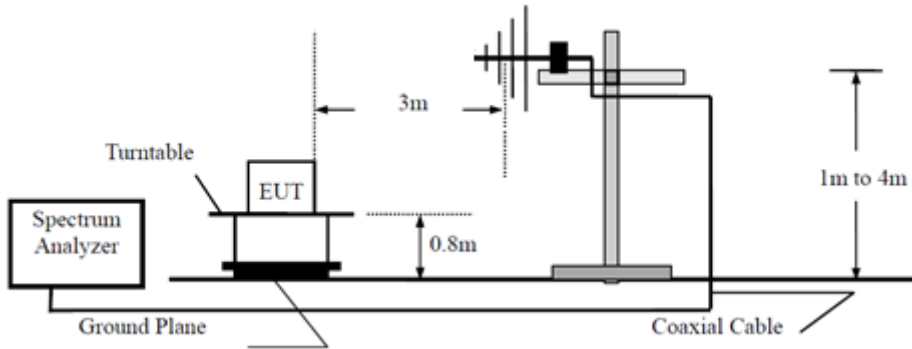

Above 1GHz

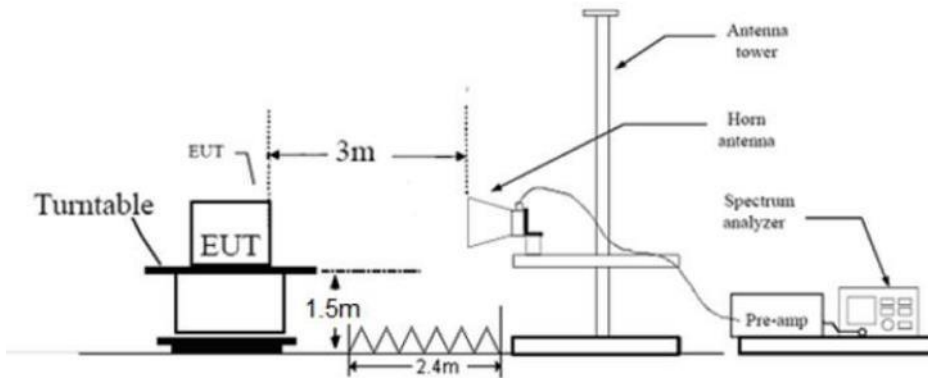

7.3 Conducted RF test setups

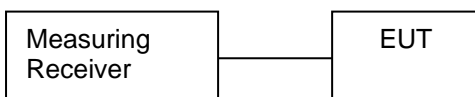

8 Systems test configuration

Auxiliary Equipment Used during Test:

Description	Manufacturer	Model no.	Serial no.	CAL. DUE DATE
Laptop	Thinkpad	X220	---	---

The system was configured to hopping mode and non-hopping mode.

Hopping mode: typical working mode (normal hopping status)

Non-hopping mode: The system was configured to operate at a signal channel transmitting.

Channel Table:

Channel #	Center Frequency (GHz)	Channel #	Center Frequency (GHz)
Center Frequencies (Channel Table)			
1	2.4035	26	2.4420
2	2.4051	27	2.4435
3	2.4066	28	2.4450
4	2.4081	29	2.4466
5	2.4097	30	2.4481
6	2.4112	31	2.4496
7	2.4128	32	2.4512
8	2.4143	33	2.4527
9	2.4158	34	2.4543
10	2.4174	35	2.4558
11	2.4189	36	2.4573
12	2.4204	37	2.4589
13	2.4220	38	2.4604
14	2.4235	39	2.4619
15	2.4251	40	2.4635
16	2.4266	41	2.4650
17	2.4281	42	2.4666
18	2.4297	43	2.4681
19	2.4312	44	2.4696
20	2.4327	45	2.4712
21	2.4343	46	2.4727
22	2.4358	47	2.4742
23	2.4374	48	2.4758
24	2.4389	49	2.4773
25	2.4404		

Remark: The EUT operation only 15 channels in these 49 channels.

9 Technical Requirement

9.1 Conducted Emission

Test Method

1. The EUT was placed 0.4 meter from the conducting wall of the shielding room was kept at least 80 centimeters from any other grounded conducting surface.
2. Connect EUT to the power mains through a line impedance stabilization network (LISN).
3. All the support units are connecting to the other LISN.
4. The LISN provides 50 ohm coupling impedance for the measuring instrument.
5. Both sides of AC line were checked for maximum conducted interference.
6. The frequency range from 150 kHz to 30 MHz was searched.
7. Set the test-receiver system to Peak Detect Function and specified bandwidth (IF Bandwidth = 9kHz) with Maximum Hold Mode. Then measurement is also conducted by Average Detector and Quasi-Peak Detector Function respectively.

Limit

Frequency MHz	QP Limit dB μ V	AV Limit dB μ V
0.150-0.500	66-56*	56-46*
0.500-5	56	46
5-30	60	50

*Decreases with the logarithm of the frequency.

Conducted Emission

Product Type : Wireless Bluetooth Speaker
 M/N : SOUNDBOKS GO
 Operating Condition : Normal Working(Aux in + Charing)
 Test Specification : Line
 Comment : AC 120V/60Hz

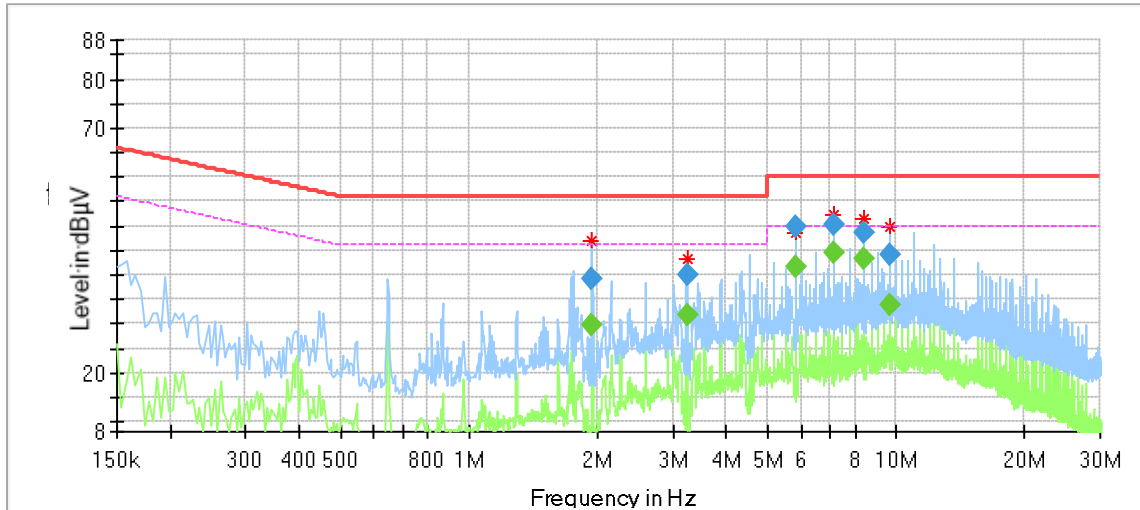

Critical_Freqs

Frequency (MHz)	MaxPeak (dBµV)	Average (dBµV)	Limit (dBµV)	Margin (dB)	Line	Corr. (dB)
1.937500	46.78	---	56.00	9.22	L1	9.22
3.233500	43.33	---	56.00	12.67	L1	9.26
5.821500	48.59	---	60.00	11.41	L1	9.33
7.113500	52.19	---	60.00	7.81	L1	9.36
8.409500	51.55	---	60.00	8.45	L1	9.38
9.701500	49.91	---	60.00	10.09	L1	9.39

Final_Result

Frequency (MHz)	QuasiPeak (dBµV)	Average (dBµV)	Limit (dBµV)	Margin (dB)	Line	Corr. (dB)
1.937500	---	29.66	46.00	16.34	L1	9.22
1.937500	39.35	---	56.00	16.65	L1	9.22
3.233500	---	31.62	46.00	14.38	L1	9.26
3.233500	40.09	---	56.00	15.91	L1	9.26
5.821500	---	41.81	50.00	8.19	L1	9.33
5.821500	49.72	---	60.00	10.28	L1	9.33
7.113500	---	44.36	50.00	5.64	L1	9.36
7.113500	50.35	---	60.00	9.65	L1	9.36
8.409500	48.61	---	60.00	11.39	L1	9.38
8.409500	---	43.21	50.00	6.79	L1	9.38
9.701500	43.94	---	60.00	16.06	L1	9.39
9.701500	---	33.70	50.00	16.30	L1	9.39

Remark :

Level=Reading Level + Correction Factor

Correction Factor=Cable Loss + LISN Factor

(The Reading Level is recorded by software which is not shown in the sheet)

Conducted Emission

Product Type : Wireless Bluetooth Speaker
 M/N : SOUNDBOKS GO
 Operating Condition : Normal Working(Aux in + Charing)
 Test Specification : Neutral
 Comment : AC 120V/60Hz

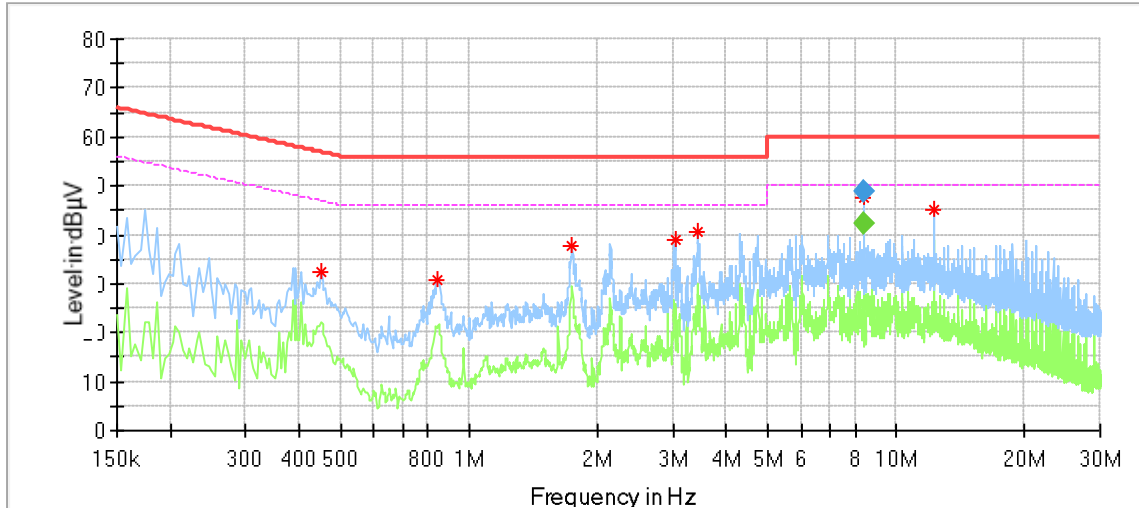

Critical_Freqs

Frequency (MHz)	MaxPeak (dBµV)	Average (dBµV)	Limit (dBµV)	Margin (dB)	Line	Corr. (dB)
0.450000	32.22	---	56.88	24.65	N	9.39
0.842000	30.75	---	56.00	25.25	N	9.39
1.742000	37.59	---	56.00	18.41	N	9.41
3.038000	38.83	---	56.00	17.17	N	9.44
3.430000	40.66	---	56.00	15.34	N	9.45
8.409500	47.70	---	60.00	12.30	N	9.59
12.286000	45.16	---	60.00	14.84	N	9.62

Final_Result

Frequency (MHz)	QuasiPeak (dBµV)	Average (dBµV)	Limit (dBµV)	Margin (dB)	Line	Corr. (dB)
8.409500	---	42.12	50.00	7.88	N	9.59
8.409500	48.83	---	60.00	11.17	N	9.59

Remark :

Level=Reading Level + Correction Factor

Correction Factor=Cable Loss + LISN Factor

(The Reading Level is recorded by software which is not shown in the sheet)

9.2 Conducted output power

Test Method

1. The EUT was placed on 0.8m height table, the RF output of EUT was connected to the power meter by RF cable. The path loss was compensated to the results for each measurement.
2. Use the following spectrum analyzer settings:
RBW > the 6dB bandwidth of the emission being measured, VBW \geq 3RBW, Span \geq 3RBW
Sweep = auto, Detector function = peak, Trace = max hold.
3. Allow the trace to stabilize. Use the marker-to-peak function to set the marker to the peak of the emission. The indicated level is the peak output power.

Limits

According to §15.247(b)(1), conducted output power limit as below:

Frequency Range MHz	Limit W	Limit dBm
2400-2483.5	≤ 1	≤ 30

According to RSS-247 5.4(b), conducted output power limit as below:

Frequency Range MHz	Limit W	Limit dBm
2400-2483.5	≤ 1	≤ 30

According to & RSS-247 5.4(b), EIRP limit as below:

Frequency Range MHz	Limit W	Limit dBm
2400-2483.5	≤ 4	≤ 36.02

Conducted output power

FSK modulation Test Result

Frequency MHz	Conducted Output Power dBm	EIRP dBm	Result
Low channel 2403.5MHz	7.4	9.4	Pass
Middle channel 2440MHz	6.9	8.9	Pass
High channel 2477.3MHz	6.58	8.58	Pass

Low channel 2403.5MHz

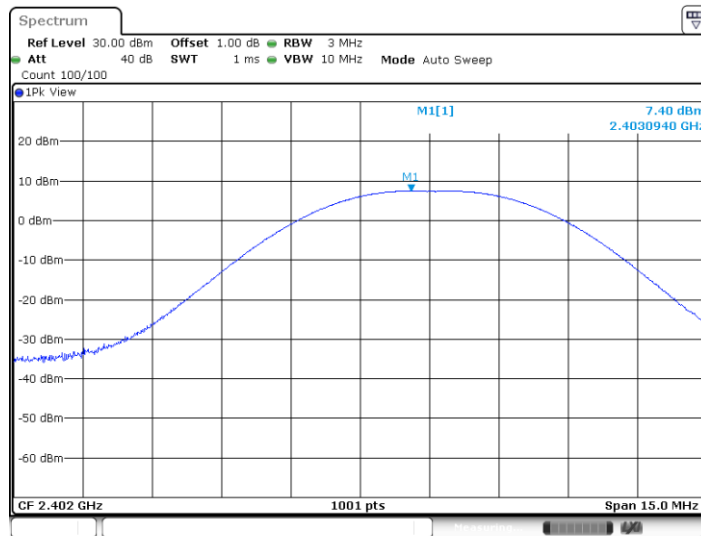

Date: 3.SEP.2021 17:31:06

Middle channel 2440.4MHz

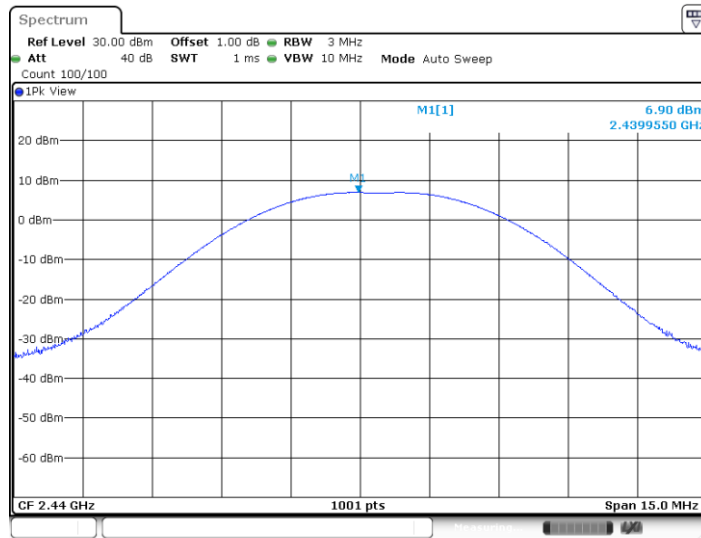

Date: 3.SEP.2021 17:34:48

High channel 2477.3MHz

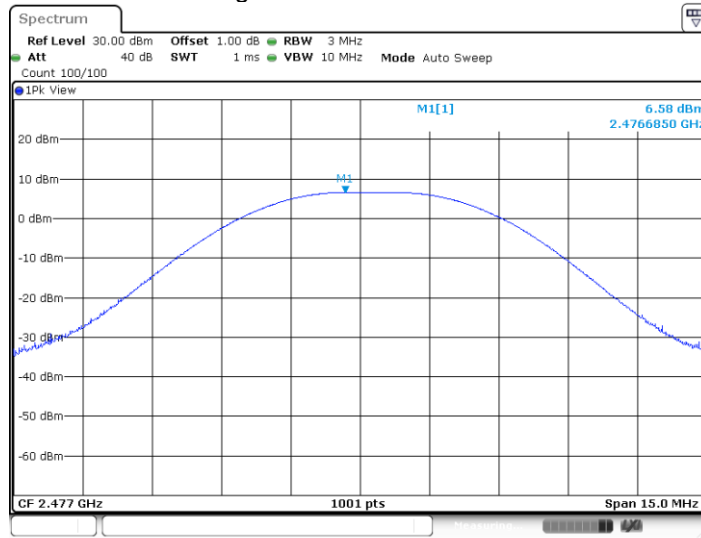

Date: 3.SEP.2021 17:35:05

9.3 20 dB bandwidth and 99% Occupied Bandwidth

Test Method

1. The RF output of EUT was connected to the test receiver by RF cable. The path loss was compensated to the results for each measurement.
2. Set to the maximum power setting and enable the EUT transmit continuously.
3. Use the following test receiver settings:
Span = approximately 5 times the 20dB bandwidth, centered on a hopping channel
RBW > the 20dB bandwidth of the emission being measured, VBW \geq RBW,
Sweep = auto, Detector function = peak, Trace = max hold
4. Allow the trace to stabilize. Use the marker-to-peak function to set the marker to the peak of the emission. Measure the frequency difference of two frequencies that were attenuated 20 dB from the reference level. Record the frequency difference as the emission bandwidth. Record the results.
5. Repeat above procedures until all frequencies measured were complete.

Limit

Limit [kHz]

N/A

20 dB bandwidth and 99% Occupied Bandwidth

FSK Modulation test result

Frequency MHz	20 dB Bandwidth MHz	99% Bandwidth MHz	Limit MHz	Result
2403.5	2.151	2.194	--	Pass
2440.4	2.358	2.188	--	Pass
2477.3	2.340	2.197	--	Pass

Low channel 2403.5MHz

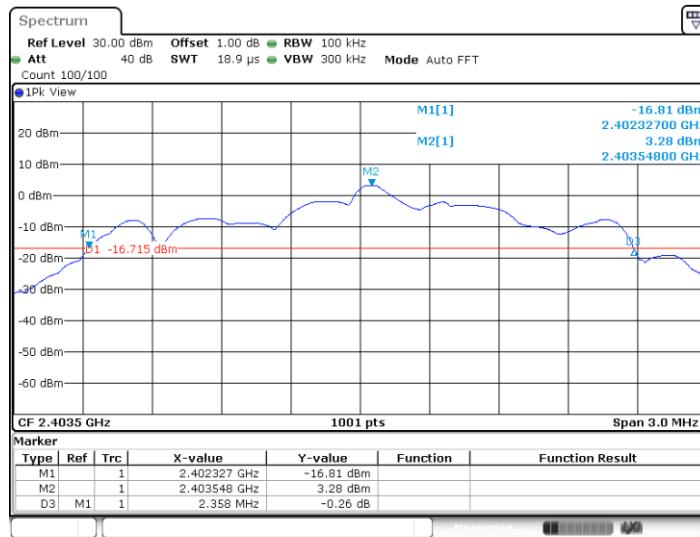

Date: 11.OCT.2021 16:50:32

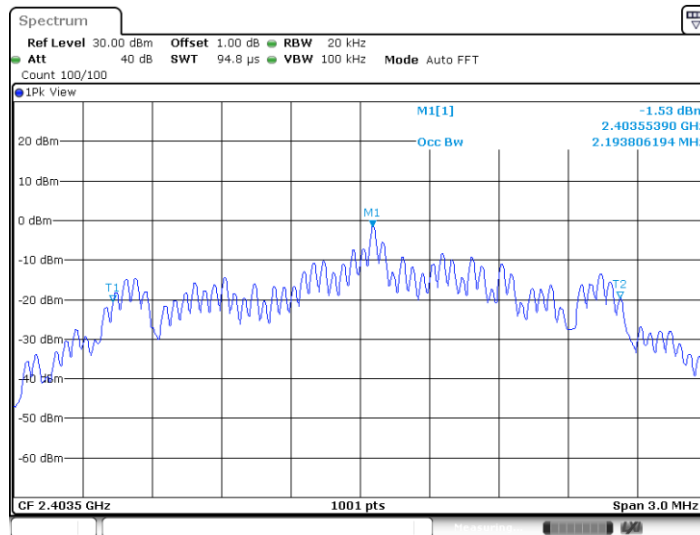

Date: 11.OCT.2021 16:50:43

20 dB bandwidth and 99% Occupied Bandwidth

Middle channel 2440.4MHz

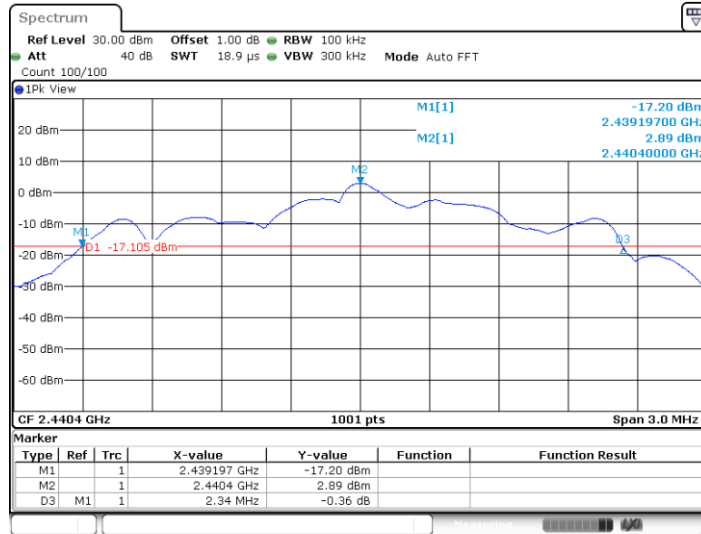

Date: 11.OCT.2021 16:51:36

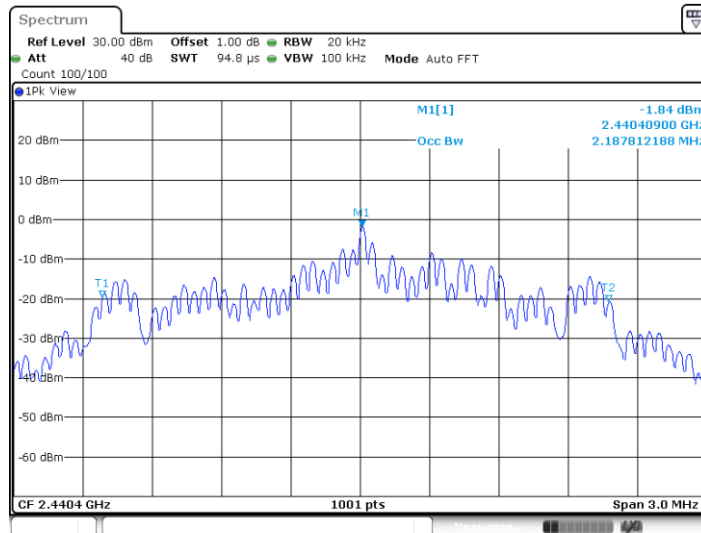

Date: 11.OCT.2021 16:51:47

20 dB bandwidth and 99% Occupied Bandwidth

High channel 2477.3MHz

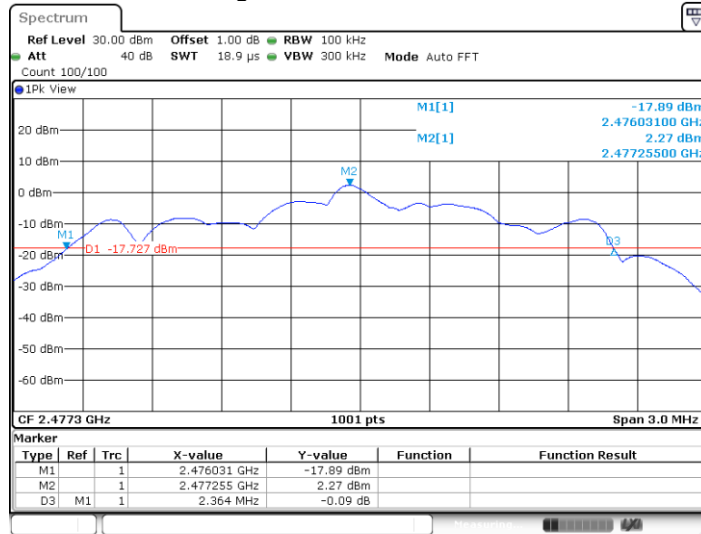

Date: 11.OCT.2021 16:52:18

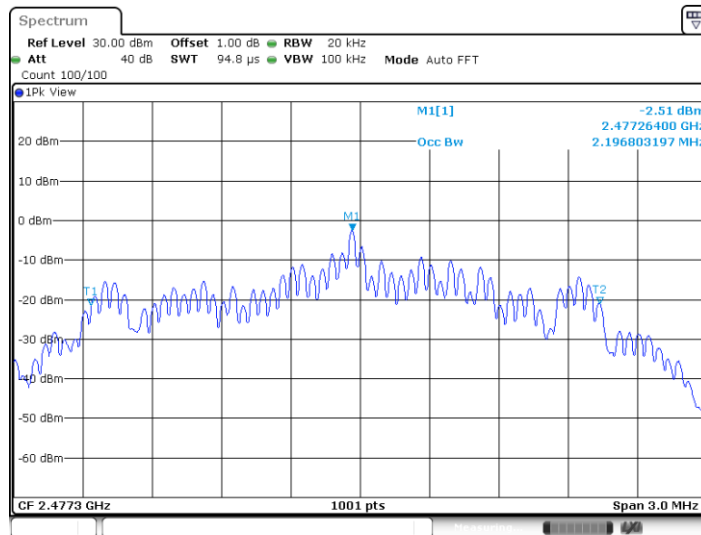

Date: 11.OCT.2021 16:52:28

9.4 Carrier Frequency Separation

Test Method

1. The RF output of EUT was connected to the test receiver by RF cable. The path loss was compensated to the results for each measurement.
2. Set to the maximum power setting and enable the EUT transmit to hopping mode.
3. Use the following spectrum analyzer settings:
Span = wide enough to capture the peaks of two adjacent channels, $RBW \geq 1\%$ of the span, $VBW \geq RBW$, Sweep = auto, Detector function = peak
4. By using the Max-Hold function record the separation of two adjacent channels.
5. Measure the frequency difference of these two adjacent channels by spectrum analyzer marker function. Record the results.
6. Repeat above procedures until all frequencies measured were complete.

Limit

Limit
kHz

 $\geq 25\text{kHz}$ or $2/3$ of the 20 dB bandwidth which is greater

Frequency	2/3 of 20 dB Bandwidth
MHz	kHz
FSK	1460

Carrier Frequency Separation

Test result: The measurement was performed with the typical configuration (normal hopping status).

FSK Modulation test result

Modulation	Frequency MHz	Carrier Frequency Separation KHz	Result
FSK	Hop	1351	Pass

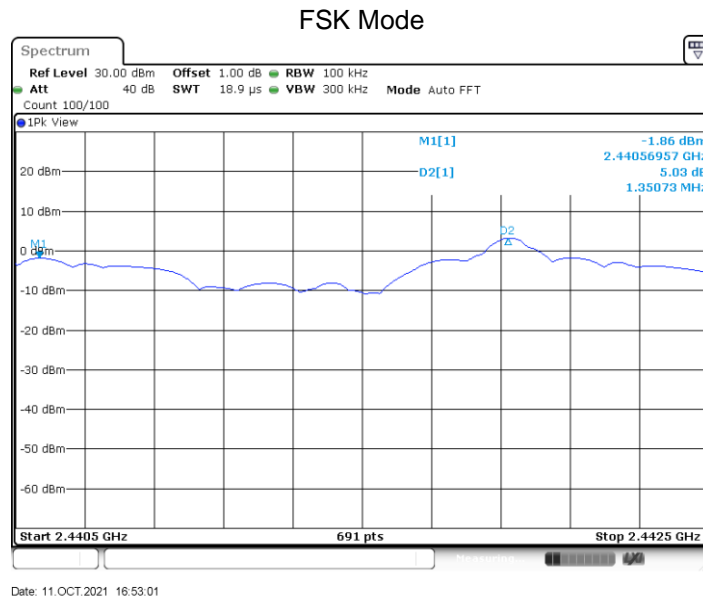

9.5 Number of hopping frequencies

Test Method

1. The RF output of EUT was connected to the test receiver by RF cable. The path loss was compensated to the results for each measurement.
2. Set to the maximum power setting and enable the EUT transmit to hopping mode.
3. Use the following spectrum analyzer settings:
Span = wide enough to capture the peaks of two adjacent channels, $RBW \geq 1\%$ of the span, $VBW \geq RBW$, Sweep = auto, Detector function = peak
4. Set the spectrum analyzer on Max-Hold Mode,
5. Record all the signals from each channel until each one has been recorded.
6. Repeat above procedures until all frequencies measured were complete.

Limit

Limit
number
—————
 ≥ 15

Number of hopping frequencies

Test result: The measurement was performed with the typical configuration (normal hopping status), and the total hopping channels is constant for the all modulation mode according with the Bluetooth Core Specification.

Number of hopping frequencies	Result
15	Pass

FSK Mode

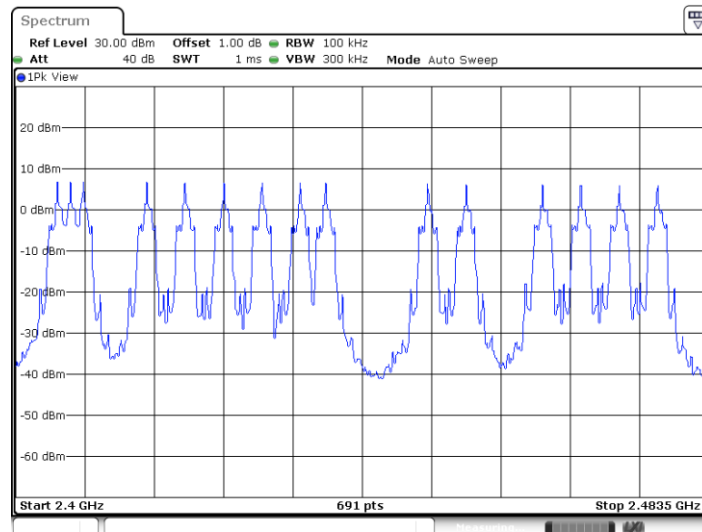

Date: 3 SEP 2021 17:28:22

9.6 Dwell Time

Test Method

1. The RF output of EUT was connected to the test receiver by RF cable. The path loss was compensated to the results for each measurement.
2. Set to the maximum power setting and enable the EUT transmit to hopping mode.
3. Use the following spectrum analyzer settings:
RBW: 1MHz; VBW: 1MHz; SPAN: Zero Span
Set the spectrum analyzer on Max-Hold Mode,
4. Adjust the center frequency of spectrum analyzer on any frequency be measured.
5. Measure the Dwell Time by spectrum analyzer Marker function. Record the results.
Dwell Time = Burst Width * Total Hops
6. Repeat above procedures until all frequencies measured were complete.

Limit

The average time of occupancy on any frequency shall not be greater than 0.4 seconds within a period of 0.4 seconds multiplied by the number of hopping channels employed.

Dwell Time

Dwell time

The maximum dwell time shall be 0.4 s.

The Dwell Time = Burst Width * Total Hops. The detailed calculations are showed as follows:

The duration for dwell time calculation: 0.4 [s] * hopping number = 0.4 [s] * 15 [ch] = 6 [s*ch];

Test Result

Modulation	BurstWidth (ms)	Total Hops	Test Result (s)	Limit (s)	Result
FSK	2.87	60	0.172	0.4	Pass

DH5_Ant1_Hop

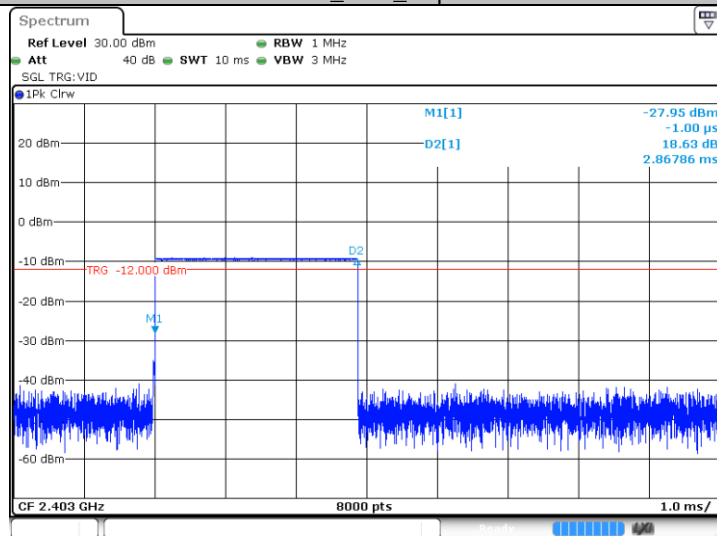

Date: 28 SEP 2021 19:29:45

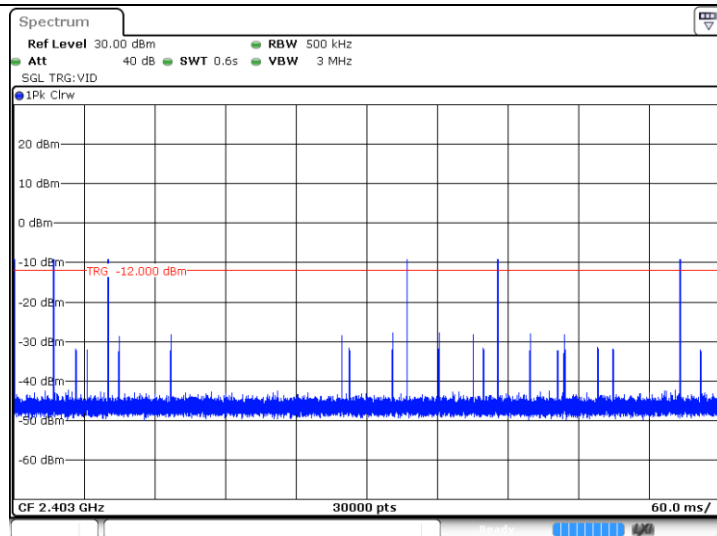

Date: 28 SEP 2021 19:29:50

Remark: Test Result= BurstWidth* Total Hops=2.87*6*10=172.2ms=0.1722s.

9.7 Spurious RF conducted emissions

Test Method

1. The RF output of EUT was connected to the spectrum analyzer by RF cable. The path loss was compensated to the results for each measurement.
2. Set to the maximum power setting and enable the EUT transmit continuously.
3. Set RBW = 100 kHz, VBW=300 kHz, Peak Detector. Unwanted Emissions measured in any 100 kHz bandwidth outside of the authorized frequency band shall be attenuated by at least 20 dB relative to the maximum in-band peak PSD level in 100 kHz when maximum peak conducted output power procedure is used. If the transmitter complies with the conducted power limits based on the use of RMS averaging over a time interval, the attenuation required under this paragraph shall be 30 dB instead of 20 dB.
4. Measure and record the results in the test report.
5. The RF fundamental frequency should be excluded against the limit line in the operating frequency

Limit

Frequency Range MHz	Limit (dBc)
30-25000	-20



Test Result

TestMode	Antenna	Channel[MHz]	FreqRange[MHz]	RefLevel	Result[dBm]	Limit[dBm]	Verdict
DH5	Ant1	2403	Reference	7.70dBm	7.70	---	PASS
			30~1000	30~1000[MHz]	-68.28	<=-12.3	PASS
			1000~26500	1000~26500[MHz]	-32.33	<=-12.3	PASS
		2440	Reference	7.18 dBm	7.18	---	PASS
			30~1000	30~1000[MHz]	-68.38	<=-12.82	PASS
			1000~26500	1000~26500[MHz]	-52.38	<=-12.82	PASS
		2477	Reference	6.70 dBm	6.70	---	PASS
			30~1000	30~1000[MHz]	-67.66	<=-13.3	PASS
			1000~26500	1000~26500[MHz]	-51.57	<=-13.3	PASS

DH5_Ant1_2403_0~Reference



Date: 28 SEP 2021 19:09:46

DH5_Ant1_2403_30~1000

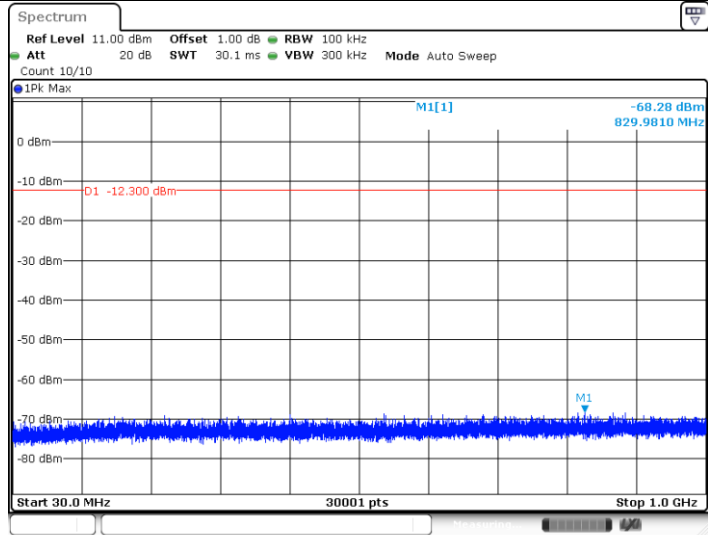

Date: 28 SEP 2021 19:09:52

DH5_Ant1_2403_1000~26500

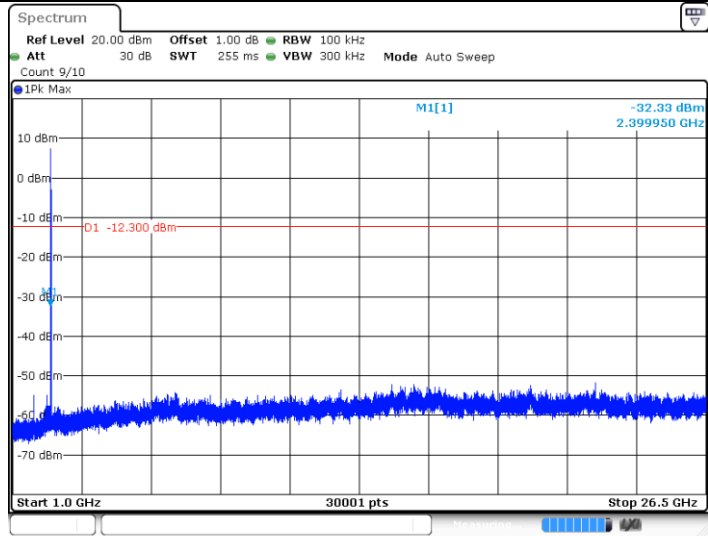

Date: 28 SEP 2021 19:10:00

DH5_Ant1_2440_0~Reference

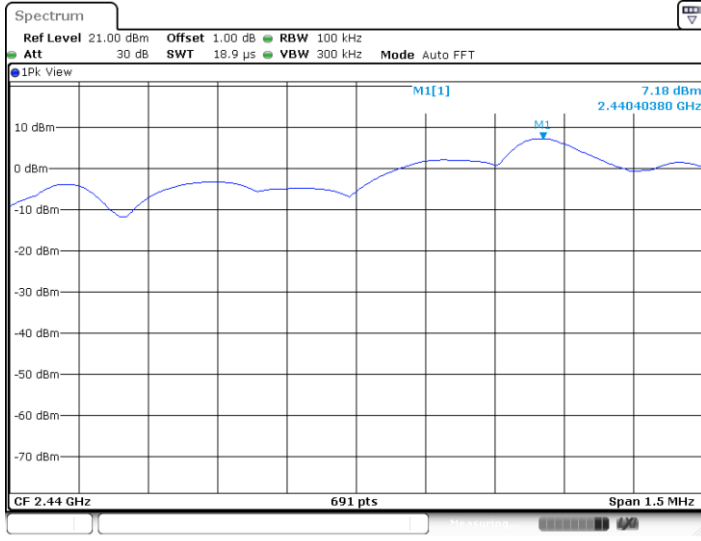

Date: 28 SEP 2021 19:10:18

DH5_Ant1_2440_30~1000

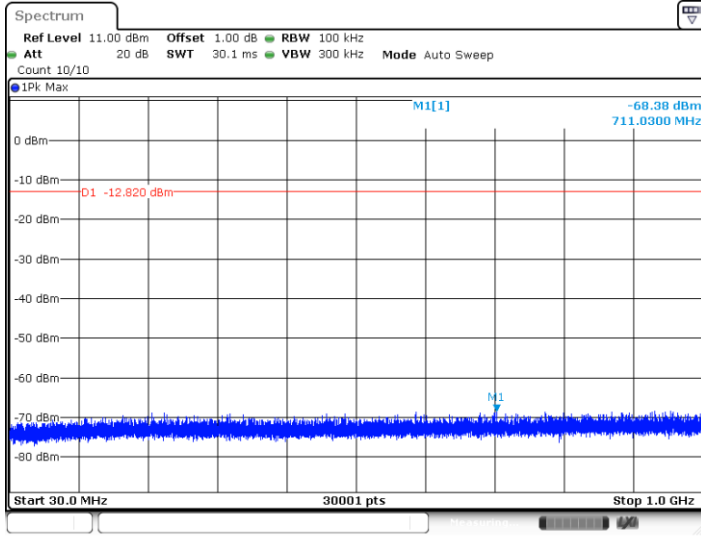

Date: 28 SEP 2021 19:10:24

DH5_Ant1_2440_1000~26500

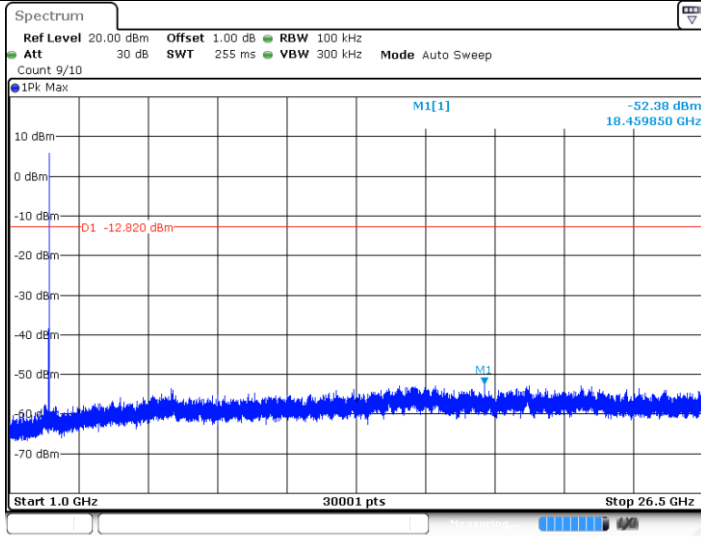

Date: 28 SEP 2021 19:10:32

DH5_Ant1_2477_0~Reference

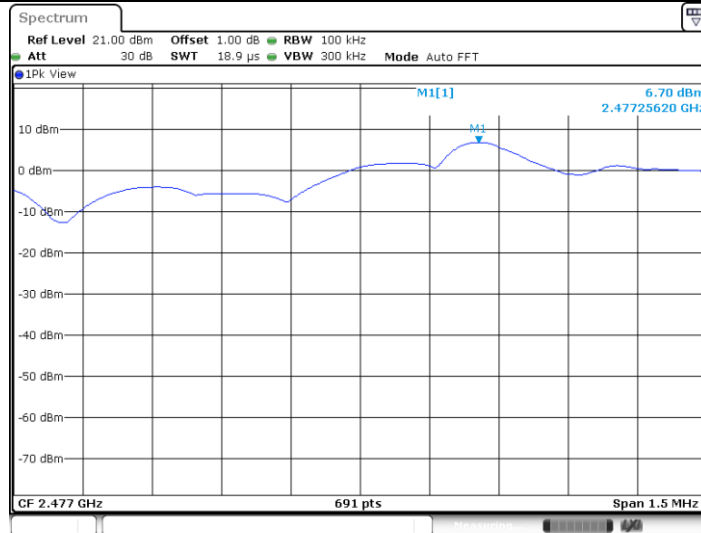

Date: 28 SEP 2021 19:10:48

DH5_Ant1_2477_30~1000

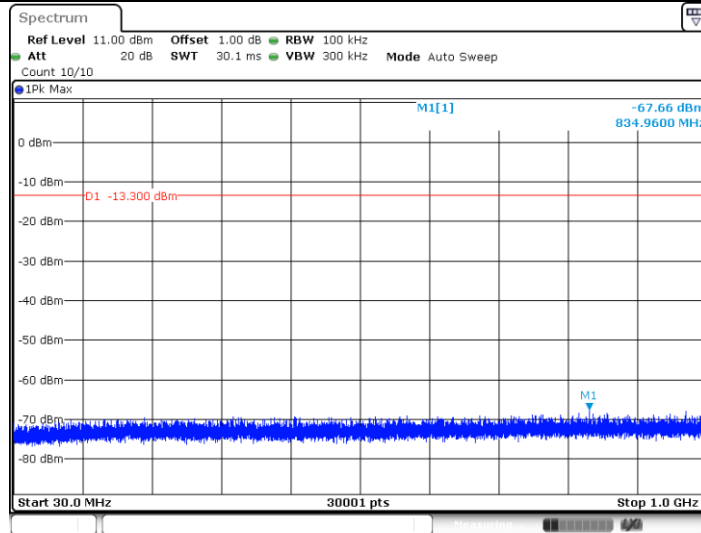

Date: 28 SEP 2021 19:10:54

DH5_Ant1_2477_1000~26500

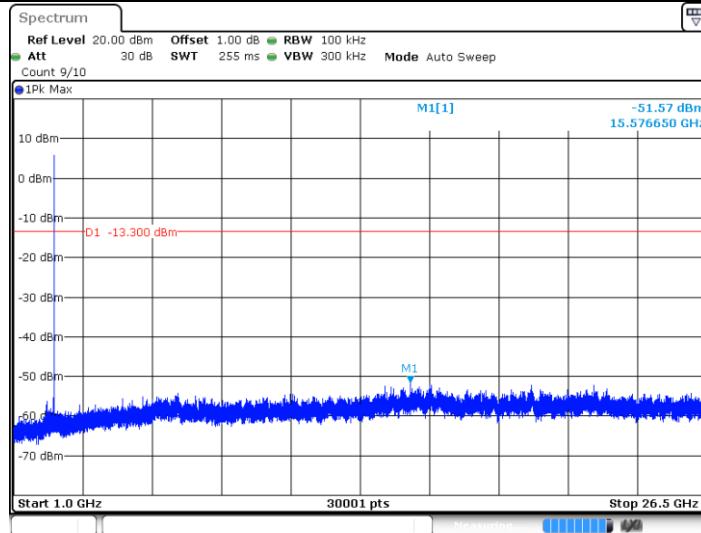

Date: 28 SEP 2021 19:11:02

9.8 Band edge testing

Test Method

1. The RF output of EUT was connected to the spectrum analyzer by RF cable. The path loss was compensated to the results for each measurement.
2. Set to the maximum power setting and enable the EUT transmit continuously.
3. Set RBW = 100 kHz, VBW=300 kHz, Peak Detector. Unwanted Emissions measured in any 100 kHz bandwidth outside of the authorized frequency band shall be attenuated by at least 20 dB relative to the maximum in-band peak PSD level in 100 kHz when maximum peak conducted output power procedure is used. If the transmitter complies with the conducted power limits based on the use of RMS averaging over a time interval, the attenuation required under this paragraph shall be 30 dB instead of 20 dB.
4. Measure and record the results in the test report.
5. The RF fundamental frequency should be excluded against the limit line in the operating frequency
6. Set to the maximum power setting and enable the EUT hopping mode, repeat the test.

Limit:

In any 100kHz bandwidth outside the frequency band in which the spread spectrum or digitally modulated device is operating, the RF power that is produced shall be at least 20 dB below that in the 100 kHz bandwidth within the band that contains the highest level of the desired power, based on either an RF conducted or a radiated measurement, provided that the transmitter demonstrates compliance with the peak conducted power limits.

Test Result

TestMode	Antenna	ChName	Channel[MHz]	RefLevel[dBm]	Result[dBm]	Limit[dBm]	Verdict
DH5	Ant1	Low	2403	7.72	-38.5	<=-12.28	PASS
		High	2477	6.65	-55.32	<=-13.35	PASS
		Low	Hop_2402	8.03	-54.83	-11.97	PASS
		High	Hop_2480	7.13	-50.84	-12.87	PASS

DH5_Ant1_Low_2403

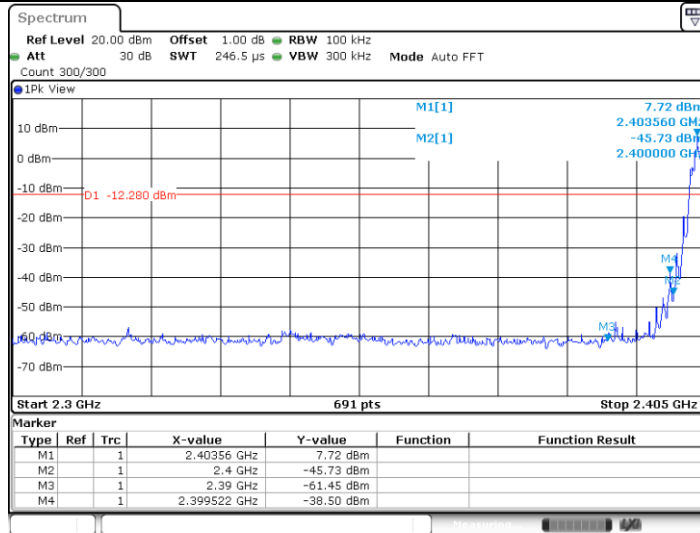

DH5_Ant1_High_2477

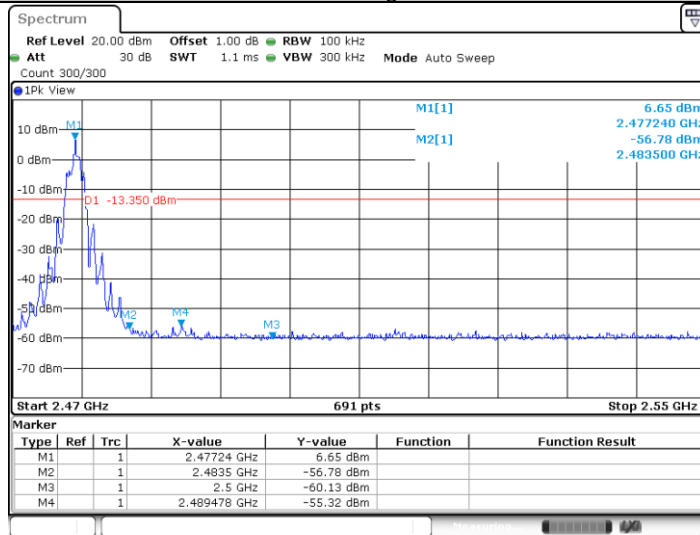

DH5_Ant1_Low_Hop_2402

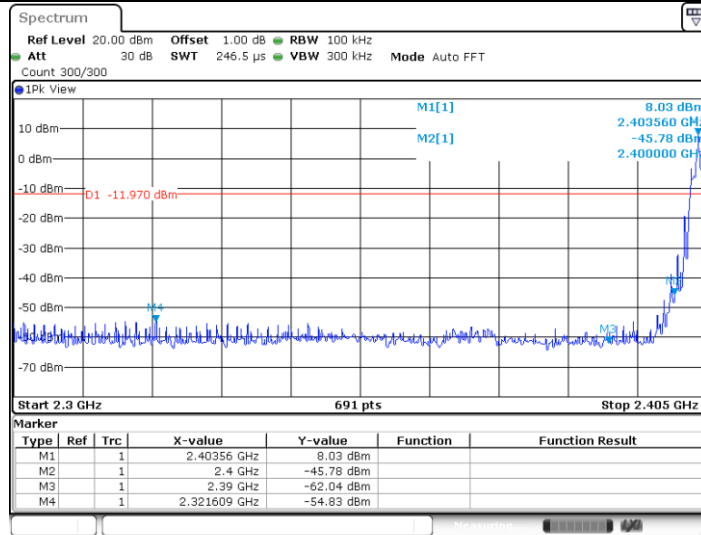

Date: 28 SEP 2021 19:18:35

DH5_Ant1_High_Hop_2480

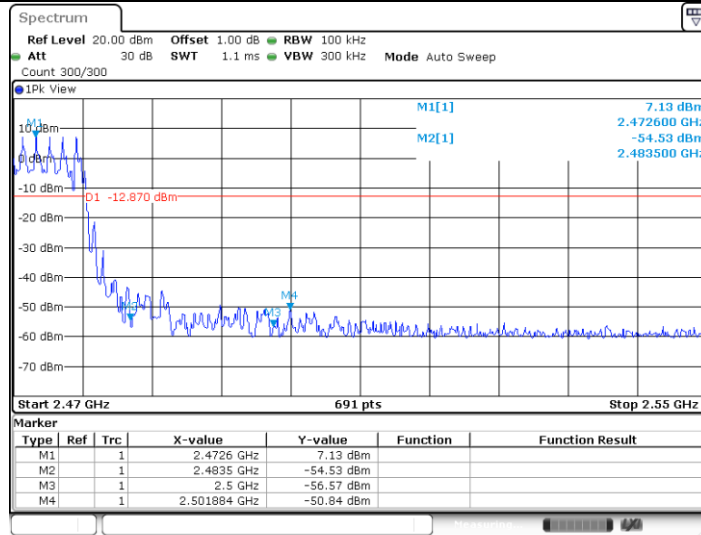

Date: 28 SEP 2021 19:18:46

2403.5MHz
Horizontal:

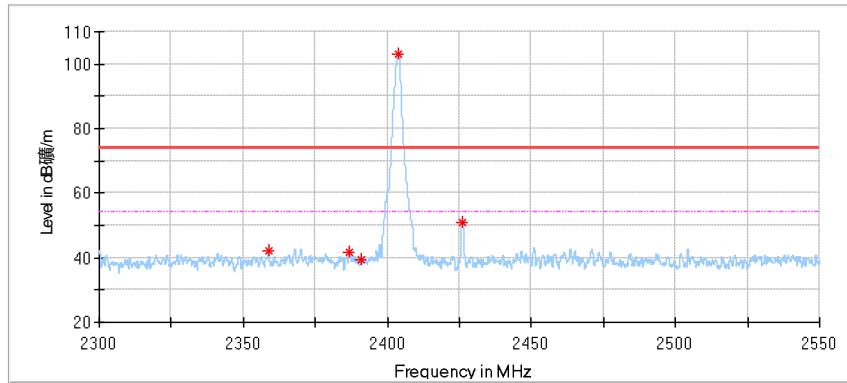

Frequency (MHz)	MaxPeak (dBµV/m)	Limit (dBµV/m)	Margin (dB)	Height (cm)	Pol	Azimuth (deg)	Corr. (dB/m)
2358.690476	41.95	74.00	32.05	150.0	H	211.0	-3.10
2386.964286	41.66	74.00	32.34	150.0	H	252.0	-3.05
2390.833333	39.58	74.00	34.42	150.0	H	306.0	-3.06
2403.988095	103.28	74.00	-29.28	150.0	H	282.0	-3.07
2426.011905	50.92	74.00	23.08	150.0	H	318.0	-3.02

Vertical

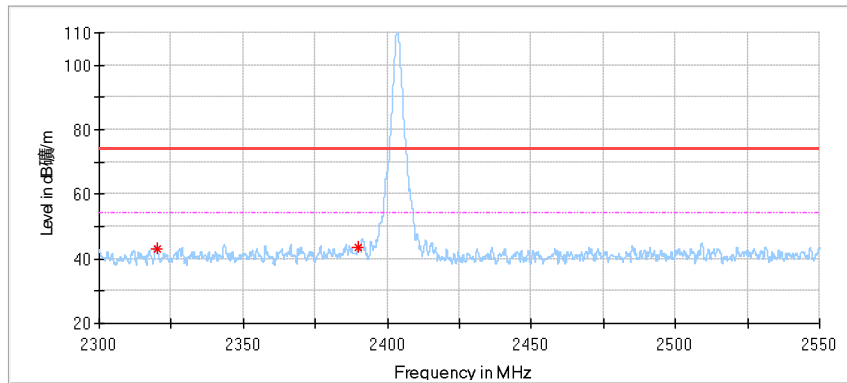

Frequency (MHz)	MaxPeak (dBµV/m)	Limit (dBµV/m)	Margin (dB)	Height (cm)	Pol	Azimuth (deg)	Corr. (dB/m)
2320.238095	42.86	74.00	31.14	150.0	V	214.0	-3.23
2390.000000	43.39	74.00	30.61	150.0	V	275.0	-3.06
2403.511905	110.49	74.00	-36.49	150.0	V	208.0	-3.07

2477MHz
Horizontal:

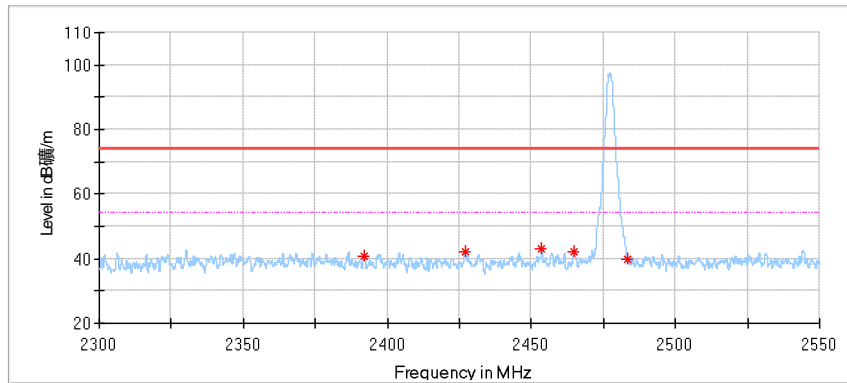

Frequency (MHz)	MaxPeak (dBµV/m)	Limit (dBµV/m)	Margin (dB)	Height (cm)	Pol	Azimuth (deg)	Corr. (dB/m)
2391.904762	40.65	74.00	33.35	150.0	H	57.0	-3.06
2427.083333	41.97	74.00	32.03	150.0	H	233.0	-3.01
2453.452381	43.21	74.00	30.79	150.0	H	219.0	-2.88
2464.761905	42.20	74.00	31.80	150.0	H	267.0	-2.78
2483.511905	39.70	74.00	34.30	150.0	H	57.0	-2.70

Vertical

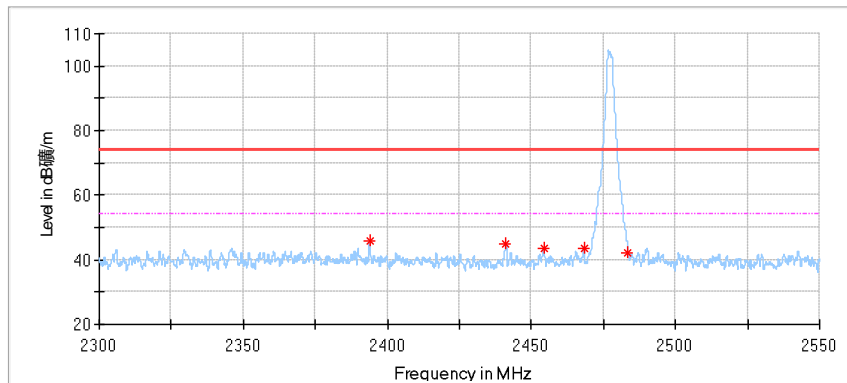

Frequency (MHz)	MaxPeak (dBµV/m)	Limit (dBµV/m)	Margin (dB)	Height (cm)	Pol	Azimuth (deg)	Corr. (dB/m)
2393.809524	45.94	74.00	28.06	150.0	V	69.0	-3.07
2441.190476	44.75	74.00	29.25	150.0	V	0.0	-2.95
2454.226191	43.68	74.00	30.32	150.0	V	0.0	-2.87
2468.154762	43.76	74.00	30.24	150.0	V	174.0	-2.75
2483.511905	42.02	74.00	31.98	150.0	V	350.0	-2.70

9.9 Spurious radiated emissions for transmitter

Test Method

- 1: The EUT was placed on a turn table which is 1.5m above ground plane for above 1GHz and 0.8m above ground for below 1GHz at 3-meter chamber room for test. The table was rotated 360 degrees to determine the position of the highest radiation.
- 2: The EUT was set 3 meters away from the interference – receiving antenna, which was mounted on the top of a variable – height antenna tower.
- 3: The height of antenna is varied from one meter to four meters above the ground to determine the maximum value of the field strength. Both horizontal and vertical polarizations of the antenna are set to make the measurement.
- 4: For each suspected emission, the EUT was arranged to its worst case and then the antenna was tuned to heights from 1 meter to 4 meters and the rotatable table was turned from 0 degrees to 360 degrees to find the maximum reading.
- 5: Use the following spectrum analyzer settings According to C63.10:

For Below 1GHz

Use the following spectrum analyzer settings:

Span = wide enough to capture the peak level of the in-band emission and all spurious
RBW = 100 KHz to 120KHz, VBW \geq RBW for peak measurement, Sweep = auto,
Detector function = peak, Trace = max hold.

For Peak unwanted emissions Above 1GHz:

Span = wide enough to capture the peak level of the in-band emission and all spurious
RBW = 1MHz, VBW \geq RBW for peak measurement, Sweep = auto,
Detector function = peak, Trace = max hold.

Procedures for average unwanted emissions measurements above 1000 MHz:

Span = wide enough to capture the peak level of the in-band emission and all spurious
RBW = 1MHz, VBW=10Hz, Sweep = auto, Detector function = peak, Trace = max hold.
If the dwell time per channel of the hopping signal is less than 100 ms, then the reading obtained with the 10 Hz VBW may be further adjusted by a “duty cycle correction factor”, derived from $20\log(\text{dwell time}/100 \text{ ms})$, in an effort to demonstrate compliance with the limit.

If the emission is pulsed, modify the unit for continuous operation; use the settings shown above, then correct the reading by subtracting the peak-average correction factor, derived from the appropriate duty cycle calculation.

Limit

The radio emission outside the operating frequency band shall be at least 20 dB below that in the 100 kHz bandwidth within the band that contains the highest level of the desired power. Radiated emissions which fall in the restricted bands, as defined in section 15.205 and RSS-GEN 8.10, must comply with the radiated emission limits specified in section 15.209.

Frequency MHz	Field Strength uV/m	Field Strength dBµV/m	Detector
30-88	100	40	QP
88-216	150	43.5	QP
216-960	200	46	QP
960-1000	500	54	QP
Above 1000	500	54	AV
Above 1000	5000	74	PK

Spurious radiated emissions for transmitter

According to C63.10, if the peak (or quasi-peak) measured value complies with the average limit, it is unnecessary to perform an average measurement, so AV emission value did not show in below table if the peak value complies with average limit.

The only worse case (FSK mode) test result is listed in the report.

30MHz to 1000MHz:

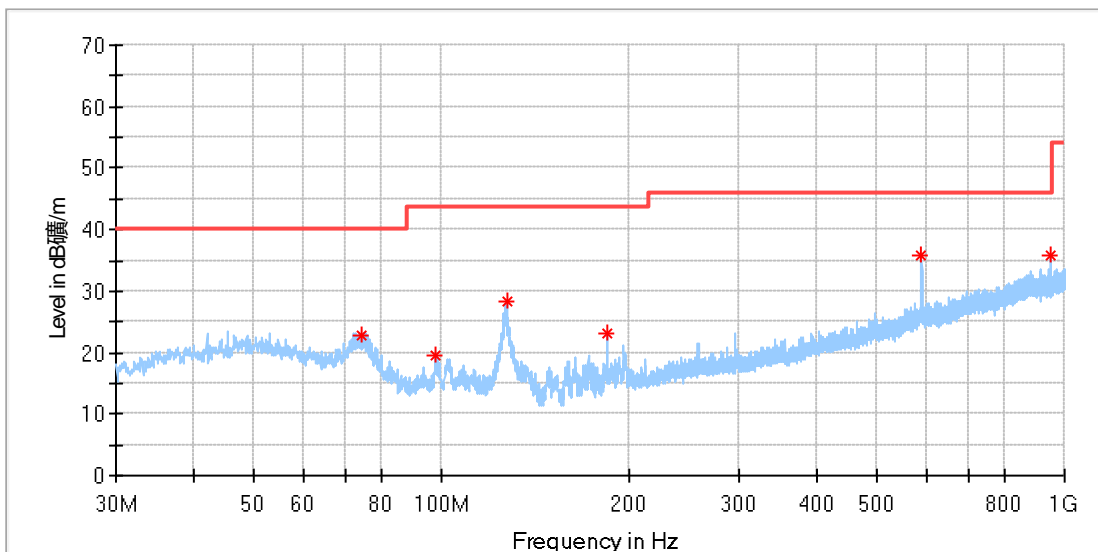

Frequency (MHz)	MaxPeak (dBµV/m)	Limit (dBµV/m)	Margin (dB)	Height (cm)	Pol	Azimuth (deg)	Corr. (dB/m)
74.620000	22.94	40.00	17.06	200.0	H	346.0	8.99
98.081875	19.47	43.50	24.03	200.0	H	0.0	12.91
127.121250	28.29	43.50	15.21	200.0	H	196.0	10.48
184.290625	23.04	43.50	20.46	100.0	H	0.0	11.62
589.811250	35.71	46.00	10.29	100.0	H	29.0	22.33
948.590000	35.82	46.00	10.18	100.0	H	0.0	27.11

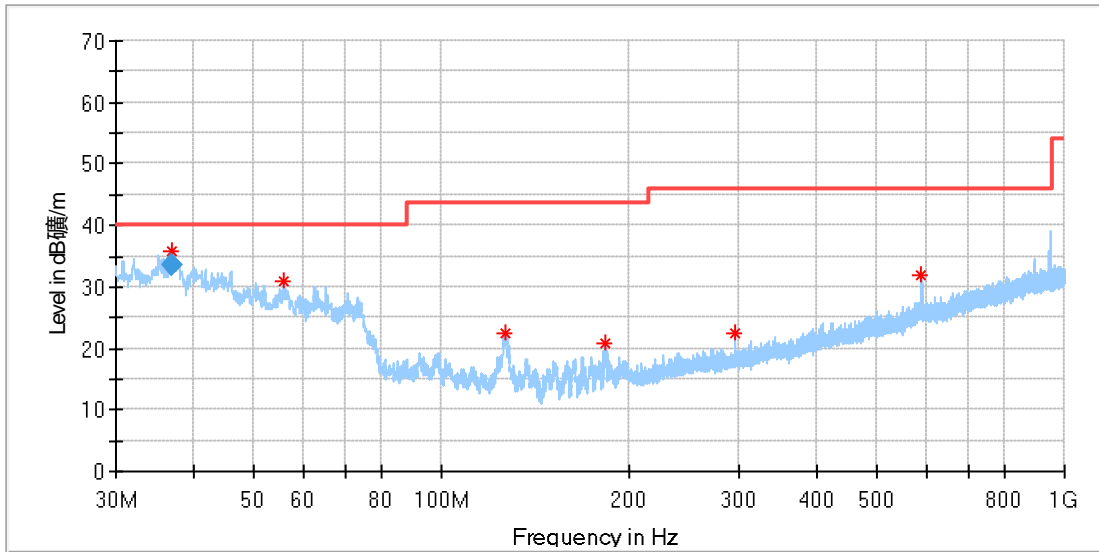

Frequency (MHz)	MaxPeak (dBµV/m)	Limit (dBµV/m)	Margin (dB)	Height (cm)	Pol	Azimuth (deg)	Corr. (dB/m)
36.971875	35.68	40.00	4.32	100.0	V	172.0	12.88
55.826250	30.85	40.00	9.15	100.0	V	0.0	14.74
126.818125	22.32	43.50	21.18	100.0	V	0.0	10.49
182.653750	20.78	43.50	22.72	100.0	V	135.0	11.43
294.870625	22.55	46.00	23.45	200.0	V	0.0	15.33
589.871875	32.02	46.00	13.98	100.0	V	78.0	22.33
Frequency	QuasiPeak	Limit	Margin	Height	Pol	Azimuth	Corr.
36.971875	33.42	40.00	6.58	100.0	V	172.0	12.88

1GHz -18GHz:
FSK_2403.5MHz
Horizontal:

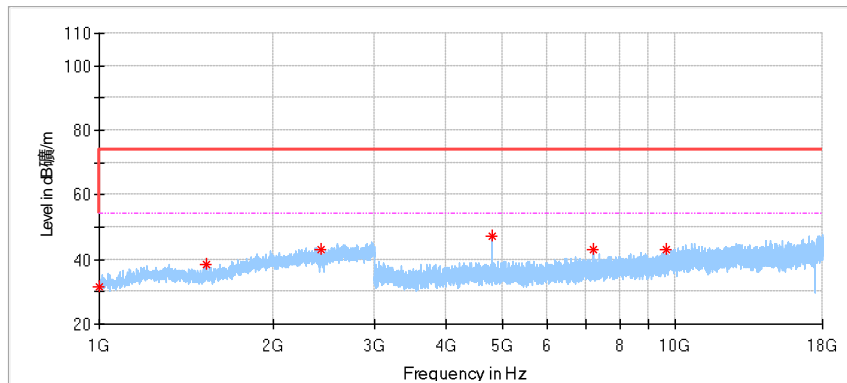

Frequency (MHz)	MaxPeak (dBµV/m)	Limit (dBµV/m)	Margin (dB)	Height (cm)	Pol	Azimuth (deg)	Corr. (dB/m)
1000.000000	31.63	54.00	42.37	150.0	H	195.0	-11.07
1537.142857	38.37	74.00	35.63	150.0	H	45.0	-8.36
2419.047619	43.07	74.00	30.93	150.0	H	335.0	-2.07
4808.000000	47.33	74.00	26.67	150.0	H	63.0	3.47
7212.500000	43.23	74.00	30.77	150.0	H	32.0	7.06
9612.500000	43.07	74.00	30.93	150.0	H	152.0	9.31

Vertical

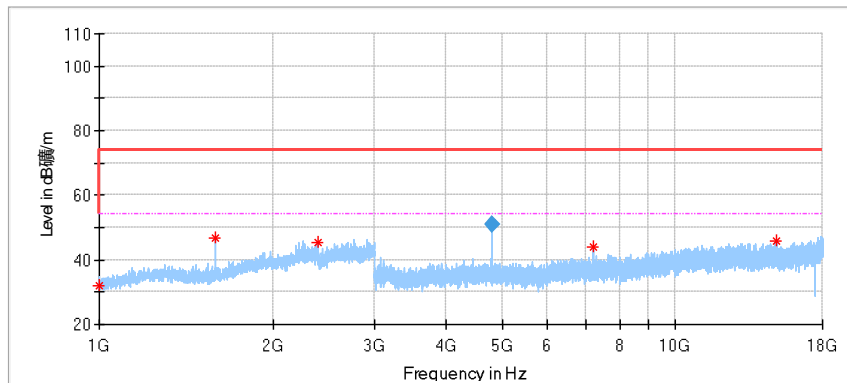

Frequency (MHz)	MaxPeak (dBµV/m)	Limit (dBµV/m)	Margin (dB)	Height (cm)	Pol	Azimuth (deg)	Corr. (dB/m)
1000.000000	31.82	54.00	42.18	150.0	V	261.0	-11.07
1593.333333	46.55	74.00	27.45	150.0	V	41.0	-7.90
2391.904762	45.33	74.00	28.67	150.0	V	173.0	-2.16
4806.000000	51.21	74.00	22.79	150.0	V	122.0	3.47
7209.500000	43.85	74.00	30.15	150.0	V	350.0	7.05
14969.000000	45.95	74.00	28.05	150.0	V	297.0	13.51
Frequency	Average	Limit	Margin	Height	Pol	Azimuth	Corr.
4806.000000	50.91	54.00	3.09	150.0	V	122.0	3.47

FSK_2440.4MHz
Horizontal:

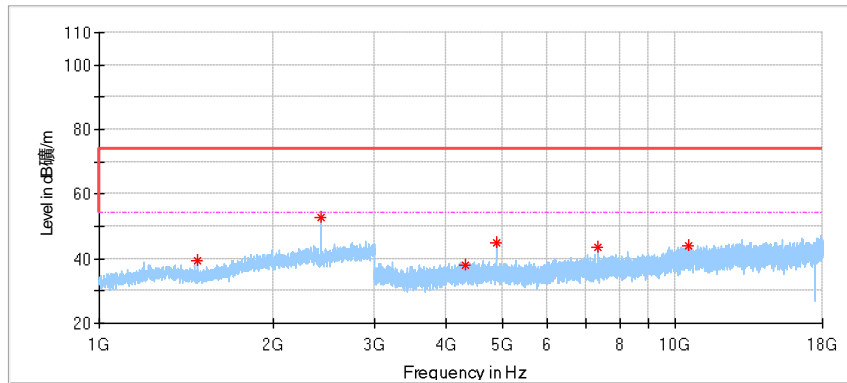

Frequency (MHz)	MaxPeak (dBµV/m)	Limit (dBµV/m)	Margin (dB)	Height (cm)	Pol	Azimuth (deg)	Corr. (dB/m)
1480.952381	39.40	74.00	34.60	150.0	H	67.0	-8.51
2426.666667	52.91	74.00	21.09	150.0	H	155.0	-2.04
4330.000000	38.10	74.00	35.90	150.0	H	211.0	2.35
4881.500000	45.14	74.00	28.86	150.0	H	92.0	3.61
7320.000000	43.34	74.00	30.66	150.0	H	305.0	7.21
10549.500000	43.87	74.00	30.13	150.0	H	32.0	10.44

Vertical

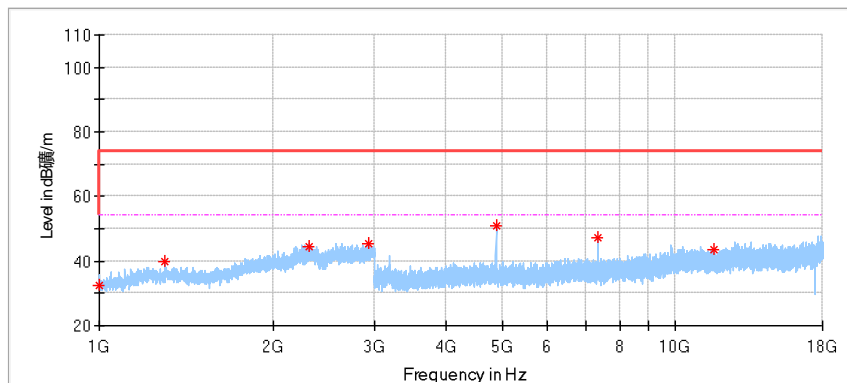

Frequency (MHz)	MaxPeak (dBµV/m)	Limit (dBµV/m)	Margin (dB)	Height (cm)	Pol	Azimuth (deg)	Corr. (dB/m)
1000.000000	32.32	54.00	41.69	150.0	V	342.0	-11.07
1301.428571	40.03	74.00	33.97	150.0	V	97.0	-7.71
2308.095238	44.51	74.00	29.49	150.0	V	192.0	-2.38
2929.047619	45.51	74.00	28.49	150.0	V	214.0	-0.64
4881.500000	50.89	74.00	23.11	150.0	V	122.0	3.61
7322.500000	47.37	74.00	26.63	150.0	V	32.0	7.21
11668.500000	43.54	74.00	30.46	150.0	V	122.0	11.10

FSK_2477.3MHz
Horizontal:

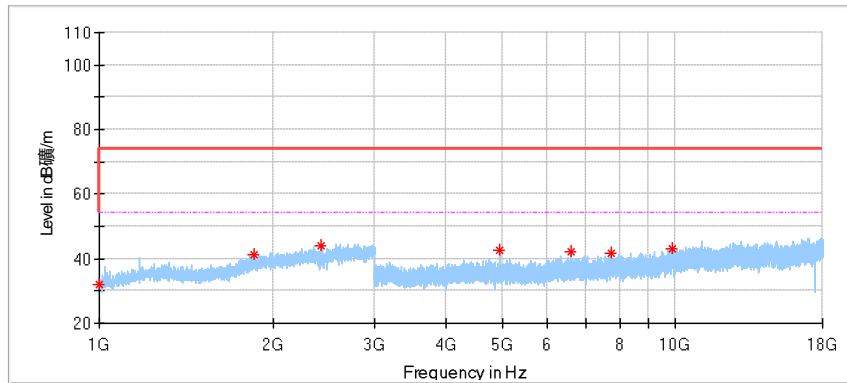

Frequency (MHz)	MaxPeak (dBµV/m)	Limit (dBµV/m)	Margin (dB)	Height (cm)	Pol	Azimuth (deg)	Corr. (dB/m)
1000.000000	32.10	54.00	41.90	150.0	H	276.0	-11.07
1855.238095	41.02	74.00	32.98	150.0	H	261.0	-4.59
2426.666667	43.98	74.00	30.02	150.0	H	283.0	-2.04
4955.000000	42.54	74.00	31.46	150.0	H	127.0	3.70
6607.000000	42.10	74.00	31.90	150.0	H	97.0	6.59
7723.500000	41.86	74.00	32.14	150.0	H	32.0	8.00
9900.500000	43.16	74.00	30.84	150.0	H	186.0	10.57

Vertical

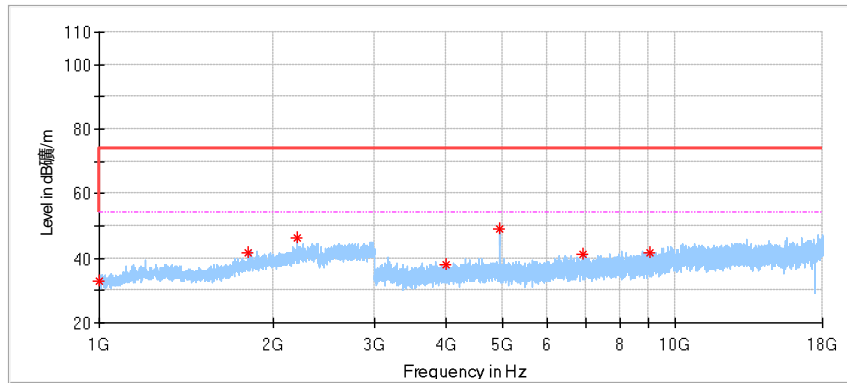

Frequency (MHz)	MaxPeak (dBµV/m)	Limit (dBµV/m)	Margin (dB)	Height (cm)	Pol	Azimuth (deg)	Corr. (dB/m)
1000.000000	32.73	54.00	41.27	150.0	V	135.0	-11.07
1817.619048	41.80	74.00	32.20	150.0	V	291.0	-5.01
2206.666667	46.15	74.00	27.85	150.0	V	210.0	-2.89
4001.000000	37.81	74.00	36.19	150.0	V	209.0	1.31
4955.500000	49.13	74.00	24.87	150.0	V	92.0	3.70
6916.000000	41.01	74.00	32.99	150.0	V	63.0	6.81
9046.000000	41.86	74.00	32.14	150.0	V	4.0	8.88

Above 18GHz:

FSK_2403.5MHz

Horizontal:

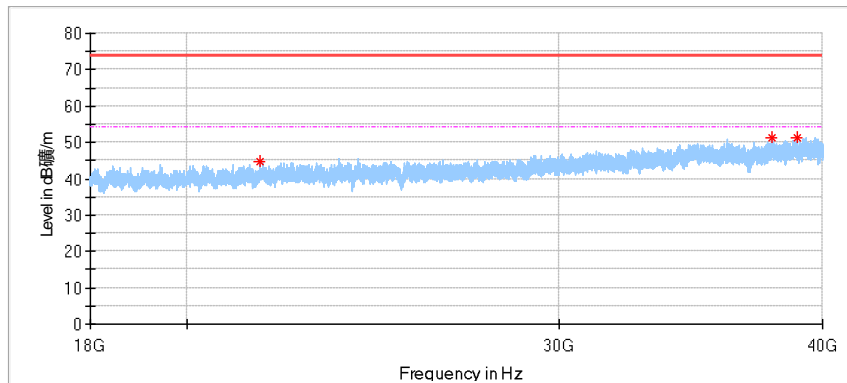

Frequency (MHz)	MaxPeak (dBµV/m)	Limit (dBµV/m)	Margin (dB)	Height (cm)	Pol	Azimuth (deg)	Corr. (dB/m)
21665.062500	44.59	74.00	29.41	150.0	H	142.0	1.6
37839.875000	51.47	74.00	22.53	150.0	H	356.0	8.7
38893.125000	51.18	74.00	22.82	150.0	H	188.0	9.8

Vertical

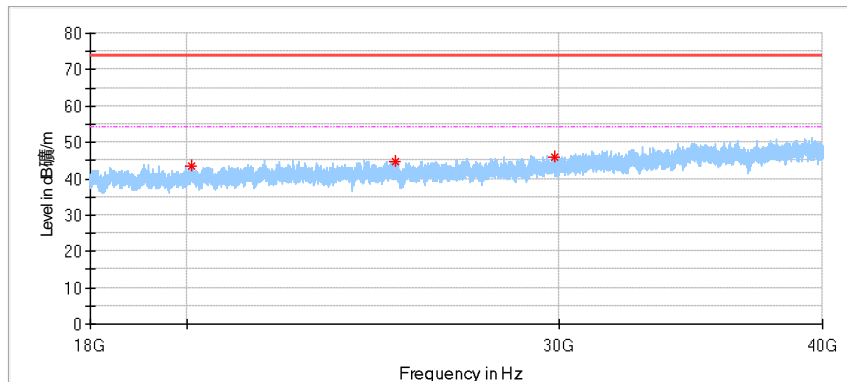

Frequency (MHz)	MaxPeak (dBµV/m)	Limit (dBµV/m)	Margin (dB)	Height (cm)	Pol	Azimuth (deg)	Corr. (dB/m)
20095.500000	43.66	74.00	30.34	150.0	V	82.0	-0.1
25094.312500	44.89	74.00	29.11	150.0	V	355.0	3.5
29844.250000	46.10	74.00	27.90	150.0	V	17.0	3.7

FSK_2440.4MHz
Horizontal:

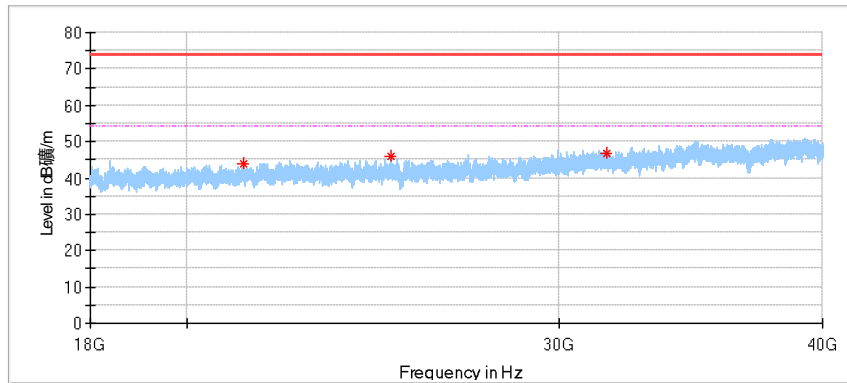

Frequency (MHz)	MaxPeak (dBµV/m)	Limit (dBµV/m)	Margin (dB)	Height (cm)	Pol	Azimuth (deg)	Corr. (dB/m)
21267.687500	43.70	74.00	30.30	150.0	H	15.0	1.3
24984.312500	46.00	74.00	28.00	150.0	H	75.0	3.7
31596.000000	46.63	74.00	27.37	150.0	H	295.0	4.4

Vertical

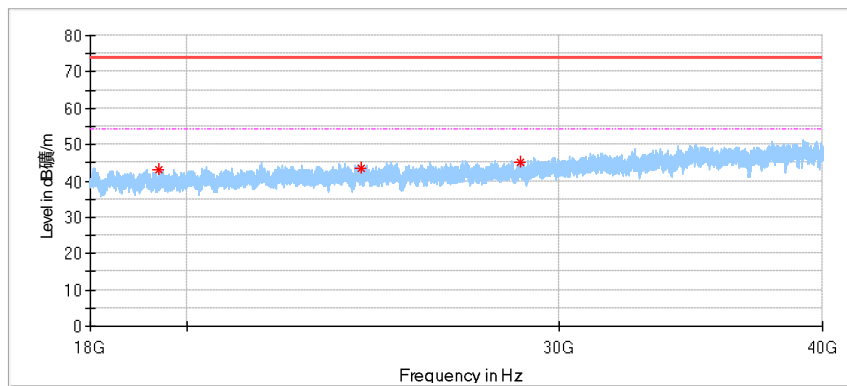

Frequency (MHz)	MaxPeak (dBµV/m)	Limit (dBµV/m)	Margin (dB)	Height (cm)	Pol	Azimuth (deg)	Corr. (dB/m)
19409.375000	43.06	74.00	30.95	150.0	V	285.0	-0.9
24177.875000	43.59	74.00	30.41	150.0	V	178.0	2.5
28784.125000	45.06	74.00	28.94	150.0	V	15.0	3.8

FSK_2477.3MHz
Horizontal:

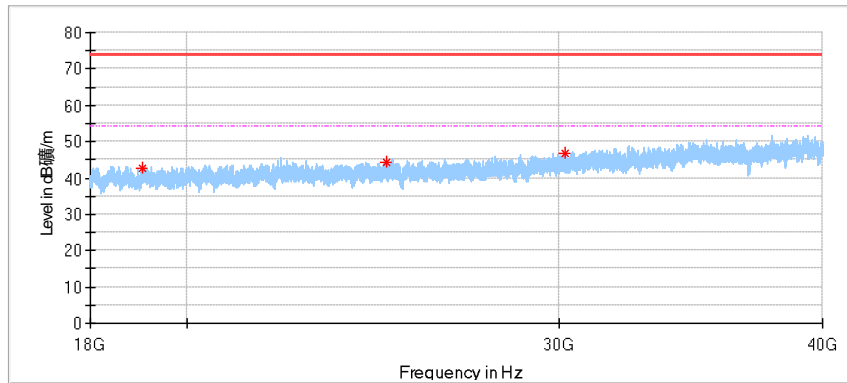

Frequency (MHz)	MaxPeak (dBµV/m)	Limit (dBµV/m)	Margin (dB)	Height (cm)	Pol	Azimuth (deg)	Corr. (dB/m)
19066.312500	42.75	74.00	31.25	150.0	H	254.0	-0.8
24846.125000	44.38	74.00	29.62	150.0	H	15.0	3.5
30232.000000	46.76	74.00	27.24	150.0	H	359.0	3.8

Vertical

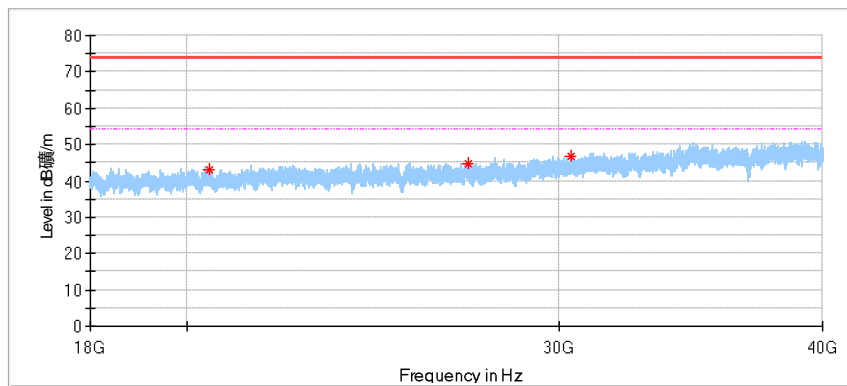

Frequency (MHz)	MaxPeak (dBµV/m)	Limit (dBµV/m)	Margin (dB)	Height (cm)	Pol	Azimuth (deg)	Corr. (dB/m)
20501.125000	43.09	74.00	30.91	150.0	V	109.0	0.3
27163.687500	44.85	74.00	29.15	150.0	V	216.0	3.9
30422.437500	46.70	74.00	27.30	150.0	V	1.0	3.9

Remark:

- (1) Data of measurement within this frequency range shown "--" in the table above means the reading of emissions are the noise floor or attenuated more than 10dB below the permissible limits or the field strength is too small to be measured.
- (2) Level= Reading Level + Correction Factor
- (3) Above 1GHz: Corrector factor = Antenna Factor + Cable Loss- Amplifier Gain
Below 1GHz: Corrector factor = Antenna Factor + Cable Loss
(The Reading Level is recorded by software which is not shown in the sheet)

10 Test Equipment List

Conducted Emission Test

Description	Manufacturer	Model no.	Serial no.	cal. due date
EMI Test Receiver	Rohde & Schwarz	ESR 3	101782	2022-6-4
LISN	Rohde & Schwarz	ENV4200	100249	2022-6-5
Attenuator	Shanghai Huaxiang	TS2-26-3	080928189	2022-6-5
Test software	Rohde & Schwarz	EMC32	Version9.15.00	N/A

Radiated Emission Test

DESCRIPTION	MANUFACTURER	MODEL NO.	SERIAL NO.	CAL. DUE DATE
EMI Test Receiver	Rohde & Schwarz	ESR 26	101269	2022-6-4
Trilog Super Broadband Test Antenna	Schwarzbeck	VULB 9163	707	2022-2-2
Wave Guide Antenna	ETS	3117	68-4-80-19-001	2022-5-24
Sideband Horn Antenna	Q-PAR	QWH-SL-18-40-K-SG	68-4-80-14-008	2021-8-5
Pre-amplifier	Rohde & Schwarz	SCU 18F	68-4-29-19-001	2021-10-25
Pre-amplifier	Rohde & Schwarz	SCU 08F2	68-4-29-19-004	2021-10-25
Pre-amplifier	Rohde & Schwarz	SCU 40A	68-4-29-14-002	2022-7-27
3m Semi-anechoic chamber	TDK	9X6X6	----	2022-12-29

RF conducted test

DESCRIPTION	MANUFACTURER	MODEL NO.	SERIAL NO.	CAL. DUE DATE
Signal Analyzer	Rohde & Schwarz	FSV40	101030	2022-6-3
RF Switch Module	Rohde & Schwarz	OSP120/OSP-B157	101226/100851	2022-6-3
Power Splitter	Weinschel	1580	SC319	2022-6-3
Test software	Tonscend	System for BT/WIFI	Version 2.5.77.0418	N/A

11 System Measurement Uncertainty

For a 95% confidence level, the measurement expanded uncertainties for defined systems, in accordance with the recommendations of ISO 17025 were:

System Measurement Uncertainty	
Test Items	Extended Uncertainty
Uncertainty for Conducted Emission 150kHz-30MHz (for test using AMN ENV432 or ENV4200)	3.62dB
Uncertainty for Radiated Spurious Emission 25MHz-3000MHz	Horizontal: 4.70dB; Vertical: 4.67dB;
Uncertainty for Radiated Spurious Emission 3000MHz-18000MHz	Horizontal: 4.65dB; Vertical: 4.63dB;
Uncertainty for Radiated Spurious Emission 18000MHz-40000MHz	Horizontal: 5.05dB; Vertical: 5.04dB;
Uncertainty for Conducted RF test with TS 8997	RF Power Conducted: 1.16dB Frequency test involved: 0.6×10^{-7} or 1%
Uncertainty Evaluation for Humidity	0.936%
Uncertainty Evaluation for Temperature	0.195 °C

---The End---