

Report No.: SEWM2311000466RG08

Rev.: 01

Page: 1 of 37

## HAC (T-Coil) Test Report

**Application No.:** SEWM2311000466RG  
**Applicant:** COOSEA GROUP (HK) COMPANY LIMITED  
**Manufacturer:** COOSEA GROUP (HK) COMPANY LIMITED  
**Product Name:** Smart Phone  
**Model No.(EUT):** SN339D  
**FCC ID:** 2A28USN339D  
**Standards:** ANSI C63.19-2019  
CFR 47 FCC Part 20  
**Date of Receipt:** 2023-11-17  
**Date of Test:** 2023-11-18 to 2024-01-26  
**Date of Issue:** 2024-01-30  
**Test conclusion:** **PASS \***

\* In the configuration tested, the EUT detailed in this report complied with the standards specified above.

Authorized Signature:

Well Wei

Wireless Laboratory Manager



SGS-CSTC Standards Technical Services (Suzhou) Co., Ltd.  
Wireless Laboratory

Unless otherwise agreed in writing, this document is issued by the Company subject to its General Conditions of Service printed overleaf, available on request or accessible at <http://www.sgs.com/en/Terms-and-Conditions.aspx> and, for electronic format documents, subject to Terms and Conditions for Electronic Documents at <http://www.sgs.com/en/Terms-and-Conditions/Terms-e-Documents.aspx>. Attention is drawn to the limitation of liability, indemnification and jurisdiction issues defined therein. Any holder of this document is advised that information contained hereon reflects the Company's findings at the time of its intervention only and within the limits of Client's instructions, if any. The Company's sole responsibility is to its Client and this document does not exonerate parties to a transaction from exercising all their rights and obligations under the transaction documents. This document cannot be reproduced except in full, without prior written approval of the Company. Any unauthorized alteration, forgery or falsification of the content or appearance of this document is unlawful and offenders may be prosecuted to the fullest extent of the law. Unless otherwise stated the results shown in this test report refer only to the sample(s) tested and such sample(s) are retained for 30 days only.  
**Attention: To check the authenticity of testing/inspection report & certificate, please contact us at telephone: (86-755) 8307 1443, or email: CN.Doccheck@sgs.com**

South of No. 6 Plant, No. 1, Runsheng Road, Suzhou Industrial Park, Suzhou Area, China (Jiangsu) Pilot Free Trade Zone 215000  
中国·苏州·中国 (江苏) 自由贸易试验区苏州片区苏州工业园区润胜路1号的6号厂房南面 邮编: 215000

t (86-512) 62992980 www.sgs.com.cn  
t (86-512) 62992980 sgs.china@sgs.com

### REVISION HISTORY

Revision Record				
Version	Chapter	Date	Modifier	Remark
01		2024-01-25		Original



Unless otherwise agreed in writing, this document is issued by the Company subject to its General Conditions of Service printed overleaf, available on request or accessible at <http://www.sgs.com/en/Terms-and-Conditions.aspx> and, for electronic format documents, subject to Terms and Conditions for Electronic Documents at <http://www.sgs.com/en/Terms-and-Conditions/Terms-e-Documents.aspx>. Attention is drawn to the limitation of liability, indemnification and jurisdiction issues defined therein. Any holder of this document is advised that information contained hereon reflects the Company's findings at the time of its intervention only and within the limits of Client's instructions, if any. The Company's sole responsibility is to its Client and this document does not exonerate parties to a transaction from exercising all their rights and obligations under the transaction documents. This document cannot be reproduced except in full, without prior written approval of the Company. Any unauthorized alteration, forgery or falsification of the content or appearance of this document is unlawful and offenders may be prosecuted to the fullest extent of the law. Unless otherwise stated the results shown in this test report refer only to the sample(s) tested and such sample(s) are retained for 30 days only.

Attention: To check the authenticity of testing/inspection report & certificate, please contact us at telephone: (86-755) 8307 1443, or email: [CN.Doccheck@sgs.com](mailto:CN.Doccheck@sgs.com)

### TEST SUMMARY

Frequency Band	Test Results
GSM 850	PASS
PCS 1900	PASS
WCDMA band 2	PASS
WCDMA band 5	PASS
LTE band 2	PASS
LTE band 4	PASS
LTE band 5	PASS
LTE band 12	PASS
LTE band 14	PASS
LTE band 17	PASS
LTE band 26	PASS
LTE band 30	PASS
LTE band 48	PASS
LTE band 66	PASS
LTE band 71	PASS
n2	PASS
n5	PASS
n25	PASS
n26	PASS
n30	PASS
n41	PASS
n48	PASS
n66	PASS
n70	PASS
n71	PASS
n77	PASS
WLAN2.4GHz	PASS
WLAN5GHz	PASS
<b>HAC Test result: PASS</b>	

Reviewed by

Nick Hu

Prepared by

Leon Xu



Unless otherwise agreed in writing, this document is issued by the Company subject to its General Conditions of Service printed overleaf, available on request or accessible at <http://www.sgs.com/en/Terms-and-Conditions.aspx> and, for electronic format documents, subject to Terms and Conditions for Electronic Documents at <http://www.sgs.com/en/Terms-and-Conditions/Terms-e-Documents.aspx>. Attention is drawn to the limitation of liability, indemnification and jurisdiction issues defined therein. Any holder of this document is advised that information contained hereon reflects the Company's findings at the time of its intervention only and within the limits of Client's instructions, if any. The Company's sole responsibility is to its Client and this document does not exonerate parties to a transaction from exercising all their rights and obligations under the transaction documents. This document cannot be reproduced except in full, without prior written approval of the Company. Any unauthorized alteration, forgery or falsification of the content or appearance of this document is unlawful and offenders may be prosecuted to the fullest extent of the law. Unless otherwise stated the results shown in this test report refer only to the sample(s) tested and such sample(s) are retained for 30 days only.

Attention: To check the authenticity of testing / inspection report & certificate, please contact us at telephone: (86-755) 8307 1443, or email: [CN.Doccheck@sgs.com](mailto:CN.Doccheck@sgs.com)

South of No. 6 Plant, No. 1, Runsheng Road, Suzhou Industrial Park, Suzhou Area, China (Jiangsu) Pilot Free Trade Zone 215000 t (86-512) 62992980 www.sgs.com.cn  
 中国·苏州·中国(江苏)自由贸易试验区苏州片区苏州工业园区润胜路1号的6号厂房南楼 邮编: 215000 t (86-512) 62992980 sgs.china@sgs.com

## CONTENTS

<b>1</b>	<b>GENERAL INFORMATION</b>	<b>5</b>
1.1	Introduction	5
1.2	Details of Client	5
1.3	Test Location	5
1.4	Test Facility	6
1.5	General Description of EUT	7
1.5.1	DUT Antenna Locations(Back view)	9
1.5.2	List of air interfaces/frequency bands	10
1.6	Test Specification	11
1.7	ANSI C63.19-2019 limits	11
<b>2</b>	<b>CALIBRATION CERTIFICATE</b>	<b>12</b>
<b>3</b>	<b>HAC (T-COIL) MEASUREMENT SYSTEM</b>	<b>13</b>
3.1	Measurement System Diagram for SPEAG Robotic	13
3.2	T-Coil Measurement	14
3.3	System Calibration	19
3.4	Audio Magnetic Probe AM1DV3	20
3.5	Test Arch	20
3.6	Phone Holder	20
3.7	AMCC- Audio Magnetic Calibration Coil	21
3.8	AMMI - Audio Magnetic Measurement Instrument	21
<b>4</b>	<b>MEASUREMENT UNCERTAINTY EVALUATION</b>	<b>22</b>
<b>5</b>	<b>HAC (T-COIL) MEASUREMENT</b>	<b>23</b>
5.1	T-Coil Performance Requirements	23
5.2	T-Coil measurement points and reference plane	25
5.3	T-Coil Measurement Procedure	26
<b>6</b>	<b>T-COIL TESTING FOR CMRS VOICE</b>	<b>27</b>
6.1	General Description	27
6.2	GSM Tests Results	27
6.3	UMTS Tests Results	28
<b>7</b>	<b>T-COIL TESTING FOR CMRS IP VOICE</b>	<b>29</b>
7.1	VoLTE/VONR Tests Results	29
7.2	VoWiFi Tests Results	33
7.3	T-Coil testing for OTT VoIP Application	35
<b>8</b>	<b>EQUIPMENT LIST</b>	<b>37</b>
<b>9</b>	<b>CALIBRATION CERTIFICATE</b>	<b>37</b>
<b>10</b>	<b>PHOTOGRAPHS</b>	<b>37</b>
	<b>APPENDIX A: DETAILED TEST RESULTS</b>	<b>37</b>
	<b>APPENDIX B: CALIBRATION CERTIFICATE</b>	<b>37</b>
	<b>APPENDIX C: PHOTOGRAPHS</b>	<b>37</b>



Unless otherwise agreed in writing, this document is issued by the Company subject to its General Conditions of Service printed overleaf, available on request or accessible at <http://www.sgs.com/en/Terms-and-Conditions.aspx> and, for electronic format documents, subject to Terms and Conditions for Electronic Documents at <http://www.sgs.com/en/Terms-and-Conditions/Terms-e-Documents.aspx>. Attention is drawn to the limitation of liability, indemnification and jurisdiction issues defined therein. Any holder of this document is advised that information contained hereon reflects the Company's findings at the time of its intervention only and within the limits of Client's instructions, if any. The Company's sole responsibility is to its Client and this document does not exonerate parties to a transaction from exercising all their rights and obligations under the transaction documents. This document cannot be reproduced except in full, without prior written approval of the Company. Any unauthorized alteration, forgery or falsification of the content or appearance of this document is unlawful and offenders may be prosecuted to the fullest extent of the law. Unless otherwise stated the results shown in this test report refer only to the sample(s) tested and such sample(s) are retained for 30 days only.

Attention: To check the authenticity of testing/inspection report & certificate, please contact us at telephone: (86-755) 8307 1443, or email: CN.Doccheck@sgs.com

South of No. 6 Plant, No. 1, Runsheng Road, Suzhou Industrial Park, Suzhou Area, China (Jiangsu) Pilot Free Trade Zone 215000 t (86-512) 62992980 www.sgs.com.cn  
 中国·苏州·中国(江苏)自由贸易试验区苏州片区苏州工业园区润胜路1号的6号厂房南楼 邮编: 215000 t (86-512) 62992980 sgs.china@sgs.com

# 1 General Information

## 1.1 Introduction

The purpose of this standard is to provide tests and establish requirements for hearing aids and for WDs that allow a hearing aid user to effectively use a WD when both the hearing aid and WD meet the requirements of this standard. The various parameters required in order to demonstrate compatibility are measured. The design of the standard is such that when a hearing aid and a WD achieve the specified requirements, as measured by the methodology of this standard, the user of a hearing aid can effectively use a WD. In order to provide for the usability of a hearing aid with a WD, several factors are coordinated, as follows:

- a) The field strength emitted by a WD must not exceed the RF immunity of the hearing aid.
- b) The T-Coil baseband H-field transmission of the WD must be compatible with the T-Coil mode of the hearing aid.
- c) The magnetic noise from the WD in the T-Coil band must not degrade the reception quality to unacceptable levels.

Both the WD's RF and audio-band emissions are measured. Hence, the following measurements are made for the WDs:

- a) RF amplitude modulation characteristics and power level or, optionally, near-feld E-field emissions
- b) T-Coil mode, magnetic signal strength in the audio band.
- c) T-Coil mode, magnetic noise in the audio band
- d) T-Coil mode, magnetic signal frequency response in the audio band

Corresponding to these quantities, the hearing aid is measured for the following:

- 1) RF immunity in microphone mode
- 2) RF immunity in T-Coil mode

## 1.2 Details of Client

Applicant:	COOSEA GROUP (HK) COMPANY LIMITED
Address:	UNIT 5-6 16/F MULTIFIELD PLAZA 3-7A PRAT AVENUE TSIMSHATSUI KL
Manufacturer:	COOSEA GROUP (HK) COMPANY LIMITED
Address:	UNIT 5-6 16/F MULTIFIELD PLAZA 3-7A PRAT AVENUE TSIMSHATSUI KL

## 1.3 Test Location

Company:	SGS-CSTC Standards Technical Services (Suzhou) Co., Ltd.
Address:	South of No. 6 Plant, No. 1, Runsheng Road, Suzhou Industrial Park, Suzhou Area, China (Jiangsu) Pilot Free Trade Zone
Post code:	215000
Test Engineer:	Leon Liu



Unless otherwise agreed in writing, this document is issued by the Company subject to its General Conditions of Service printed overleaf, available on request or accessible at <http://www.sgs.com/en/Terms-and-Conditions.aspx> and, for electronic format documents, subject to Terms and Conditions for Electronic Documents at <http://www.sgs.com/en/Terms-and-Conditions/Terms-e-Documents.aspx>. Attention is drawn to the limitation of liability, indemnification and jurisdiction issues defined therein. Any holder of this document is advised that information contained hereon reflects the Company's findings at the time of its intervention only and within the limits of Client's instructions, if any. The Company's sole responsibility is to its Client and this document does not exonerate parties to a transaction from exercising all their rights and obligations under the transaction documents. This document cannot be reproduced except in full, without prior written approval of the Company. Any unauthorized alteration, forgery or falsification of the content or appearance of this document is unlawful and offenders may be prosecuted to the fullest extent of the law. Unless otherwise stated the results shown in this test report refer only to the sample(s) tested and such sample(s) are retained for 30 days only.

Attention: To check the authenticity of testing / inspection report & certificate, please contact us at telephone: (86-755) 8307 1443, or email: [CN.Doccheck@sgs.com](mailto:CN.Doccheck@sgs.com)

South of No. 6 Plant, No. 1, Runsheng Road, Suzhou Industrial Park, Suzhou Area, China (Jiangsu) Pilot Free Trade Zone 215000 t (86-512) 62992980 www.sgsgroup.com.cn  
 中国·苏州·中国(江苏)自由贸易试验区苏州片区苏州工业园区润胜路1号的6号厂房南楼 邮编: 215000 t (86-512) 62992980 sgs.china@sgs.com

## 1.4 Test Facility

The test facility is recognized, certified, or accredited by the following organizations:

• **A2LA (Certificate No. 6336.01)**

SGS-CSTC STANDARDS TECHNICAL SERVICES (SUZHOU) CO., LTD. is accredited by the American Association for Laboratory Accreditation(A2LA). Certificate No. 6336.01.

• **Innovation, Science and Economic Development Canada**

SGS-CSTC STANDARDS TECHNICAL SERVICES (SUZHOU) CO., LTD. has been recognized by ISED as an accredited testing laboratory.

CAB identifier: CN0120.

IC#: 27594.

• **FCC –Designation Number: CN1312**

SGS-CSTC STANDARDS TECHNICAL SERVICES (SUZHOU) CO., LTD. has been recognized as an accredited testing laboratory.



Unless otherwise agreed in writing, this document is issued by the Company subject to its General Conditions of Service printed overleaf, available on request or accessible at <http://www.sgs.com/en/Terms-and-Conditions.aspx> and, for electronic format documents, subject to Terms and Conditions for Electronic Documents at <http://www.sgs.com/en/Terms-and-Conditions/Terms-e-Documents.aspx>. Attention is drawn to the limitation of liability, indemnification and jurisdiction issues defined therein. Any holder of this document is advised that information contained hereon reflects the Company's findings at the time of its intervention only and within the limits of Client's instructions, if any. The Company's sole responsibility is to its Client and this document does not exonerate parties to a transaction from exercising all their rights and obligations under the transaction documents. This document cannot be reproduced except in full, without prior written approval of the Company. Any unauthorized alteration, forgery or falsification of the content or appearance of this document is unlawful and offenders may be prosecuted to the fullest extent of the law. Unless otherwise stated the results shown in this test report refer only to the sample(s) tested and such sample(s) are retained for 30 days only.  
**Attention: To check the authenticity of testing /inspection report & certificate, please contact us at telephone: (86-755) 8307 1443, or email: CN.Doccheck@sgs.com**

South of No. 6 Plant, No. 1, Runsheng Road, Suzhou Industrial Park, Suzhou Area, China (Jiangsu) Pilot Free Trade Zone 215000 t (86-512) 62992980 www.sgs.com.cn  
 中国·苏州·中国(江苏)自由贸易试验区苏州片区苏州工业园区润胜路1号的6号厂房南部 邮编: 215000 t (86-512) 62992980 sgs.china@sgs.com

### 1.5 General Description of EUT

Device Type :	portable device		
Exposure Category:	uncontrolled environment / general population		
Product Name:	smart phone		
Model No.(EUT):	SN339D		
FCC ID:	2A28USN339D		
Product Phase:	Identical Prototype		
IMEI:	356704760005055		
Hardware Version:	1.0		
Software Version:	SN339DD10010		
Antenna Type:	Inner Antenna		
Device Operating Configurations :			
Modulation Mode:	<b>GSM:</b> GMSK, 8PSK; <b>WCDMA:</b> QPSK; <b>LTE:</b> QPSK, 16QAM; <b>NR:</b> BPSK, QPSK, 16QAM, 64QAM, 256QAM, CP-OFDM <b>WIFI:</b> DSSS, OFDM; <b>BT:</b> GFSK, π/4DQPSK, 8DPSK		
Device Class:	B		
GPRS Multi-slots Class:	12	EGPRS Multi-slots Class:	12
HSDPA UE Category:	24	HSUPA UE Category	7
Power Class	4, tested with power level 5(GSM850)		
	1, tested with power level 0(GSM1900)		
	3, tested with power control "all 1"(WCDMA Band)		
	3, tested with power control Max Power(LTE Band)		
Frequency Bands:	Band	Tx (MHz)	Rx (MHz)
	GSM 850	824 - 849 MHz	869 - 894 MHz
	PCS 1900	1850 - 1910 MHz	1930 - 1990 MHz
	WCDMA band 2	1850 -1910 MHz	1930 - 1990 MHz
	WCDMA band 5	824 - 849MHz	869 - 894MHz
	LTE band 2	1850 - 1910 MHz	1930 - 1990 MHz
	LTE band 4	1710 - 1755 MHz	2110 - 2155 MHz
	LTE band 5	824 - 849 MHz	869 - 894 MHz
	LTE band 12	699 - 716 MHz	729 - 746 MHz
	LTE band 14	788 - 798 MHz	758 - 768 MHz
	LTE band 17	704 - 716 MHz	734 - 746 MHz
	LTE band 26	814 - 849 MHz	859 - 894 MHz
	LTE band 30	2305 - 2315 MHz	2350 - 2360 MHz
	LTE band 48	3550 - 3700 MHz	3550 - 3700 MHz
	LTE band 66	1710 - 1780 MHz	2110 - 2200 MHz
	LTE band 71	663 - 698 MHz	617 - 652 MHz
	n2	1850 - 1910 MHz	1930 - 1990 MHz
	n5	824 - 849 MHz	869 - 894 MHz
	n25	1850 - 1915 MHz	1930 - 1995 MHz
	n26	814 - 849 MHz	859 - 894 MHz
n30	2305 - 2315 MHz	2350 - 2360 MHz	



Unless otherwise agreed in writing, this document is issued by the Company subject to its General Conditions of Service printed overleaf, available on request or accessible at <http://www.sgs.com/en/Terms-and-Conditions.aspx> and, for electronic format documents, subject to Terms and Conditions for Electronic Documents at <http://www.sgs.com/en/Terms-and-Conditions/Terms-e-Documents.aspx>. Attention is drawn to the limitation of liability, indemnification and jurisdiction issues defined therein. Any holder of this document is advised that information contained hereon reflects the Company's findings at the time of its intervention only and within the limits of Client's instructions, if any. The Company's sole responsibility is to its Client and this document does not exonerate parties to a transaction from exercising all their rights and obligations under the transaction documents. This document cannot be reproduced except in full, without prior written approval of the Company. Any unauthorized alteration, forgery or falsification of the content or appearance of this document is unlawful and offenders may be prosecuted to the fullest extent of the law. Unless otherwise stated the results shown in this test report refer only to the sample(s) tested and such sample(s) are retained for 30 days only.

Attention: To check the authenticity of testing /inspection report & certificate, please contact us at telephone: (86-755) 8307 1443, or email: CN.Doccheck@sgs.com

South of No. 6 Plant, No. 1, Runsheng Road, Suzhou Industrial Park, Suzhou Area, China (Jiangsu) Pilot Free Trade Zone 215000 t (86-512) 62992980 www.sgsgroup.com.cn  
 中国·苏州·中国(江苏)自由贸易试验区苏州片区苏州工业园区润胜路1号的6号厂房南楼 邮编: 215000 t (86-512) 62992980 sgs.china@sgs.com

	n41	2496 - 2690 MHz	2496 - 2690 MHz	
	n48	3550 - 3700 MHz	3550 - 3700 MHz	
	n66	1710 - 1780 MHz	2110 - 2200 MHz	
	n70	1695 - 1710 MHz	1995 - 2020 MHz	
	n71	663 - 698 MHz	617 - 652 MHz	
	WLAN2.4GHz	2400~2483.5	2400~2483.5	
	WLAN5GHz		5150~5250MHz	5150~5250MHz
			5250~5350MHz	5250~5350MHz
			5470~5725MHz	5470~5725MHz
			5725~5850MHz	5725~5850MHz
Bluetooth	2400~2483.5	2400~2483.5		
Battery Information:	Model:	BL-A62CT		
	Normal Voltage:	+3.87V		
	Rated capacity:	4900mAh		
	Manufacturer:	Guangdong Fenghua New Energy Co.,Ltd.		

**Note:**  
 \*Since the above data and/or information is provided by the client relevant results or conclusions of this report are only made for these data and/or information, SGS is not responsible for the authenticity, integrity and results of the data and information and/or the validity of the conclusion.

**Remark:**  
 As above information is provided and confirmed by the applicant. SGS is not liable to the accuracy, suitability, reliability or/and integrity of the information.



Unless otherwise agreed in writing, this document is issued by the Company subject to its General Conditions of Service printed overleaf, available on request or accessible at <http://www.sgs.com/en/Terms-and-Conditions.aspx> and, for electronic format documents, subject to Terms and Conditions for Electronic Documents at <http://www.sgs.com/en/Terms-and-Conditions/Terms-e-Documents.aspx>. Attention is drawn to the limitation of liability, indemnification and jurisdiction issues defined therein. Any holder of this document is advised that information contained hereon reflects the Company's findings at the time of its intervention only and within the limits of Client's instructions, if any. The Company's sole responsibility is to its Client and this document does not exonerate parties to a transaction from exercising all their rights and obligations under the transaction documents. This document cannot be reproduced except in full, without prior written approval of the Company. Any unauthorized alteration, forgery or falsification of the content or appearance of this document is unlawful and offenders may be prosecuted to the fullest extent of the law. Unless otherwise stated the results shown in this test report refer only to the sample(s) tested and such sample(s) are retained for 30 days only.

**Attention: To check the authenticity of testing/inspection report & certificate, please contact us at telephone: (86-755) 8307 1443, or email: CN.Doccheck@sgs.com**

South of No. 6 Plant, No. 1, Runsheng Road, Suzhou Industrial Park, Suzhou Area, China (Jiangsu) Pilot Free Trade Zone 215000 t (86-512) 62992980 www.sgs.com.cn  
 中国·苏州·中国(江苏)自由贸易试验区苏州片区苏州工业园区润胜路1号的6号厂房南楼 邮编: 215000 t (86-512) 62992980 sgs.china@sgs.com



1.5.1 DUT Antenna Locations(Back view)

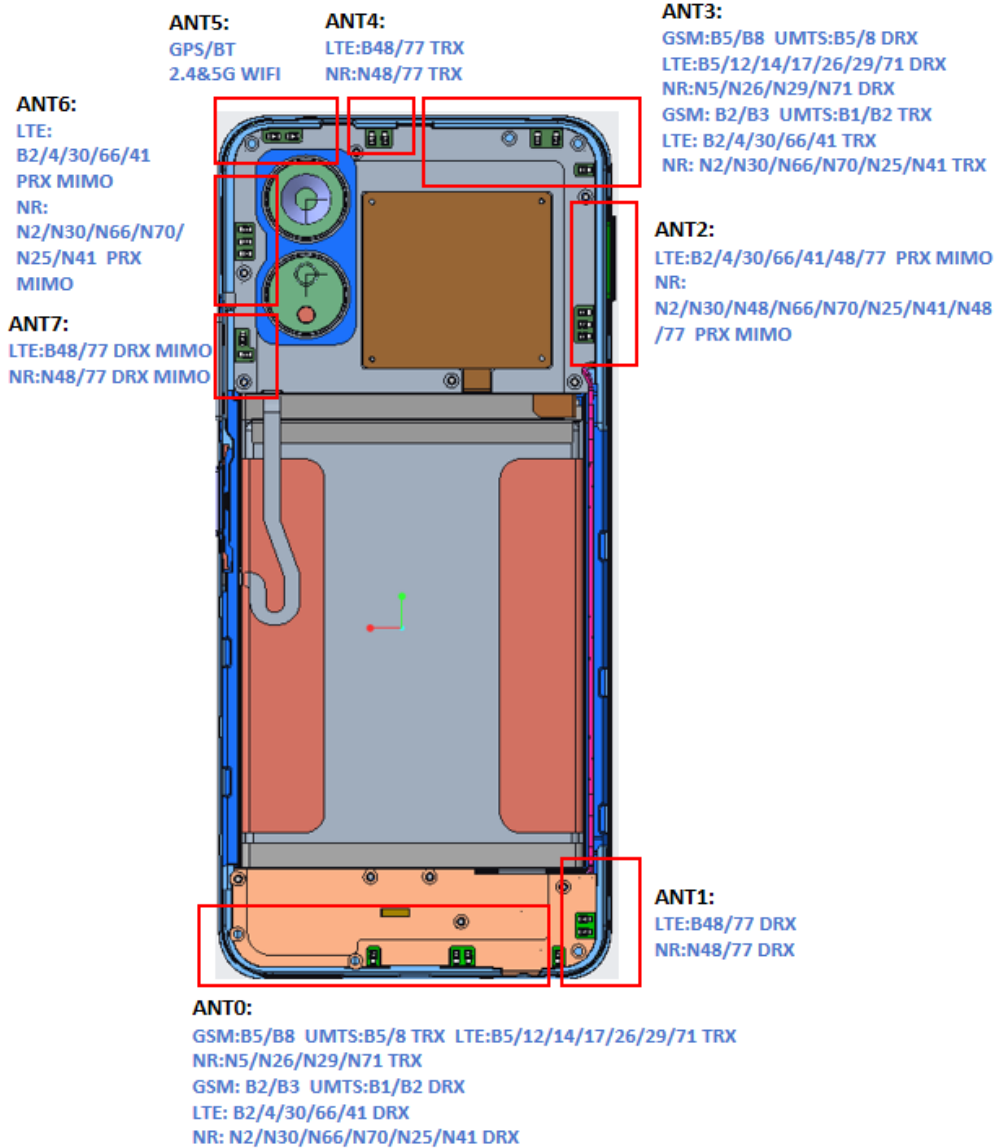

Note:

- 1) The diversity Antenna does not support transmitter function.



Unless otherwise agreed in writing, this document is issued by the Company subject to its General Conditions of Service printed overleaf, available on request or accessible at <http://www.sgs.com/en/Terms-and-Conditions.aspx> and, for electronic format documents, subject to Terms and Conditions for Electronic Documents at <http://www.sgs.com/en/Terms-and-Conditions/Terms-e-Documents.aspx>. Attention is drawn to the limitation of liability, indemnification and jurisdiction issues defined therein. Any holder of this document is advised that information contained hereon reflects the Company's findings at the time of its intervention only and within the limits of Client's instructions, if any. The Company's sole responsibility is to its Client and this document does not exonerate parties to a transaction from exercising all their rights and obligations under the transaction documents. This document cannot be reproduced except in full, without prior written approval of the Company. Any unauthorized alteration, forgery or falsification of the content or appearance of this document is unlawful and offenders may be prosecuted to the fullest extent of the law. Unless otherwise stated the results shown in this test report refer only to the sample(s) tested and such sample(s) are retained for 30 days only.

Attention: To check the authenticity of testing/inspection report & certificate, please contact us at telephone: (86-755) 8307 1443, or email: [CN.Doccheck@sgs.com](mailto:CN.Doccheck@sgs.com)

South of No. 6 Plant, No. 1, Runsheng Road, Suzhou Industrial Park, Suzhou Area, China (Jiangsu) Pilot Free Trade Zone 215000 t (86-512) 62992980 www.sgs.com.cn  
 中国·苏州·中国(江苏)自由贸易试验区苏州片区苏州工业园区润胜路1号的6号厂房南部 邮编: 215000 t (86-512) 62992980 sgs.china@sgs.com

**1.5.2 List of air interfaces/frequency bands**

Air Interface	Band (MHz)	Type	ANSI C63.19 Tested	Simultaneous Transmitter	Name of Voice Service	Power Reduction
GSM	850	VO	Yes	BT, Wi-Fi	CMRS Voice	NO
	1900				Google Duo*	
	EDGE	VD	Yes			
WCDMA	Band II	VO	Yes	BT, Wi-Fi	CMRS Voice	NO
	Band V				Google Duo*	
	HSPA	VD	Yes			
LTE (FDD)	LTE Band 2	VD	Yes	BT, Wi-Fi	VoLTE Google Duo*	NO
	LTE Band 4					
	LTE Band 5					
	LTE Band 12					
	LTE Band 14					
	LTE Band 17					
	LTE Band 26					
	LTE Band 30					
	LTE Band 48					
	LTE Band 66					
LTE Band 71						
LTE (TDD)	Band 48	VD	Yes	BT, Wi-Fi	VoLTE Google Duo*	NO
5G NR (FDD)	NR Band n2	VD	Yes	BT, Wi-Fi	VoNR Google Duo*	NO
	NR Band n5					
	NR Band n25					
	NR Band n26					
	NR Band n30					
	NR Band n66					
	NR Band n70					
NR Band n71						
5G NR (FDD)	NR Band n41	VD	Yes	BT, Wi-Fi	VoNR Google Duo*	NO
	NR Band n48					
	NR Band n77					
Wi-Fi	2450	VD	Yes	WWAN	Google Duo*	NO
BT	2450	DT	NO	WWAN	NO	NO

VO: Legacy Cellular Voice Service  
 DT: Digital Transport (no voice)  
 VD: IP Voice Service over Digital Transport  
 \* For protocols not listed in Table 6.1 of ANSI C63.19-2019, the average speech level of -16 dBm0 should be used.



Unless otherwise agreed in writing, this document is issued by the Company subject to its General Conditions of Service printed overleaf, available on request or accessible at <http://www.sgs.com/en/Terms-and-Conditions.aspx> and, for electronic format documents, subject to Terms and Conditions for Electronic Documents at <http://www.sgs.com/en/Terms-and-Conditions/Terms-e-Documents.aspx>. Attention is drawn to the limitation of liability, indemnification and jurisdiction issues defined therein. Any holder of this document is advised that information contained hereon reflects the Company's findings at the time of its intervention only and within the limits of Client's instructions, if any. The Company's sole responsibility is to its Client and this document does not exonerate parties to a transaction from exercising all their rights and obligations under the transaction documents. This document cannot be reproduced except in full, without prior written approval of the Company. Any unauthorized alteration, forgery or falsification of the content or appearance of this document is unlawful and offenders may be prosecuted to the fullest extent of the law. Unless otherwise stated the results shown in this test report refer only to the sample(s) tested and such sample(s) are retained for 30 days only.  
**Attention: To check the authenticity of testing / inspection report & certificate, please contact us at telephone: (86-755) 8307 1443, or email: CN.Doccheck@sgs.com**  
 South of No. 6 Plant, No. 1, Runsheng Road, Suzhou Industrial Park, Suzhou Area, China (Jiangsu) Pilot Free Trade Zone 215000 t (86-512) 62992980 www.sgs.com.cn  
 中国·苏州·中国(江苏)自由贸易试验区苏州片区苏州工业园区润胜路1号的6号厂房南楼 邮编: 215000 t (86-512) 62992980 sgs.china@sgs.com

### 1.6 Test Specification

Identity	Document Title
CFR 47 FCC Part 20	§20.19 Hearing aid-compatible mobile handsets.
ANSI C63.19-2019	American National Standard for Methods of Measurement of Compatibility between Wireless Communication Devices
KDB 285076 D01	HAC Guidance v06
KDB 285076 D02	T-Coil testing v04

### 1.7 ANSI C63.19-2019 limits

GSM operating modes:

- The primary group shall include at least 25 measurement points.
- The secondary group shall include at least 125 contiguous measurement points.

Non-2G GSM operating modes:

- The primary group shall include at least 75 measurement points.
- The secondary group shall include at least 300 contiguous measurement points

Additionally, to avoid an oddly shaped area of low noise, the secondary group shall

include at least one longitudinal column of at least 10 contiguous qualifying oints and t least one transverse row containing at least 15 contiguous qualifying points.



Unless otherwise agreed in writing, this document is issued by the Company subject to its General Conditions of Service printed overleaf, available on request or accessible at <http://www.sgs.com/en/Terms-and-Conditions.aspx> and, for electronic format documents, subject to Terms and Conditions for Electronic Documents at <http://www.sgs.com/en/Terms-and-Conditions/Terms-e-Documents.aspx>. Attention is drawn to the limitation of liability, indemnification and jurisdiction issues defined therein. Any holder of this document is advised that information contained hereon reflects the Company's findings at the time of its intervention only and within the limits of Client's instructions, if any. The Company's sole responsibility is to its Client and this document does not exonerate parties to a transaction from exercising all their rights and obligations under the transaction documents. This document cannot be reproduced except in full, without prior written approval of the Company. Any unauthorized alteration, forgery or falsification of the content or appearance of this document is unlawful and offenders may be prosecuted to the fullest extent of the law. Unless otherwise stated the results shown in this test report refer only to the sample(s) tested and such sample(s) are retained for 30 days only.  
**Attention: To check the authenticity of testing /inspection report & certificate, please contact us at telephone: (86-755) 8307 1443, or email: CN.Doccheck@sgs.com**

South of No. 6 Plant, No. 1, Runsheng Road, Suzhou Industrial Park, Suzhou Area, China (Jiangsu) Pilot Free Trade Zone 215000 t (86-512) 62992980 www.sgs.com.cn  
 中国·苏州·中国(江苏)自由贸易试验区苏州片区苏州工业园区润胜路1号的6号厂房南楼 邮编: 215000 t (86-512) 62992980 sgs.china@sgs.com

## 2 Calibration certificate

Temperature	Min. = 18°C, Max. = 25 °C
Relative humidity	Min. = 30%, Max. = 70%

Table 1: The Ambient Conditions



Unless otherwise agreed in writing, this document is issued by the Company subject to its General Conditions of Service printed overleaf, available on request or accessible at <http://www.sgs.com/en/Terms-and-Conditions.aspx> and, for electronic format documents, subject to Terms and Conditions for Electronic Documents at <http://www.sgs.com/en/Terms-and-Conditions/Terms-e-Documents.aspx>. Attention is drawn to the limitation of liability, indemnification and jurisdiction issues defined therein. Any holder of this document is advised that information contained hereon reflects the Company's findings at the time of its intervention only and within the limits of Client's instructions, if any. The Company's sole responsibility is to its Client and this document does not exonerate parties to a transaction from exercising all their rights and obligations under the transaction documents. This document cannot be reproduced except in full, without prior written approval of the Company. Any unauthorized alteration, forgery or falsification of the content or appearance of this document is unlawful and offenders may be prosecuted to the fullest extent of the law. Unless otherwise stated the results shown in this test report refer only to the sample(s) tested and such sample(s) are retained for 30 days only.

**Attention: To check the authenticity of testing /inspection report & certificate, please contact us at telephone: (86-755) 8307 1443, or email: CN.Doccheck@sgs.com**

South of No. 6 Plant, No. 1, Runsheng Road, Suzhou Industrial Park, Suzhou Area, China (Jiangsu) Pilot Free Trade Zone 215000 t (86-512) 62992980 www.sgs.com.cn  
 中国·苏州·中国(江苏)自由贸易试验区苏州片区苏州工业园区润胜路1号的6号厂房南面 邮编: 215000 t (86-512) 62992980 sgs.china@sgs.com

### 3 HAC (T-Coil) Measurement System

#### 3.1 Measurement System Diagram for SPEAG Robotic

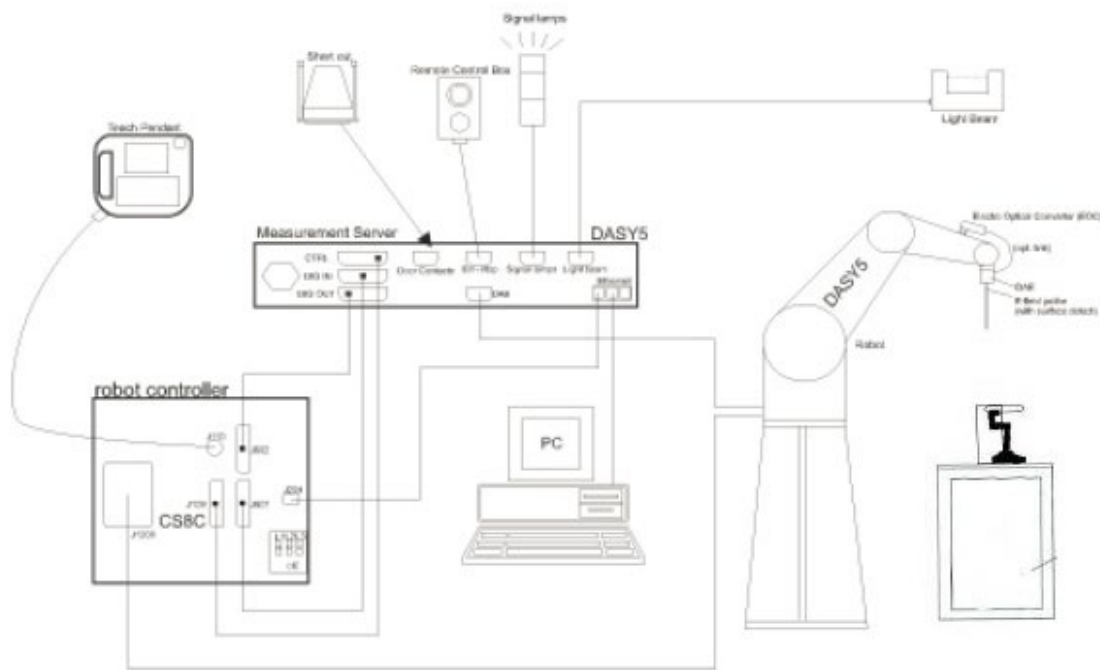

Fig. 1. The SPEAG Robotic Diagram

The DASY8 system for performing compliance tests consists of the following items:

- A standard high precision 6-axis robot (Stabile RX family) with controller, teach pendant and software. An arm extension is for accommodating the data acquisition electronics (DAE).
- An Audio Magnetic probe.
- A data acquisition electronics (DAE) which performs the signal amplification, signal multiplexing, AD-conversion, offset measurements, mechanical surface detection, collision detection, etc. The unit is battery powered with standard or rechargeable batteries. The signal is optically transmitted to the EOC.
- The Electro-optical converter (EOC) performs the conversion between optical and electrical of the signals for the digital communication to the DAE and for the analog signal from the optical surface detection. The EOC is connected to the measurement server.
- The function of the measurement server is to perform the time critical tasks such as signal filtering, control of the robot operation and fast movement interrupts.
- A probe alignment unit which improves the (absolute) accuracy of the probe positioning.
- A computer operating Windows 7.
- DASY5 software.
- Remote control with teach pendant and additional circuitry for robot safety such as warning lamps, etc.
- The Test Arch SAM phantom
- The device holder for handheld mobile phones.
- Validation dipole kits allowing to validate the proper functioning of the system.



Unless otherwise agreed in writing, this document is issued by the Company subject to its General Conditions of Service printed overleaf, available on request or accessible at <http://www.sgs.com/en/Terms-and-Conditions.aspx> and, for electronic format documents, subject to Terms and Conditions for Electronic Documents at <http://www.sgs.com/en/Terms-and-Conditions/Terms-e-Documents.aspx>. Attention is drawn to the limitation of liability, indemnification and jurisdiction issues defined therein. Any holder of this document is advised that information contained hereon reflects the Company's findings at the time of its intervention only and within the limits of Client's instructions, if any. The Company's sole responsibility is to its Client and this document does not exonerate parties to a transaction from exercising all their rights and obligations under the transaction documents. This document cannot be reproduced except in full, without prior written approval of the Company. Any unauthorized alteration, forgery or falsification of the content or appearance of this document is unlawful and offenders may be prosecuted to the fullest extent of the law. Unless otherwise stated the results shown in this test report refer only to the sample(s) tested and such sample(s) are retained for 30 days only.

Attention: To check the authenticity of testing/inspection report & certificate, please contact us at telephone: (86-755) 8307 1443, or email: CN.Doccheck@sgs.com

South of No. 6 Plant, No. 1, Runsheng Road, Suzhou Industrial Park, Suzhou Area, China (Jiangsu) Pilot Free Trade Zone 215000  
 中国·苏州·中国(江苏)自由贸易试验区苏州片区苏州工业园区润胜路1号的6号厂房南楼 邮编: 215000

t (86-512) 62992980 www.sgs.com.cn  
 t (86-512) 62992980 sgs.china@sgs.com

### 3.2 T-Coil Measurement

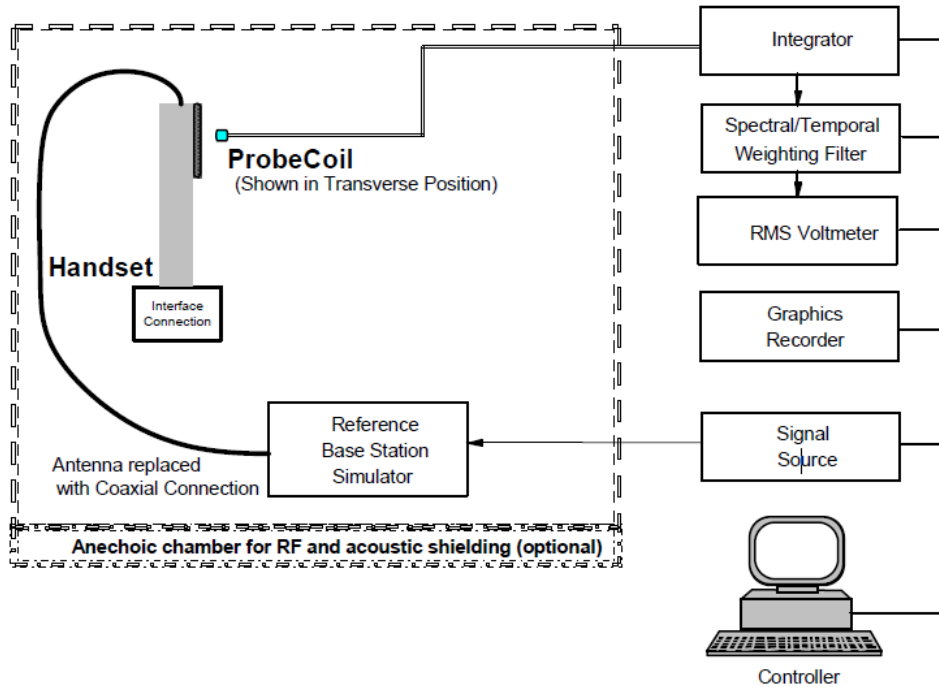

Fig. 2. T-coil signal measurement test setup-in call method

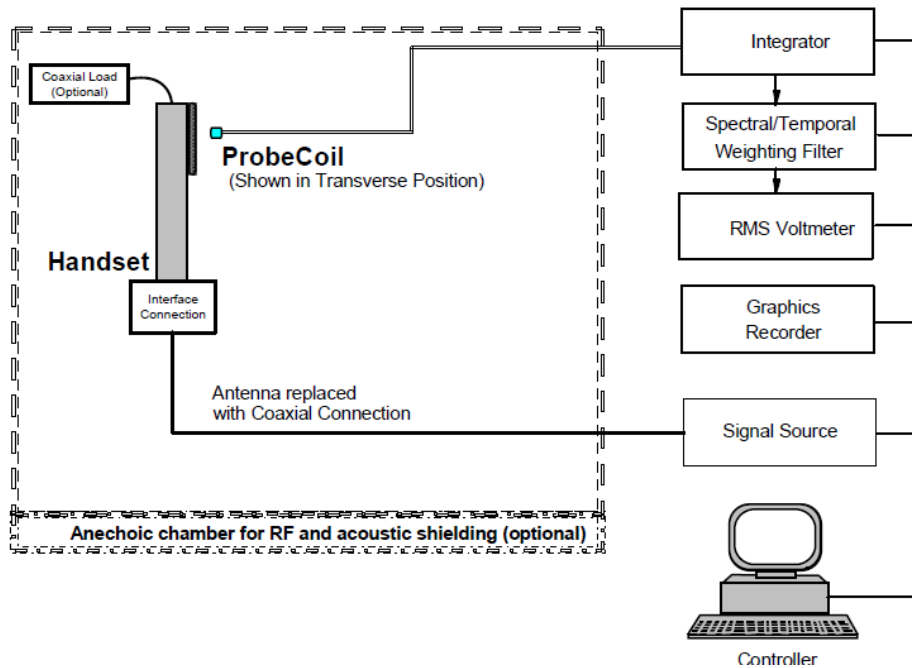

Fig. 3. T-coil signal measurement test setup-test mode method.



Unless otherwise agreed in writing, this document is issued by the Company subject to its General Conditions of Service printed overleaf, available on request or accessible at <http://www.sgs.com/en/Terms-and-Conditions.aspx> and, for electronic format documents, subject to Terms and Conditions for Electronic Documents at <http://www.sgs.com/en/Terms-and-Conditions/Terms-e-Documents.aspx>. Attention is drawn to the limitation of liability, indemnification and jurisdiction issues defined therein. Any holder of this document is advised that information contained hereon reflects the Company's findings at the time of its intervention only and within the limits of Client's instructions, if any. The Company's sole responsibility is to its Client and this document does not exonerate parties to a transaction from exercising all their rights and obligations under the transaction documents. This document cannot be reproduced except in full, without prior written approval of the Company. Any unauthorized alteration, forgery or falsification of the content or appearance of this document is unlawful and offenders may be prosecuted to the fullest extent of the law. Unless otherwise stated the results shown in this test report refer only to the sample(s) tested and such sample(s) are retained for 30 days only.

Attention: To check the authenticity of testing/inspection report & certificate, please contact us at telephone: (86-755) 8307 1443, or email: [CN.Doccheck@sgs.com](mailto:CN.Doccheck@sgs.com)

The reference axis is normal to the reference plane and passes through the center of the acoustic output (or the center of the hole array); or may be centered on or near a secondary inductive source. The actual location of the reference axis and resultant measurement area shall be noted in the test report.

The measurement area shall be 50 mm by 50 mm. The measurement area for both desired ABM signal and undesired ABM field may be located where the transverse magnetic measurements are optimum with regard to the requirements. However, the measurement area should be in the vicinity of the acoustic output of the WD and shall be located in the same half of the phone as the WD receiver. In a WD handset with a centered receiver and a circularly symmetrical magnetic field, the measurement axis and the reference axis would coincide.

Measurements of desired ABM signal strength and undesired ABM field are made at 2.0 mm +0.5 mm or 4 mm intervals in an X-Y measurement area pattern over the entire measurement area (676 measurement points total); either all measured, or measured plus interpolated.

**Note.**

#. The EUT do not use the special HAC SW.

#. Setting the maximum volume for EUT during the measurement.

#. For the measurement, it don't use the "post-test measurement processing of results".

#. Per KDB 285076 D01v06, handsets that that have the ability to support concurrent connections using simultaneous transmissions shall be independently tested for each air interface/band given in ANSI C63.19-2019. At the present time ANSI C63.19 does not provide simultaneous transmission test procedures.

# Define the all applicable input audio level as below according to c63 and KDB 285076 D02v04:

GSM input Level: -16dB

UMTS input Level: -16dB

VOLTE input Level: -16dB

VOWIFI input Level: -16dB

VONR input Level: -16dB

OTT input Level: -16dB

# For GSM/UMTS/VoLTE/VOWIF test setup and input level, the correct input level definition is via a communication tester CMW500 "Decoder Cal" and "Codec Cal" to set the correct audio input levels.

# For VONR test setup and input level, the correct input level definition is via a communication tester CMX500 and External DAU USB sound card "Decoder Cal" and "Codec Cal" to set the correct audio input levels.

# CMW500 and External DAU USB sound card is able to output 1 kHz audio signal equivalent to 3.14dBm0 at "Decoder Cal". configuration, the signal reference is used to adjust the AMMI gain setting to reach-16Bm0 for GSM/UMTS/VoLTE/VONR. CMW500/CMX500 input is calibrated and the relation between the analog input voltage and the internal level in dBm0 can be determined.



Unless otherwise agreed in writing, this document is issued by the Company subject to its General Conditions of Service printed overleaf, available on request or accessible at <http://www.sgs.com/en/Terms-and-Conditions.aspx> and, for electronic format documents, subject to Terms and Conditions for Electronic Documents at <http://www.sgs.com/en/Terms-and-Conditions/Terms-e-Documents.aspx>. Attention is drawn to the limitation of liability, indemnification and jurisdiction issues defined therein. Any holder of this document is advised that information contained hereon reflects the Company's findings at the time of its intervention only and within the limits of Client's instructions, if any. The Company's sole responsibility is to its Client and this document does not exonerate parties to a transaction from exercising all their rights and obligations under the transaction documents. This document cannot be reproduced except in full, without prior written approval of the Company. Any unauthorized alteration, forgery or falsification of the content or appearance of this document is unlawful and offenders may be prosecuted to the fullest extent of the law. Unless otherwise stated the results shown in this test report refer only to the sample(s) tested and such sample(s) are retained for 30 days only.  
**Attention: To check the authenticity of testing /inspection report & certificate, please contact us at telephone: (86-755) 8307 1443, or email: CN.Doccheck@sgs.com**

South of No. 6 Plant, No. 1, Runsheng Road, Suzhou Industrial Park, Suzhou Area, China (Jiangsu) Pilot Free Trade Zone 215000  
 中国·苏州·中国(江苏)自由贸易试验区苏州片区苏州工业园区润胜路1号的6号厂房南面 邮编: 215000

t (86-512) 62992980 www.sgs.com.cn  
 t (86-512) 62992980 sgs.china@sgs.com

### 3.2.1 Define the input level for GSM/UMTS/LTE/WLAN/NR

1. The Required gain factor for the specific signal shall typically be multiplied by this factor to achieve approx.the same level as for the 1kHz sine signal
2. The below calculation formula is an example and showing how to determine the input level for the device

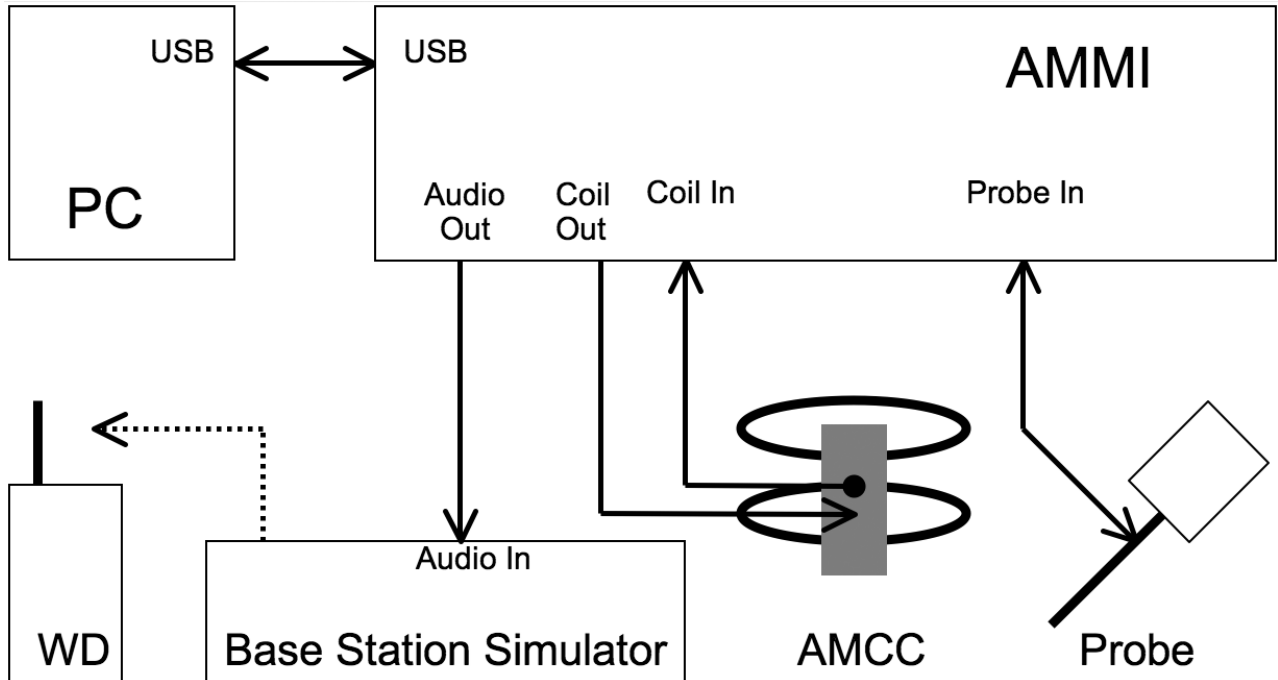

Fig. 2. T-coil signal measurement test setup

The predefined signal types have the following differences / factors compared to the 1kHz sine signal:

Signal [file name]	Duration [s]	Peak-to-RMS [dB]	RMS [dB]	Required gain factor *)	Gain setting
1kHz sine	---	3.0	0.0	1.00	
48k_1.025kHz_10s.wav	10	3.0	0.0	1.00	
48k_1kHz_3.15kHz_10s.wav	10	6.0	-3.0	1.42	
48k_315Hz_1kHz_10s.wav	10	6.0	-2.9	1.40	
48k_csek_8k_441_white_10s.wav	10	13.8	-10.5	3.34	
48k_multisine_50-5000_10s.wav	10	11.1	-7.9	2.49	
48k_voice_1kHz_1s.wav	1	16.2	-12.7	4.33	
48k_voice_300-3000_2s.wav	2	21.6	-18.6	8.48	

(\*) The gain for the specific signal shall typically be multiplied by this factor to acheive approx. the same level as for the 1kHz sine signal.

Insert the gain applicable for your setup in the last column of the table.



Unless otherwise agreed in writing, this document is issued by the Company subject to its General Conditions of Service printed overleaf, available on request or accessible at <http://www.sgs.com/en/Terms-and-Conditions.aspx> and, for electronic format documents, subject to Terms and Conditions for Electronic Documents at <http://www.sgs.com/en/Terms-and-Conditions/Document.aspx>. Attention is drawn to the limitation of liability, indemnification and jurisdiction issues defined therein. Any holder of this document is advised that information contained hereon reflects the Company's findings at the time of its intervention only and within the limits of Client's instructions, if any. The Company's sole responsibility is to its Client and this document does not exonerate parties to a transaction from exercising all their rights and obligations under the transaction documents. This document cannot be reproduced except in full, without prior written approval of the Company. Any unauthorized alteration, forgery or falsification of the content or appearance of this document is unlawful and offenders may be prosecuted to the fullest extent of the law. Unless otherwise stated the results shown in this test report refer only to the sample(s) tested and such sample(s) are retained for 30 days only.

Attention: To check the authenticity of testing /inspection report & certificate, please contact us at telephone: (86-755) 83071443, or email: CN.Doccheck@sgs.com  
 South of No. 6 Plant, No. 1, Runsheng Road, Suzhou Industrial Park, Suzhou Area, China (Jiangsu) Pilot Free Trade Zone 215000 t (86-512) 62992980 www.sgs.com.cn  
 中国·苏州·中国 (江苏) 自由贸易试验区苏州片区苏州工业园区润胜路1号的6号厂房南楼 邮编: 215000 t (86-512) 62992980 sgs.china@sgs.com



**Input Level for GSM/UMTS/VoLTE/VOWIFI/VONR**

Gain Value	dBm0	Full scal Voltage	dB	AMMI audio out dBv (RMS)	AMCC Coil Out (dBv (RMS))
	3.14	1.5		0.55	
100	5.53		40	2.94	3.09
8.39	-16		18.47		-18.44
Signal Type	Duration (s)	Peak to RMS (dB)	RMS (dB)	Gain Factor	Gain Setting
1kHz sine	-	3	0	1	8.39
48k_voice_1kHz	1	15.74	-12.7	4.33	36.32
48k_voice_300-3000	2	21.57	-18.6	8.48	71.13

**Define the input level for OTT**

1. The Required gain factor for the specific signal shall typically be multiplied by this factor to achieve approx.the same level as for the 1kHz sine signal
2. The below calculation formula is an example and showing how to determine the input level for the device.

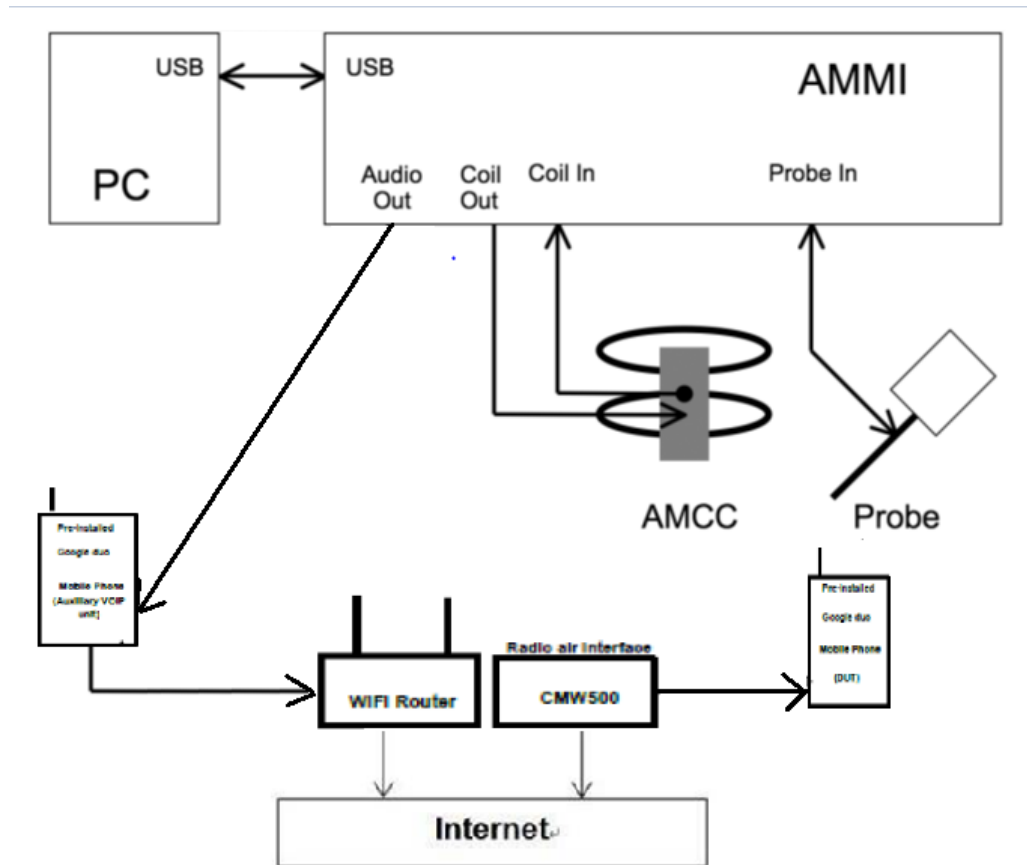

Fig. 2. T-coil signal measurement test setup



Unless otherwise agreed in writing, this document is issued by the Company subject to its General Conditions of Service printed overleaf, available on request or accessible at <http://www.sgs.com/en/Terms-and-Conditions.aspx> and, for electronic format documents, subject to Terms and Conditions for Electronic Documents at <http://www.sgs.com/en/Terms-and-Conditions/Terms-e-Documents.aspx>. Attention is drawn to the limitation of liability, indemnification and jurisdiction issues defined therein. Any holder of this document is advised that information contained hereon reflects the Company's findings at the time of its intervention only and within the limits of Client's instructions, if any. The Company's sole responsibility is to its Client and this document does not exonerate parties to a transaction from exercising all their rights and obligations under the transaction documents. This document cannot be reproduced except in full, without prior written approval of the Company. Any unauthorized alteration, forgery or falsification of the content or appearance of this document is unlawful and offenders may be prosecuted to the fullest extent of the law. Unless otherwise stated the results shown in this test report refer only to the sample(s) tested and such sample(s) are retained for 30 days only.

Attention: To check the authenticity of testing/inspection report & certificate, please contact us at telephone: (86-755) 8307 1443, or email: CN.Doccheck@sgs.com

South of No. 6 Plant, No. 1, Runsheng Road, Suzhou Industrial Park, Suzhou Area, China (Jiangsu) Pilot Free Trade Zone 215000 t (86-512) 62992980 www.sgs.com.cn  
 中国·苏州·中国(江苏)自由贸易试验区苏州片区苏州工业园区润胜路1号的6号厂房南楼 邮编: 215000 t (86-512) 62992980 sgs.china@sgs.com

- #. Voice over Internet Protocol (VoIP) such as google duo application, also called IP telephony, is a methodology and group of technologies for the delivery of voice communications and multimedia sessions over Internet Protocol (IP) networks, such as the Internet. The terms Internet telephony, broadband telephony, and broadband phone service specifically refer to the provisioning of communications services (voice, fax, SMS, voice-messaging) over the public Internet, rather than via the public switched telephone network (PSTN)
- #. The Google DUO service support code and bitrate are list in section9, the customized Google DUO software is installed on a mobile phone which is used as the Auxiliary for the test. The software enables audio coding rate to be changed, and reports the input digital audio level before audio processing which can be used to calibrate the input audio level
- #. This device comes with the preinstalled VoIP application that supports the Google DUO service and related codec. The test configuration establishes a call between the device under test and an auxiliary handset via the google DUO server
- #. The test setup used for Google DUO VoIP call is via the data application unit on the 2G/3G/4G/5G/WiFi simulate base station, connected to the internet via the google DUO server to the auxiliary device. The auxiliary device runs special software that allows the codecs and bit rate to be fixed to a specific value. Please refer to section9, an assessment was made of each of the different codec bit rates to determine the worst case for each of the different OTT transport (WiFi, LTE, GSM, WCDMA,NR)
- #. The auxiliary device includes software that displays the audio level in dBFS which allows calibration of the system to establish the -16dBm0 reference level. After establishing the voice call between auxiliary device and device under test the audio output from the AMMI is injected into the auxiliary device. The gain factor to establish a reference level of -16dBm0 for use during the test is determined as detailed in the next page based on the 0dBFull Scale (0dBFS) value being equivalent to 3.14dBm0.

**Input Level for OTT**

Gain Value	20* log(gain)	AMCC Coil Out			Level
(linear)	dB	(dBv RMS)			dBm0
		0.533			3.14
10	20	-18.39			-15.78
9.75	19.78	-22.61			-16

Signal Type	Duration (s)	Peak to RMS (dB)	RMS (dB)	Gain Factor	Gain Setting
1kHz sine	-	3	0	1	9.75
48k_voice_1kHz	1	15.74	-12.7	4.33	42.23
48k_voice_300-3000	2	21.57	-18.6	8.48	82.71



Unless otherwise agreed in writing, this document is issued by the Company subject to its General Conditions of Service printed overleaf, available on request or accessible at <http://www.sgs.com/en/Terms-and-Conditions.aspx> and, for electronic format documents, subject to Terms and Conditions for Electronic Documents at <http://www.sgs.com/en/Terms-and-Conditions/Terms-e-Documents.aspx>. Attention is drawn to the limitation of liability, indemnification and jurisdiction issues defined therein. Any holder of this document is advised that information contained hereon reflects the Company's findings at the time of its intervention only and within the limits of Client's instructions, if any. The Company's sole responsibility is to its Client and this document does not exonerate parties to a transaction from exercising all their rights and obligations under the transaction documents. This document cannot be reproduced except in full, without prior written approval of the Company. Any unauthorized alteration, forgery or falsification of the content or appearance of this document is unlawful and offenders may be prosecuted to the fullest extent of the law. Unless otherwise stated the results shown in this test report refer only to the sample(s) tested and such sample(s) are retained for 30 days only.

Attention: To check the authenticity of testing /inspection report & certificate, please contact us at telephone: (86-755) 8307 1443, or email: CN.Doccheck@sgs.com

South of No. 6 Plant, No. 1, Runsheng Road, Suzhou Industrial Park, Suzhou Area, China (Jiangsu) Pilot Free Trade Zone 215000 t (86-512) 62992980 www.sgs.com.cn  
 中国·苏州·中国(江苏)自由贸易试验区苏州片区苏州工业园区润胜路1号的6号厂房南楼 邮编: 215000 t (86-512) 62992980 sgs.china@sgs.com

### 3.3 System Calibration

For correct and calibrated measurement of the voltages and ABM field, DASYS will perform a calibration job as below.

In phase 1, the audio output is switched off, and a 200 mVpp symmetric rectangular signal of 1 kHz is generated and internally connected directly to both channels of the sampling unit (Coil in, Probe in).

In phase 2, the audio output is off, and a 20 mVpp symmetric 100 Hz signal is internally connected. The signals during phases 1 and 2 are available at the output on the rear panel of the AMMI. However, the output must not be loaded, in order to avoid influencing the calibration. An RMS voltmeter would indicate 100 mVRMS during the first phase and 10 mVRMS during the second phase. After the first two phases, the two input channels are both calibrated for absolute measurements of voltages. The resulting factors are displayed above the multi-meter window.

After phases 1 and 2, the input channels are calibrated to measure exact voltages. This is required to use the inputs for measuring voltages with their peak and RMS value.

In phase 3, a multi-sine signal covering each third-octave band from 50 Hz to 10 kHz is generated and applied to both audio outputs. The probe should be positioned in the center of the AMCC and aligned in the z-direction, the field orientation of the AMCC. The "Coil In" channel is measuring the voltage over the AMCC internal shunt, which is proportional to the magnetic field in the AMCC. At the same time, the "Probe In" channel samples the amplified signal picked up by the probe coil and provides it to a numerical integrator. The ratio of the two voltages in each third-octave filter leads to the spectral representation over the frequency band of interest. The Coil signal is scaled in dBV, and the Probe signal is first integrated and normalized to show dB A/m. The ratio probe-to-coil at the frequency of 1 kHz is the sensitivity which will be used in the consecutive T-Coil jobs.



Unless otherwise agreed in writing, this document is issued by the Company subject to its General Conditions of Service printed overleaf, available on request or accessible at <http://www.sgs.com/en/Terms-and-Conditions.aspx> and, for electronic format documents, subject to Terms and Conditions for Electronic Documents at <http://www.sgs.com/en/Terms-and-Conditions/Terms-e-Documents.aspx>. Attention is drawn to the limitation of liability, indemnification and jurisdiction issues defined therein. Any holder of this document is advised that information contained hereon reflects the Company's findings at the time of its intervention only and within the limits of Client's instructions, if any. The Company's sole responsibility is to its Client and this document does not exonerate parties to a transaction from exercising all their rights and obligations under the transaction documents. This document cannot be reproduced except in full, without prior written approval of the Company. Any unauthorized alteration, forgery or falsification of the content or appearance of this document is unlawful and offenders may be prosecuted to the fullest extent of the law. Unless otherwise stated the results shown in this test report refer only to the sample(s) tested and such sample(s) are retained for 30 days only.  
**Attention: To check the authenticity of testing/inspection report & certificate, please contact us at telephone: (86-755) 8307 1443, or email: CN.Doccheck@sgs.com**

### 3.4 Audio Magnetic Probe AM1DV3

Description	Active single sensor probe for both axial and radial measurement scans- Fully RF shielded, compatible with DAE, with adapted probe cup	 <p>AM1DV3 Audio Probe</p>
Dynamic Range	0.1 KHz to 20 KHz	
Sensitivity	<-50dB A/m @ 1KHz	
Internal Amp	20dB	
Dimensions	300X18mm	

### 3.5 Test Arch

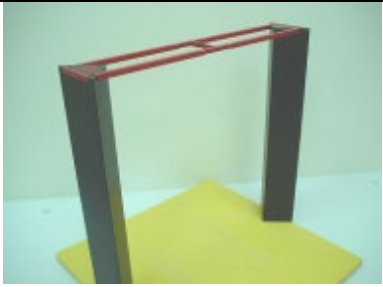
Description	Enables easy and well defined positioning of the phone and validation dipoles as well as simple teaching of the robot.	 <p>Test Arch</p>
Dimensions	length: 370 mm width: 370 mm height: 370 mm	

### 3.6 Phone Holder

Description	Supports accurate and reliable positioning of any phone Effect on near field <+/- 0.5 dB	 <p>Phone Holder</p>
-------------	--	---



Unless otherwise agreed in writing, this document is issued by the Company subject to its General Conditions of Service printed overleaf, available on request or accessible at <http://www.sgs.com/en/Terms-and-Conditions.aspx> and, for electronic format documents, subject to Terms and Conditions for Electronic Documents at <http://www.sgs.com/en/Terms-and-Conditions/Terms-e-Documents.aspx>. Attention is drawn to the limitation of liability, indemnification and jurisdiction issues defined therein. Any holder of this document is advised that information contained hereon reflects the Company's findings at the time of its intervention only and within the limits of Client's instructions, if any. The Company's sole responsibility is to its Client and this document does not exonerate parties to a transaction from exercising all their rights and obligations under the transaction documents. This document cannot be reproduced except in full, without prior written approval of the Company. Any unauthorized alteration, forgery or falsification of the content or appearance of this document is unlawful and offenders may be prosecuted to the fullest extent of the law. Unless otherwise stated the results shown in this test report refer only to the sample(s) tested and such sample(s) are retained for 30 days only.

Attention: To check the authenticity of testing /inspection report & certificate, please contact us at telephone: (86-755) 8307 1443, or email: [CN.Doccheck@sgs.com](mailto:CN.Doccheck@sgs.com)

South of No. 6 Plant, No. 1, Runsheng Road, Suzhou Industrial Park, Suzhou Area, China (Jiangsu) Pilot Free Trade Zone 215000 t (86-512) 62992980 www.sgs.com.cn  
 中国·苏州·中国(江苏)自由贸易试验区苏州片区苏州工业园区润胜路1号的6号厂房南楼 邮编: 215000 t (86-512) 62992980 sgs.china@sgs.com

### 3.7 AMCC- Audio Magnetic Calibration Coil

<p>Description</p>	<p>Allows calibration of the complete measurement setup, the two horizontal coils create a homogeneous magnetic field in the z direction. Refer to Appendix 5 for more detail on AMCC coil</p>	 <p>AMCC</p>
--------------------	--	---

### 3.8 AMMI - Audio Magnetic Measurement Instrument

<p>Description</p>	<p>-USB interface to PC - Probe signal digitization and power supply- Test signal generation for wireless device (via base station simulator)- Auto-calibration and interfaces to AMCC for complete setup-calibration</p>	 <p>AMMI</p>
<p>Data Rate</p>	<p>48 KHz / 24bit</p>	
<p>Dynamic Range</p>	<p>85 dB</p>	
<p>Dimensions:</p>	<p>19" X 65 X 270mm</p>	



Unless otherwise agreed in writing, this document is issued by the Company subject to its General Conditions of Service printed overleaf, available on request or accessible at <http://www.sgs.com/en/Terms-and-Conditions.aspx> and, for electronic format documents, subject to Terms and Conditions for Electronic Documents at <http://www.sgs.com/en/Terms-and-Conditions/Terms-e-Documents.aspx>. Attention is drawn to the limitation of liability, indemnification and jurisdiction issues defined therein. Any holder of this document is advised that information contained hereon reflects the Company's findings at the time of its intervention only and within the limits of Client's instructions, if any. The Company's sole responsibility is to its Client and this document does not exonerate parties to a transaction from exercising all their rights and obligations under the transaction documents. This document cannot be reproduced except in full, without prior written approval of the Company. Any unauthorized alteration, forgery or falsification of the content or appearance of this document is unlawful and offenders may be prosecuted to the fullest extent of the law. Unless otherwise stated the results shown in this test report refer only to the sample(s) tested and such sample(s) are retained for 30 days only.

Attention: To check the authenticity of testing/inspection report & certificate, please contact us at telephone: (86-755) 8307 1443, or email: [CN.Doccheck@sgs.com](mailto:CN.Doccheck@sgs.com)

South of No. 6 Plant, No. 1, Runsheng Road, Suzhou Industrial Park, Suzhou Area, China (Jiangsu) Pilot Free Trade Zone 215000 t (86-512) 62992980 www.sgs.com.cn  
 中国·苏州·中国(江苏)自由贸易试验区苏州片区苏州工业园区润胜路1号的6号厂房南楼 邮编: 215000 t (86-512) 62992980 sgs.china@sgs.com

### 4 Measurement uncertainty evaluation

Error Description	Uncertainty Value (%)	Probability Dist.	Divisor	ci ABM1	ci ABM2	Standard Uncertainty ABM1 (%)	Standard Uncertainty ABM2 (%)
<b>Related to probe sensitivity</b>							
Reference level	±3.0	R	$\sqrt{3}$	1	1	±3.0	±3.0
AMCC geometry	±0.4	R	$\sqrt{3}$	1	1	±0.2	±0.2
AMCC current	±0.6	R	$\sqrt{3}$	1	1	±0.4	±0.4
Probe positioning during calibration	±0.2	R	$\sqrt{3}$	1	1	±0.1	±0.1
Noise distribution	±0.7	R	$\sqrt{3}$	0.0143	1	±0.0	±0.4
Frequency slope	±5.9	R	$\sqrt{3}$	0.1	1	±0.3	±3.5
<b>Related to probe system</b>							
Repeatability / drift	±1.0	R	$\sqrt{3}$	1	1	±0.6	±0.6
Linearity / dynamic range	±0.6	N	1	1	1	±0.4	±0.4
Audio noise	±1.0	R	$\sqrt{3}$	0.1	1	±0.1	±0.6
Probe angle	±2.3	R	$\sqrt{3}$	1	1	±1.4	±1.4
Spectral Processing	±0.9	R	$\sqrt{3}$	1	1	±0.5	±0.5
Integration time	±0.6	N	1	1	5	±0.6	±3.0
Field distribution	±0.2	R	$\sqrt{3}$	1	1	±0.1	±0.1
<b>Test signal</b>							
Reference signal spectrum response	±0.6	R	$\sqrt{3}$	0	1	±0.0	±0.4
<b>Positioning</b>							
Probe positioning	±1.9	R	$\sqrt{3}$	1	1	±1.1	±1.1
Phantom Thickness	±0.9	R	$\sqrt{3}$	1	1	±0.5	±0.5
DUT positioning	±1.9	R	$\sqrt{3}$	1	1	±1.1	±1.1
<b>External Contributions</b>							
RF interference	±0.0	R	$\sqrt{3}$	1	0.3	±0.0	±0.0
Test Signal Variation	±2.0	R	$\sqrt{3}$	1	1	±1.2	±1.2
Combined Std. Uncertainty (ABM Field)	$u'_c = \sqrt{\sum_{i=1}^{20} c_i^2 u_i^2}$					±4.1	±6.2
Expanded Std. Uncertainty (K=2)						±8.2	±12.4

Table 2: Measurement uncertainties for T-Coil



Unless otherwise agreed in writing, this document is issued by the Company subject to its General Conditions of Service printed overleaf, available on request or accessible at <http://www.sgs.com/en/Terms-and-Conditions.aspx> and, for electronic format documents, subject to Terms and Conditions for Electronic Documents at <http://www.sgs.com/en/Terms-and-Conditions/Terms-e-Documents.aspx>. Attention is drawn to the limitation of liability, indemnification and jurisdiction issues defined therein. Any holder of this document is advised that information contained hereon reflects the Company's findings at the time of its intervention only and within the limits of Client's instructions, if any. The Company's sole responsibility is to its Client and this document does not exonerate parties to a transaction from exercising all their rights and obligations under the transaction documents. This document cannot be reproduced except in full, without prior written approval of the Company. Any unauthorized alteration, forgery or falsification of the content or appearance of this document is unlawful and offenders may be prosecuted to the fullest extent of the law. Unless otherwise stated the results shown in this test report refer only to the sample(s) tested and such sample(s) are retained for 30 days only.

Attention: To check the authenticity of testing/inspection report & certificate, please contact us at telephone: (86-755) 8307 1443, or email: [CN.Doccheck@sgs.com](mailto:CN.Doccheck@sgs.com)

South of No. 6 Plant, No. 1, Runsheng Road, Suzhou Industrial Park, Suzhou Area, China (Jiangsu) Pilot Free Trade Zone 215000 t (86-512) 62992980 www.sgs.com.cn  
 中国·苏州·中国(江苏)自由贸易试验区苏州片区苏州工业园区润胜路1号的6号厂房南楼 邮编: 215000 t (86-512) 62992980 sgs.china@sgs.com

## 5 HAC (T-Coil) Measurement

### 5.1 T-Coil Performance Requirements

In order to be rated for T-Coil use, a WD shall meet the requirements for signal level and signal quality contained in this part.

#### 1) T-Coil coupling field intensity

When measured as specified in ANSI C63.19, the T-Coil signal shall be  $\geq -18$  dB (A/m) at 1 kHz, in a 1/3 octave band filter for all orientations.

#### 2) Frequency response

The frequency response of the axial component of the magnetic field, measured in 1/3 octave bands, shall follow the response curve specified in this sub-clause, over the frequency range 300 Hz to 3000 Hz. Figure 1 and Figure 2 provide the boundaries for the specified frequency.

These response curves are for true field strength measurements of the T-Coil signal. Thus the 6 dB/octave probe response has been corrected from the raw readings.

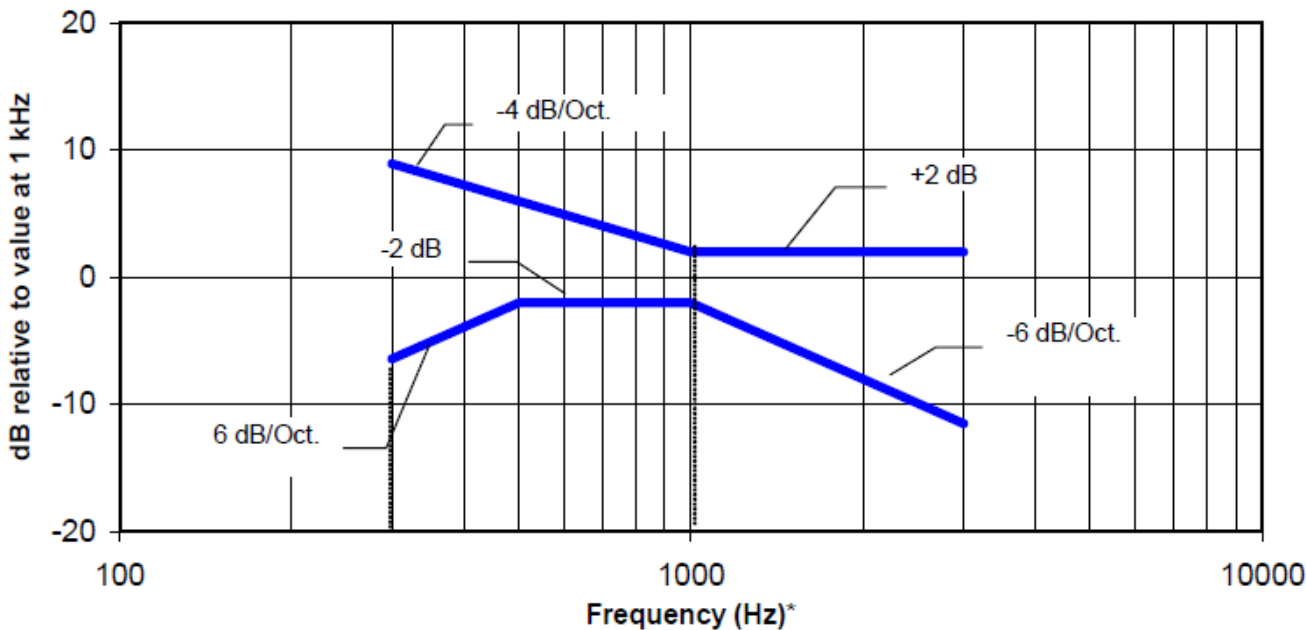

Figure 1—Magnetic field frequency response for WDs with a field  $\leq -15$  dB (A/m) at 1 kHz



Unless otherwise agreed in writing, this document is issued by the Company subject to its General Conditions of Service printed overleaf, available on request or accessible at <http://www.sgs.com/en/Terms-and-Conditions.aspx> and, for electronic format documents, subject to Terms and Conditions for Electronic Documents at <http://www.sgs.com/en/Terms-and-Conditions/Terms-e-Documents.aspx>. Attention is drawn to the limitation of liability, indemnification and jurisdiction issues defined therein. Any holder of this document is advised that information contained hereon reflects the Company's findings at the time of its intervention only and within the limits of Client's instructions, if any. The Company's sole responsibility is to its Client and this document does not exonerate parties to a transaction from exercising all their rights and obligations under the transaction documents. This document cannot be reproduced except in full, without prior written approval of the Company. Any unauthorized alteration, forgery or falsification of the content or appearance of this document is unlawful and offenders may be prosecuted to the fullest extent of the law. Unless otherwise stated the results shown in this test report refer only to the sample(s) tested and such sample(s) are retained for 30 days only.  
 Attention: To check the authenticity of testing / inspection report & certificate, please contact us at telephone: (86-755) 8307 1443, or email: CN.Doccheck@sgs.com

South of No. 6 Plant, No. 1, Runsheng Road, Suzhou Industrial Park, Suzhou Area, China (Jiangsu) Pilot Free Trade Zone 215000 t (86-512) 62992980 www.sgs.com.cn  
 中国·苏州·中国(江苏)自由贸易试验区苏州片区苏州工业园区润胜路1号的6号厂房南部 邮编: 215000 t (86-512) 62992980 sgs.china@sgs.com

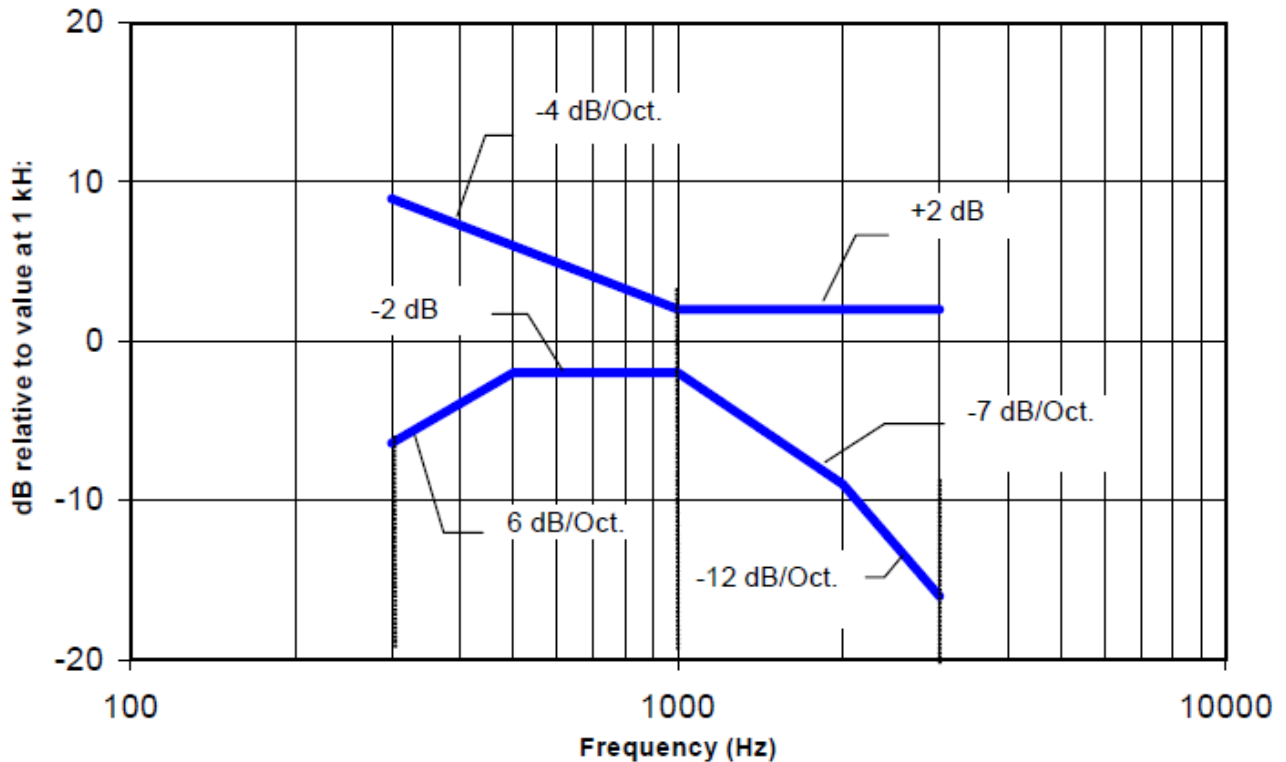

Figure 2 —Magnetic field frequency response for WDs with a field that exceeds  $-15\text{dB(A/m)}$  at 1 kHz

**3) Signal quality**

This part provides the signal quality requirement for the intended T-Coil signal from a WD. Only the RF immunity of the hearing aid is measured in T-Coil mode. It is assumed that a hearing aid can have no immunity to an interference signal in the audio band, which is the intended reception band for this mode. So, the only criteria that can be measured is the RF immunity in T-Coil mode. This is measured using the same procedure as for the audio coupling mode and at the same levels.

The worst signal quality of the three T-Coil signal measurements shall be used to determine the T-Coil mode category per Table 3

Category	Telephone parameters WD signal quality [(signal + noise) – to – noise ratio in decibels]
Category T1	0 dB to 10 dB
Category T2	10 dB to 20 dB
Category T3	20 dB to 30 dB
Category T4	> 30 dB

Table 3: T-Coil signal quality categories



Unless otherwise agreed in writing, this document is issued by the Company subject to its General Conditions of Service printed overleaf, available on request or accessible at <http://www.sgs.com/en/Terms-and-Conditions.aspx> and, for electronic format documents, subject to Terms and Conditions for Electronic Documents at <http://www.sgs.com/en/Terms-and-Conditions/Terms-e-Documents.aspx>. Attention is drawn to the limitation of liability, indemnification and jurisdiction issues defined therein. Any holder of this document is advised that information contained hereon reflects the Company's findings at the time of its intervention only and within the limits of Client's instructions, if any. The Company's sole responsibility is to its Client and this document does not exonerate parties to a transaction from exercising all their rights and obligations under the transaction documents. This document cannot be reproduced except in full, without prior written approval of the Company. Any unauthorized alteration, forgery or falsification of the content or appearance of this document is unlawful and offenders may be prosecuted to the fullest extent of the law. Unless otherwise stated the results shown in this test report refer only to the sample(s) tested and such sample(s) are retained for 30 days only.

Attention: To check the authenticity of testing / inspection report & certificate, please contact us at telephone: (86-755) 8307 1443, or email: CN.Doccheck@sgs.com

South of No. 6 Plant, No. 1, Runsheng Road, Suzhou Industrial Park, Suzhou Area, China (Jiangsu) Pilot Free Trade Zone 215000  
 中国·苏州·中国(江苏)自由贸易试验区苏州片区苏州工业园区润胜路1号的6号厂房南楼 邮编: 215000

t (86-512) 62992980 www.sgs.com.cn  
 t (86-512) 62992980 sgs.china@sgs.com



## 5.2 T-Coil measurement points and reference plane

Figure 3 illustrate the references and reference plane that shall be used in a typical EUT emissions measurement. The principle of this section is applied to EUT with similar geometry. Please refer to Appendix C for the setup photographs.

- ◆ The area is 5 cm by 5 cm.
- ◆ The area is centered on the audio frequency output transducer of the EUT.
- ◆ The area is in a reference plane, which is defined as the planar area that contains the highest point in the area of the phone that normally rests against the user's ear. It is parallel to the centerline of the receiver area of the phone and is defined by the points of the receiver-end of the EUT handset, which, in normal handset use, rest against the ear.
- ◆ The measurement plane is parallel to, and 10 mm in front of, the reference plane.

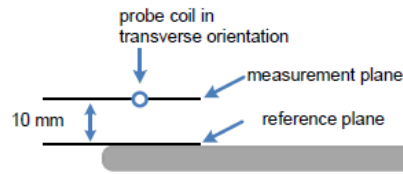
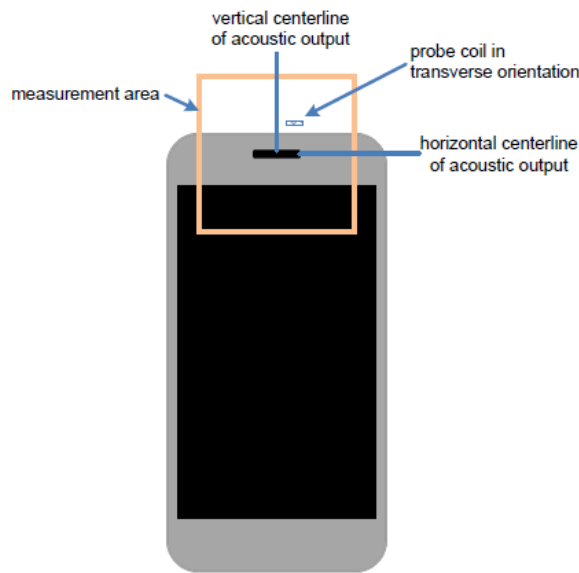

Figure A.4—Measurement and reference planes probe orientation for WD audio frequency magnetic field measurements

Figure 3 Axis and planes for WD audio frequency magnetic field measurements



Unless otherwise agreed in writing, this document is issued by the Company subject to its General Conditions of Service printed overleaf, available on request or accessible at <http://www.sgs.com/en/Terms-and-Conditions.aspx> and, for electronic format documents, subject to Terms and Conditions for Electronic Documents at <http://www.sgs.com/en/Terms-and-Conditions/Terms-e-Documents.aspx>. Attention is drawn to the limitation of liability, indemnification and jurisdiction issues defined therein. Any holder of this document is advised that information contained hereon reflects the Company's findings at the time of its intervention only and within the limits of Client's instructions, if any. The Company's sole responsibility is to its Client and this document does not exonerate parties to a transaction from exercising all their rights and obligations under the transaction documents. This document cannot be reproduced except in full, without prior written approval of the Company. Any unauthorized alteration, forgery or falsification of the content or appearance of this document is unlawful and offenders may be prosecuted to the fullest extent of the law. Unless otherwise stated the results shown in this test report refer only to the sample(s) tested and such sample(s) are retained for 30 days only.

Attention: To check the authenticity of testing / inspection report & certificate, please contact us at telephone: (86-755) 8307 1443, or email: [CN.Doccheck@sgs.com](mailto:CN.Doccheck@sgs.com)

South of No. 6 Plant, No. 1, Runsheng Road, Suzhou Industrial Park, Suzhou Area, China (Jiangsu) Pilot Free Trade Zone 215000

t (86-512) 62992980 www.sgs.com.cn

中国·苏州·中国(江苏)自由贸易试验区苏州片区苏州工业园区润胜路1号的6号厂房南楼 邮编: 215000

t (86-512) 62992980 sgs.china@sgs.com

### 5.3 T-Coil Measurement Procedure

According to ANSI C63.19-2019, section4:

This subclause describes the procedures used to measure the ABM (T-Coi) performance of the WD. Measurements shall be performed over a meastrement area 50 mm square, in the measurement plane, as specified in A.3. The measurement area shall be scanned with a uniform measurement point spacing of 2.0 mm ± 0.5 mm in each X=Y axis of the plane, yielding 676 measurement points with approximately even spacing throughout the area.

Optionally, measurement point spacing may be increased to 4 mm, with interpolation employed to yield the required 676 equivalent measurement points distributed uniformly over the 50 mm square measurement area. Interpolated points shall be derived from the average of the linear representations of the field strengths of the nearest two or four equidistant measured points. The area of measurement is increased to a 52 mm square so that edge rows and columns of the required 50 mm square can be either measured or interpolated with none extrapolated.

In order to assure that the required signal quality is measured, the measurement of the intended signal and the measurement of the unintended signal shall be made at the same locations. Measurements shall not include undesired influence from the WD's RF field; therefore, use of a coaxial connection to a base station simulator or non-radiating load might be necessary. However, even then with a coaxial connection to a base station simulator or non-radiating load there could still be RF leakage from the WD, which could interfere with the desired measurement. Pre-measurement checks should be made to avoid this possibility. All measurements shall be done with the WD operating on battery power with an appropriate normal speech audio signal input level given in Table 6.1. If the device display can be turned off during a phone call, then that may be done during the measurement as well. If tested with the display in the off state this shall be documented in the test report.

Measurements shall be performed with the probe coil oriented in the transverse direction, aligned in the plane of the measurement area and perpendicular to the long dimension of the WD. A multi-stage sequence consists of first measuring the field strength of the desired T-Coil signal(desired ABM signal) that is useful to a hearing aid.

T-Coil at each specified measurement point. The undesired magnetic component (undesired ABM field) is then measured in the same transverse orientation at each of the same measurement point.

The following steps summarize the basic test flow for determining desired ABM signal and undesired ABM field. These steps assume that a sine wave or narrowband 1/3 octave signal can be used for the measurement of desired ABM signal level.

To minimize the need to test every WD operating mode to the telecoil requirements of Clause 6, it is permissible to exclude some subset of supported configurations. For a given WD, every mode that supports voice communication shall be considered for telecoil testing. However, if it can be demonstrated that a certain confi guration will not be the worst-case telecoil configuration, such configurations may be excluded from the fall telecoil scans of 6.4.}4 For example, operating modes may be pre-screened by scanning for both desired ABM signal and udesired ABM field at a lower measurement point density than the final scans, thus saving considerable testing time by eliminating configurations that are excellent performers from more detailed testing for worst-case.

Many factors could affect telecoil test results. RF power level and amplitude modulation characteristics as well as the specific curent paths within the WD associated with the RF output stage(s), the display, and processing circuitry could affect the undesired ABM field. Audio codec implementation and acoustic receiver characteristics could also affect the desired ABM signal).



Unless otherwise agreed in writing, this document is issued by the Company subject to its General Conditions of Service printed overleaf, available on request or accessible at <http://www.sgs.com/en/Terms-and-Conditions.aspx> and, for electronic format documents, subject to Terms and Conditions for Electronic Documents at <http://www.sgs.com/en/Terms-and-Conditions/Terms-e-Documents.aspx>. Attention is drawn to the limitation of liability, indemnification and jurisdiction issues defined therein. Any holder of this document is advised that information contained hereon reflects the Company's findings at the time of its intervention only and within the limits of Client's instructions, if any. The Company's sole responsibility is to its Client and this document does not exonerate parties to a transaction from exercising all their rights and obligations under the transaction documents. This document cannot be reproduced except in full, without prior written approval of the Company. Any unauthorized alteration, forgery or falsification of the content or appearance of this document is unlawful and offenders may be prosecuted to the fullest extent of the law. Unless otherwise stated the results shown in this test report refer only to the sample(s) tested and such sample(s) are retained for 30 days only.

Attention: To check the authenticity of testing /inspection report & certificate, please contact us at telephone: (86-755) 8307 1443, or email: [CN.Doccheck@sgs.com](mailto:CN.Doccheck@sgs.com)

South of No. 6 Plant, No. 1, Runsheng Road, Suzhou Industrial Park, Suzhou Area, China (Jiangsu) Pilot Free Trade Zone 215000 t (86-512) 62992980 www.sgsgroup.com.cn  
 中国·苏州·中国(江苏)自由贸易试验区苏州片区苏州工业园区润胜路1号的6号厂房南楼 邮编: 215000 t (86-512) 62992980 sgs.china@sgs.com

## 6 T-Coil testing for CMRS Voice

### 6.1 General Description

#### 1. Codec Investigation:

This clause describes the measurement of the baseband (audio frequency) magnetic T-Coil signal from a WD. The goal is to evaluate the size of the area where a user could position their WD relative to their hearing aid's telecoil and receive an acceptable magnetically coupled signal. Three quantities are measured and evaluated. The first is the field strength of the desired signal at the center of the audio band (desired ABM signal). The second is the frequency response of the desired signal measured across the audio band. The third is the field strength of the undesired audio band magnetic field.

#### 2. Air Interface Investigation:

- Use the worst-case codec test and document a limited set of bands/channel/bandwidths. Observe the effect of changing the band and bandwidth to ensure that there are no unexpected variations. Using the knowledge of the observed variations, it is necessary to report only a set band/channel/bandwidth for each orientation for a voice service/air interface.
- According to the ANSI C63.19 2019 section 6.3.4, test middle channel of each frequency band for HAC testing for each orientation to determine worst HAC T-Coil.
- Opening the Hearing-aid can improve the HAC T-Coil performance of the earpiece.

### 6.2 GSM Tests Results

#### Codec Investigation:

Air Interface	Modulation	Channel	Codec	Primary Group Contiguous Point Count	Secondary Group Contiguous Point Count	Frequency Response	Date
GSM850	Voice	190	AMR NB FR	278	444	PASS	2023-11-18
GSM850	Voice	190	EFR (FR V2)	276	441	PASS	2023-11-18
GSM850	Voice	190	AMR WB FR	275	438	PASS	2023-11-18

Remark: According to codec investigation, the worst codec is AMR WB FR

#### Air Interface Investigation:

Air Interface	Modulation	Channel	Codec	Primary Group Contiguous Point Count	Secondary Group Contiguous Point Count	Frequency Response	Date
GSM850	Voice	190	AMR WB FR	275	438	PASS	2023/11/18
GSM1900	Voice	661	AMR WB FR	282	443	PASS	2023/11/18

#### Remark:

- Phone Condition: Air Link; Hearing-aid on; Mute on; Backlight off; Max Volume
- The detail frequency response results please refer to appendix A.



Unless otherwise agreed in writing, this document is issued by the Company subject to its General Conditions of Service printed overleaf, available on request or accessible at <http://www.sgs.com/en/Terms-and-Conditions.aspx> and, for electronic format documents, subject to Terms and Conditions for Electronic Documents at <http://www.sgs.com/en/Terms-and-Conditions/Terms-e-Documents.aspx>. Attention is drawn to the limitation of liability, indemnification and jurisdiction issues defined therein. Any holder of this document is advised that information contained hereon reflects the Company's findings at the time of its intervention only and within the limits of Client's instructions, if any. The Company's sole responsibility is to its Client and this document does not exonerate parties to a transaction from exercising all their rights and obligations under the transaction documents. This document cannot be reproduced except in full, without prior written approval of the Company. Any unauthorized alteration, forgery or falsification of the content or appearance of this document is unlawful and offenders may be prosecuted to the fullest extent of the law. Unless otherwise stated the results shown in this test report refer only to the sample(s) tested and such sample(s) are retained for 30 days only.

Attention: To check the authenticity of testing/inspection report & certificate, please contact us at telephone: (86-755) 8307 1443, or email: CN.Doccheck@sgs.com

South of No. 6 Plant, No. 1, Runsheng Road, Suzhou Industrial Park, Suzhou Area, China (Jiangsu) Pilot Free Trade Zone 215000

t (86-512) 62992980 www.sgs.com.cn

中国·苏州·中国(江苏)自由贸易试验区苏州片区苏州工业园区湖胜路1号的6号厂房南楼 邮编: 215000

t (86-512) 62992980 sgs.china@sgs.com

### 6.3 UMTS Tests Results

#### Codec Investigation:

Air Interface	Modulation	Channel	Codec	Primary Group Contiguous Point Count	Secondary Group Contiguous Point Count	Secondary Group Max Longitudinal	Secondary Group Max Transverse	Frequency Response	Date
WCDMA II	Voice	9400	AMR NB 4.75Kbps	508	676	26	26	PASS	2023/11/18
WCDMA II	Voice	9400	AMR WB 6.60Kbps	494	676	26	26	PASS	2023/11/18
WCDMA II	Voice	9400	AMR NB12.2Kbps	493	670	26	26	PASS	2023/11/18
WCDMA II	Voice	9400	AMR WB 23.85Kbps	473	656	26	26	PASS	2023/11/18

Remark: According to codec investigation, the worst codec is **AMR WB 23.85Kbps**

#### Air Interface Investigation:

Air Interface	Modulation	Channel	Codec	Primary Group Contiguous Point Count	Secondary Group Contiguous Point Count	Secondary Group Max Longitudinal	Secondary Group Max Transverse	Frequency Response	Date
WCDMA II	Voice	9400	AMR WB 23.85Kbps	473	656	26	26	PASS	2023/11/18
WCDMA V	Voice	4182	AMR WB 23.85Kbps	449	647	26	26	PASS	2023/11/18

**Remark:**

1. Phone Condition: Air Link; Hearing-aid on; Mute on; Backlight off; Max Volume
2. The detail frequency response results please refer to appendix A.



## 7 T-Coil testing for CMRS IP Voice

### 7.1 VoLTE/VONR Tests Results

#### 1. Codec Investigation:

For a voice service/air interface, investigate the variations of codec configurations (WB, NB bit rate) and document the parameters for that voice service. It is only necessary to document this for one channel / band, the following worst investigation codec would be remarked to be used for the testing for the handset.

#### 2. Air Interface Investigation:

a. Use the worst-case codec test and document a limited set of bands / channel / bandwidths. Observe the effect of changing the band and bandwidth to ensure that there are no unexpected variations. Using the knowledge of the observed variations, it is necessary to report only a set band/channel/bandwidth for each orientation for a voice service/air interface and the following worst configure would be remarked to be used for the testing for the handset.

b. Select LTE FDD one frequency band to do measurement at the worst Primary Group Contiguous Point Count position was additionally performed with varying the BWs/Modulations/RB size to verify the variation to find out worst configuration, the observed variation is very little to be within 1.5 dB which is much less than the margin from the rating threshold.

#### LTE FDD Codec Investigation:

Air Interface	BW (MHz)	Modulation	RB Size	RB offset	Channel	Codec	Primary Group Contiguous Point Count	Secondary Group Contiguous Point Count	Secondary Group Max Longitudinal	Secondary Group Max Transverse	Frequency Response	Date
LTE Band2	20	QPSK	1	0	18900	AMR NB 4.75Kbps	454	623	26	26	PASS	2023/11/22
LTE Band2	20	QPSK	1	0	18900	AMR NB 12.2Kbps	481	645	26	26	PASS	2023/11/22
LTE Band2	20	QPSK	1	0	18900	AMR WB 6.60Kbps	478	643	26	26	PASS	2023/11/22
LTE Band2	20	QPSK	1	0	18900	AMR WB 23.85Kbps	483	651	26	26	PASS	2023/11/22
LTE Band2	20	QPSK	1	0	18900	EVS WB 5.9Kbps	466	639	26	26	PASS	2023/11/22
LTE Band2	20	QPSK	1	0	18900	EVS WB 13.2Kbps	470	642	26	26	PASS	2023/11/22
LTE Band2	20	QPSK	1	0	18900	EVS NB 5.9Kbps	471	642	26	26	PASS	2023/11/22
LTE Band2	20	QPSK	1	0	18900	EVS NB 13.2Kbps	453	625	26	26	PASS	2023/11/22
LTE Band2	20	QPSK	50	0	18900	EVS NB 13.2Kbps	462	633	26	26	PASS	2023/11/22
LTE Band2	20	QPSK	100	0	18900	EVS NB 13.2Kbps	473	644	26	26	PASS	2023/11/22
LTE Band2	20	16QAM	1	0	18900	EVS NB 13.2Kbps	472	643	26	26	PASS	2023/11/22
LTE Band2	20	64QAM	1	0	18900	EVS NB 13.2Kbps	474	646	26	26	PASS	2023/11/22
LTE Band2	20	256QAM	1	0	18900	EVS NB 13.2Kbps	461	633	26	26	PASS	2023/11/22
LTE Band2	15	QPSK	1	0	18900	EVS NB 13.2Kbps	458	633	26	26	PASS	2023/11/22
LTE Band2	10	QPSK	1	0	18900	EVS NB 13.2Kbps	470	632	26	26	PASS	2023/11/22
LTE Band2	5	QPSK	1	0	18900	EVS NB 13.2Kbps	484	643	26	26	PASS	2023/11/22
LTE Band2	3	QPSK	1	0	18900	EVS NB 13.2Kbps	483	648	26	26	PASS	2023/11/22
LTE Band2	1.4	QPSK	1	0	18900	EVS NB 13.2Kbps	478	642	26	26	PASS	2023/11/22

Remark:

- Select Worst worst codec Bandwidth/Modulation/RB Size from LTE FDD Test results to do LTE FDD
- Select Worst Bandwidth/Modulation/RB Size from LTE FDD Test results to do LTE FDD
- According to codec investigation, the worst codec is **EVS NB 13.2Kbps**



Unless otherwise agreed in writing, this document is issued by the Company subject to its General Conditions of Service printed overleaf, available on request or accessible at <http://www.sgs.com/en/Terms-and-Conditions.aspx> and, for electronic format documents, subject to Terms and Conditions for Electronic Documents at <http://www.sgs.com/en/Terms-and-Conditions/Terms-e-Documents.aspx>. Attention is drawn to the limitation of liability, indemnification and jurisdiction issues defined therein. Any holder of this document is advised that information contained hereon reflects the Company's findings at the time of its intervention only and within the limits of Client's instructions, if any. The Company's sole responsibility is to its Client and this document does not exonerate parties to a transaction from exercising all their rights and obligations under the transaction documents. This document cannot be reproduced except in full, without prior written approval of the Company. Any unauthorized alteration, forgery or falsification of the content or appearance of this document is unlawful and offenders may be prosecuted to the fullest extent of the law. Unless otherwise stated the results shown in this test report refer only to the sample(s) tested and such sample(s) are retained for 30 days only.

Attention: To check the authenticity of testing / inspection report & certificate, please contact us at telephone: (86-755) 8307 1443, or email: [CN.Doccheck@sgs.com](mailto:CN.Doccheck@sgs.com)

South of No. 6 Plant, No. 1, Runsheng Road, Suzhou Industrial Park, Suzhou Area, China (Jiangsu) Pilot Free Trade Zone 215000 t (86-512) 62992980 www.sgs.com.cn  
 中国·苏州·中国(江苏)自由贸易试验区苏州片区苏州工业园区润胜路1号的6号厂房南楼 邮编: 215000 t (86-512) 62992980 sgs.china@sgs.com

**Air interface:**

Air Interface	BW (MHz)	Modulation	RB Size	RB offset	Channel	Codec	Primary Group Contiguous Point Count	Secondary Group Contiguous Point Count	Secondary Group Max Longitudinal	Secondary Group Max Transverse	Frequency Response	Date
LTE Band2	20	QPSK	1	0	18900	EVS NB 13.2Kbps	453	625	26	26	PASS	2023/11/23
LTE Band4	20	QPSK	1	0	20175	EVS NB 13.2Kbps	312	476	26	26	PASS	2023/11/23
LTE Band5	10	QPSK	1	0	20525	EVS NB 13.2Kbps	488	650	26	26	PASS	2023/11/23
LTE Band12	10	QPSK	1	0	23095	EVS NB 13.2Kbps	138	647	26	26	PASS	2023/11/23
LTE Band14	10	QPSK	1	0	23330	EVS NB 13.2Kbps	138	630	26	26	PASS	2023/11/23
LTE Band17	10	QPSK	1	0	23790	EVS NB 13.2Kbps	138	630	26	26	PASS	2023/11/23
LTE Band26	15	QPSK	1	0	26865	EVS NB 13.2Kbps	462	649	26	26	PASS	2023/11/23
LTE Band30	10	QPSK	1	0	27710	EVS NB 13.2Kbps	459	646	26	26	PASS	2023/11/23
LTE Band66	20	QPSK	1	0	132322	EVS NB 13.2Kbps	453	644	26	26	PASS	2023/11/23
LTE Band71	20	QPSK	1	0	133297	EVS NB 13.2Kbps	460	650	26	26	PASS	2023/11/23

**Remark:**

1. Phone Condition: Air Link; Hearing-aid on; Mute on; Backlight off; Max Volume
2. The detail frequency response results please refer to appendix A

**LTE TDD Codec Investigation:**

Air Interface	BW (MHz)	Modulation	RB Size	RB offset	Channel	UL-DL Configuration	Codec	Primary Group Contiguous Point Count	Secondary Group Contiguous Point Count	Secondary Group Max Longitudinal	Secondary Group Max Transverse	Frequency Response	Date
LTE Band48	20	QPSK	1	0	55990	0	AMR NB 4.75Kbps	405	500	22	26	PASS	2023/11/26
LTE Band48	20	QPSK	1	0	55990	0	AMR NB 12.2Kbps	407	500	22	26	PASS	2023/11/26
LTE Band48	20	QPSK	1	0	55990	0	AMR WB 6.6Kbps	407	500	22	26	PASS	2023/11/26
LTE Band48	20	QPSK	1	0	55990	0	AMR WB 23.85Kbps	307	398	19	26	PASS	2023/11/26
LTE Band48	20	QPSK	1	0	55990	0	EVS NB 5.9Kbps	286	396	19	26	PASS	2023/11/26
LTE Band48	20	QPSK	1	0	55990	0	EVS NB 13.2Kbps	410	501	22	26	PASS	2023/11/26
LTE Band48	20	QPSK	1	0	55990	0	EVS WB 5.9Kbps	290	402	19	26	PASS	2023/11/26
LTE Band48	20	QPSK	1	0	55990	0	EVS WB 13.2Kbps	315	402	19	26	PASS	2023/11/26
LTE Band48	20	QPSK	50	0	55990	0	EVS NB 5.9Kbps	314	411	20	26	PASS	2023/11/26
LTE Band48	20	QPSK	100	0	55990	0	EVS NB 5.9Kbps	302	404	19	26	PASS	2023/11/26
LTE Band48	20	16QAM	1	0	55990	0	EVS NB 5.9Kbps	312	413	20	26	PASS	2023/11/26
LTE Band48	20	64QAM	1	0	55990	0	EVS NB 5.9Kbps	314	415	20	26	PASS	2023/11/26
LTE Band48	20	256QAM	1	0	55990	0	EVS NB 5.9Kbps	311	413	20	26	PASS	2023/11/26
LTE Band48	15	QPSK	1	0	55990	0	EVS NB 5.9Kbps	288	393	19	26	PASS	2023/11/26
LTE Band48	10	QPSK	1	0	55990	0	EVS NB 5.9Kbps	297	405	19	26	PASS	2023/11/26
LTE Band48	5	QPSK	1	0	55990	0	EVS NB 5.9Kbps	299	411	20	26	PASS	2023/11/26

**Remark:**

1. Select Worst worst codec Bandwidth/Modulation/RB Size from LTE TDD Test results to do LTE TDD
2. Select Worst Bandwidth/Modulation/RB Size from LTE TDD Test results to do LTE TDD
3. According to codec investigation, the worst codec is **NB EVS 5.90kbps**

**LTE TDD Air interface:**

Air Interface	BW (MHz)	Modulation	RB Size	RB offset	Channel	UL-DL Configuration	Codec	Primary Group Contiguous Point Count	Secondary Group Contiguous Point Count	Secondary Group Max Longitudinal	Secondary Group Max Transverse	Frequency Response	Date
LTE Band48	20	QPSK	1	0	55990	0	EVS NB 5.9Kbps	286	396	19	26	PASS	2023/11/26

**Remark:**

1. Phone Condition: Air Link; Hearing-aid on; Mute on; Backlight off; Max Volume
2. The detail frequency response results please refer to appendix A



Unless otherwise agreed in writing, this document is issued by the Company subject to its General Conditions of Service printed overleaf, available on request or accessible at <http://www.sgs.com/en/Terms-and-Conditions.aspx> and, for electronic format documents, subject to Terms and Conditions for Electronic Documents at <http://www.sgs.com/en/Terms-and-Conditions/Terms-e-Documents.aspx>. Attention is drawn to the limitation of liability, indemnification and jurisdiction issues defined therein. Any holder of this document is advised that information contained hereon reflects the Company's findings at the time of its intervention only and within the limits of Client's instructions, if any. The Company's sole responsibility is to its Client and this document does not exonerate parties to a transaction from exercising all their rights and obligations under the transaction documents. This document cannot be reproduced except in full, without prior written approval of the Company. Any unauthorized alteration, forgery or falsification of the content or appearance of this document is unlawful and offenders may be prosecuted to the fullest extent of the law. Unless otherwise stated the results shown in this test report refer only to the sample(s) tested and such sample(s) are retained for 30 days only.

**Attention: To check the authenticity of testing / inspection report & certificate, please contact us at telephone: (86-755) 8307 1443, or email: CN.Doccheck@sgs.com**

South of No. 6 Plant, No. 1, Runsheng Road, Suzhou Industrial Park, Suzhou Area, China (Jiangsu) Pilot Free Trade Zone 215000 t (86-512) 62992980 www.sgs.com.cn  
 中国·苏州·中国(江苏)自由贸易试验区苏州片区苏州工业园区润胜路1号的6号厂房南楼 邮编: 215000 t (86-512) 62992980 sgs.china@sgs.com

**FR1 NR Codec Investigation:**

Air Interface	BW (MHz)	Modulation	RB Size	RB offset	Channel	Codec	Primary Group Contiguous Point Count	Secondary Group Contiguous Point Count	Secondary Group Max Longitudinal	Secondary Group Max Transverse	Frequency Response	Date
FR1 n77	100	DFT-s-OFDM QPSK	1	1	656000	AMR NB 4.75Kbps	177	323	18	26	PASS	2023/12/23
FR1 n77	100	DFT-s-OFDM QPSK	1	1	656000	AMR NB 12.2Kbps	180	322	18	26	PASS	2023/12/23
FR1 n77	100	DFT-s-OFDM QPSK	1	1	656000	AMR WB 6.6Kbps	152	322	18	26	PASS	2023/12/23
FR1 n77	100	DFT-s-OFDM QPSK	1	1	656000	AMR WB 23.85Kbps	153	315	17	26	PASS	2023/12/23
FR1 n77	100	DFT-s-OFDM QPSK	1	1	656000	EVS NB 5.9Kbps	158	324	19	26	PASS	2023/12/23
FR1 n77	100	DFT-s-OFDM QPSK	1	1	656000	EVS NB 13.2Kbps	202	339	18	26	PASS	2023/12/23
FR1 n77	100	DFT-s-OFDM QPSK	1	1	656000	EVS WB 5.9Kbps	144	332	18	26	PASS	2023/12/23
FR1 n77	100	DFT-s-OFDM QPSK	1	1	656000	EVS WB 13.2Kbps	188	337	18	26	PASS	2023/12/23
FR1 n77	100	DFT-s-OFDM QPSK	50	0	656000	EVS WB 5.9Kbps	152	334	18	26	PASS	2023/12/23
FR1 n77	100	DFT-s-OFDM QPSK	100	0	656000	EVS WB 5.9Kbps	163	343	18	26	PASS	2023/12/23
FR1 n77	100	DFT-s-OFDM 16QAM	1	1	656000	EVS WB 5.9Kbps	146	332	18	26	PASS	2023/12/23
FR1 n77	100	DFT-s-OFDM 64QAM	1	1	656000	EVS WB 5.9Kbps	146	331	18	26	PASS	2023/12/23
FR1 n77	100	DFT-s-OFDM 256QAM	1	1	656000	EVS WB 5.9Kbps	194	378	19	26	PASS	2023/12/23
FR1 n77	100	DFT-PI/2 BPSK	1	1	656000	EVS WB 5.9Kbps	175	359	19	26	PASS	2023/12/23
FR1 n77	100	CP-OFDM QPSK	1	1	656000	EVS WB 5.9Kbps	165	354	19	26	PASS	2023/12/23
FR1 n77	90	DFT-s-OFDM QPSK	1	1	656000	EVS WB 5.9Kbps	174	358	19	26	PASS	2023/12/23
FR1 n77	80	DFT-s-OFDM QPSK	1	1	656000	EVS WB 5.9Kbps	176	356	19	26	PASS	2023/12/23
FR1 n77	60	DFT-s-OFDM QPSK	1	1	656000	EVS WB 5.9Kbps	170	355	19	26	PASS	2023/12/23
FR1 n77	50	DFT-s-OFDM QPSK	1	1	656000	EVS WB 5.9Kbps	160	354	19	26	PASS	2023/12/23
FR1 n77	40	DFT-s-OFDM QPSK	1	1	656000	EVS WB 5.9Kbps	152	335	18	26	PASS	2023/12/23
FR1 n77	20	DFT-s-OFDM QPSK	1	1	656000	EVS WB 5.9Kbps	148	334	18	26	PASS	2023/12/23
FR1 n77	15	DFT-s-OFDM QPSK	1	1	656000	EVS WB 5.9Kbps	159	343	18	26	PASS	2023/12/23
FR1 n77	10	DFT-s-OFDM QPSK	1	1	656000	EVS WB 5.9Kbps	163	355	18	26	PASS	2023/12/23
FR1 n2	5	DFT-s-OFDM QPSK	1	1	376000	EVS WB 5.9Kbps	425	672	26	26	PASS	2023/12/23

**Remark:**

- Select Worst worst codec Bandwidth/Modulation/RB Size from FR1 NR Test results to do FR1 NR
- Select Worst Bandwidth/Modulation/RB Size from FR1 NR Test results to do FR1 NR
- According to codec investigation, the worst codec is **EVS WB 5.9Kbps**



Unless otherwise agreed in writing, this document is issued by the Company subject to its General Conditions of Service printed overleaf, available on request or accessible at <http://www.sgs.com/en/Terms-and-Conditions.aspx> and, for electronic format documents, subject to Terms and Conditions for Electronic Documents at <http://www.sgs.com/en/Terms-and-Conditions/Terms-e-Documents.aspx>. Attention is drawn to the limitation of liability, indemnification and jurisdiction issues defined therein. Any holder of this document is advised that information contained hereon reflects the Company's findings at the time of its intervention only and within the limits of Client's instructions, if any. The Company's sole responsibility is to its Client and this document does not exonerate parties to a transaction from exercising all their rights and obligations under the transaction documents. This document cannot be reproduced except in full, without prior written approval of the Company. Any unauthorized alteration, forgery or falsification of the content or appearance of this document is unlawful and offenders may be prosecuted to the fullest extent of the law. Unless otherwise stated the results shown in this test report refer only to the sample(s) tested and such sample(s) are retained for 30 days only.

Attention: To check the authenticity of testing/inspection report & certificate, please contact us at telephone: (86-755) 8307 1443, or email: [CN.Doccheck@sgs.com](mailto:CN.Doccheck@sgs.com)

South of No. 6 Plant, No. 1, Runsheng Road, Suzhou Industrial Park, Suzhou Area, China (Jiangsu) Pilot Free Trade Zone 215000 t (86-512) 62992980 www.sgs.com.cn  
 中国·苏州·中国(江苏)自由贸易试验区苏州片区苏州工业园区润胜路1号的6号厂房南楼 邮编: 215000 t (86-512) 62992980 sgs.china@sgs.com

**VONR Air interface:**

Air Interface	BW (MHz)	Modulation	RB Size	RB offset	Channel	Codec	Primary Group Contiguous Point Count	Secondary Group Contiguous Point Count	Secondary Group Max Longitudinal	Secondary Group Max Transverse	Frequency Response	Date
FR1 n2	20	DFT-s-OFDM QPSK	1	1	376000	EVS WB 5.9Kbps	393	650	26	26	PASS	2023/12/24
FR1 n5	20	DFT-s-OFDM QPSK	1	1	167300	EVS WB 5.9Kbps	410	676	26	26	PASS	2023/12/24
FR1 n25	20	DFT-s-OFDM QPSK	1	1	376500	EVS WB 5.9Kbps	417	673	26	26	PASS	2023/12/24
FR1 n26	20	DFT-s-OFDM QPSK	1	1	166300	EVS WB 5.9Kbps	341	675	26	26	PASS	2023/12/24
FR1 n30	10	DFT-s-OFDM QPSK	1	1	462000	EVS WB 5.9Kbps	419	674	26	26	PASS	2023/12/24
FR1 n41	20	DFT-s-OFDM QPSK	1	1	518598	EVS WB 5.9Kbps	138	324	18	26	PASS	2023/12/24
FR1 n48	20	DFT-s-OFDM QPSK	1	1	641666	EVS WB 5.9Kbps	266	458	21	26	PASS	2023/12/24
FR1 n66	20	DFT-s-OFDM QPSK	1	1	349000	EVS WB 5.9Kbps	402	655	26	26	PASS	2023/12/24
FR1 n70	15	DFT-s-OFDM QPSK	1	1	340500	EVS WB 5.9Kbps	435	655	26	26	PASS	2023/12/24
FR1 n71	20	DFT-s-OFDM QPSK	1	1	136100	EVS WB 5.9Kbps	449	676	26	26	PASS	2023/12/24

**Remark:**

1. Phone Condition: Air Link; Hearing-aid on; Mute on; Backlight off; Max Volume
2. The detail frequency response results please refer to appendix A



Unless otherwise agreed in writing, this document is issued by the Company subject to its General Conditions of Service printed overleaf, available on request or accessible at <http://www.sgs.com/en/Terms-and-Conditions.aspx> and, for electronic format documents, subject to Terms and Conditions for Electronic Documents at <http://www.sgs.com/en/Terms-and-Conditions/Terms-e-Documents.aspx>. Attention is drawn to the limitation of liability, indemnification and jurisdiction issues defined therein. Any holder of this document is advised that information contained hereon reflects the Company's findings at the time of its intervention only and within the limits of Client's instructions, if any. The Company's sole responsibility is to its Client and this document does not exonerate parties to a transaction from exercising all their rights and obligations under the transaction documents. This document cannot be reproduced except in full, without prior written approval of the Company. Any unauthorized alteration, forgery or falsification of the content or appearance of this document is unlawful and offenders may be prosecuted to the fullest extent of the law. Unless otherwise stated the results shown in this test report refer only to the sample(s) tested and such sample(s) are retained for 30 days only.

Attention: To check the authenticity of testing / inspection report & certificate, please contact us at telephone: (86-755) 8307 1443, or email: [CN.Doccheck@sgs.com](mailto:CN.Doccheck@sgs.com)



## 7.2 VoWiFi Tests Results

### 1. Codec Investigation:

For a voice service/air interface, investigate the variations of codec configurations (WB, NB bit rate) and document the parameters for that voice service. It is only necessary to document this for one channel/band, the following worst investigation codec would be remarked to be used for the testing for the handset.

### 2. Air Interface Investigation:

a. Use the worst-case codec test and document a limited set of bands/channel/bandwidths. Observe the effect of changing the band and bandwidth to ensure that there are no unexpected variations. Using the knowledge of the observed variations, it is necessary to report only a set band/channel/bandwidth for each orientation for a voice service/air interface and the following worst configuration would be remarked to be used for the testing for the handset.

b. Select WLAN 2.4GHz and WLAN5GHz one frequency band to do measurement at the worst Primary Group Contiguous Point Count position was additionally performed with varying the BWs/Modulations/data rate to verify the variation to find out worst configuration, the observed variation is very little to be within 1 dB which is much less than the margin from the rating threshold.

Air Interface	BW (MHz)	Modulation	Channel	Codec	Primary Group Contiguous Point Count	Secondary Group Contiguous Point Count	Secondary Group Max Longitudinal	Secondary Group Max Transverse	Frequency Response	Date
802.11b	20	1M	6	AMR NB 4.75Kbps	283	443	23	26	PASS	2023/12/26
802.11b	20	1M	6	AMR WB 6.60Kbps	315	476	26	26	PASS	2023/12/26
802.11b	20	1M	6	AMR NB12.2Kbps	300	456	26	26	PASS	2023/12/26
802.11b	20	1M	6	AMR WB 23.85Kbps	293	455	25	26	PASS	2023/12/26
802.11b	20	1M	6	EVS WB 5.9Kbps	379	562	26	26	PASS	2023/12/26
802.11b	20	1M	6	EVS WB 13.2Kbps	327	506	24	26	PASS	2023/12/26
802.11b	20	1M	6	EVS NB 5.9Kbps	319	502	26	26	PASS	2023/12/26
802.11b	20	1M	6	EVS NB 13.2Kbps	322	504	26	26	PASS	2023/12/26
802.11b	20	11M	6	AMR NB 4.75Kbps	327	506	24	26	PASS	2023/12/26
802.11g	20	6M	6	AMR NB 4.75Kbps	139	429	26	26	PASS	2023/12/26
802.11g	20	54M	6	AMR NB 4.75Kbps	221	473	26	26	PASS	2023/12/26
802.11n-HT20	20	MCS0	6	AMR NB 4.75Kbps	428	656	26	26	PASS	2023/12/26
802.11n-HT20	20	MCS7	6	AMR NB 4.75Kbps	134	426	26	26	PASS	2023/12/26
802.11n-HT40	40	MCS0	6	AMR NB 4.75Kbps	282	546	26	26	PASS	2023/12/26
802.11n-HT40	40	MCS7	6	AMR NB 4.75Kbps	335	554	26	26	PASS	2023/12/26
802.11a	20	6M	40	AMR NB 4.75Kbps	149	369	18	26	PASS	2023/12/26
802.11a	20	54M	40	AMR NB 4.75Kbps	150	371	19	26	PASS	2023/12/26
802.11n-HT20	20	MCS0	40	AMR NB 4.75Kbps	142	362	18	26	PASS	2023/12/26
802.11n-HT20	20	MCS7	40	AMR NB 4.75Kbps	150	370	19	26	PASS	2023/12/26
802.11n-HT40	40	MCS0	38	AMR NB 4.75Kbps	261	481	26	26	PASS	2023/12/26
802.11n-HT40	40	MCS7	38	AMR NB 4.75Kbps	219	436	22	26	PASS	2023/12/26
802.11ac-VHT20	20	MCS0	40	AMR NB 4.75Kbps	211	431	21	26	PASS	2023/12/26
802.11ac-VHT20	20	MCS7	40	AMR NB 4.75Kbps	221	440	22	26	PASS	2023/12/26
802.11ac-VHT40	40	MCS0	38	AMR NB 4.75Kbps	255	474	25	26	PASS	2023/12/26
802.11ac-VHT40	40	MCS7	38	AMR NB 4.75Kbps	256	478	25	26	PASS	2023/12/26
802.11ac-VHT80	80	MCS0	42	AMR NB 4.75Kbps	253	473	25	26	PASS	2023/12/26
802.11ac-VHT80	80	MCS7	42	AMR NB 4.75Kbps	251	470	25	26	PASS	2023/12/26

Remark:

- According to codec investigation, the worst codec is **NB AMR 4.75kbps**
- According to codec investigation, WiFi 2.4G the worst codec is **802.11n-HT20 MCS7**, WiFi 5G the worst codec is **802.11n-HT20 MCS0**



Unless otherwise agreed in writing, this document is issued by the Company subject to its General Conditions of Service printed overleaf, available on request or accessible at <http://www.sgs.com/en/Terms-and-Conditions.aspx> and, for electronic format documents, subject to Terms and Conditions for Electronic Documents at <http://www.sgs.com/en/Terms-and-Conditions/Terms-e-Documents.aspx>. Attention is drawn to the limitation of liability, indemnification and jurisdiction issues defined therein. Any holder of this document is advised that information contained hereon reflects the Company's findings at the time of its intervention only and within the limits of Client's instructions, if any. The Company's sole responsibility is to its Client and this document does not exonerate parties to a transaction from exercising all their rights and obligations under the transaction documents. This document cannot be reproduced except in full, without prior written approval of the Company. Any unauthorized alteration, forgery or falsification of the content or appearance of this document is unlawful and offenders may be prosecuted to the fullest extent of the law. Unless otherwise stated the results shown in this test report refer only to the sample(s) tested and such sample(s) are retained for 30 days only.

Attention: To check the authenticity of testing/inspection report & certificate, please contact us at telephone: (86-755) 8307 1443, or email: [CN.Doccheck@sgs.com](mailto:CN.Doccheck@sgs.com)  
 South of No. 6 Plant, No. 1, Runsheng Road, Suzhou Industrial Park, Suzhou Area, China (Jiangsu) Pilot Free Trade Zone 215000 t (86-512) 62992980 www.sgs.com.cn  
 中国·苏州·中国(江苏)自由贸易试验区苏州片区苏州工业园区润胜路1号的6号厂房南楼 邮编: 215000 t (86-512) 62992980 sgs.china@sgs.com

**Air interface:**

Air Interface	BW (MHz)	Modulation	Channel	Codec	Primary Group Contiguous Point Count	Secondary Group Contiguous Point Count	Secondary Group Max Longitudinal	Secondary Group Max Transverse	Frequency Response	Date
802.11n-HT20	20	MCS7	6	AMR NB 4.75Kbps	134	426	26	26	PASS	2023/12/27
802.11ac-VHT20	20	MCS0	40	AMR NB 4.75Kbps	211	431	21	26	PASS	2023/12/27
802.11n-HT20	20	MCS0	56	AMR NB 4.75Kbps	213	432	21	26	PASS	2023/12/27
802.11n-HT20	20	MCS0	116	AMR NB 4.75Kbps	236	455	22	26	PASS	2023/12/27
802.11n-HT20	20	MCS0	157	AMR NB 4.75Kbps	221	441	21	26	PASS	2023/12/27

**Remark:**

1. Phone Condition: Air Link; Hearing-aid on; Mute on; Backlight off; Max Volume
2. The detail frequency response results please refer to appendix A.



SGS-CSTC Standards Technical Services (Suzhou) Co., Ltd.  
Wireless Laboratory

Unless otherwise agreed in writing, this document is issued by the Company subject to its General Conditions of Service printed overleaf, available on request or accessible at <http://www.sgs.com/en/Terms-and-Conditions.aspx> and, for electronic format documents, subject to Terms and Conditions for Electronic Documents at <http://www.sgs.com/en/Terms-and-Conditions/Terms-e-Documents.aspx>. Attention is drawn to the limitation of liability, indemnification and jurisdiction issues defined therein. Any holder of this document is advised that information contained hereon reflects the Company's findings at the time of its intervention only and within the limits of Client's instructions, if any. The Company's sole responsibility is to its Client and this document does not exonerate parties to a transaction from exercising all their rights and obligations under the transaction documents. This document cannot be reproduced except in full, without prior written approval of the Company. Any unauthorized alteration, forgery or falsification of the content or appearance of this document is unlawful and offenders may be prosecuted to the fullest extent of the law. Unless otherwise stated the results shown in this test report refer only to the sample(s) tested and such sample(s) are retained for 30 days only.  
**Attention: To check the authenticity of testing /inspection report & certificate, please contact us at telephone: (86-755) 8307 1443, or email: CN.Doccheck@sgs.com**

South of No. 6 Plant, No. 1, Runsheng Road, Suzhou Industrial Park, Suzhou Area, China (Jiangsu) Pilot Free Trade Zone 215000 t (86-512) 62992980 www.sgs.com.cn  
中国·苏州·中国(江苏)自由贸易试验区苏州片区苏州工业园区润胜路1号的6号厂房南楼 邮编: 215000 t (86-512) 62992980 sgs.china@sgs.com

### 7.3 T-Coil testing for OTT VoIP Application

1. The Google Duo only support OPUS audio codec and support 6kbps to 75kbps bitrate.
2. The test setup used for OTT VoIP call is the DUT connect to the CMW500/CMX500 and via the data application unit on CMW500/CMX500 connection to the Internet, the Auxiliary EUT is connected to the WiFi access point, the channel/Modulation/Frequency bands/data rate is configured on the CMW500/CMX500 for the DUT unit. For the Auxiliary VoIP unit which is used to configure the audio codec rate and determine the audio.
3. Codec Investigation: For a voice service/air interface, investigate the variations of codec configurations (WB, NB bit rate) and document the parameters for that voice service. It is only necessary to document this for one channel/band, the following tests results which the worst-case codec would be remarked to be used for the testing for the handset.
4. Use the worst-case codec test and document a limited set of bands/channel/bandwidths. Observe the effect of changing the band and bandwidth to ensure that there are no unexpected variations. Using the knowledge of the observed variations, it is necessary to report only a set band/channel/bandwidth for each orientation for a voice service/air interface.

**Air interface:**

**GSM:**

Air Interface	Modulation	Channel	Codec	Primary Group Contiguous Point Count	Secondary Group Contiguous Point Count	Secondary Group Max Longitudinal	Secondary Group Max Transverse	Frequency Response	Date
GSM850	EDGE	190	OPUS 6kbps	340	407	19	26	PASS	2024/01/13
GSM850	EDGE	190	OPUS 40kbps	356	415	19	26	PASS	2024/01/13
GSM850	EDGE	190	OPUS 75kbps	351	412	19	26	PASS	2024/01/13

**WCDMA:**

Air Interface	Modulation	Channel	Codec	Primary Group Contiguous Point Count	Secondary Group Contiguous Point Count	Secondary Group Max Longitudinal	Secondary Group Max Transverse	Frequency Response	Date
WCDMA V	HSPA	4182	OPUS 6kbps	569	641	26	26	PASS	2024/01/13
WCDMA V	HSPA	4182	OPUS 40kbps	577	649	26	26	PASS	2024/01/13
WCDMA V	HSPA	4182	OPUS 75kbps	571	644	26	26	PASS	2024/01/13

**FDD LTE:**

Air Interface	BW (MHz)	Modulation	RB Size	RB offset	Channel	Codec	Primary Group Contiguous Point Count	Secondary Group Contiguous Point Count	Secondary Group Max Longitudinal	Secondary Group Max Transverse	Frequency Response	Date
LTE Band14	10	QPSK	1	0	23330	OPUS 6kbps	585	658	26	26	PASS	2024/01/16
LTE Band14	10	QPSK	1	0	23330	OPUS 40kbps	589	659	26	26	PASS	2024/01/16
LTE Band14	10	QPSK	1	0	23330	OPUS 75kbps	607	660	26	26	PASS	2024/01/16

**TDD LTE:**

Air Interface	BW (MHz)	Modulation	RB Size	RB offset	Channel	UL-DL Configuration	Codec	Primary Group Contiguous Point Count	Secondary Group Contiguous Point Count	Secondary Group Max Longitudinal	Secondary Group Max Transverse	Frequency Response	Date
LTE Band48	20	QPSK	1	0	55990	0	OPUS 6kbps	348	410	20	26	PASS	2024/01/20
LTE Band48	20	QPSK	1	0	55990	0	OPUS 40kbps	355	420	20	26	PASS	2024/01/20
LTE Band48	20	QPSK	1	0	55990	0	OPUS 75kbps	359	421	20	26	PASS	2024/01/20



Unless otherwise agreed in writing, this document is issued by the Company subject to its General Conditions of Service printed overleaf, available on request or accessible at <http://www.sgs.com/en/Terms-and-Conditions.aspx> and, for electronic format documents, subject to Terms and Conditions for Electronic Documents at <http://www.sgs.com/en/Terms-and-Conditions/Terms-e-Documents.aspx>. Attention is drawn to the limitation of liability, indemnification and jurisdiction issues defined therein. Any holder of this document is advised that information contained hereon reflects the Company's findings at the time of its intervention only and within the limits of Client's instructions, if any. The Company's sole responsibility is to its Client and this document does not exonerate parties to a transaction from exercising all their rights and obligations under the transaction documents. This document cannot be reproduced except in full, without prior written approval of the Company. Any unauthorized alteration, forgery or falsification of the content or appearance of this document is unlawful and offenders may be prosecuted to the fullest extent of the law. Unless otherwise stated the results shown in this test report refer only to the sample(s) tested and such sample(s) are retained for 30 days only.

Attention: To check the authenticity of testing/inspection report & certificate, please contact us at telephone: (86-755) 8307 1443, or email: CN.Doccheck@sgs.com

South of No. 6 Plant, No. 1, Runsheng Road, Suzhou Industrial Park, Suzhou Area, China (Jiangsu) Pilot Free Trade Zone 215000 t (86-512) 62992980 www.sgs.com.cn  
 中国·苏州·中国(江苏)自由贸易试验区苏州片区苏州工业园区润胜路1号的6号厂房南楼 邮编: 215000 t (86-512) 62992980 sgs.china@sgs.com

**FR1 NR:**

Air Interface	BW (MHz)	Modulation	RB Size	RB offset	Channel	Codec	Primary Group Contiguous Point Count	Secondary Group Contiguous Point Count	Secondary Group Max Longitudinal	Secondary Group Max Transverse	Frequency Response	Date
FR1 n41	20	DFT-s-OFDM QPSK	1	1	518598	OPUS 6kbps	342	407	20	26	PASS	2024/01/26
FR1 n41	20	DFT-s-OFDM QPSK	1	1	518598	OPUS 40kbps	356	416	20	26	PASS	2024/01/26
FR1 n41	20	DFT-s-OFDM QPSK	1	1	518598	OPUS 75kbps	348	411	20	26	PASS	2024/01/26

**WIFI:**

Air Interface	BW (MHz)	Modulation	Channel	Codec	Primary Group Contiguous Point Count	Secondary Group Contiguous Point Count	Secondary Group Max Longitudinal	Secondary Group Max Transverse	Frequency Response	Date
802.11n-HT20	20	MCS7	6	OPUS 6kbps	581	650	26	26	PASS	2024/01/21
802.11n-HT20	20	MCS7	6	OPUS 40kbps	588	653	26	26	PASS	2024/01/21
802.11n-HT20	20	MCS7	6	OPUS 75kbps	587	659	26	26	PASS	2024/01/21
802.11n-HT20	20	MCS0	40	OPUS 6kbps	574	645	26	26	PASS	2024/01/21
802.11n-HT20	20	MCS0	40	OPUS 40kbps	588	652	26	26	PASS	2024/01/21
802.11n-HT20	20	MCS0	40	OPUS 75kbps	590	653	26	26	PASS	2024/01/21

**Remark:**

1. Phone Condition: Air Link; Mute on; Backlight off; Max Volume
2. The detail frequency response results please refer to appendix A.



Unless otherwise agreed in writing, this document is issued by the Company subject to its General Conditions of Service printed overleaf, available on request or accessible at <http://www.sgs.com/en/Terms-and-Conditions.aspx> and, for electronic format documents, subject to Terms and Conditions for Electronic Documents at <http://www.sgs.com/en/Terms-and-Conditions/Terms-e-Documents.aspx>. Attention is drawn to the limitation of liability, indemnification and jurisdiction issues defined therein. Any holder of this document is advised that information contained hereon reflects the Company's findings at the time of its intervention only and within the limits of Client's instructions, if any. The Company's sole responsibility is to its Client and this document does not exonerate parties to a transaction from exercising all their rights and obligations under the transaction documents. This document cannot be reproduced except in full, without prior written approval of the Company. Any unauthorized alteration, forgery or falsification of the content or appearance of this document is unlawful and offenders may be prosecuted to the fullest extent of the law. Unless otherwise stated the results shown in this test report refer only to the sample(s) tested and such sample(s) are retained for 30 days only.

Attention: To check the authenticity of testing/inspection report & certificate, please contact us at telephone: (86-755) 8307 1443, or email: [CN.Doccheck@sgs.com](mailto:CN.Doccheck@sgs.com)

## 8 Equipment list

Equipment	Manufacturer	Model	Serial Number	Calibration Date	Due date of calibration
<input checked="" type="checkbox"/> Software	SPEAG	DASY8	NA	NCR	NCR
<input checked="" type="checkbox"/> DAE	SPEAG	DAE4	1484	2023-06-05	2024-06-04
<input checked="" type="checkbox"/> Audio Magnetic 1D Field Probe	SPEAG	AM1DV3	3115	2023-06-13	2024-06-12
<input checked="" type="checkbox"/> Test Arch SD HAC	SPEAG	NA	NA	NCR	NCR
<input checked="" type="checkbox"/> Audio Magnetic Measuring Instrument	SPEAG	AMMI	1028	NCR	NCR
<input checked="" type="checkbox"/> Audio Magnetic	SPEAG	AMCC	1143	N/A	N/A
<input checked="" type="checkbox"/> Universal Radio Communication Tester	R&S	CMW500	111637	2023-09-13	2024-09-12
<input checked="" type="checkbox"/> RADIO COMMUNICATION TESTR	R&S	CMX500	101930	2023-02-08	2024-02-07
<input checked="" type="checkbox"/> Humidity and Temperature Indicator	MingGao	MingGao	NA	2023-06-15	2024-06-14

Note:

1. All the equipments are within the valid period when the tests are performed.
2. NCR: "No-Calibration Required".

## 9 Calibration certificate

Please see the Appendix B

## 10 Photographs

Please see the Appendix C

## Appendix A: Detailed Test Results

## Appendix B: Calibration certificate

## Appendix C: Photographs

---END---



Unless otherwise agreed in writing, this document is issued by the Company subject to its General Conditions of Service printed overleaf, available on request or accessible at <http://www.sgs.com/en/Terms-and-Conditions.aspx> and, for electronic format documents, subject to Terms and Conditions for Electronic Documents at <http://www.sgs.com/en/Terms-and-Conditions/Terms-e-Documents.aspx>. Attention is drawn to the limitation of liability, indemnification and jurisdiction issues defined therein. Any holder of this document is advised that information contained hereon reflects the Company's findings at the time of its intervention only and within the limits of Client's instructions, if any. The Company's sole responsibility is to its Client and this document does not exonerate parties to a transaction from exercising all their rights and obligations under the transaction documents. This document cannot be reproduced except in full, without prior written approval of the Company. Any unauthorized alteration, forgery or falsification of the content or appearance of this document is unlawful and offenders may be prosecuted to the fullest extent of the law. Unless otherwise stated the results shown in this test report refer only to the sample(s) tested and such sample(s) are retained for 30 days only.

Attention: To check the authenticity of testing /inspection report & certificate, please contact us at telephone: (86-755) 8307 1443, or email: CN.Doccheck@sgs.com

South of No. 6 Plant, No. 1, Runsheng Road, Suzhou Industrial Park, Suzhou Area, China (Jiangsu) Pilot Free Trade Zone 215000  
 中国·苏州·中国(江苏)自由贸易试验区苏州片区苏州工业园区润胜路1号的6号厂房南楼 邮编: 215000

t (86-512) 62992980 www.sgs.com.cn  
 t (86-512) 62992980 sgs.china@sgs.com