

RF TEST REPORT

Applicant COOSEA GROUP (HK)
COMPANY LIMITED

FCC ID 2A28USL112

Product Smart Phone

Model SL112A; SL112C

Report No. R2212A1312-R9

Issue Date March 17, 2023

TA Technology (Shanghai) Co., Ltd. tested the above equipment in accordance with the requirements in **FCC CFR47 Part 15C (2022)**. The test results show that the equipment tested is capable of demonstrating compliance with the requirements as documented in this report.

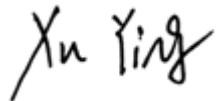

Prepared by: Xu Ying



Approved by: Xu Kai

TA Technology (Shanghai) Co., Ltd.

Building 3, No.145, Jintang Rd, Pudong Shanghai, P.R.China

TEL: +86-021-50791141/2/3

FAX: +86-021-50791141/2/3-8000

TABLE OF CONTENT

1. Test Laboratory	4
1.1. Notes of the test report.....	4
1.2. Test facility	4
1.3. Testing Location.....	4
2. General Description of Equipment under Test.....	5
2.1. Applicant and Manufacturer Information.....	5
2.2. General information.....	5
3. Applied Standards	7
4. Test Configuration	8
5. Test Case	9
5.1. 20dB Bandwidth	9
5.2. Frequency Stability.....	10
5.3. Radiates Emission	12
5.4. Conducted Emission	16
6. Test Results	18
6.1. 20dB Bandwidth	18
6.2. Frequency Stability.....	20
6.3. Radiates Emission	24
6.4. Conducted Emission	28
7. Main Test Instruments.....	30
ANNEX A: The EUT Appearance	31
ANNEX B: Test Setup Photos	32

Summary of measurement results

Number	Test Case	Clause in FCC rules	Verdict
1	20 dB bandwidth	2.1049	PASS
2	Frequency Stability Tolerance	15.225(e)	PASS
3	Radiated Emissions	15.225 (a) (b) (c) (d) and 15.209	PASS
4	Conducted Emissions	15.207	PASS

Date of Testing: January 28, 2023 ~ March 3, 2023

Date of Sample Received: January 11, 2023

Note: PASS: The EUT complies with the essential requirements in the standard.

FAIL: The EUT does not comply with the essential requirements in the standard.

All indications of Pass/Fail in this report are opinions expressed by TA Technology (Shanghai) Co., Ltd. based on interpretations and/or observations of test results. Measurement Uncertainties were not taken into account and are published for informational purposes only.

1. Test Laboratory

1.1. Notes of the test report

This report shall not be reproduced in full or partial, without the written approval of **TA technology (shanghai) co., Ltd.** The results documented in this report apply only to the tested sample, under the conditions and modes of operation as described herein. Measurement Uncertainties were not taken into account and are published for informational purposes only. This report is written to support regulatory compliance of the applicable standards stated above. This report must not be used by the client to claim product certification, approval, or endorsement by any government agencies.

1.2. Test facility

FCC (Designation number: CN1179, Test Firm Registration Number: 446626)

TA Technology (Shanghai) Co., Ltd. has been listed on the US Federal Communications Commission list of test facilities recognized to perform electromagnetic emissions measurements.

A2LA (Certificate Number: 3857.01)

TA Technology (Shanghai) Co., Ltd. has been listed by American Association for Laboratory Accreditation to perform electromagnetic emission measurement.

1.3. Testing Location

Company: TA Technology (Shanghai) Co., Ltd.
Address: Building 3, No.145, Jintang Rd, Pudong Shanghai, P.R.China
City: Shanghai
Post code: 201201
Country: P. R. China
Contact: Xu Kai
Telephone: +86-021-50791141/2/3
Fax: +86-021-50791141/2/3-8000
Website: <http://www.ta-shanghai.com>
E-mail: xukai@ta-shanghai.com

2. General Description of Equipment under Test

2.1. Applicant and Manufacturer Information

Applicant	COOSEA GROUP (HK) COMPANY LIMITED
Applicant address	UNIT 5-6 16/F MULTIFIELD PLAZA 3-7A PRAT AVENUE TSIMSHATSUI KL, HONG KONG, CHINA
Manufacturer	COOSEA GROUP (HK) COMPANY LIMITED
Manufacturer address	UNIT 5-6 16/F MULTIFIELD PLAZA 3-7A PRAT AVENUE TSIMSHATSUI KL, HONG KONG, CHINA

2.2. General information

EUT Description				
Model	SL112A; SL112C			
IMEI	351384680004663			
Hardware Version	1.0			
Software Version	SL112A10010			
Power Supply	Battery / AC adapter			
Antenna Type	PIFA Antenna			
Antenna Connector	A permanently attached antenna (meet with the standard FCC Part 15.203 requirement)			
Test Mode	NFC-A	NFC-B	NFC-F	NFC-V
Modulation Type	ASK	ASK, BPSK	ASK	ASK
Operating Frequency Range(s)	13.56MHz			
Rated Power Supply Voltage	DC 3.85V			
Operating Voltage	Minimum: 3.6V Maximum: 4.4V			
Operating Temperature	Lowest:-10°C Highest: +55°C			
Testing Temperature	Lowest: -20°C Highest: +50°C			
EUT Accessory				
Adapter	Manufacturer: ShenZhen BaiJunDa Electronic Co., Ltd Model: UT-592A-5200ZY			
Battery	Manufacturer: Huizhou Highpower Technology Co., Ltd Model: BL-A50CT			
USB Cable	Manufacturer: Shenzhen Yihuaxing Electronics Co.Ltd.. Model: K342-002			
Auxiliary test equipment				
PC	PC Manufacturer: Microsoft Corporation Model: 1724			

SN: 032324771953

Note: 1. The EUT is sent from the applicant to TA and the information of the EUT is declared by the applicant.
2. The customer claims that SL112A and SL112C are only different in model, and the others are the same. This report only tests SL112A.

3. Applied Standards

According to the specifications of the manufacturer, it must comply with the requirements of the following standards:

Test standards:

FCC CFR47 Part 15C (2022)

ANSI C63.10-2013

Reference standard:

FCC CFR47 Part 2 (2022)

4. Test Configuration

Test Mode

The EUT has been associated with peripherals and configuration operated in a manner tended to maximize its emission characteristics in a typical application.

5. Test Case

5.1. 20dB Bandwidth

Ambient condition

Temperature	Relative humidity	Pressure
23°C ~25°C	45%~50%	101.5kPa

Method of Measurement

The EUT was connected to the spectrum analyzer through an external attenuator (20dB) and a known loss cable. RBW is set to 10 kHz; VBW is set to 3 times the RBW on spectrum analyzer.

Note: Because the measured signal is CW or CW-like adjusting the RBW per C63.10 would not be practical since measured bandwidth will always follow the RBW and the result will be approximately twice the RBW.

Test Setup

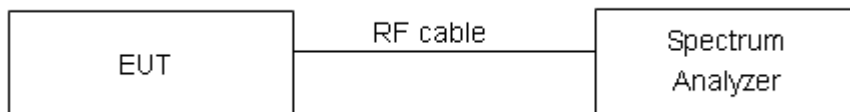

Limits

No specific occupied bandwidth requirements in part 2.1049.

Measurement Uncertainty

The assessed measurement uncertainty to ensure 95% confidence level for the normal distribution is with the coverage factor $k = 2$, $U = 936$ Hz.

Test Results

Refer to the section 6.1 of this report for test data.

5.2. Frequency Stability

Ambient condition

Temperature	Relative humidity
21°C ~25°C	40%~60%

Method of Measurement

1. Frequency Stability (Temperature Variation)

The temperature inside the climate chamber is varied from -20°C to +50°C in 10°C step size,

(1) With all power removed, the temperature was decreased to 0°C and permitted to stabilize for three hours.

(2) Measure the carrier frequency with the test equipment in a “call mode”. These measurements should be made within 1 minute of powering up the mobile station, to prevent significant self warming.

(3) Repeat the above measurements at 10°C increments from -20°C to +50°C. Allow at least 1.5 hours at each temperature, un-powered, before making measurements.

2. Frequency Stability (Voltage Variation)

The frequency stability shall be measured with variation of primary supply voltage as follows:

Primary Supply Voltage: The primary supply voltage is varied from 85% to 115% of the nominal value for non hand-carried battery and AC powered equipment. For hand-carried, battery-powered equipment, primary supply voltage is reduced to the battery operating end point which shall be specified by the manufacturer.

This transceiver is specified to operate with an input voltage of between 3.6 V and 4.4 V, with a nominal voltage of 3.85V.

Test setup

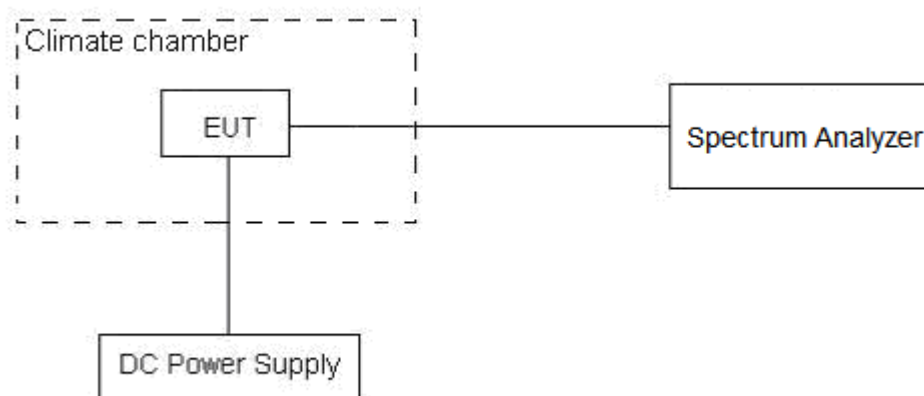

Limits

Rule Part 15.225 (e) The frequency tolerance of the carrier signal shall be maintained within $\pm 0.01\%$ of the operating frequency over a temperature variation of -20 degrees to $+ 50$ degrees C at normal supply voltage, and for a variation in the primary supply voltage from 85% to 115% of the rated supply voltage at a temperature of 20 degrees C. For battery operated equipment, the equipment tests shall be performed using a new battery.

Measurement Uncertainty

The assessed measurement uncertainty to ensure 99.75% confidence level for the normal distribution is with the coverage factor $k = 3$, $U = 0.01\text{ppm}$.

Test Results

Refer to the section 6.2 of this report for test data.

5.3. Radiates Emission

Ambient condition

Temperature	Relative humidity	Pressure
23°C ~25°C	45%~50%	102.5kPa

Method of Measurement

The test set-up was made in accordance to the general provisions of ANSI C63.10. The Equipment Under Test (EUT) was set up on a non-conductive table in the semi-anechoic chamber. The test was performed at the distance of 3 m between the EUT and the receiving antenna. The radiated emissions measurements were made in a typical installation configuration.

Sweep the whole frequency band through the range from 9 kHz to the 10th harmonic of the carrier, and the emissions less than 20 dB below the permissible value are reported.

During the test, below 30MHz, the center of the loop shall be 1 meters; above 30MHz, the height of receive antenna shall be moved from 1 to 4 meters, and the antenna shall be performed under horizontal and vertical polarization. The turntable shall be rotated from 0 to 360 degrees for detecting the maximum of radiated spurious signal level. The measurements shall be repeated with orthogonal polarization of the test antenna. The data of cable loss and antenna factor has been calibrated in full testing frequency range before the testing.

Set the spectrum analyzer in the following:

Out-of-band

Below30MHz

RBW=9KHz, VBW=30KHz, detector=peak;

Above 30MHz,

RBW=100KHz, VBW=300KHz, Detector=peak

In-band

RBW=9KHz, VBW=30KHz, detector=peak;

The field strength of spurious emission was measured in the following position: EUT stand-up position (Z axis), lie-down position (X, Y axis). The worst emission was found in lie-down position (X axis) and the loop antenna is vertical, the other antennas are vertical and horizontal.

Test setup

9KHz~ 30MHz

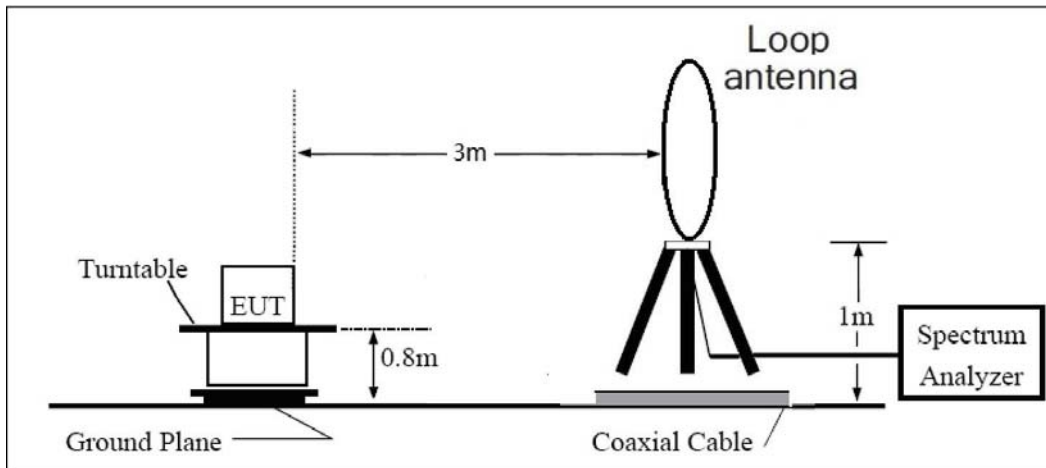

30MHz~ 1GHz

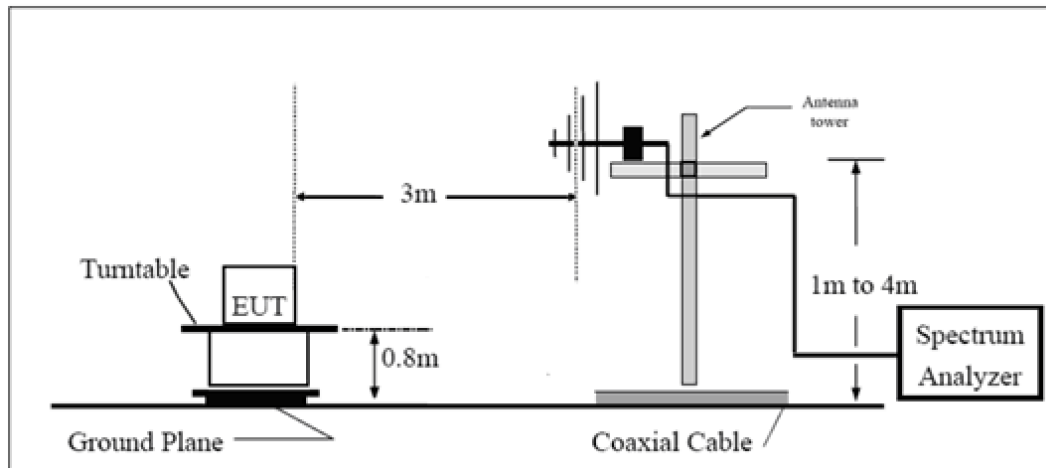

Above 1GHz

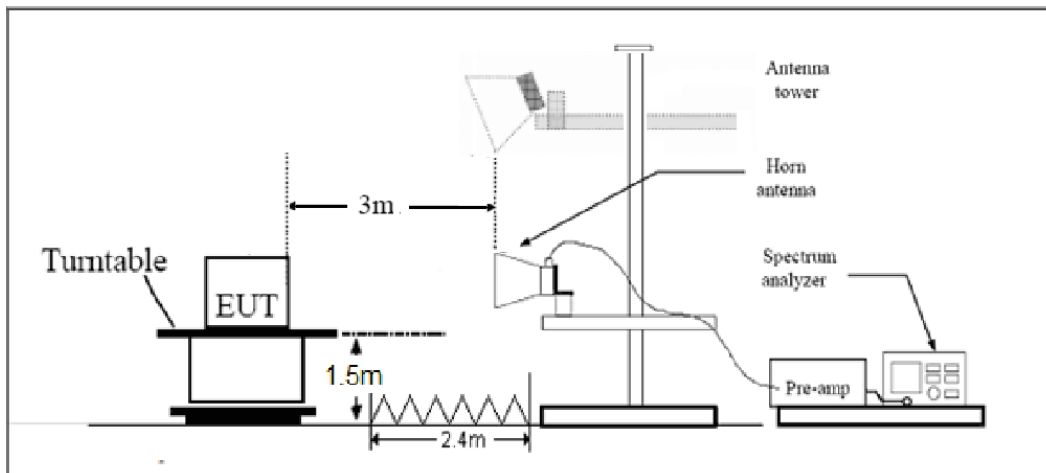

Note: Area side:2.4mX3.6m

Limits

Clause 15.225(a) the field strength of any emissions within the band 13.553-13.567 MHz shall not exceed 15,848 microvolts/meter at 30 meters.

Clause 15.225(b) within the bands 13.410-13.553 MHz and 13.567-13.710 MHz, the field strength of any emissions shall not exceed 334 microvolts/meter at 30 meters.

Clause 15.225(c) within the bands 13.110-13.410 MHz and 13.710-14.010 MHz the field strength of any emissions shall not exceed 106 microvolts/meter at 30 meters.

Clause 15.225(d) The field strength of any emissions appearing outside of the 13.110-14.010 MHz band shall not exceed the general radiated emission limits in §15.209.

§15.209 (a) Except as provided elsewhere in this subpart, the emissions from an intentional radiator shall not exceed the field strength levels specified in the following table:

Frequency of emission (MHz)	Field strength(μV/m)	Field strength(dBμV/m)
0.009–0.490	2400/F(kHz)	128.519dBμV/m -93.8ddBμV/m
0.490–1.705	24000/F(kHz)	73.8dB dBμV/m -62.969dBμV/m
1.705–30.0	30	69.5 dBμV/m
30-88	100	40 dBμV/m
88-216	150	43.5 dBμV/m
216-960	200	46 dBμV/m
Above960	500	54 dBμV/m

When using other measurement distance, according to the standard C63.10, If that point is closer to the EUT than $\lambda/2\pi$ and the limit distance is greater than $\lambda/2\pi$, the data was extrapolated to the specified measurement distance of 30m using extrapolation factor as specified in §6.4.4.2. Extrapolation Factor = $40\log(d \text{ near filed}/ d \text{ measure}) + 20\log(d \text{ limit} / d \text{ near filed})$

**Except as provided in paragraph (g), fundamental emissions from intentional radiators operating under this section shall not be located in the frequency bands 54-72 MHz, 76-88 MHz, 174-216 MHz or 470-806 MHz. However, operation within these frequency bands is permitted under other sections of this part, e.g., §§15.231 and 15.241.

§15.209 (b) In the emission table above, the tighter limit applies at the band edges.

§15.209 (d) The emission limits shown in the above table are based on measurements employing a CISPR quasi-peak detector except for the frequency bands 9-90 kHz, 110-490 kHz and above 1000 MHz. Radiated emission limits in these three bands are based on measurements employing an average detector.

Measurement Uncertainty

The assessed measurement uncertainty to ensure 95% confidence level for the normal distribution is with the coverage factor $k = 1.96$.

Frequency	Uncertainty
9KHz-30MHz	3.55 dB
30MHz-200MHz	4.02 dB
200MHz-1GHz	3.28 dB
Above 1GHz	3.70 dB

Test Results

Refer to the section 6.3 of this report for test data.

5.4. Conducted Emission

Ambient condition

Temperature	Relative humidity	Pressure
23°C ~25°C	45%~50%	101.5kPa

Methods of Measurement

The EUT is placed on a non-metallic table of 80cm height above the horizontal metal reference ground plane. During the test, the EUT was operating in its typical mode. The test method is according to ANSI C63.10. Connect the AC power line of the EUT to the L.I.S.N. Use EMI receiver to detect the average and Quasi-peak value. RBW is set to 9 kHz, VBW is set to 30kHz.

The measurement result should include both L line and N line.

The test is in transmitting mode.

Test Setup

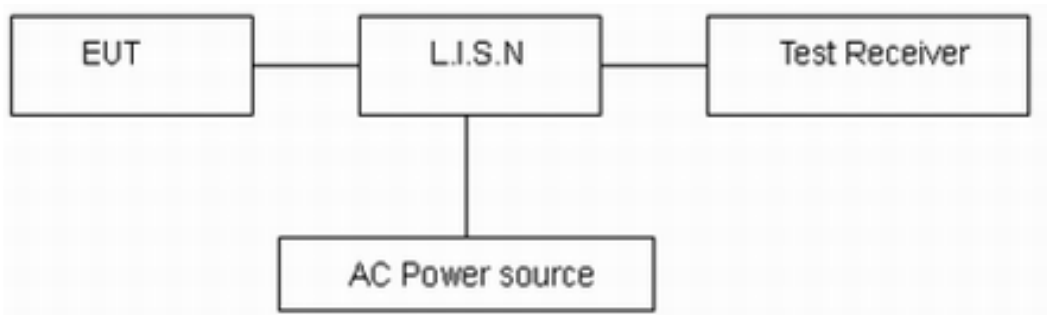

Note: AC Power source is used to change the voltage 110V/60Hz.

Limits

§15.207 (a) Except as shown in paragraphs (b) and (c) of this section, for an intentional radiator that is designed to be connected to the public utility (AC) power line, the radio frequency voltage that is conducted back onto the AC power line on any frequency or frequencies, within the band 150 kHz to 30 MHz, shall not exceed the limits in the following table, as measured using a 50 μH/50 ohms line impedance stabilization network (LISN). Compliance with the provisions of this paragraph shall be based on the measurement of the radio frequency voltage between each power line and ground at the power terminal. The lower limit applies at the boundary between the frequency ranges.

Frequency (MHz)	Conducted Limits(dBμV)	
	Quasi-peak	Average
0.15 - 0.5	66 to 56 *	56 to 46 *
0.5 - 5	56	46
5 - 30	60	50

*: Decreases with the logarithm of the frequency.

Measurement Uncertainty

The assessed measurement uncertainty to ensure 95% confidence level for the normal distribution is with the coverage factor $k = 1.96$, $U = 2.69$ dB.

Test Results

Refer to the section 6.4 of this report for test data.

6. Test Results

6.1. 20dB Bandwidth

NFC-A

Carrier frequency (MHz)	99% Bandwidth (kHz)	20dB Bandwidth (kHz)	Conclusion
13.56MHz	23.023	27.15	PASS

NFC-B

Carrier frequency (MHz)	99% Bandwidth (kHz)	20dB Bandwidth (kHz)	Conclusion
13.56MHz	23.024	27.15	PASS

NFC-F

Carrier frequency (MHz)	99% Bandwidth (kHz)	20dB Bandwidth (kHz)	Conclusion
13.56MHz	23.033	27.17	PASS

NFC-V

Carrier frequency (MHz)	99% Bandwidth (kHz)	20dB Bandwidth (kHz)	Conclusion
13.56MHz	23.033	27.17	PASS

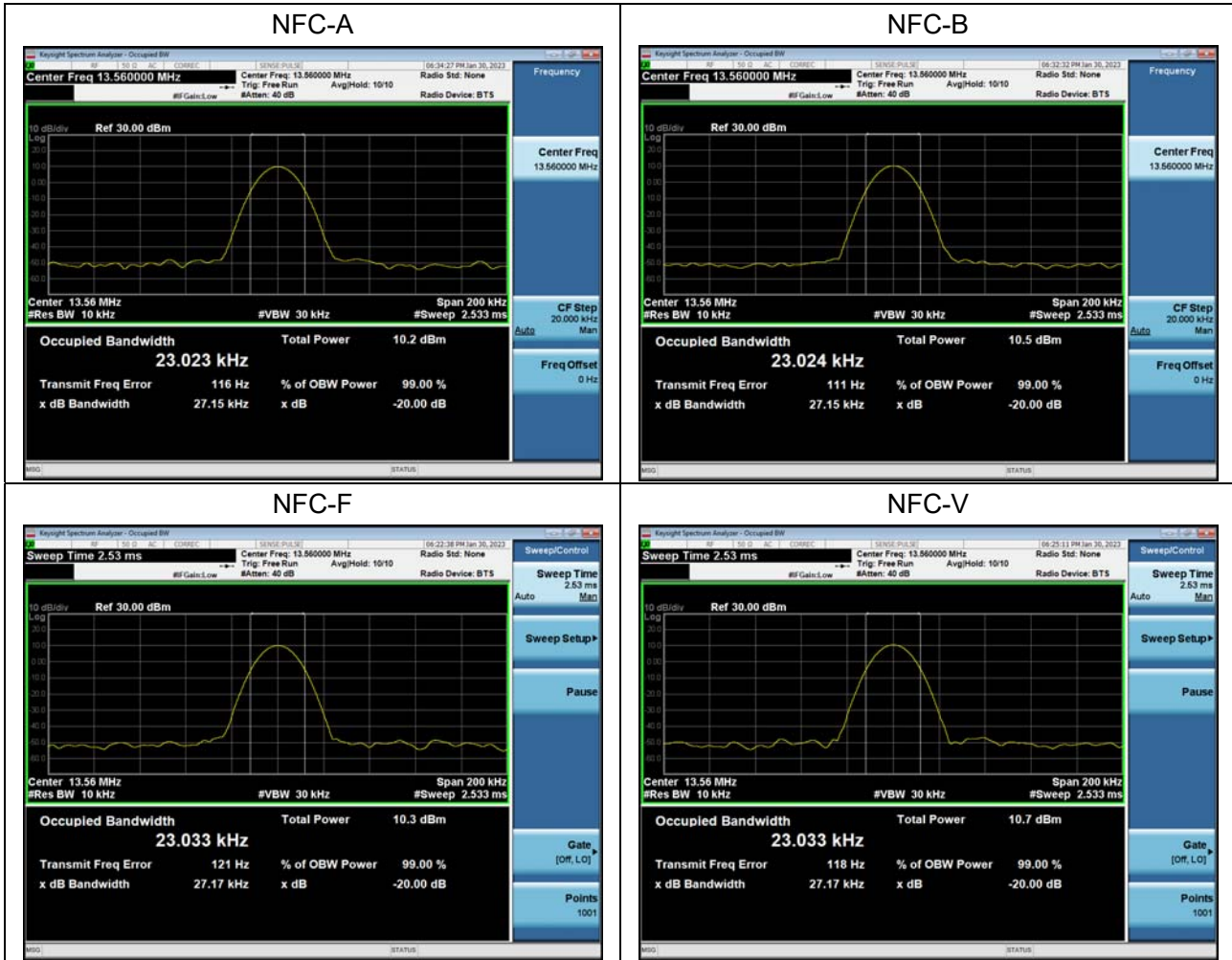

6.2. Frequency Stability

NFC-A

Test status	Frequency				Tolerance (MHz)			
	13.56MHz							
	1min	2min	5min	10min	1min	2min	5min	10min
-20°C/3.85V	13.559342	13.559351	13.559333	13.559346	0.000658	0.000649	0.000667	0.000654
-10°C/3.85V	13.559340	13.559348	13.559330	13.559339	0.000660	0.000652	0.000670	0.000661
0°C/3.85V	13.559336	13.559344	13.559320	13.559329	0.000664	0.000656	0.000680	0.000671
10°C/3.85V	13.559331	13.559340	13.559320	13.559327	0.000669	0.000660	0.000680	0.000673
20°C/3.85V	13.559328	13.559332	13.559311	13.559322	0.000672	0.000668	0.000689	0.000678
30°C/3.85V	13.559327	13.559323	13.559307	13.559314	0.000673	0.000677	0.000693	0.000686
40°C/3.85V	13.559322	13.559318	13.559300	13.559308	0.000678	0.000682	0.000700	0.000692
50°C/3.85V	13.559314	13.559317	13.559299	13.559302	0.000686	0.000683	0.000701	0.000698
25°C/3.60V	13.559305	13.559307	13.559293	13.559302	0.000695	0.000693	0.000707	0.000698
25°C/4.40V	13.559301	13.559306	13.559288	13.559294	0.000699	0.000694	0.000712	0.000706

Test status	Tolerance (%)				Limit (%)	Conclusion
	1min	2min	5min	10min		
-20°C/3.85V	0.004853	0.004786	0.004919	0.004823	0.01	PASS
-10°C/3.85V	0.004867	0.004808	0.004941	0.004875	0.01	PASS
0°C/3.85V	0.004897	0.004838	0.005015	0.004948	0.01	PASS
10°C/3.85V	0.004934	0.004867	0.005015	0.004963	0.01	PASS
20°C/3.85V	0.004956	0.004926	0.005081	0.005000	0.01	PASS
30°C/3.85V	0.004963	0.004993	0.005111	0.005059	0.01	PASS
40°C/3.85V	0.005000	0.005029	0.005162	0.005103	0.01	PASS
50°C/3.85V	0.005059	0.005037	0.005170	0.005147	0.01	PASS
25°C/3.60V	0.005125	0.005111	0.005214	0.005147	0.01	PASS
25°C/4.40V	0.005155	0.005118	0.005251	0.005206	0.01	PASS

NFC-B

Test status	Frequency				Tolerance (MHz)			
	13.56MHz							
	1min	2min	5min	10min	1min	2min	5min	10min
-20°C/3.85V	13.559346	13.559345	13.559340	13.559351	0.000654	0.000655	0.000660	0.000649
-10°C/3.85V	13.559337	13.559335	13.559339	13.559342	0.000663	0.000665	0.000661	0.000658
0°C/3.85V	13.559337	13.559332	13.559336	13.559337	0.000663	0.000668	0.000664	0.000663
10°C/3.85V	13.559329	13.559332	13.559332	13.559333	0.000671	0.000668	0.000668	0.000667
20°C/3.85V	13.559320	13.559326	13.559331	13.559330	0.000680	0.000674	0.000669	0.000670
30°C/3.85V	13.559319	13.559323	13.559328	13.559322	0.000681	0.000677	0.000672	0.000678
40°C/3.85V	13.559318	13.559315	13.559325	13.559319	0.000682	0.000685	0.000675	0.000681
50°C/3.85V	13.559317	13.559313	13.559317	13.559310	0.000683	0.000687	0.000683	0.000690
25°C/3.60V	13.559311	13.559309	13.559310	13.559301	0.000689	0.000691	0.000690	0.000699
25°C/4.40V	13.559304	13.559307	13.559302	13.559298	0.000696	0.000693	0.000698	0.000702

Test status	Tolerance (%)				Limit(%)	Conclusion
	1min	2min	5min	10min		
-20°C/3.85V	0.004823	0.004830	0.004867	0.004786	0.01	PASS
-10°C/3.85V	0.004889	0.004904	0.004875	0.004853	0.01	PASS
0°C/3.85V	0.004889	0.004926	0.004897	0.004889	0.01	PASS
10°C/3.85V	0.004948	0.004926	0.004926	0.004919	0.01	PASS
20°C/3.85V	0.005015	0.004971	0.004934	0.004941	0.01	PASS
30°C/3.85V	0.005022	0.004993	0.004956	0.005000	0.01	PASS
40°C/3.85V	0.005029	0.005052	0.004978	0.005022	0.01	PASS
50°C/3.85V	0.005037	0.005066	0.005037	0.005088	0.01	PASS
25°C/3.60V	0.005081	0.005096	0.005088	0.005155	0.01	PASS
25°C/4.40V	0.005133	0.005111	0.005147	0.005177	0.01	PASS

NFC-F

Test status	Frequency				Tolerance (MHz)			
	13.56MHz							
	1min	2min	5min	10min	1min	2min	5min	10min
-20°C/3.85V	13.559351	13.559335	13.559334	13.559336	0.000649	0.000665	0.000666	0.000664
-10°C/3.85V	13.559349	13.559325	13.559329	13.559331	0.000651	0.000675	0.000671	0.000669
0°C/3.85V	13.559343	13.559320	13.559325	13.559322	0.000657	0.000680	0.000675	0.000678
10°C/3.85V	13.559338	13.559315	13.559323	13.559322	0.000662	0.000685	0.000677	0.000678
20°C/3.85V	13.559336	13.559315	13.559314	13.559322	0.000664	0.000685	0.000686	0.000678
30°C/3.85V	13.559332	13.559309	13.559310	13.559321	0.000668	0.000691	0.000690	0.000679
40°C/3.85V	13.559325	13.559302	13.559301	13.559316	0.000675	0.000698	0.000699	0.000684
50°C/3.85V	13.559322	13.559297	13.559298	13.559309	0.000678	0.000703	0.000702	0.000691
25°C/3.60V	13.559317	13.559295	13.559297	13.559308	0.000683	0.000705	0.000703	0.000692
25°C/4.40V	13.559314	13.559286	13.559290	13.559299	0.000686	0.000714	0.000710	0.000701

Test status	Tolerance (%)				Limit(%)	Conclusion
	1min	2min	5min	10min		
-20°C/3.85V	0.004786	0.004904	0.004912	0.004897	0.01	PASS
-10°C/3.85V	0.004801	0.004978	0.004948	0.004934	0.01	PASS
0°C/3.85V	0.004845	0.005015	0.004978	0.005000	0.01	PASS
10°C/3.85V	0.004882	0.005052	0.004993	0.005000	0.01	PASS
20°C/3.85V	0.004897	0.005052	0.005059	0.005000	0.01	PASS
30°C/3.85V	0.004926	0.005096	0.005088	0.005007	0.01	PASS
40°C/3.85V	0.004978	0.005147	0.005155	0.005044	0.01	PASS
50°C/3.85V	0.005000	0.005184	0.005177	0.005096	0.01	PASS
25°C/3.60V	0.005037	0.005199	0.005184	0.005103	0.01	PASS
25°C/4.40V	0.005059	0.005265	0.005236	0.005170	0.01	PASS

NFC-V

Test status	Frequency				Tolerance (MHz)			
	13.56MHz							
	1min	2min	5min	10min	1min	2min	5min	10min
-20°C/3.85V	13.559347	13.559345	13.559347	13.559352	0.000653	0.000655	0.000653	0.000648
-10°C/3.85V	13.559340	13.559337	13.559341	13.559344	0.000660	0.000663	0.000659	0.000656
0°C/3.85V	13.559339	13.559329	13.559336	13.559338	0.000661	0.000671	0.000664	0.000662
10°C/3.85V	13.559338	13.559324	13.559334	13.559331	0.000662	0.000676	0.000666	0.000669
20°C/3.85V	13.559335	13.559318	13.559325	13.559329	0.000665	0.000682	0.000675	0.000671
30°C/3.85V	13.559328	13.559317	13.559324	13.559326	0.000672	0.000683	0.000676	0.000674
40°C/3.85V	13.559323	13.559313	13.559317	13.559326	0.000677	0.000687	0.000683	0.000674
50°C/3.85V	13.559322	13.559304	13.559308	13.559325	0.000678	0.000696	0.000692	0.000675
25°C/3.60V	13.559317	13.559295	13.559299	13.559323	0.000683	0.000705	0.000701	0.000677
25°C/4.40V	13.559307	13.559288	13.559292	13.559319	0.000693	0.000712	0.000708	0.000681

Test status	Tolerance (%)				Limit(%)	Conclusion
	1min	2min	5min	10min		
-20°C/3.85V	0.004816	0.004830	0.004816	0.004779	0.01	PASS
-10°C/3.85V	0.004867	0.004889	0.004860	0.004838	0.01	PASS
0°C/3.85V	0.004875	0.004948	0.004897	0.004882	0.01	PASS
10°C/3.85V	0.004882	0.004985	0.004912	0.004934	0.01	PASS
20°C/3.85V	0.004904	0.005029	0.004978	0.004948	0.01	PASS
30°C/3.85V	0.004956	0.005037	0.004985	0.004971	0.01	PASS
40°C/3.85V	0.004993	0.005066	0.005037	0.004971	0.01	PASS
50°C/3.85V	0.005000	0.005133	0.005103	0.004978	0.01	PASS
25°C/3.60V	0.005037	0.005199	0.005170	0.004993	0.01	PASS
25°C/4.40V	0.005111	0.005251	0.005221	0.005022	0.01	PASS

6.3. Radiates Emission

The test is in transmitting all mode, NFC-A was selected as the worst condition. The test data of the worst-case condition was recorded in this report.

A symbol (dB_{μV/m}) in the test plot below means (dB μ V/m)

In-band

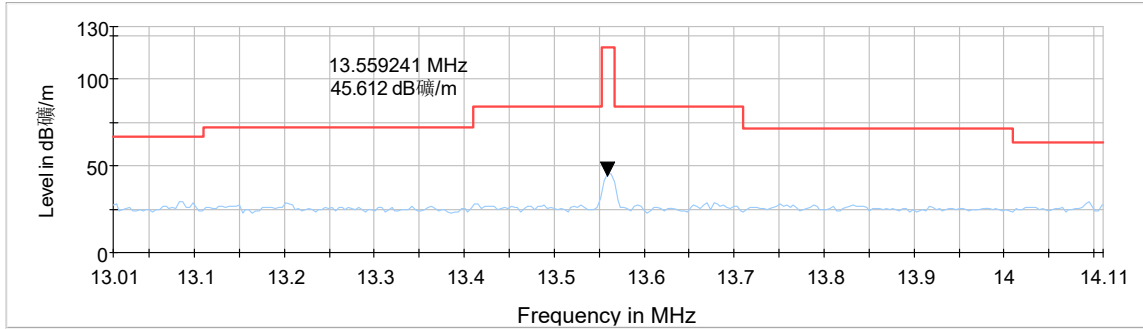

Radiates Emission from 13.01MHz to 14.11MHz

Note: This graph displays the maximum values of horizontal and vertical by software

Out-of-band

The test is in transmitting all mode, NFC-A was selected as the worst condition. The test data of the worst-case condition was recorded in this report.

The following graphs display the maximum values of horizontal and vertical by software.

For above 1GHz, Blue trace uses the peak detection, Green trace uses the average detection.

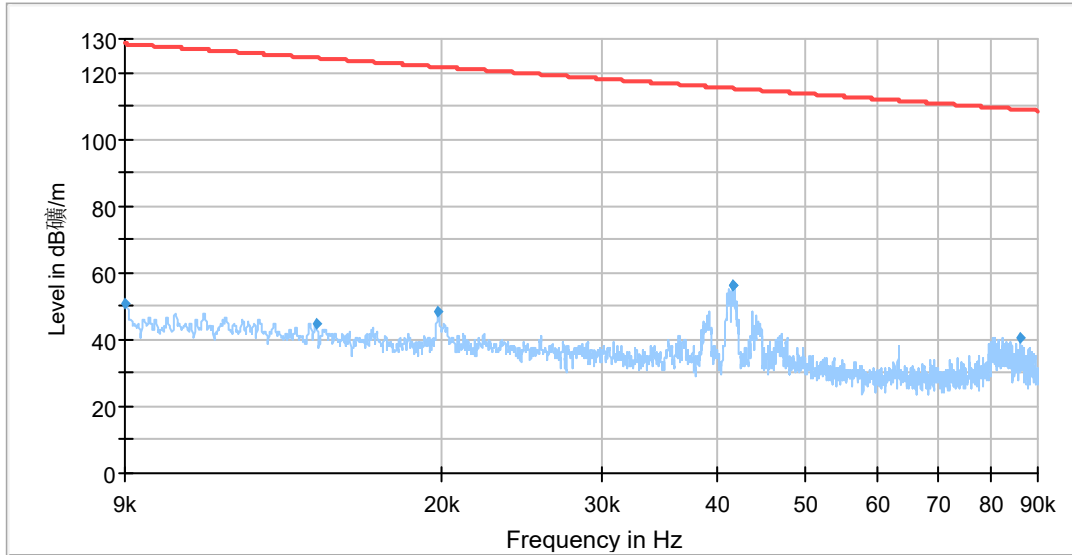

Radiates Emission from 9kHz to 90kHz

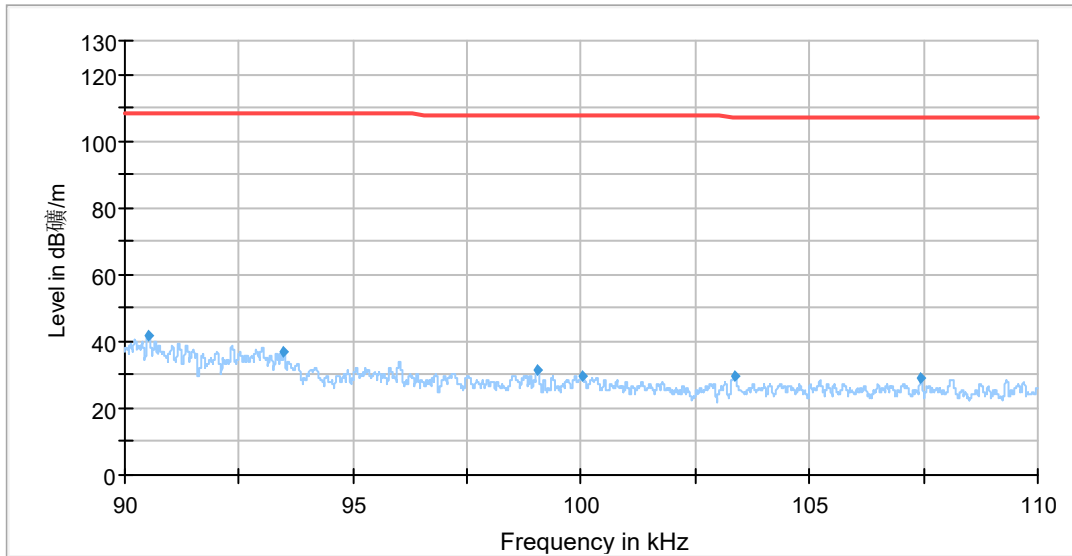

Radiates Emission from 90kHz to 110kHz

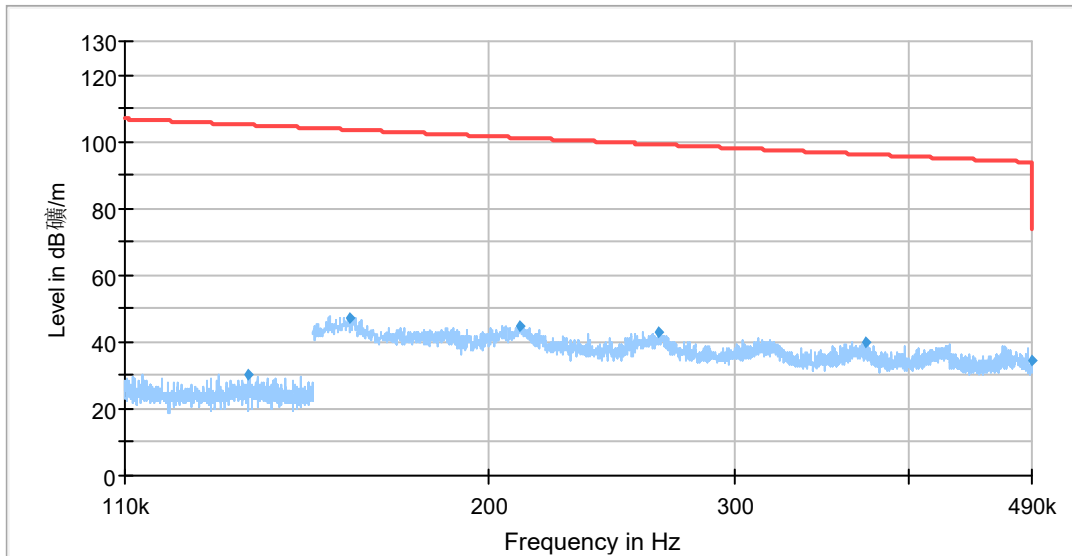

Radiates Emission from 110kHz to 490kHz

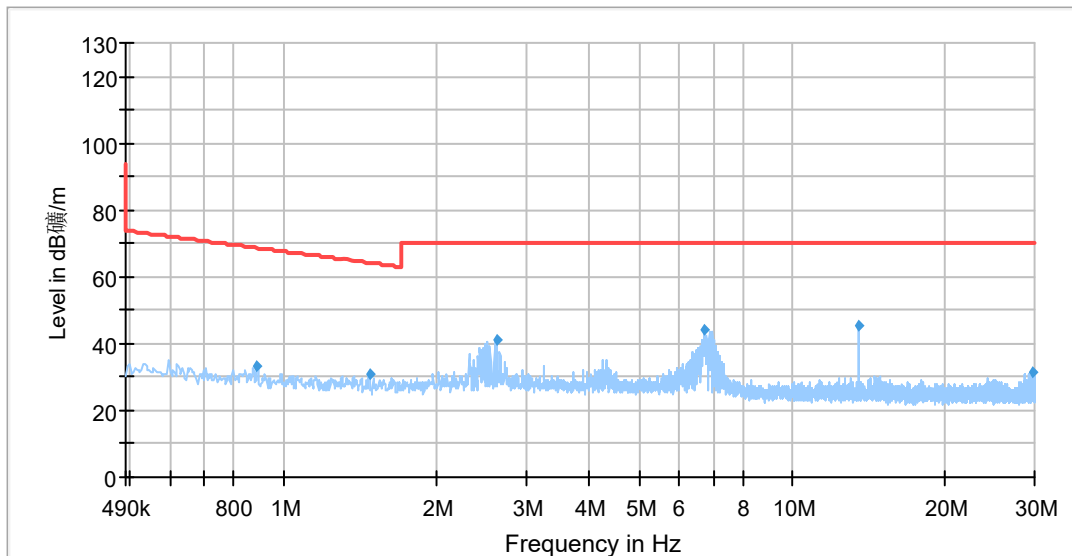

Radiates Emission from 490kHz to 30MHz

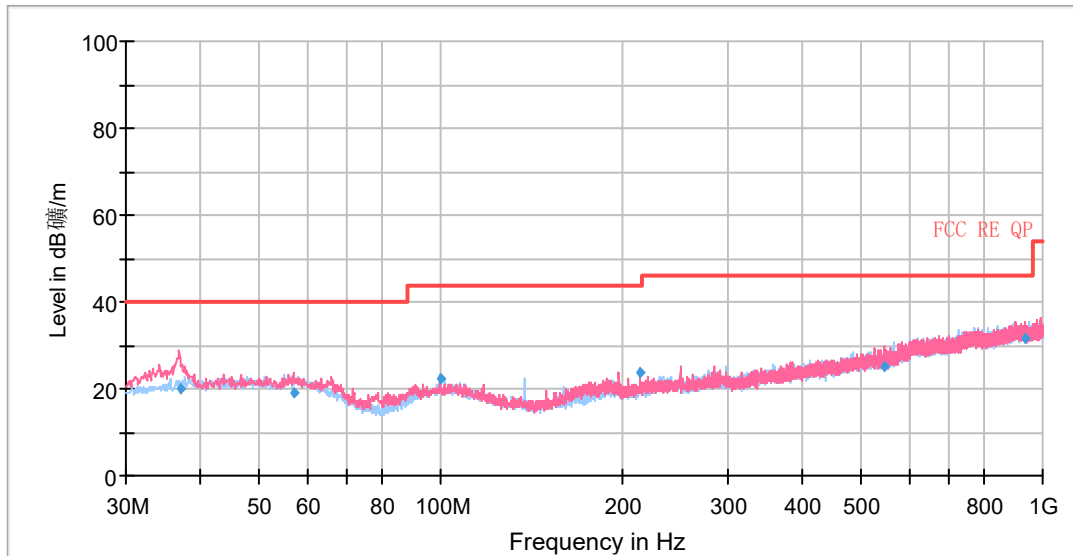

Radiates Emission from 30MHz to 1GHz

Note: This graph displays the maximum values of horizontal and vertical by software

Frequency (MHz)	Quasi-Peak (dBµV/m)	Limit (dBµV/m)	Margin (dB)	Height (cm)	Polarization	Azimuth (deg)	Correct Factor (dB)
36.87	20.21	40.00	19.79	100.0	V	202.00	14
57.28	19.05	40.00	20.95	101.0	V	168.00	15
100.16	22.27	43.50	21.23	175.0	V	151.00	13
214.50	23.72	43.50	19.78	218.0	V	275.00	13
543.98	25.08	46.00	20.92	216.0	V	133.00	20
933.04	31.75	46.00	14.25	196.0	V	6.00	26

Remark: 1. Correction Factor = Antenna factor + Insertion loss (cable loss + amplifier gain)

2. Margin = Limit – Quasi-Peak

6.4. Conducted Emission

The test is in transmitting all mode, NFC-A was selected as the worst condition. The test data of the worst-case condition was recorded in this report.

Following plots, Blue trace uses the peak detection and Green trace uses the average detection.

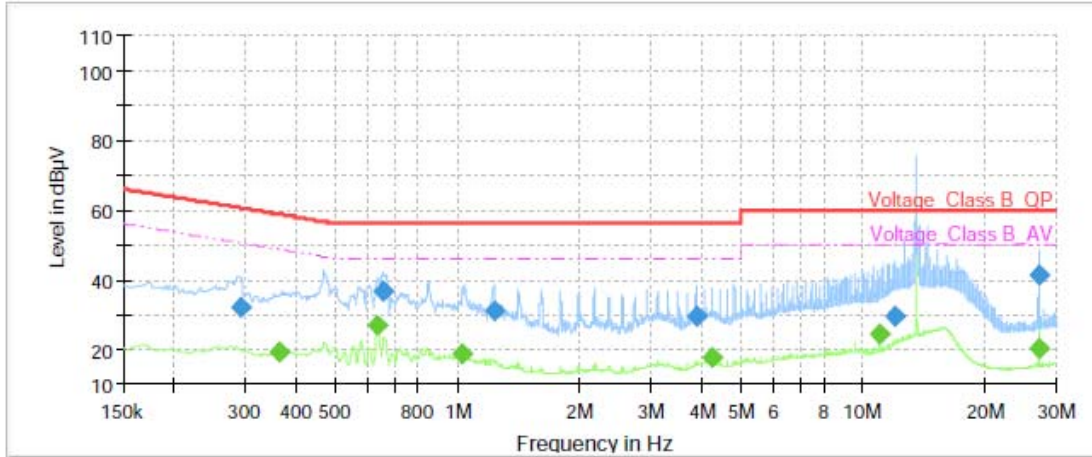

Note: The signal beyond the limit is carrier.

Frequency (MHz)	QuasiPeak (dBµV)	Average (dBµV)	Limit (dBµV)	Margin (dB)	Meas. Time (ms)	Bandwidth (kHz)	Line	Filter	Corr. (dB)
0.29	32.07	---	60.47	28.40	1000.0	9.000	L1	ON	20.9
0.36	---	19.09	48.69	29.60	1000.0	9.000	L1	ON	20.8
0.64	---	27.17	46.00	18.83	1000.0	9.000	L1	ON	20.5
0.66	36.55	---	56.00	19.45	1000.0	9.000	L1	ON	20.4
1.03	---	18.77	46.00	27.23	1000.0	9.000	L1	ON	19.9
1.23	31.23	---	56.00	24.77	1000.0	9.000	L1	ON	19.8
3.87	29.59	---	56.00	26.41	1000.0	9.000	L1	ON	19.2
4.25	---	17.44	46.00	28.56	1000.0	9.000	L1	ON	19.2
11.02	---	24.60	50.00	25.40	1000.0	9.000	L1	ON	19.3
12.00	29.33	---	60.00	30.67	1000.0	9.000	L1	ON	19.3
27.12	---	20.38	50.00	29.62	1000.0	9.000	L1	ON	20.0
27.12	41.22	---	60.00	18.78	1000.0	9.000	L1	ON	20.0

Remark: Correct factor=cable loss + LISN factor

L line Conducted Emission from 150 KHz to 30 MHz

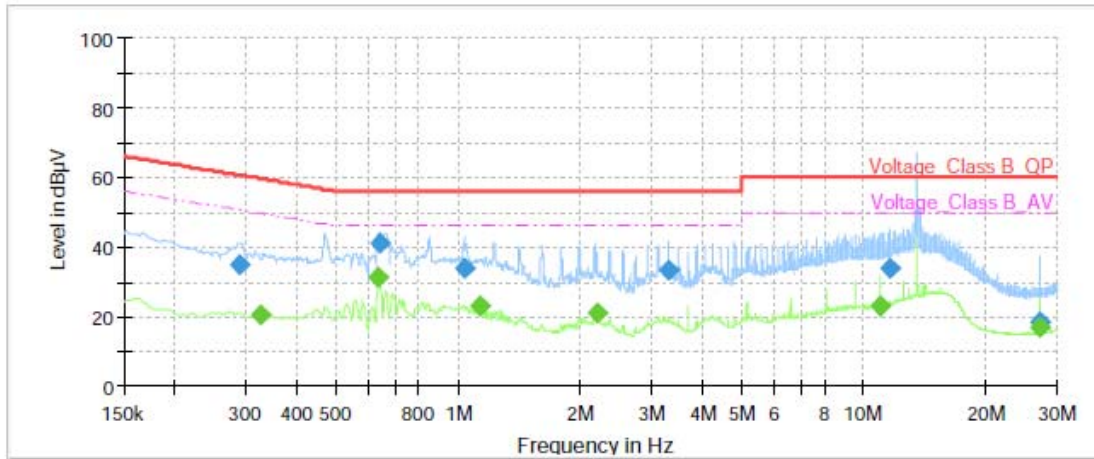

Note: The signal beyond the limit is carrier.

Frequency (MHz)	QuasiPeak (dBµV)	Average (dBµV)	Limit (dBµV)	Margin (dB)	Meas. Time (ms)	Bandwidth (kHz)	Line	Filter	Corr. (dB)
0.29	34.88	---	60.54	25.66	1000.0	9.000	N	ON	20.9
0.33	---	20.59	49.57	28.98	1000.0	9.000	N	ON	20.9
0.64	---	31.41	46.00	14.59	1000.0	9.000	N	ON	20.5
0.64	41.21	---	56.00	14.79	1000.0	9.000	N	ON	20.5
1.03	33.89	---	56.00	22.11	1000.0	9.000	N	ON	20.0
1.14	---	22.83	46.00	23.17	1000.0	9.000	N	ON	19.9
2.20	---	21.03	46.00	24.97	1000.0	9.000	N	ON	19.4
3.31	33.22	---	56.00	22.78	1000.0	9.000	N	ON	19.3
11.02	---	22.83	50.00	27.17	1000.0	9.000	N	ON	19.4
11.61	33.98	---	60.00	26.02	1000.0	9.000	N	ON	19.4
27.12	---	17.14	50.00	32.86	1000.0	9.000	N	ON	20.1
27.12	18.29	---	60.00	41.71	1000.0	9.000	N	ON	20.1

Remark: Correct factor=cable loss + LISN factor

N line Conducted Emission from 150 KHz to 30 MHz

7. Main Test Instruments

Name	Manufacturer	Type	Serial Number	Calibration Date	Expiration Time
Spectrum Analyzer	KEYSIGHT	N9020A	MY51330870	2022-05-14	2023-05-13
DC Power Supply	UNI-T	UTP1306S+	2205D0517232	2022-12-10	2023-12-09
Radiated Emission					
EMI Test Receiver	R&S	ESR	102389	2022-05-25	2023-05-24
Signal Analyzer	R&S	FSV40	101186	2022-05-14	2023-05-13
Loop Antenna	SCHWARZBECK	FMZB1519	1519-047	2020-04-02	2023-04-01
TRILOG Broadband Antenna	SCHWARZBECK	VULB 9163	1023	2020-05-05	2023-05-04
Software	R&S	EMC32	9.26.01	/	/
Conducted Emission					
Artificial main network	R&S	ENV216	102191	2022-12-13	2024-12-09
EMI Test Receiver	R&S	ESR	101667	2022-05-25	2023-05-24
Software	R&S	EMC32	10.35.10	/	/

*****END OF REPORT *****

ANNEX A: The EUT Appearance

The EUT Appearance is submitted separately.

ANNEX B: Test Setup Photos

The Test Setup Photos is submitted separately.