

FCC CFR47 PART 22H, 24E, 27 CERTIFICATION TEST REPORT

FCC ID: 2A27O-AT1012U

Product: Tablet PC

Trade Mark: Azeyou

Model Number: AT1012U

Family Model: M17QF1U-T310, AT1012E, AT1012Q

Report No.: S21091400802006

Prepared for

Dongguan Lianzhou Electronic Technology Co., Ltd.

Building 1, No. 10, Feng Gang Technology Road, Feng Gang Town, DongGuan
City, GuangDong Province, China

Prepared by

Shenzhen NTEK Testing Technology Co., Ltd.

1/F, Building E, Fenda Science Park, Sanwei Community,
Xixiang Street Bao'an District, Shenzhen 518126 P.R. China

Tel. 400-800-6106, 0755-2320 0050, 0755-2320 0090

Website: <http://www.ntek.org.cn>

TEST RESULT CERTIFICATION

Applicant's name	Dongguan Lianzhou Electronic Technology Co., Ltd.
Address.....	Building 1, No. 10, Feng Gang Technology Road, Feng Gang Town, DongGuan City, GuangDong Province, China
Manufacturer's Name	Dongguan Lianzhou Electronic Technology Co., Ltd.
Address.....	Building 1, No. 10, Feng Gang Technology Road, Feng Gang Town, DongGuan City, GuangDong Province, China
Product name.....	Tablet PC
Model and/or type reference ..	AT1012U
Family Model:	M17QF1U-T310, AT1012E, AT1012Q
Standards	FCC CFR 47 Part 22H, Part 24E, Part 27
Test procedure	ANSI C63.26:2015 ANSI/TIA-603-E-2016

This device described above has been tested by NTEK, and the test results show that the equipment under test (EUT) is in compliance with the FCC requirements. And it is applicable only to the tested sample identified in the report.

This report shall not be reproduced except in full, without the written approval of NTEK, this document may be altered or revised by NTEK, personal only, and shall be noted in the revision of the document.

Date of Test	
Date (s) of performance of tests.....	Sep 15, 2021 ~ Oct 19, 2021
Date of Issue	Oct 22, 2021
Test Result	Pass

Testing Engineer : 

 (Allen Liu)

Authorized Signatory : 

 (Alex Li)

TABLE OF CONTENTS

1. GENERAL INFORMATION.....	6
1.1 PRODUCT DESCRIPTION	6
1.2 RELATED SUBMITTAL(S) / GRANT (S).....	7
1.3 TEST METHODOLOGY	7
1.4 TEST FACILITY	7
MEASUREMENT UNCERTAINTY	7
1.5 SPECIAL ACCESSORIES	7
1.6 WORST-CASE CONFIGURATION AND MODE.....	8
1.6 SUMMARY OF TEST RESULTS.....	8
2. SYSTEM TEST CONFIGURATION	10
2.1 EUT CONFIGURATION	10
2.2 EUT EXERCISE.....	10
2.3 CONFIGURATION OF EUT SYSTEM	10
2.4 TEST SETUP	11
3. TEST AND MEASUREMENT EQUIPMENT	12
4. OUTPUT POWER.....	14
4.1 OUTPUT POWER MEASUREMENT	14
6. BANDEDGE AND EMISSION MASK.....	17
7. OUT OF BAND EMISSIONS	18
7.1 MEASUREMENT METHOD	19
8. RADIATED MEASUREMENT	20
8.1. RADIATED POWER (ERP & EIRP)	20
8.2 LTE BAND 2	21
8.3 LTE BAND 4	25
8.4 LTE BAND 5	29

8.5 LTE BAND 7	31
8.6 LTE BAND 17	33
9. SPURIOUS RADIATION EMISSION	35
9.1 LTE BAND 2	37
9.2 LTE BAND 4	39
9.3 LTE BAND 5	41
9.4 LTE BAND 7	43
9.5 LTE BAND 17	45
10. FREQUENCY STABILITY	47
10.1 LTE BAND 2	48
10.2 LTE BAND 4	50
10.3 LTE BAND 5	52
10.4 LTE BAND 7	54
10.5 LTE BAND 17	56
11. PEAK-TO-AVERAGE RATIO	58
11.1 Description of the PAR Measurement	58
11.2 Measuring Instruments	58
11.3 Test Procedures	58
11.4 Test Setup	58

1. GENERAL INFORMATION

1.1 PRODUCT DESCRIPTION

A major technical description of EUT is described as following:

Product Designation:	Tablet PC
Trade Mark	Azeyou
Model Name	AT1012U
Family Model	M17QF1U-T310, AT1012E, AT1012Q
Model Difference	All models are the same circuit and RF module, except the Model name.
FCC ID:	2A27O-AT1012U
Frequency Bands:	U.S. Bands: <input checked="" type="checkbox"/> LTE FDD Band 2, 4, 5, 7, 17
Frequency Range:	LTE FDD Band 2 Uplink: 1850MHz-1910MHz, Downlink: 1930MHz-1990MHz; LTE FDD Band 4 Uplink: 1710MHz-1755MHz, Downlink: 2110MHz-2155MHz; LTE FDD Band 5 Uplink: 824MHz-849MHz, Downlink: 869MHz-894MHz; LTE-FDD Band 7 Uplink: 2500MHz-2570MHz, Downlink: 2620MHz-2690MHz; LTE FDD Band 17 Uplink: 704MHz-716MHz, Downlink: 734MHz-746MHz;
Type of Modulation:	QPSK/16QAM
Power Class	Class 3
Antenna:	PIFA Antenna
Antenna gain:	1dBi
Power Supply:	DC 3.8V, 6000mAh from battery or DC 5V from Adapter.
Adapter:	Model: TEKA-UCA20US Input: 100-240V~50/60Hz 0.35A MAX Output: 5.0V $\overline{\text{---}}$ 2.0A
Extreme Vol. Limits:	DC 3.4V to DC 4.2V (Nominal DC 3.8V) (Note 1)
HW Version	S8667-T310-V1.0
SW Version	Android 11
** Note1: The High Voltage 4.2V and Low Voltage 3.4V was declared by manufacturer, The EUT couldn't be operate normally with higher or lower voltage.	

1.2 RELATED SUBMITTAL(S) / GRANT (S)

This submittal(s) (test report) is intended for **FCC ID: 2A270-AT1012U** filing to comply with the FCC Part 22H&24E &27.

1.3 TEST METHODOLOGY

The tests documented in this report were performed in accordance with ANSI/TIA-603-E-2016, FCC CFR 47 Part 2, Part 22, Part 24, Part 27, ANSI C63.26:2015.

1.4 TEST FACILITY

The test site used to collect the radiated data is located at:

ShenZhen NTEK Testing Technology Co., Ltd.

1/F, Building E, Fenda Science Park, Sanwei Community, Xixiang Street, Bao’an District, Shenzhen 518126 P.R.China.

The test site is constructed and calibrated to meet the FCC requirements in documents ANSI C63.26:2015& ANSI C63.4: 2014.

FCC Registration No.:463705

IC Registration No.:9270A-1,

CNAS Registration No.:L5516

MEASUREMENT UNCERTAINTY

The reported uncertainty of measurement, where expended uncertainty U is based on a standard uncertainty multiplied by a coverage factor of k=2, providing a level of confidence of approximately 95 %.

No.	Item	Uncertainty
1	Measuring Uncertainty for a Level of Confidence of 95% ($U = 2Uc(y)$)	2.5dB
2	Conducted Emission Test	±1.38dB
3	RF power, conducted	±0.16dB
4	Spurious emissions, conducted	±0.21dB
5	All emissions, radiated(<1G)	±4.68dB
6	All emissions, radiated(>1G)	±4.89dB
7	Temperature	±0.5°C
8	Humidity	±2%
9	Frequency error, conducted	±0.19 ppm

1.5 SPECIAL ACCESSORIES

The battery and the charger, earphone supplied by the applicant were used as accessories and being tested with EUT intended for FCC grant together.

1.6 WORST-CASE CONFIGURATION AND MODE

The worst-case scenario for all measurements is based on the investigation results.

The device has LTE Bands of: Band 2, Band 4, Band 5, Band 7, Band 17

The RB Size was selected to measure for peak or average ERP and EIRP, which was based on the conducted power verification baseline data.

For the fundamental investigation of radiated emissions, the EUT is investigated for vertical and horizontal antenna orientations and X Y and Z orientations of the EUT alone. After the investigations the worst case was determined to be at X orientation for all LTE bands.

1.6 SUMMARY OF TEST RESULTS

FCC Part22, Subpart H/ FCC Part24, Subpart E, FCC Part27, Subpart L, KDB 971168 D01 Power Meas License Digital Systems v03			
FCC Rule	Test Item	Verdict	Remark
2.1046	Conducted Output Power	PASS	
22.913(d) 24.232(d) 27.50(d)(5) KDB 971168 D01 Clause 5.7	Peak-to-Average Ratio	PASS	
2.1049 22.917(b) 24.238(b) KDB 971168 D01 Clause 4.2	Occupied Bandwidth	PASS	
2.1051 22.917(a) 24.238(a) 27.53(c), (g), (h) KDB 971168 D01 Clause 6	Band Edge	PASS	
22.913(a)(2) 27.50(b)(10), (c)(10) KDB 971168 D01 Clause 5.6	Effective Radiated Power	PASS	
24.232(c) 27.50(h)(2), (d)(4) KDB 971168 D01 Clause 5.6	Equivalent Isotropic Radiated Power	PASS	

2.1053 22.917(a) 24.238(a) 27.53(c)(g)(h)(m) KDB 971168 D01 Clause 7	Field Strength of Spurious Radiation	PASS	
2.1055 22.355 24.235 27.54 KDB 971168 D01 Clause 9	Frequency Stability for Temperature & Voltage	PASS	
2.1051 22.917(a) 24.238(a) 27.53(c)(g)(h)(m) KDB 971168 D01 Clause 6	Conducted Emission	PASS	

Remark:

1. "N/A" denotes test is not applicable in this Test Report.
2. All test items were verified and recorded according to the standards and without any deviation during the test.
3. No modifications are made to the EUT during all test items.

2. SYSTEM TEST CONFIGURATION

2.1 EUT CONFIGURATION

The EUT configuration for testing is installed on RF field strength measurement to meet the Commission's requirement and operating in a manner which intends to maximize its emission characteristics in a continuous normal application.

2.2 EUT EXERCISE

The Transmitter was operated in the maximum output power mode through Communication Tester. The TX frequency was fixed which was for the purpose of the measurements.

2.3 CONFIGURATION OF EUT SYSTEM

Table 2-1 Equipment Used in EUT System

Item	Equipment	Model No.	ID or Specification	Note
1	Tablet PC	AT1012U	FCC ID: 2A27O-AT1012U	EUT

*Note: All the accessories have been used during the test.
the following "EUT" in setup diagram means EUT system.*

2.4 TEST SETUP

For Radiated Test Cases

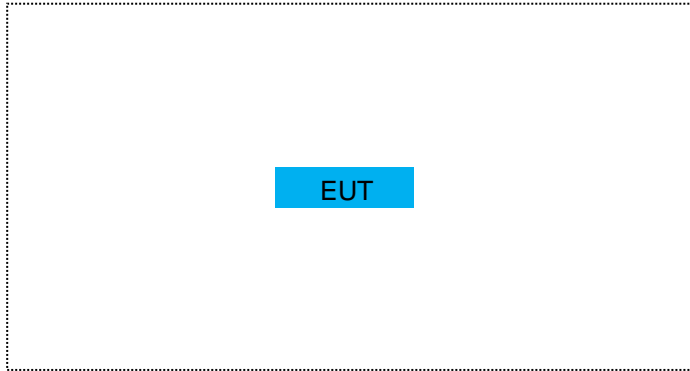

For Conducted Output Power

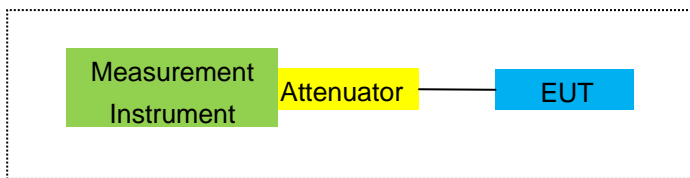

For Peak-to Average Ratio, Occupied Bandwidth, Conducted Band edge and Conducted Spurious Emission

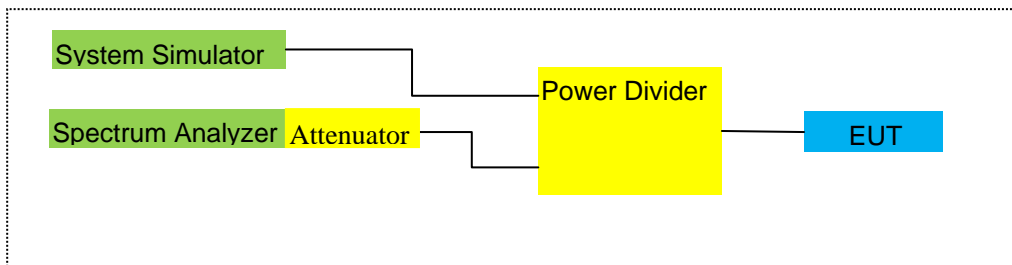

For Frequency Stability

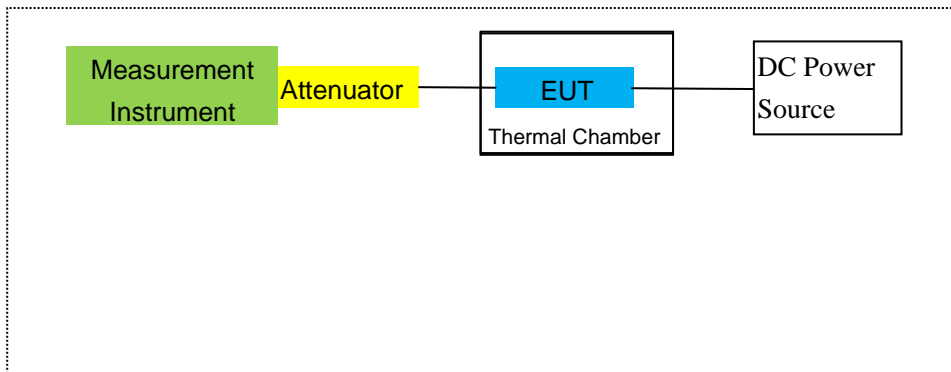

Note: EUT built-in battery-powered, the battery is fully-charged.

3. TEST AND MEASUREMENT EQUIPMENT

The following test and measurement equipment was utilized for the tests documented in this report:

Item	Kind of Equipment	Manufacturer	Type No.	Serial No.	Last calibration	Calibrated until	Calibration period
1	MXA Signal Analyzer	Agilent	N9020A	MY49100060	2021.07.01	2022.06.30	1 year
2	Test Receiver	R&S	ESPI	101318	2021.04.27	2022.04.26	1 year
3	Bilog Antenna	TESEQ	CBL6111D	31216	2021.03.29	2022.03.28	1 year
4	50Ω Coaxial Switch	Anritsu	MP59B	6200983705	2020.05.11	2023.05.10	3 year
5	Horn Antenna	EM	EM-AH-10180	2011071402	2021.03.29	2022.03.28	1 year
6	Horn Ant	Schwarzbeck	BBHA 9170	9170-181	2020.11.20	2021.11.19	1 year
7	Amplifier	EM	EM-30180	060538	2021.07.01	2022.06.30	1 year
8	Loop Antenna	ARA	PLA-1030/B	1029	2021.04.27	2022.04.26	1 year
9	Power Meter	R&S	NRVS	100696	2021.07.01	2022.06.30	1 year
10	Power Sensor	R&S	URV5-Z4	0395.1619.05	2021.04.27	2022.04.26	1 year
11	Test Cable	N/A	R-01	N/A	2019.08.06	2022.08.05	3 year
12	Test Cable	N/A	R-02	N/A	2019.08.06	2022.08.05	3 year
13	Test Cable	N/A	R-03	N/A	2019.06.28	2022.06.27	3 year
14	Test Receiver	R&S	ESCI	101160	2021.04.27	2022.04.26	1 year
15	LISN	R&S	ENV216	101313	2021.04.27	2022.04.26	1 year
16	LISN	EMCO	3816/2	00042990	2021.04.27	2022.04.26	1 year
17	50Ω Coaxial Switch	Anritsu	MP59B	6200264417	2021.04.27	2022.04.26	1 year
18	Passive Voltage Probe	R&S	ESH2-Z3	100196	2021.04.27	2022.04.26	1 year
19	Test Cable	N/A	C01	N/A	2020.05.11	2023.05.10	3 year
20	Test Cable	N/A	C02	N/A	2020.05.11	2023.05.10	3 year
21	Test Cable	N/A	C03	N/A	2020.05.11	2023.05.10	3 year
22	Attenuator	MCE	24-10-34	BN9258	2021.04.27	2022.04.26	1 year
23	Spectrum Analyzer	agilent	e4440a	us44300399	2021.04.27	2022.04.26	1 year
24	test receiver	R&S	ESCI	a0304218	2021.04.27	2022.04.26	1 year
25	Communication Tester	R&S	CMU200	A0304247	2021.07.01	2022.06.30	1 year
26	Thermal Chamber	Ten Billion	TTC-B3C	TBN-960502	2021.04.27	2022.04.26	1 year

27	DC Power Source	N/A	PS-6005D	2017040292 3	2020.05.11	2023.05.10	3 year
28	PSG Analog Signal Generator	Agilent	E8257D	MY51110112	2021.07.01	2022.06.30	1 year
29	Communication Tester	R&S	CMW500	148500	2021.07.01	2022.06.30	1 year
30	PSG Analog Signal Generator	Agilent	E8257D	MY51110112	2021.07.01	2022.06.30	1 year

Note: Each piece of equipment is scheduled for calibration once a year except the Test Cable& DC Power Source which is scheduled for calibration every 3 years.

4. OUTPUT POWER

4.1 OUTPUT POWER MEASUREMENT

LTE Measurement Procedure:

All LTE bands conducted power peak and average are obtained from the CMW500 telecommunication test set. The following tests were conducted according to the test requirements outlined in section 6.2 of the 3GPP TS36.101 specification.

UE Power Class: 3 (23 +/- 2dBm). The allowed Maximum Power Reduction (MPR) for the maximum output power due to higher order modulation and transmit bandwidth configuration (resource blocks) is specified in Table 6.2.3-1 of the 3GPP TS36.101.

Table 6.2.3-1: Maximum Power Reduction (MPR) for Power Class 3

Modulation	Channel bandwidth / Transmission bandwidth (RB)						MPR (dB)
	1.4 MHz	3.0 MHz	5 MHz	10 MHz	15 MHz	20 MHz	
QPSK	> 5	> 4	> 8	> 12	> 16	> 18	≤ 1
16 QAM	≤ 5	≤ 4	≤ 8	≤ 12	≤ 16	≤ 18	≤ 1
16 QAM	> 5	> 4	> 8	> 12	> 16	> 18	≤ 2

The allowed A-MPR values specified below in Table 6.2.4.-1 of 3GPP TS36.101 are in addition to the allowed MPR requirements. All the measurements below were performed with A-MPR disabled, by using Network Signaling Value of "NS_01".3

Table 6.2.4-1: Additional Maximum Power Reduction (A-MPR)

Network Signalling value	Requirements (sub-clause)	E-UTRA Band	Channel bandwidth (MHz)	Resources Blocks (N_{RB})	A-MPR (dB)
NS_01	6.6.2.1.1	Table 5.5-1	1.4, 3, 5, 10, 15, 20	Table 5.6-1	NA
NS_03	6.6.2.2.1	2, 4, 10, 23, 25, 35, 36	3	>5	≤ 1
			5	>6	≤ 1
			10	>6	≤ 1
			15	>8	≤ 1
			20	>10	≤ 1
NS_04	6.6.2.2.2	41	5	>6	≤ 1
			10, 15, 20	See Table 6.2.4-4	
NS_05	6.6.3.3.1	1	10,15,20	≥ 50	≤ 1
NS_06	6.6.2.2.3	12, 13, 14, 17	1.4, 3, 5, 10	Table 5.6-1	n/a
NS_07	6.6.2.2.3	13	10	Table 6.2.4-2	Table 6.2.4-2
	6.6.3.3.2				
NS_08	6.6.3.3.3	19	10, 15	> 44	≤ 3
NS_09	6.6.3.3.4	21	10, 15	> 40	≤ 1
				> 55	≤ 2
NS_10		20	15, 20	Table 6.2.4-3	Table 6.2.4-3
NS_11	6.6.2.2.1	23 ¹	1.4, 3, 5, 10	Table 6.2.4-5	Table 6.2.4-5
..					
NS_32	-	-	-	-	-

Note 1: Applies to the lower block of Band 23, i.e. a carrier placed in the 2000-2010 MHz region.

Test data reference attachment.

5. OCCUPIED BANDWIDTH

RULE PART(S)

FCC: §2.1049

LIMITS

For reporting purposes only

TEST PROCEDURE

The transmitter output was connected to a calibrated coaxial cable and coupler, the other end of which was connected to a spectrum analyzer. The occupied bandwidth was measured with the spectrum analyzer at the low, middle and high channel in each band. The -26dB bandwidth was also measured and recorded.

MODES TESTED

- LTE Band 2
- LTE Band 4
- LTE Band 5
- LTE Band 7
- LTE Band 17

RESULTS

PASS

Test data reference attachment.

6. BANDEDGE AND EMISSION MASK

RULE PART(S)

FCC: §2.1051, §22.917(a), §24.238(a), §27.53(c)(g)(h)(m)

FCC: §2.1046, §22.913, §24.232

LIMITS

The minimum permissible attenuation level of any spurious emission is $43 + \log_{10}(P[\text{Watts}])$, where P is the transmitter power in Watts.

The minimum permissible attenuation level for Band 7 is as following.

Per 27.53(g) for operations in the 698-746 MHz band, in the 100 kHz bands immediately outside and adjacent to the frequency block a resolution bandwidth of at least 30 kHz may be employed to demonstrate compliance with the out-of-band emissions limit.

Per 27.53(c.5) for operations in the 776-788 MHz band, in the 100 kHz bands immediately outside and adjacent to the frequency block a resolution bandwidth of at least 30 kHz may be employed to demonstrate compliance with the out-of-band emissions limit.

For all plots showing emissions in the 763 – 775MHz and 793 – 805MHz band, the FCC limit per 27.53(c.4) is $65 + 10\log_{10}(P) = -35\text{dBm}$ in a 6.25kHz bandwidth.

Per 27.53(m) for operations in the BRS/EBS bands, the attenuation factor shall be not less than $40 + 10 \log (P)$ dB on all frequencies between the channel edge and 5 megahertz from the channel edge, $43 + 10 \log (P)$ dB on all frequencies between 5 megahertz and X megahertz from the channel edge, and $55 + 10 \log (P)$ dB on all frequencies more than X megahertz from the channel edge, where X is the greater of 6 megahertz or the actual emission bandwidth.

TEST PROCEDURE

The transmitter output was connected to a CMW500 Test Set and configured to operate at maximum power. The band edge emissions were measured at the required operating frequencies in each band on the Spectrum Analyzer.

For each band edge measurement:

Set the spectrum analyzer span to include the block edge frequency

Set a marker to point the corresponding band edge frequency in each test case.

Set display line

Set resolution bandwidth to at least 1% of emission bandwidth.

MODES TESTED

- LTE Band 2/4/5/7/17

RESULTS

Test data reference attachment.

7. OUT OF BAND EMISSIONS

RULE PART(S)

FCC: §2.1051, §22.917(a), §24.238(a), §27.53(c)(g)(h)(m)

LIMITS

The minimum permissible attenuation level of any spurious emission is $43 + \log_{10}(P[\text{Watts}])$, where P is the transmitter power in Watts.

The minimum permissible attenuation level for Band 7 is as following.

Per 27.53(g) for operations in the 698-746 MHz band, in the 100 kHz bands immediately outside and adjacent to the frequency block a resolution bandwidth of at least 30 kHz may be employed to demonstrate compliance with the out-of-band emissions limit.

Per 27.53(c.5) for operations in the 776-788 MHz band, in the 100 kHz bands immediately outside and adjacent to the frequency block a resolution bandwidth of at least 30 kHz may be employed to demonstrate compliance with the out-of-band emissions limit.

For all plots showing emissions in the 763 – 775MHz and 793 – 805MHz band, the FCC limit per 27.53(c.4) is $65 + 10\log_{10}(P) = -35\text{dBm}$ in a 6.25kHz bandwidth.

Per 27.53(m) for operations in the BRS/EBS bands, the attenuation factor shall be not less than $40 + 10 \log (P)$ dB on all frequencies between the channel edge and 5 megahertz from the channel edge, $43 + 10 \log (P)$ dB on all frequencies between 5 megahertz and X megahertz from the channel edge, and $55 + 10 \log (P)$ dB on all frequencies more than X megahertz from the channel edge, where X is the greater of 6 megahertz or the actual emission bandwidth.

TEST PROCEDURE

The RF output of the transmitter was connected to a spectrum analyzer through a calibrated coaxial cable. Sufficient scans were taken to show the out-of-band Emissions, if any, up to 10th harmonic. Multiple sweeps were recorded in maximum hold mode using a peak detector to ensure that the worst-case emissions were caught.

For each out of band emissions measurement:

- Set display line
- Set RBW & VBW to 100 kHz for the measurement below 1 GHz, and 1 MHz for the measurement above 1 GHz.

MODES TESTED

- LTE Band 2
- LTE Band 4
- LTE Band 5
- LTE Band 7
- LTE Band 17

7.1 MEASUREMENT METHOD

The test set up and general procedure is similar to conducted peak output power test. Only different for setting the measurement configuration of the measuring instrument of Spectrum Analyzer.

Test data reference attachment.

8. RADIATED MEASUREMENT

8.1. RADIATED POWER (ERP & EIRP)

RULE PART(S)

FCC: §2.1046, §22.913(a)(2), §24.232(c) and §27.50 (h)(2), (b)(10), (c)(10), (d)(4)

LIMITS:

22.913(a) (2)- The ERP of mobile transmitters and auxiliary test transmitters must not exceed 7 Watts.
24.232 (c) Mobile and portable stations are limited to 2 watts EIRP.
27.50 (c) (10) the following power and antenna height requirements apply to stations transmitting in the 698–746 MHz band, the portable stations (hand-held devices) are limited to 3 watts ERP.
27.50 (b)(10) Portable stations (hand-held devices) transmitting in the 746–757 MHz, 758–763 MHz, 776–793 MHz, and 805–806 MHz bands are limited to 3 watts ERP.
27.50 (d)(4) The following power and antenna height requirements apply to stations transmitting in the 1710–1755 MHz and 2110–2155 MHz bands: Fixed, mobile, and portable (hand-held) stations operating in the 1710–1755 MHz band are limited to 1 watt EIRP.
27.50 (h)(2) Mobile and other user stations in the 2500–2570 MHz and 2620–2690 MHz bands. Mobile stations are limited to 2.0 watts EIRP. All user stations are limited to 2.0 watts transmitter output power.

TEST PROCEDURE

ANSI/TIA-603-E Clause 2.2.17

KDB 971168 v02r01 RF power output using broadband peak and average power meter method.

KDB 971168 D01 Power Meas License Digital Systems v02r01, “Measurement Guidance for Certification of Licensed Digital Transmitters”

MODES TESTED

- LTE Band 2
- LTE Band 4
- LTE Band 5
- LTE Band 7
- LTE Band 17

RESULTS

Pass

8.2 LTE BAND 2

Radiated Power (EIRP) for Band 2									
Mode	RB/RB SIZE	Frequency	Result						Conclusion
			SG Level (dBm)	Cable Loss (dBm)	Antenna Gain (dB)	Max. EIRP Average (dBm)	Max. EIRP Average (mW)	Polarization Of Max. ERP	
1.4MHz Band QPSK	1/#Mid	1850.7	-1.60	3.76	28.24	22.88	194.089	Horizontal	Pass
		1880	-1.41	3.91	28.22	22.90	194.984	Horizontal	Pass
		1909.3	-1.32	3.93	28.20	22.95	197.242	Horizontal	Pass
3.0MHz Band QPSK	1/#Mid	1851.5	-1.66	3.77	28.23	22.80	190.546	Horizontal	Pass
		1880	-1.51	3.91	28.24	22.82	191.426	Horizontal	Pass
		1908.5	-1.38	3.94	28.25	22.93	196.336	Horizontal	Pass
5.0MHz Band QPSK	1/#Mid	1852.5	-1.55	3.77	28.31	22.99	199.067	Horizontal	Pass
		1880	-1.17	3.91	28.22	23.14	206.063	Horizontal	Pass
		1907.5	-1.10	3.94	28.20	23.16	207.014	Horizontal	Pass
10.0MHz Band QPSK	1/#Mid	1855	-1.41	3.79	28.33	23.13	205.589	Horizontal	Pass
		1880	-1.11	3.95	28.22	23.16	207.014	Horizontal	Pass
		1905	-1.00	3.97	28.19	23.22	209.894	Horizontal	Pass
15.0MHz Band QPSK	1/#Mid	1857.5	-1.37	3.79	28.34	23.18	207.970	Horizontal	Pass
		1880	-1.16	3.95	28.22	23.11	204.644	Horizontal	Pass
		1902.5	-1.02	3.97	28.18	23.19	208.449	Horizontal	Pass
20.0MHz Band QPSK	1/#Mid	1860	-1.36	3.81	28.35	23.18	207.970	Horizontal	Pass
		1880	-1.03	3.96	28.22	23.23	210.378	Horizontal	Pass
		1900	-0.97	4.00	28.16	23.19	208.449	Horizontal	Pass
1.4MHz Band QPSK	1/#Mid	1850.7	-2.66	3.76	28.24	21.82	152.055	Vertical	Pass
		1880	-2.51	3.91	28.22	21.80	151.356	Vertical	Pass
		1909.3	-2.34	3.93	28.20	21.93	155.955	Vertical	Pass
3.0MHz Band QPSK	1/#Mid	1851.5	-2.75	3.77	28.23	21.71	148.252	Vertical	Pass
		1880	-2.32	3.91	28.24	22.01	158.855	Vertical	Pass
		1908.5	-1.90	3.94	28.25	22.41	174.181	Vertical	Pass
5.0MHz Band QPSK	1/#Mid	1852.5	-2.00	3.77	28.31	22.54	179.473	Vertical	Pass
		1880	-2.08	3.91	28.22	22.23	167.109	Vertical	Pass
		1907.5	-1.81	3.94	28.20	22.45	175.792	Vertical	Pass
10.0MHz Band QPSK	1/#Mid	1855	-2.26	3.79	28.33	22.28	169.044	Vertical	Pass
		1880	-1.85	3.95	28.22	22.42	174.582	Vertical	Pass
		1905	-2.10	3.97	28.19	22.12	162.930	Vertical	Pass

15.0MHz		1857.5	-2.70	3.79	28.34	21.85	153.109	Vertical	Pass
Band	1/#Mid	1880	-2.61	3.95	28.22	21.66	146.555	Vertical	Pass
QPSK		1902.5	-1.81	3.97	28.18	22.40	173.780	Vertical	Pass
20.0MHz		1860	-2.16	3.81	28.35	22.38	172.982	Vertical	Pass
Band	1/#Mid	1880	-2.23	3.96	28.22	22.03	159.588	Vertical	Pass
QPSK		1900	-2.06	4.00	28.16	22.10	162.181	Vertical	Pass

Note:

SG Level= Signal generator output

Max. EIRP Average (dBm)= Antenna Gain(dB)+ SG Level (dBm)- Cable Loss(dBm)

Radiated Power (EIRP) for Band 2									
Mode	RB/RB SIZE	Frequency	Result						Conclusion
			SG Level (dBm)	Cable Loss (dBm)	Antenna Gain (dB)	Max. EIRP Average (dBm)	Max. EIRP	Polarization Of Max. ERP	
							(mW)		
1.4MHz	Band 16 QAM	1850.7	-2.72	3.76	28.24	21.76	149.968	Horizontal	Pass
1880		-2.19	3.91	28.22	22.12	162.930	Horizontal	Pass	
1909.3		-2.12	3.93	28.20	22.15	164.059	Horizontal	Pass	
3.0MHz	Band 16 QAM	1851.5	-2.22	3.77	28.23	22.24	167.494	Horizontal	Pass
1880		-2.30	3.91	28.24	22.03	159.588	Horizontal	Pass	
1908.5		-2.51	3.94	28.25	21.80	151.356	Horizontal	Pass	
5.0MHz	Band 16 QAM	1852.5	-2.16	3.77	28.31	22.38	172.982	Horizontal	Pass
1880		-2.07	3.91	28.22	22.24	167.494	Horizontal	Pass	
1907.5		-1.75	3.94	28.20	22.51	178.238	Horizontal	Pass	
10.0MHz	Band 16 QAM	1855	-2.21	3.79	28.33	22.33	171.002	Horizontal	Pass
1880		-2.20	3.95	28.22	22.07	161.065	Horizontal	Pass	
1905		-1.67	3.97	28.19	22.55	179.887	Horizontal	Pass	
15.0MHz	Band 16 QAM	1857.5	-2.19	3.79	28.34	22.36	172.187	Horizontal	Pass
1880		-1.98	3.95	28.22	22.29	169.434	Horizontal	Pass	
1902.5		-1.94	3.97	28.18	22.27	168.655	Horizontal	Pass	
20.0MHz	Band 16 QAM	1860	-2.08	3.81	28.35	22.46	176.198	Horizontal	Pass
1880		-1.78	3.96	28.22	22.48	177.011	Horizontal	Pass	
1900		-1.60	4.00	28.16	22.56	180.302	Horizontal	Pass	
1.4MHz	Band 16 QAM	1850.7	-3.77	3.76	28.24	20.71	117.761	Vertical	Pass
1880		-2.93	3.91	28.22	21.38	137.404	Vertical	Pass	
1909.3		-3.01	3.93	28.20	21.26	133.660	Vertical	Pass	
3.0MHz	Band 16 QAM	1851.5	-3.24	3.77	28.23	21.22	132.434	Vertical	Pass
1880		-3.40	3.91	28.24	20.93	123.880	Vertical	Pass	
1908.5		-3.48	3.94	28.25	20.83	121.060	Vertical	Pass	
5.0MHz	Band 16 QAM	1852.5	-2.99	3.77	28.31	21.55	142.889	Vertical	Pass
1880		-3.59	3.91	28.22	20.72	118.032	Vertical	Pass	
1907.5		-2.88	3.94	28.20	21.38	137.404	Vertical	Pass	
10.0MHz	Band 16 QAM	1855	-3.45	3.79	28.33	21.09	128.529	Vertical	Pass
1880		-2.90	3.95	28.22	21.37	137.088	Vertical	Pass	
1905		-3.48	3.97	28.19	20.74	118.577	Vertical	Pass	
15.0MHz	Band 16	1857.5	-3.77	3.79	28.34	20.78	119.674	Vertical	Pass
1880		-2.86	3.95	28.22	21.41	138.357	Vertical	Pass	

QAM		1902.5	-2.68	3.97	28.18	21.53	142.233	Vertical	Pass
20.0MHz	1/#Mid	1860	-3.66	3.81	28.35	20.88	122.462	Vertical	Pass
Band 16		1880	-3.48	3.96	28.22	20.78	119.674	Vertical	Pass
QAM		1900	-3.22	4.00	28.16	20.94	124.165	Vertical	Pass

Note:

SG Level= Signal generator output

Max. EIRP Average (dBm)= Antenna Gain(dB)+ SG Level (dBm)- Cable Loss(dBm)

8.3 LTE BAND 4

Radiated Power (EIRP) for Band 4									
Mode	RB/RB SIZE	Frequency	Result						Conclusion
			SG Level	Cable Loss	Antenna Gain	Max. EIRP	Max. EIRP	Polarization Of Max. ERP	
			(dBm)	(dBm)	(dB)	Average	Average		
						(dBm)	(mW)		
1.4MHz Band QPSK	1/#Mid	1710.7	-1.51	3.12	27.58	22.95	197.242	Horizontal	Pass
		1732.5	-1.50	3.27	27.61	22.84	192.309	Horizontal	Pass
		1754.3	-1.48	3.29	27.63	22.86	193.197	Horizontal	Pass
3.0MHz Band QPSK	1/#Mid	1711.5	-1.68	3.13	27.61	22.80	190.546	Horizontal	Pass
		1732.5	-1.60	3.27	27.61	22.74	187.932	Horizontal	Pass
		1753.5	-1.52	3.30	27.62	22.80	190.546	Horizontal	Pass
5.0MHz Band QPSK	1/#Mid	1712.5	-1.45	3.13	27.63	23.05	201.837	Horizontal	Pass
		1732.5	-1.35	3.27	27.61	22.99	199.067	Horizontal	Pass
		1752.5	-1.23	3.30	27.60	23.07	202.768	Horizontal	Pass
10.0MHz Band QPSK	1/#Mid	1715	-1.39	3.15	27.64	23.10	204.174	Horizontal	Pass
		1732.5	-1.16	3.31	27.61	23.14	206.063	Horizontal	Pass
		1750	-1.18	3.33	27.59	23.08	203.236	Horizontal	Pass
15.0MHz Band QPSK	1/#Mid	1717.5	-1.40	3.15	27.65	23.10	204.174	Horizontal	Pass
		1732.5	-1.24	3.31	27.61	23.06	202.302	Horizontal	Pass
		1747.5	-1.18	3.33	27.57	23.06	202.302	Horizontal	Pass
20.0MHz Band QPSK	1/#Mid	1720	-1.34	3.17	27.66	23.15	206.538	Horizontal	Pass
		1732.5	-1.17	3.32	27.61	23.12	205.116	Horizontal	Pass
		1745	-1.11	3.36	27.56	23.09	203.704	Horizontal	Pass
1.4MHz Band QPSK	1/#Mid	1710.7	-2.45	3.12	27.58	22.01	158.855	Vertical	Pass
		1732.5	-2.08	3.27	27.61	22.26	168.267	Vertical	Pass
		1754.3	-2.45	3.29	27.63	21.89	154.525	Vertical	Pass
3.0MHz Band QPSK	1/#Mid	1711.5	-2.77	3.13	27.61	21.71	148.252	Vertical	Pass
		1732.5	-1.98	3.27	27.61	22.36	172.187	Vertical	Pass
		1753.5	-1.79	3.30	27.62	22.53	179.061	Vertical	Pass
5.0MHz Band QPSK	1/#Mid	1712.5	-2.08	3.13	27.63	22.42	174.582	Vertical	Pass
		1732.5	-1.88	3.27	27.61	22.46	176.198	Vertical	Pass
		1752.5	-1.93	3.30	27.60	22.37	172.584	Vertical	Pass
10.0MHz Band QPSK	1/#Mid	1715	-2.42	3.15	27.64	22.07	161.065	Vertical	Pass
		1732.5	-2.06	3.31	27.61	22.24	167.494	Vertical	Pass
		1750	-2.59	3.33	27.59	21.67	146.893	Vertical	Pass

15.0MHz		1717.5	-2.89	3.15	27.65	21.61	144.877	Vertical	Pass
Band	1/#Mid	1732.5	-2.47	3.31	27.61	21.83	152.405	Vertical	Pass
QPSK		1747.5	-2.10	3.33	27.57	22.14	163.682	Vertical	Pass
20.0MHz		1720	-2.48	3.17	27.66	22.01	158.855	Vertical	Pass
Band	1/#Mid	1732.5	-2.17	3.32	27.61	22.12	162.930	Vertical	Pass
QPSK		1745	-1.88	3.36	27.56	22.32	170.608	Vertical	Pass

Note:

SG Level= Signal generator output

Max. EIRP Average (dBm)= Antenna Gain(dB)+ SG Level (dBm)- Cable Loss(dBm)

Radiated Power (EIRP) for Band 4									
Mode	RB/RB SIZE	Frequency	Result						Conclusion
			SG Level	Cable Loss	Antenna Gain	Max. EIRP	Max. EIRP	Polarization	
			(dBm)	(dBm)	(dB)	Average	Average	Of Max. ERP	
					(dBm)	(mW)			
1.4MHz Band 16 QAM	1/#Mid	1710.7	-2.32	3.12	27.58	22.14	163.682	Horizontal	Pass
		1732.5	-2.17	3.27	27.61	22.17	164.816	Horizontal	Pass
		1754.3	-2.17	3.29	27.63	22.17	164.816	Horizontal	Pass
3.0MHz Band 16 QAM	1/#Mid	1711.5	-2.26	3.13	27.61	22.22	166.725	Horizontal	Pass
		1732.5	-2.39	3.27	27.61	21.95	156.675	Horizontal	Pass
		1753.5	-2.61	3.30	27.62	21.71	148.252	Horizontal	Pass
5.0MHz Band 16 QAM	1/#Mid	1712.5	-2.09	3.13	27.63	22.41	174.181	Horizontal	Pass
		1732.5	-2.05	3.27	27.61	22.29	169.434	Horizontal	Pass
		1752.5	-1.74	3.30	27.60	22.56	180.302	Horizontal	Pass
10.0MHz Band 16 QAM	1/#Mid	1715	-2.16	3.15	27.64	22.33	171.002	Horizontal	Pass
		1732.5	-2.35	3.31	27.61	21.95	156.675	Horizontal	Pass
		1750	-1.73	3.33	27.59	22.53	179.061	Horizontal	Pass
15.0MHz Band 16 QAM	1/#Mid	1717.5	-1.96	3.15	27.65	22.54	179.473	Horizontal	Pass
		1732.5	-2.02	3.31	27.61	22.28	169.044	Horizontal	Pass
		1747.5	-2.04	3.33	27.57	22.20	165.959	Horizontal	Pass
20.0MHz Band 16 QAM	1/#Mid	1720	-1.91	3.17	27.66	22.58	181.134	Horizontal	Pass
		1732.5	-1.92	3.32	27.61	22.37	172.584	Horizontal	Pass
		1745	-1.73	3.36	27.56	22.47	176.604	Horizontal	Pass
1.4MHz Band 16 QAM	1/#Mid	1710.7	-3.13	3.12	27.58	21.33	135.831	Vertical	Pass
		1732.5	-2.84	3.27	27.61	21.50	141.254	Vertical	Pass
		1754.3	-2.91	3.29	27.63	21.43	138.995	Vertical	Pass
3.0MHz Band 16 QAM	1/#Mid	1711.5	-3.08	3.13	27.61	21.40	138.038	Vertical	Pass
		1732.5	-3.68	3.27	27.61	20.66	116.413	Vertical	Pass
		1753.5	-3.31	3.30	27.62	21.01	126.183	Vertical	Pass
5.0MHz Band 16 QAM	1/#Mid	1712.5	-2.96	3.13	27.63	21.54	142.561	Vertical	Pass
		1732.5	-3.73	3.27	27.61	20.61	115.080	Vertical	Pass
		1752.5	-3.24	3.30	27.60	21.06	127.644	Vertical	Pass
10.0MHz Band 16 QAM	1/#Mid	1715	-3.67	3.15	27.64	20.82	120.781	Vertical	Pass
		1732.5	-3.36	3.31	27.61	20.94	124.165	Vertical	Pass
		1750	-3.29	3.33	27.59	20.97	125.026	Vertical	Pass
15.0MHz Band 16	1/#Mid	1717.5	-3.87	3.15	27.65	20.63	115.611	Vertical	Pass
		1732.5	-2.87	3.31	27.61	21.43	138.995	Vertical	Pass

QAM		1747.5	-3.15	3.33	27.57	21.09	128.529	Vertical	Pass
20.0MHz		1720	-3.50	3.17	27.66	20.99	125.603	Vertical	Pass
Band 16	1/#Mid	1732.5	-3.37	3.32	27.61	20.92	123.595	Vertical	Pass
QAM		1745	-3.46	3.36	27.56	20.74	118.577	Vertical	Pass

Note:

SG Level= Signal generator output

Max. EIRP Average (dBm)= Antenna Gain(dB)+ SG Level (dBm)- Cable Loss(dBm)

8.4 LTE BAND 5

Radiated Power (ERP) for Band 5											
Mode	RB/RB SIZE	Frequency	Result							Polarization Of Max. ERP	Conclusion
			SG Level	Cable Loss	Antenna Gain	Correction	Max. EIRP	Max. EIRP			
			(dBm)	(dBm)	(dB)		Average	Average			
						(dB)	(dBm)	(mW)			
1.4MHz Band QPSK	3/#Mid	824.7	7.89	2.01	19.68	2.15	23.41	219.280	Horizontal	Pass	
		836.5	7.77	2.01	19.77	2.15	23.38	217.771	Horizontal	Pass	
		848.3	7.57	2.02	19.82	2.15	23.22	209.894	Horizontal	Pass	
3.0MHz Band QPSK	1/#Mid	825.5	7.66	2.01	19.70	2.15	23.20	208.930	Horizontal	Pass	
		836.5	7.56	2.01	19.77	2.15	23.17	207.491	Horizontal	Pass	
		847.5	7.43	2.02	19.81	2.15	23.07	202.768	Horizontal	Pass	
5.0MHz Band QPSK	1/#Mid	826.5	7.94	2.01	19.71	2.15	23.49	223.357	Horizontal	Pass	
		836.5	7.82	2.01	19.77	2.15	23.43	220.293	Horizontal	Pass	
		846.5	7.66	2.02	19.79	2.15	23.28	212.814	Horizontal	Pass	
10.0MHz Band QPSK	1/#Mid	829	7.96	2.01	19.73	2.15	23.53	225.424	Horizontal	Pass	
		836.5	7.91	2.01	19.77	2.15	23.52	224.905	Horizontal	Pass	
		844	7.81	2.02	19.78	2.15	23.42	219.786	Horizontal	Pass	
1.4MHz Band QPSK	1/#Mid	824.7	6.66	2.01	19.68	2.15	22.18	165.196	Vertical	Pass	
		836.5	6.59	2.01	19.77	2.15	22.20	165.959	Vertical	Pass	
		848.3	6.52	2.02	19.82	2.15	22.17	164.816	Vertical	Pass	
3.0MHz Band QPSK	1/#Mid	825.5	6.85	2.01	19.70	2.15	22.39	173.380	Vertical	Pass	
		836.5	6.45	2.01	19.77	2.15	22.06	160.694	Vertical	Pass	
		847.5	6.53	2.02	19.81	2.15	22.17	164.816	Vertical	Pass	
5.0MHz Band QPSK	1/#Mid	826.5	7.03	2.01	19.71	2.15	22.58	181.134	Vertical	Pass	
		836.5	7.08	2.01	19.77	2.15	22.69	185.780	Vertical	Pass	
		846.5	6.97	2.02	19.79	2.15	22.59	181.552	Vertical	Pass	
10.0MHz Band QPSK	1/#Mid	829	6.28	2.01	19.73	2.15	21.85	153.109	Vertical	Pass	
		836.5	7.02	2.01	19.77	2.15	22.63	183.231	Vertical	Pass	
		844	6.44	2.02	19.78	2.15	22.05	160.325	Vertical	Pass	

Radiated Power (ERP) for Band 5											
Mode	RB/RB SIZE	Frequency	Result							Polarization Of Max. ERP	Conclusion
			SG Level	Cable Loss (dBm)	Antenna Gain (dB)	Correction (dB)	Max. EIRP Average (dBm)	Max. EIRP Average (mW)			
			(dBm)								
1.4MHz Band 16 QAM	3/#Mid	824.7	7.04	2.01	19.68	2.15	22.56	180.302	Horizontal	Pass	
		836.5	6.97	2.01	19.77	2.15	22.58	181.134	Horizontal	Pass	
		848.3	6.81	2.02	19.82	2.15	22.46	176.198	Horizontal	Pass	
3.0MHz Band 16 QAM	1/#Mid	825.5	7.12	2.01	19.70	2.15	22.66	184.502	Horizontal	Pass	
		836.5	6.83	2.01	19.77	2.15	22.44	175.388	Horizontal	Pass	
		847.5	6.31	2.02	19.81	2.15	21.95	156.675	Horizontal	Pass	
5.0MHz Band 16 QAM	1/#Mid	826.5	7.44	2.01	19.71	2.15	22.99	199.067	Horizontal	Pass	
		836.5	7.21	2.01	19.77	2.15	22.82	191.426	Horizontal	Pass	
		846.5	6.96	2.02	19.79	2.15	22.58	181.134	Horizontal	Pass	
10.0MHz Band 16 QAM	1/#Mid	829	7.44	2.01	19.73	2.15	23.01	199.986	Horizontal	Pass	
		836.5	7.16	2.01	19.77	2.15	22.77	189.234	Horizontal	Pass	
		844	6.70	2.02	19.78	2.15	22.31	170.216	Horizontal	Pass	
1.4MHz Band 16 QAM	1/#Mid	824.7	5.93	2.01	19.68	2.15	21.45	139.637	Vertical	Pass	
		836.5	5.30	2.01	19.77	2.15	20.91	123.310	Vertical	Pass	
		848.3	5.62	2.02	19.82	2.15	21.27	133.968	Vertical	Pass	
3.0MHz Band 16 QAM	1/#Mid	825.5	5.62	2.01	19.70	2.15	21.16	130.617	Vertical	Pass	
		836.5	6.91	2.01	19.77	2.15	22.52	178.649	Vertical	Pass	
		847.5	5.76	2.02	19.81	2.15	21.40	138.038	Vertical	Pass	
5.0MHz Band 16 QAM	1/#Mid	826.5	5.35	2.01	19.71	2.15	20.90	123.027	Vertical	Pass	
		836.5	5.83	2.01	19.77	2.15	21.44	139.316	Vertical	Pass	
		846.5	6.02	2.02	19.79	2.15	21.64	145.881	Vertical	Pass	
10.0MHz Band 16 QAM	1/#Mid	829	5.42	2.01	19.73	2.15	20.99	125.603	Vertical	Pass	
		836.5	6.80	2.01	19.77	2.15	22.41	174.181	Vertical	Pass	
		844	5.61	2.02	19.78	2.15	21.22	132.434	Vertical	Pass	

Note:

ERP=EIRP-2.15

SG Level= Signal generator output

Max. EIRP Average (dBm)= Antenna Gain(dB)+ SG Level (dBm)- Cable Loss(dBm)

8.5 LTE BAND 7

Radiated Power (EIRP) for Band 7									
Mode	RB/RB SIZE	Frequency	Result						Conclusion
			SG Level	Cable Loss	Antenna Gain	Max. EIRP	Max. EIRP	Polarization	
			(dBm)	(dBm)	(dB)	Average	Average	Of Max. ERP	
						(dBm)	(mW)		
5.0MHz Band QPSK	1/#Mid	2502.5	0.21	4.54	27.75	23.42	219.786	Horizontal	Pass
		2535	0.38	4.69	27.72	23.41	219.280	Horizontal	Pass
		2567.5	0.45	4.71	27.71	23.45	221.309	Horizontal	Pass
10.0MHz Band QPSK	1/#Mid	2505	0.28	4.55	27.76	23.49	223.357	Horizontal	Pass
		2535	0.47	4.69	27.72	23.50	223.872	Horizontal	Pass
		2565	0.55	4.72	27.70	23.53	225.424	Horizontal	Pass
15.0MHz Band QPSK	1/#Mid	2507.5	0.27	4.55	27.77	23.49	223.357	Horizontal	Pass
		2535	0.41	4.69	27.72	23.44	220.800	Horizontal	Pass
		2562.5	0.51	4.72	27.69	23.48	222.844	Horizontal	Pass
20.0MHz Band QPSK	1/#Mid	2510	0.33	4.57	27.78	23.54	225.944	Horizontal	Pass
		2535	0.51	4.73	27.72	23.50	223.872	Horizontal	Pass
		2560	0.55	4.75	27.68	23.48	222.844	Horizontal	Pass
5.0MHz Band QPSK	1/#Mid	2502.5	-1.16	4.54	27.75	22.05	160.325	Vertical	Pass
		2535	-0.78	4.69	27.72	22.25	167.880	Vertical	Pass
		2567.5	-0.46	4.71	27.71	22.54	179.473	Vertical	Pass
10.0MHz Band QPSK	1/#Mid	2505	-0.62	4.55	27.76	22.59	181.552	Vertical	Pass
		2535	-0.81	4.69	27.72	22.22	166.725	Vertical	Pass
		2565	-1.24	4.72	27.70	21.74	149.279	Vertical	Pass
15.0MHz Band QPSK	1/#Mid	2507.5	-1.29	4.55	27.77	21.93	155.955	Vertical	Pass
		2535	-1.29	4.69	27.72	21.74	149.279	Vertical	Pass
		2562.5	-0.75	4.72	27.69	22.22	166.725	Vertical	Pass
20.0MHz Band QPSK	1/#Mid	2510	-1.15	4.57	27.78	22.06	160.694	Vertical	Pass
		2535	-0.75	4.73	27.72	22.24	167.494	Vertical	Pass
		2560	-0.74	4.75	27.68	22.19	165.577	Vertical	Pass

Radiated Power (EIRP) for Band 7									
Mode	RB/RB SIZE	Frequency	Result						Conclusion
			SG Level	Cable Loss (dBm)	Antenna Gain (dB)	Max. EIRP	Max. EIRP	Polarization Of Max. ERP	
			(dBm)			Average	Average		
						(dBm)	(mW)		
5.0MHz Band 16 QAM	1/#Mid	2502.5	-0.48	4.54	27.75	22.73	187.499	Horizontal	Pass
		2535	-0.17	4.69	27.72	22.86	193.197	Horizontal	Pass
		2567.5	-0.25	4.71	27.71	22.75	188.365	Horizontal	Pass
10.0MHz Band 16 QAM	1/#Mid	2505	-0.37	4.55	27.76	22.84	192.309	Horizontal	Pass
		2535	-0.38	4.69	27.72	22.65	184.077	Horizontal	Pass
		2565	-0.65	4.72	27.70	22.33	171.002	Horizontal	Pass
15.0MHz Band 16 QAM	1/#Mid	2507.5	-0.55	4.55	27.77	22.67	184.927	Horizontal	Pass
		2535	-0.52	4.69	27.72	22.51	178.238	Horizontal	Pass
		2562.5	-0.13	4.72	27.69	22.84	192.309	Horizontal	Pass
20.0MHz Band 16 QAM	1/#Mid	2510	-0.43	4.57	27.78	22.78	189.671	Horizontal	Pass
		2535	-0.10	4.73	27.72	22.89	194.536	Horizontal	Pass
		2560	-0.20	4.75	27.68	22.73	187.499	Horizontal	Pass
5.0MHz Band 16 QAM	1/#Mid	2502.5	-2.49	4.54	27.75	20.72	118.032	Vertical	Pass
		2535	-0.72	4.69	27.72	22.31	170.216	Vertical	Pass
		2567.5	-1.30	4.71	27.71	21.70	147.911	Vertical	Pass
10.0MHz Band 16 QAM	1/#Mid	2505	-2.42	4.55	27.76	20.79	119.950	Vertical	Pass
		2535	-1.86	4.69	27.72	21.17	130.918	Vertical	Pass
		2565	-0.51	4.72	27.70	22.47	176.604	Vertical	Pass
15.0MHz Band 16 QAM	1/#Mid	2507.5	-0.65	4.55	27.77	22.57	180.717	Vertical	Pass
		2535	-1.56	4.69	27.72	21.47	140.281	Vertical	Pass
		2562.5	-1.37	4.72	27.69	21.60	144.544	Vertical	Pass
20.0MHz Band 16 QAM	1/#Mid	2510	-1.26	4.57	27.78	21.95	156.675	Vertical	Pass
		2535	-1.52	4.73	27.72	21.47	140.281	Vertical	Pass
		2560	-1.92	4.75	27.68	21.01	126.183	Vertical	Pass

Note:

SG Level= Signal generator output

Max. EIRP Average (dBm)= Antenna Gain(dB)+ SG Level (dBm)- Cable Loss(dBm)

8.6 LTE BAND 17

Radiated Power (ERP) for Band 17											
Mode	RB/RB SIZE	Frequency	Result							Polarization Of Max. ERP	Conclusion
			SG Level (dBm)	Cable Loss (dBm)	Antenna Gain (dB)	Correction (dB)	Max. EIRP Average (dBm)	Max. EIRP Average (mW)			
5.0MHz Band QPSK	1/#Mid	706.5	8.72	1.91	19.23	2.15	23.89	244.906	Vertical	Pass	
		710	8.58	1.91	19.26	2.15	23.78	238.781	Vertical	Pass	
		713.5	8.48	1.92	19.33	2.15	23.74	236.592	Vertical	Pass	
10.0MHz Band QPSK	1/#Mid	709	8.73	1.91	19.25	2.15	23.92	246.604	Vertical	Pass	
		710	8.68	1.91	19.26	2.15	23.88	244.343	Vertical	Pass	
		711	8.64	1.92	19.32	2.15	23.89	244.906	Vertical	Pass	
5.0MHz Band QPSK	1/#Mid	706.5	6.86	1.91	19.23	2.15	22.03	159.588	Horizontal	Pass	
		710	7.86	1.91	19.26	2.15	23.06	202.302	Horizontal	Pass	
		713.5	8.21	1.92	19.33	2.15	23.47	222.331	Horizontal	Pass	
10.0MHz Band QPSK	1/#Mid	709	6.57	1.91	19.25	2.15	21.76	149.968	Horizontal	Pass	
		710	7.73	1.91	19.26	2.15	22.93	196.336	Horizontal	Pass	
		711	6.90	1.92	19.32	2.15	22.15	164.059	Horizontal	Pass	

Radiated Power (ERP) for Band 17											
Mode	RB/RB SIZE	Frequency	Result							Polarization Of Max. ERP	Conclusion
			SG Level (dBm)	Cable Loss (dBm)	Antenna Gain (dB)	Correction (dB)	Max. EIRP	Max. EIRP			
					Average		Average				
					(dBm)		(mW)				
5.0MHz Band 16 QAM	1/#Mid	706.5	8.07	1.91	19.23	2.15	23.24	210.863	Vertical	Pass	
		710	7.98	1.91	19.26	2.15	23.18	207.970	Vertical	Pass	
		713.5	7.78	1.92	19.33	2.15	23.04	201.372	Vertical	Pass	
10.0MHz Band 16 QAM	1/#Mid	709	7.61	1.91	19.25	2.15	22.80	190.546	Vertical	Pass	
		710	8.14	1.91	19.26	2.15	23.34	215.774	Vertical	Pass	
		711	7.87	1.92	19.32	2.15	23.12	205.116	Vertical	Pass	
5.0MHz Band 16 QAM	1/#Mid	706.5	6.95	1.91	19.23	2.15	22.12	162.930	Horizontal	Pass	
		710	7.36	1.91	19.26	2.15	22.56	180.302	Horizontal	Pass	
		713.5	7.05	1.92	19.33	2.15	22.31	170.216	Horizontal	Pass	
10.0MHz Band 16 QAM	1/#Mid	709	6.97	1.91	19.25	2.15	22.16	164.437	Horizontal	Pass	
		710	6.82	1.91	19.26	2.15	22.02	159.221	Horizontal	Pass	
		711	6.82	1.92	19.32	2.15	22.07	161.065	Horizontal	Pass	

Note:

ERP=EIRP-2.15

SG Level= Signal generator output

Max. EIRP Average (dBm)= Antenna Gain(dB)+ SG Level (dBm)- Cable Loss(dBm)

9. SPURIOUS RADIATION EMISSION

RULE PART(S)

FCC: §2.1051, §22.917(a), §24.238(a), §27.53(c)(g)(h)(m)

LIMIT

For Band 7, the minimum permissible attenuation level of any spurious emission is $55 + \log_{10}(P)$ [Watts].

The minimum permissible attenuation level of any spurious emission is $43 + \log_{10}(P)$ [Watts], where P is the transmitter power in Watts.

TEST PROCEDURE

For Cellular equipment - Compliance with these rules is based on the use of measurement instrumentation employing a resolution bandwidth of 100 kHz or greater. In the 1 MHz bands immediately outside and adjacent to the frequency block a resolution bandwidth of at least one percent of the emission bandwidth of the fundamental emission of the transmitter may be employed. A narrower resolution bandwidth is permitted in all cases to improve measurement accuracy provided the measured power is integrated over the full required measurement bandwidth (i.e. 100 kHz or 1 percent of emission bandwidth, as specified). The emission bandwidth is defined as the width of the signal between two points, one below the carrier center frequency and one above the carrier center frequency, outside of which all emissions are attenuated at least 26 dB below the transmitter power.

For PCS equipment - Compliance with these rules is based on the use of measurement instrumentation employing a resolution bandwidth of 1 MHz or greater. However, in the 1 MHz bands immediately outside and adjacent to the frequency block a resolution bandwidth of at least one percent of the emission bandwidth of the fundamental emission of the transmitter may be employed. A narrower resolution bandwidth is permitted in all cases to improve measurement accuracy provided the measured power is integrated over the full required measurement bandwidth (i.e. 1 MHz or 1 percent of emission bandwidth, as specified). The emission bandwidth is defined as the width of the signal between two points, one below the carrier center frequency and one above the carrier center frequency, outside of which all emissions are attenuated at least 26 dB below the transmitter power.

The unwanted emission power shall be measured with a resolution bandwidth of at least 1% of the occupied bandwidth in the 1 MHz band immediately outside and adjacent to the channel edge of the equipment. Beyond the 1 MHz band immediately outside the channel edge of the equipment, a resolution bandwidth of 1 MHz shall be employed. A narrower resolution bandwidth is allowed to be used provided that the measured power is integrated over the full required measurement bandwidth of 1 MHz or 1% of the occupied bandwidth as applicable.

The power of any unwanted emissions measured from the channel edge of the equipment shall be attenuated below the transmitter power, P (dBW), as follows:

- a. for base station and subscriber equipment, other than mobile subscriber equipment, the attenuation shall not be less than $43 + 10 \text{ Log}_{10}(p)$, dB; and
- b. for mobile subscriber equipment, the attenuation shall not be less than $43 + 10 \text{ Log}_{10}(p)$, dB at the channel edges and $55 + 10 \text{ Log}_{10}(p)$ at 5.5 MHz away and beyond the channel edges where p in (a) and (b) is the transmitter power measured in watts.

MODES TESTED

- LTE Band 2
LTE Band 4
- LTE Band 5
LTE Band 7
LTE Band 17

RESULTS

PASS

9.1 LTE BAND 2

QPSK EIRP POWER FOR LTE BAND 2 (1.4MHZ BANDWIDTH)

Test Results for Low Channel 1850.7MHz							
Frequency(MHz)	SG Level(dBm)	Cable Loss(dB)	Antenna Gain(dB)	Absolute Level(dBm)	Limit (dBm)	Margin(dBm)	Polarity
3701.4	-53.20	4.04	33.51	-23.73	-13	-10.73	Horizontal
3701.4	-45.76	4.04	33.51	-16.29	-13	-3.29	Vertical
5552.1	-50.73	5.24	35.84	-20.13	-13	-7.13	Vertical
5552.1	-51.36	5.24	35.84	-20.76	-13	-7.76	Horizontal
194.1	-39.58	1.43	16.02	-24.99	-13	-11.99	Vertical
412.7	-38.95	1.30	17.99	-22.26	-13	-9.26	Horizontal
Test Results for Mid Channel 1880MHz							
3760.0	-47.60	4.04	33.56	-18.08	-13	-5.08	Horizontal
3760.0	-47.25	4.04	33.56	-17.73	-13	-4.73	Vertical
5640.0	-48.67	5.24	35.91	-18.00	-13	-5.00	Vertical
5640.0	-50.79	5.24	35.91	-20.12	-13	-7.12	Horizontal
175.1	-38.52	1.62	16.97	-23.17	-13	-10.17	Vertical
426.6	-39.82	1.74	15.98	-25.59	-13	-12.59	Horizontal
Test Results for High Channel 1909.3MHz							
3818.6	-52.23	4.04	34.00	-22.27	-13	-9.27	Horizontal
3818.6	-44.83	4.04	34.00	-14.87	-13	-1.87	Vertical
5727.9	-45.87	5.24	36.04	-15.07	-13	-2.07	Vertical
5727.9	-52.22	5.24	36.04	-21.42	-13	-8.42	Horizontal
189.8	-36.86	1.42	17.29	-20.99	-13	-7.99	Vertical
300.0	-34.03	1.50	17.90	-17.62	-13	-4.62	Horizontal

QPSK EIRP POWER FOR LTE BAND 2 (20.0MHZ BANDWIDTH)

Test Results for Low Channel 1860MHz							
Frequency(MHz)	SG Level(dBm)	Cable Loss(dB)	Antenna Gain(dB)	Absolute Level(dBm)	Limit (dBm)	Margin(dBm)	Polarity
3720.0	-53.58	4.07	33.54	-24.11	-13	-11.11	Horizontal
3720.0	-48.88	4.07	33.54	-19.41	-13	-6.41	Vertical
5580.0	-50.31	5.28	35.86	-19.73	-13	-6.73	Vertical
5580.0	-52.62	5.28	35.86	-22.04	-13	-9.04	Horizontal
188.5	-41.39	1.58	16.89	-26.07	-13	-13.07	Vertical
467.2	-39.23	1.76	17.26	-23.73	-13	-10.73	Horizontal
Test Results for Mid Channel 1880MHz							
3760.0	-51.95	4.04	33.56	-22.43	-13	-9.43	Horizontal
3760.0	-49.58	4.04	33.56	-20.06	-13	-7.06	Vertical
5640.0	-50.79	5.24	35.91	-20.12	-13	-7.12	Vertical
5640.0	-50.79	5.24	35.91	-20.12	-13	-7.12	Horizontal
176.3	-38.76	1.46	16.27	-23.95	-13	-10.95	Vertical
265.6	-44.07	1.59	15.15	-30.51	-13	-17.51	Horizontal
Test Results for High Channel 1900MHz							
3800.0	-45.15	4.04	34.00	-15.19	-13	-2.19	Horizontal
3800.0	-51.26	4.04	34.00	-21.30	-13	-8.30	Vertical
5700.0	-51.32	5.24	36.04	-20.52	-13	-7.52	Vertical
5700.0	-50.30	5.24	36.04	-19.50	-13	-6.50	Horizontal
194.1	-35.19	1.36	17.39	-19.15	-13	-6.15	Vertical
469.0	-44.30	1.66	15.39	-30.57	-13	-17.57	Horizontal

Note: $P_{Mea}(dBm) = Power(dBm) + AR_{pl}(dBm)$

. Over Limit = $P_{Mea}(dBm) - Limit(dBm)$

. Both QPSK and 16QAM has been tested, the worst case is QPSK mode, the report just reported the worst case.

9.2 LTE BAND 4

QPSK EIRP POWER FOR LTE BAND 4 (1.4MHZ BANDWIDTH)

Test Results for Low Channel 1710.7MHz							
Frequency(MHz)	SG Level(dBm)	Cable Loss(dB)	Antenna Gain(dB)	Absolute Level(dBm)	Limit (dBm)	Margin(dBm)	Polarity
3421.4	-48.54	4.02	29.80	-22.76	-13	-9.76	Horizontal
3421.4	-51.22	4.02	29.80	-25.44	-13	-12.44	Vertical
5132.1	-52.93	5.24	35.84	-22.33	-13	-9.33	Vertical
5132.1	-52.05	5.24	35.84	-21.45	-13	-8.45	Horizontal
199.2	-37.59	1.68	16.04	-23.23	-13	-10.23	Vertical
397.3	-42.60	1.78	17.74	-26.64	-13	-13.64	Horizontal
Test Results for Mid Channel 1732.5MHz							
3465.0	-46.55	4.03	30.00	-20.58	-13	-7.58	Horizontal
3465.0	-49.55	4.03	30.00	-23.58	-13	-10.58	Vertical
5197.5	-52.85	5.25	35.86	-22.24	-13	-9.24	Vertical
5197.5	-51.10	5.25	35.86	-20.49	-13	-7.49	Horizontal
199.3	-35.66	1.72	17.69	-19.69	-13	-6.69	Vertical
327.4	-40.84	1.62	16.02	-26.43	-13	-13.43	Horizontal
Test Results for High Channel 1754.3MHz							
3508.6	-50.06	4.05	30.01	-24.10	-13	-11.10	Horizontal
3508.6	-52.05	4.05	30.01	-26.09	-13	-13.09	Vertical
5262.9	-48.81	5.26	35.86	-18.21	-13	-5.21	Vertical
5262.9	-50.74	5.26	35.86	-20.14	-13	-7.14	Horizontal
177.8	-35.44	1.80	16.69	-20.55	-13	-7.55	Vertical
304.3	-39.21	1.75	16.66	-24.31	-13	-11.31	Horizontal

QPSK EIRP POWER FOR LTE BAND 4 (20.0MHZ BANDWIDTH)

Test Results for Low Channel 1720MHz							
Frequency(MHz)	SG Level(dBm)	Cable Loss(dB)	Antenna Gain(dB)	Absolute Level(dBm)	Limit (dBm)	Margin(dBm)	Polarity
3440.0	-53.65	4.02	29.80	-27.87	-13	-14.87	Horizontal
3440.0	-50.56	4.02	29.80	-24.78	-13	-11.78	Vertical
5160.0	-48.83	5.24	35.84	-18.23	-13	-5.23	Vertical
5160.0	-51.87	5.24	35.84	-21.27	-13	-8.27	Horizontal
191.0	-42.27	1.57	17.26	-26.58	-13	-13.58	Vertical
336.8	-39.33	1.78	16.35	-24.76	-13	-11.76	Horizontal
Test Results for Mid Channel 1732.5MHz							
3465.0	-47.89	4.03	30.00	-21.92	-13	-8.92	Horizontal
3465.0	-52.59	4.03	30.00	-26.62	-13	-13.62	Vertical
5197.5	-44.77	5.25	35.86	-14.16	-13	-1.16	Vertical
5197.5	-52.45	5.25	35.86	-21.84	-13	-8.84	Horizontal
179.0	-38.49	1.44	17.95	-21.98	-13	-8.98	Vertical
414.7	-44.62	1.65	16.09	-30.18	-13	-17.18	Horizontal
Test Results for High Channel 1745MHz							
3490.0	-52.57	2.91	27.68	-27.80	-13	-14.80	Horizontal
3490.0	-48.42	2.91	27.68	-23.65	-13	-10.65	Vertical
5235.0	-53.99	5.26	35.86	-23.39	-13	-10.39	Vertical
5235.0	-49.28	5.26	35.86	-18.68	-13	-5.68	Horizontal
204.2	-44.93	1.61	16.85	-29.69	-13	-16.69	Vertical
429.2	-44.44	1.61	15.19	-30.86	-13	-17.86	Horizontal

Note: $P_{Mea}(dBm) = Power(dBm) + ARpl(dBm)$

Over Limit = $P_{Mea}(dBm) - Limit(dBm)$

Both QPSK and 16QAM has been tested, the worst case is QPSK mode, the report just reported the worst case.

9.3 LTE BAND 5

QPSK EIRP POWER FOR LTE BAND 5 (1.4MHZ BANDWIDTH)

Test Results for Low Channel 824.7MHz							
Frequency(MHz)	SG Level(dBm)	Cable Loss(dB)	Antenna Gain(dB)	Absolute Level(dBm)	Limit (dBm)	Margin(dBm)	Polarity
1649.4	-45.22	2.78	27.50	-20.50	-13	-7.50	Horizontal
1649.4	-47.83	2.78	27.50	-23.11	-13	-10.11	Vertical
2474.1	-44.16	2.90	27.80	-19.26	-13	-6.26	Vertical
2474.1	-52.60	2.90	27.80	-27.70	-13	-14.70	Horizontal
194.7	-43.19	1.76	17.59	-27.36	-13	-14.36	Vertical
338.3	-35.97	1.63	15.87	-21.73	-13	-8.73	Horizontal
Test Results For Mid Channel 836.5MHz							
1673.0	-53.22	2.80	27.48	-28.54	-13	-15.54	Horizontal
1673.0	-46.10	2.80	27.48	-21.42	-13	-8.42	Vertical
2509.5	-50.70	2.91	27.70	-25.91	-13	-12.91	Vertical
2509.5	-51.14	2.91	27.70	-26.35	-13	-13.35	Horizontal
177.3	-36.37	1.61	15.68	-22.30	-13	-9.30	Vertical
392.4	-41.35	1.59	17.52	-25.43	-13	-12.43	Horizontal
Test Results for High Channel 848.3MHz							
1696.6	-48.63	2.82	27.43	-24.02	-13	-11.02	Horizontal
1696.6	-52.18	2.82	27.43	-27.57	-13	-14.57	Vertical
2544.9	-49.29	2.92	27.74	-24.47	-13	-11.47	Vertical
2544.9	-50.20	2.92	27.74	-25.38	-13	-12.38	Horizontal
206.9	-37.11	1.69	16.67	-22.12	-13	-9.12	Vertical
311.6	-34.14	1.70	17.18	-18.66	-13	-5.66	Horizontal

QPSK EIRP POWER FOR LTE BAND 5 (10MHZ BANDWIDTH)

Test Results for Low Channel 829MHz							
Frequency(MHz)	SG Level(dBm)	Cable Loss(dB)	Antenna Gain(dB)	Absolute Level(dBm)	Limit (dBm)	Margin(dBm)	Polarity
1658.0	-47.52	2.78	27.50	-22.80	-13	-9.80	Horizontal
1658.0	-46.88	2.78	27.50	-22.16	-13	-9.16	Vertical
2487.0	-49.05	2.90	27.80	-24.15	-13	-11.15	Vertical
2487.0	-49.65	2.90	27.80	-24.75	-13	-11.75	Horizontal
193.9	-42.97	1.71	15.57	-29.11	-13	-16.11	Vertical
317.2	-44.76	1.34	16.40	-29.70	-13	-16.70	Horizontal
Test Results for Mid Channel 836.5MHz							
1673.0	-46.14	2.80	27.48	-21.46	-13	-8.46	Horizontal
1673.0	-48.77	2.80	27.48	-24.09	-13	-11.09	Vertical
2509.5	-49.76	2.91	27.70	-24.97	-13	-11.97	Vertical
2509.5	-49.33	2.91	27.70	-24.54	-13	-11.54	Horizontal
204.3	-41.85	1.44	17.04	-26.25	-13	-13.25	Vertical
334.3	-34.86	1.76	17.62	-19.00	-13	-6.00	Horizontal
Test Results for High Channel 844MHz							
1688.0	-47.79	2.82	27.43	-23.18	-13	-10.18	Horizontal
1688.0	-51.66	2.82	27.43	-27.05	-13	-14.05	Vertical
2532.0	-51.62	2.92	27.74	-26.80	-13	-13.80	Vertical
2532.0	-50.73	2.92	27.74	-25.91	-13	-12.91	Horizontal
204.9	-38.06	1.74	17.70	-22.10	-13	-9.10	Vertical
291.0	-40.81	1.41	17.46	-24.75	-13	-11.75	Horizontal

Note: $P_{Mea}(dBm) = Power(dBm) + ARpl (dBm)$

. Over Limit = $P_{Mea}(dBm) - Limit(dBm)$

. Both QPSK and 16QAM has been tested, the worst case is QPSK mode, the report just reported the worst case.

9.4 LTE BAND 7

QPSK EIRP POWER FOR LTE BAND 7 (5.0MHZ BANDWIDTH)

Test Results for Low Channel 2502.5MHz							
Frequency(MHz)	SG Level(dBm)	Cable Loss(dB)	Antenna Gain(dB)	Absolute Level(dBm)	Limit (dBm)	Margin(dBm)	Polarity
5005.0	-59.05	5.23	35.81	-28.47	-25	-3.47	Horizontal
5005.0	-59.27	5.23	35.81	-28.69	-25	-3.69	Vertical
7507.5	-64.67	5.67	36.85	-33.49	-25	-8.49	Vertical
7507.5	-59.25	5.67	36.85	-28.07	-25	-3.07	Horizontal
206.3	-49.06	1.73	17.97	-32.82	-25	-7.82	Vertical
466.9	-48.50	1.38	15.11	-34.77	-25	-9.77	Horizontal
Test Results for Mid Channel 2535MHz							
5070.0	-64.85	5.23	35.82	-34.26	-25	-9.26	Horizontal
5070.0	-61.10	5.23	35.82	-30.51	-25	-5.51	Vertical
7605.0	-59.44	5.67	36.85	-28.26	-25	-3.26	Vertical
7605.0	-62.38	5.67	36.85	-31.20	-25	-6.20	Horizontal
190.8	-44.77	1.77	16.17	-30.36	-25	-5.36	Vertical
245.0	-54.45	1.63	15.21	-40.87	-25	-15.87	Horizontal
Test Results for High Channel 2567.5MHz							
5135.0	-62.22	5.24	35.83	-31.63	-25	-6.63	Horizontal
5135.0	-60.82	5.24	35.83	-30.23	-25	-5.23	Vertical
7702.5	-64.99	5.68	36.87	-33.80	-25	-8.80	Vertical
7702.5	-62.09	5.68	36.87	-30.90	-25	-5.90	Horizontal
175.8	-44.58	1.58	17.56	-28.60	-25	-3.60	Vertical
353.1	-45.11	1.45	16.58	-29.98	-25	-4.98	Horizontal

QPSK EIRP POWER FOR LTE BAND 7 (20.0MHZ BANDWIDTH)

Test Results for Low Channel 2510MHz							
Frequency(MHz)	SG Level(dBm)	Cable Loss(dB)	Antenna Gain(dB)	Absolute Level(dBm)	Limit (dBm)	Margin(dBm)	Polarity
5020.0	-59.51	5.23	35.82	-28.92	-25	-3.92	Horizontal
5020.0	-62.18	5.23	35.82	-31.59	-25	-6.59	Vertical
7530.0	-59.64	5.67	36.86	-28.45	-25	-3.45	Vertical
7530.0	-64.91	5.67	36.86	-33.72	-25	-8.72	Horizontal
198.2	-47.61	1.63	15.76	-33.48	-25	-8.48	Vertical
450.5	-52.43	1.71	15.44	-38.70	-25	-13.70	Horizontal
Test Results for Mid Channel 2535MHz							
5070.0	-64.22	5.23	35.82	-33.63	-25	-8.63	Horizontal
5070.0	-59.93	5.23	35.82	-29.34	-25	-4.34	Vertical
7605.0	-64.19	5.67	36.85	-33.01	-25	-8.01	Vertical
7605.0	-64.07	5.67	36.85	-32.89	-25	-7.89	Horizontal
189.6	-50.60	1.79	16.84	-35.54	-25	-10.54	Vertical
375.1	-47.15	1.71	17.64	-31.22	-25	-6.22	Horizontal
Test Results for High Channel 2560MHz							
5120.0	-62.58	5.24	35.83	-31.99	-25	-6.99	Horizontal
5120.0	-59.51	5.24	35.83	-28.92	-25	-3.92	Vertical
7680.0	-60.14	5.70	36.88	-28.96	-25	-3.96	Vertical
7680.0	-63.31	5.70	36.88	-32.13	-25	-7.13	Horizontal
184.9	-47.64	1.79	16.84	-32.58	-25	-7.58	Vertical
318.9	-47.68	1.71	17.64	-31.75	-25	-6.75	Horizontal

Note: P_{Mea}(dBm)= Power(dBm)+ AR_{pl} (dBm)

. Over Limit= : P_{Mea}(dBm)-Limit(dBm)

. Both QPSK and 16QAM has been tested, the worst case is QPSK mode, the report just reported the worst case.

9.5 LTE BAND 17

QPSK EIRP POWER FOR LTE BAND 17 (5MHZ BANDWIDTH)

Test Results for Low Channel 706.5MHz							
Frequency(MHz)	SG Level(dBm)	Cable Loss(dB)	Antenna Gain(dB)	Absolute Level(dBm)	Limit (dBm)	Margin(dBm)	Polarity
1413.0	-51.07	2.61	27.28	-26.40	-13	-13.40	Horizontal
1413.0	-49.55	2.61	27.28	-24.88	-13	-11.88	Vertical
2119.5	-46.35	2.87	27.59	-21.63	-13	-8.63	Vertical
2119.5	-50.22	2.87	27.59	-25.50	-13	-12.50	Horizontal
182.8	-43.55	1.71	16.15	-29.11	-13	-16.11	Vertical
407.8	-44.93	1.41	17.32	-29.02	-13	-16.02	Horizontal
Test Results For Mid Channel 710MHz							
1420.0	-50.66	2.62	27.30	-25.98	-13	-12.98	Horizontal
1420.0	-48.91	2.62	27.30	-24.23	-13	-11.23	Vertical
2130.0	-50.73	2.87	27.62	-25.98	-13	-12.98	Vertical
2130.0	-53.37	2.87	27.62	-28.62	-13	-15.62	Horizontal
197.8	-37.83	1.42	15.25	-24.01	-13	-11.01	Vertical
400.3	-41.97	1.36	17.19	-26.14	-13	-13.14	Horizontal
Test Results for High Channel 713.5MHz							
1427.0	-47.32	2.66	27.28	-22.70	-13	-9.70	Horizontal
1427.0	-52.54	2.66	27.28	-27.92	-13	-14.92	Vertical
2140.5	-53.33	2.88	27.60	-28.61	-13	-15.61	Vertical
2140.5	-53.53	2.88	27.60	-28.81	-13	-15.81	Horizontal
192.9	-42.35	1.32	17.29	-26.38	-13	-13.38	Vertical
350.6	-44.32	1.72	16.89	-29.15	-13	-16.15	Horizontal

QPSK EIRP POWER FOR LTE BAND 17 (10MHZ BANDWIDTH)

Test Results for Low Channel 709MHz							
Frequency(MHz)	SG Level(dBm)	Cable Loss(dB)	Antenna Gain(dB)	Absolute Level(dBm)	Limit (dBm)	Margin(dBm)	Polarity
1418.0	-47.68	2.62	27.30	-23.00	-13	-10.00	Horizontal
1418.0	-51.85	2.62	27.30	-27.17	-13	-14.17	Vertical
2127.0	-46.44	2.87	27.62	-21.69	-13	-8.69	Vertical
2127.0	-53.77	2.87	27.62	-29.02	-13	-16.02	Horizontal
196.4	-41.97	1.35	16.91	-26.41	-13	-13.41	Vertical
277.4	-38.35	1.62	16.31	-23.66	-13	-10.66	Horizontal
Test Results for Mid Channel 710MHz							
1420.0	-48.26	2.62	27.30	-23.58	-13	-10.58	Horizontal
1420.0	-47.33	2.62	27.30	-22.65	-13	-9.65	Vertical
2130.0	-48.49	2.87	27.62	-23.74	-13	-10.74	Vertical
2130.0	-50.80	2.87	27.62	-26.05	-13	-13.05	Horizontal
187.0	-34.41	1.51	17.14	-18.78	-13	-5.78	Vertical
259.8	-36.88	1.77	16.88	-21.77	-13	-8.77	Horizontal
Test Results for High Channel 711MHz							
1422.0	-53.76	2.62	27.30	-29.08	-13	-16.08	Horizontal
1422.0	-45.28	2.62	27.30	-20.60	-13	-7.60	Vertical
2133.0	-51.57	2.87	27.62	-26.82	-13	-13.82	Vertical
2133.0	-53.80	2.87	27.62	-29.05	-13	-16.05	Horizontal
191.7	-43.27	1.78	15.95	-29.10	-13	-16.10	Vertical
450.0	-43.65	1.34	17.95	-27.05	-13	-14.05	Horizontal

Note: P_{Mea}(dBm)= Power(dBm)+ AR_{pl} (dBm)

Over Limit= : P_{Mea}(dBm)-Limit(dBm)

Both QPSK and 16QAM has been tested, the worst case is QPSK mode, the report just reported the worst case.

10. FREQUENCY STABILITY

RULE PART(S)

FCC: §2.1055, §22.355, §24.235, §27.54

LIMITS

§22.355 - The carrier frequency shall not depart from the reference frequency in excess of ± 2.5 ppm for mobile stations.

§24.235 - The frequency stability shall be sufficient to ensure that the fundamental emission stays within the authorized frequency block.

TEST PROCEDURE

Use CMW 500 with Frequency Error measurement capability.

- Temp. = -30° to $+50^{\circ}\text{C}$
- Voltage = low voltage, DC 3.4V, Normal, DC 3.8V and High voltage, DC 4.2V.

Frequency Stability vs Temperature:

The EUT is placed inside a temperature chamber. The temperature is set to -30°C and allowed to stabilize. After sufficient soak time, the transmitting frequency error is measured. The temperature is increased by 10 degrees, allowed to stabilize and soak, and then the measurement is repeated. This is repeated until $+50^{\circ}\text{C}$ is reached.

Frequency Stability vs Voltage:

The peak frequency error is recorded (worst-case).

MODES TESTED

- LTE Band 2
LTE Band 4
- LTE Band 5
LTE Band 7
LTE Band 17

RESULTS

See the following pages.

10.1 LTE BAND 2

Band 2 QPSK, (20MHz BANDWIDTH RB size 100 RB Offset 0)

Frequency error vs. Voltage

Voltage [Vdc]	Frequency [MHz]	Frequency* Error[Hz]	Frequency Error[ppm]	Limit [ppm]
3.4	1880	12.3	0.006561	2.5
3.8	1880	14.2	0.007560	2.5
4.2	1880	13.5	0.007192	2.5

Frequency error vs. Temperature

Temperature [°C]	Frequency [MHz]	Frequency* Error[Hz]	Frequency Error[ppm]	Limit [ppm]
Normal (25C)	1880	13.0	0.006935	2.5
Extreme (50C)	1880	11.5	0.006095	2.5
Extreme (40C)	1880	13.8	0.007332	2.5
Extreme (30C)	1880	13.2	0.007035	2.5
Extreme (10C)	1880	13.6	0.007236	2.5
Extreme (0C)	1880	12.3	0.006552	2.5
Extreme (-10C)	1880	12.6	0.006680	2.5
Extreme (-20C)	1880	14.4	0.007685	2.5
Extreme (-30C)	1880	14.9	0.007905	2.5

Band 2 16QAM, (20MHz BANDWIDTH RB size 100 RB Offset 0)

Frequency error vs. Voltage

Voltage [Vdc]	Frequency [MHz]	Frequency* Error[Hz]	Frequency Error[ppm]	Limit [ppm]
3.4	1880	9.7	0.005183	2.5
3.8	1880	8.5	0.004532	2.5
4.2	1880	8.2	0.004353	2.5

Frequency error vs. Temperature

Temperature [°C]	Frequency [MHz]	Frequency* Error[Hz]	Frequency Error[ppm]	Limit [ppm]
Normal (25C)	1880	9.3	0.004924	2.5
Extreme (50C)	1880	8.9	0.004758	2.5
Extreme (40C)	1880	8.6	0.004556	2.5
Extreme (30C)	1880	8.6	0.004575	2.5
Extreme (10C)	1880	9.2	0.004876	2.5
Extreme (0C)	1880	8.3	0.004409	2.5
Extreme (-10C)	1880	8.8	0.004670	2.5
Extreme (-20C)	1880	9.1	0.004820	2.5
Extreme (-30C)	1880	8.1	0.004323	2.5

***Note:** Frequency error measurements were made by using the build-in capability of the Wireless Communication Test Set.

10.2 LTE BAND 4

Band 4 QPSK, (20MHz BANDWIDTH RB size 100 RB Offset 0)

Frequency error vs. Voltage

Voltage [Vdc]	Frequency [MHz]	Frequency* Error[Hz]	Frequency Error[ppm]	Limit [ppm]
3.4	1732.5	8.9	0.005123	2.5
3.8	1732.5	9.1	0.005253	2.5
4.2	1732.5	8.4	0.004824	2.5

Frequency error vs. Temperature

Temperature [°C]	Frequency [MHz]	Frequency* Error[Hz]	Frequency Error[ppm]	Limit [ppm]
Normal (25C)	1732.5	8.8	0.005079	2.5
Extreme (50C)	1732.5	9.3	0.005371	2.5
Extreme (40C)	1732.5	7.5	0.004349	2.5
Extreme (30C)	1732.5	5.9	0.003422	2.5
Extreme (10C)	1732.5	7.2	0.004161	2.5
Extreme (0C)	1732.5	9.8	0.005634	2.5
Extreme (-10C)	1732.5	8.4	0.004849	2.5
Extreme (-20C)	1732.5	6.5	0.003733	2.5
Extreme (-30C)	1732.5	8.7	0.005000	2.5

Band 4 16QAM, (20MHz BANDWIDTH RB size 100 RB Offset 0)

Frequency error vs. Voltage

Voltage [Vdc]	Frequency [MHz]	Frequency* Error[Hz]	Frequency Error[ppm]	Limit [ppm]
3.4	1732.5	9.8	0.005644	2.5
3.8	1732.5	9.3	0.005342	2.5
4.2	1732.5	8.5	0.004917	2.5

Frequency error vs. Temperature

Temperature [°C]	Frequency [MHz]	Frequency* Error[Hz]	Frequency Error[ppm]	Limit [ppm]
Normal (25C)	1732.5	9.6	0.005514	2.5
Extreme (50C)	1732.5	8.4	0.004851	2.5
Extreme (40C)	1732.5	8.6	0.004942	2.5
Extreme (30C)	1732.5	8.8	0.005101	2.5
Extreme (10C)	1732.5	8.6	0.004952	2.5
Extreme (0C)	1732.5	8.1	0.004664	2.5
Extreme (-10C)	1732.5	9.2	0.005291	2.5
Extreme (-20C)	1732.5	9.3	0.005364	2.5
Extreme (-30C)	1732.5	8.3	0.004818	2.5

***Note:** Frequency error measurements were made by using the build-in capability of the Wireless Communication Test Set.

10.3 LTE BAND 5

Band 5 QPSK, (10MHz BANDWIDTH RB size 50 RB Offset 0)

Frequency error vs. Voltage

Voltage [Vdc]	Frequency [MHz]	Frequency* Error[Hz]	Frequency Error[ppm]	Limit [ppm]
3.4	836.5	5.4	0.006464	2.5
3.8	836.5	6.8	0.008079	2.5
4.2	836.5	4.8	0.005709	2.5

Frequency error vs. Temperature

Temperature [°C]	Frequency [MHz]	Frequency* Error[Hz]	Frequency Error[ppm]	Limit [ppm]
Normal (25C)	836.5	5.9	0.007066	2.5
Extreme (50C)	836.5	5.8	0.006934	2.5
Extreme (40C)	836.5	5.9	0.007099	2.5
Extreme (30C)	836.5	6.1	0.007312	2.5
Extreme (10C)	836.5	5.9	0.007016	2.5
Extreme (0C)	836.5	5.1	0.006051	2.5
Extreme (-10C)	836.5	5.2	0.006228	2.5
Extreme (-20C)	836.5	5.9	0.007029	2.5
Extreme (-30C)	836.5	6.3	0.007544	2.5

Band 5 16QAM, (10MHz BANDWIDTH RB size 50 RB Offset 0)

Frequency error vs. Voltage

Voltage [Vdc]	Frequency [MHz]	Frequency* Error[Hz]	Frequency Error[ppm]	Limit [ppm]
3.4	836.5	5.4	0.006457	2.5
3.8	836.5	6.7	0.008022	2.5
4.2	836.5	5.0	0.005992	2.5

Frequency error vs. Temperature

Temperature [°C]	Frequency [MHz]	Frequency* Error[Hz]	Frequency Error[ppm]	Limit [ppm]
Normal (25C)	836.5	5.9	0.007001	2.5
Extreme (50C)	836.5	6.2	0.007419	2.5
Extreme (40C)	836.5	5.8	0.006972	2.5
Extreme (30C)	836.5	6.2	0.007433	2.5
Extreme (10C)	836.5	5.8	0.006919	2.5
Extreme (0C)	836.5	4.8	0.005752	2.5
Extreme (-10C)	836.5	5.2	0.006254	2.5
Extreme (-20C)	836.5	6.0	0.007156	2.5
Extreme (-30C)	836.5	6.2	0.007412	2.5

***Note:** Frequency error measurements were made by using the build-in capability of the Wireless Communication Test Set.

10.4 LTE BAND 7

Band 7 QPSK, (20MHz BANDWIDTH RB size 100 RB Offset 0)

Frequency error vs. Voltage

Voltage [Vdc]	Frequency [MHz]	Frequency* Error[Hz]	Frequency Error[ppm]	Limit [ppm]
3.4	2535	10.4	0.004112	2.5
3.8	2535	8.5	0.003359	2.5
4.2	2535	8.5	0.003334	2.5

Frequency error vs. Temperature

Temperature [°C]	Frequency [MHz]	Frequency* Error[Hz]	Frequency Error[ppm]	Limit [ppm]
Normal (25C)	2535	9.4	0.003717	2.5
Extreme (50C)	2535	8.8	0.003467	2.5
Extreme (40C)	2535	8.2	0.003253	2.5
Extreme (30C)	2535	8.6	0.003374	2.5
Extreme (10C)	2535	7.8	0.003096	2.5
Extreme (0C)	2535	8.7	0.003450	2.5
Extreme (-10C)	2535	9.4	0.003692	2.5
Extreme (-20C)	2535	9.3	0.003659	2.5
Extreme (-30C)	2535	8.7	0.003428	2.5

Band 7 16QAM, (20MHz BANDWIDTH RB size 100 RB Offset 0)

Frequency error vs. Voltage

Voltage [Vdc]	Frequency [MHz]	Frequency* Error[Hz]	Frequency Error[ppm]	Limit [ppm]
3.4	2535	6.9	0.002722	2.5
3.8	2535	6.8	0.002684	2.5
4.2	2535	6.1	0.002399	2.5

Frequency error vs. Temperature

Temperature [°C]	Frequency [MHz]	Frequency* Error[Hz]	Frequency Error[ppm]	Limit [ppm]
Normal (25C)	2535	6.9	0.002722	2.5
Extreme (50C)	2535	5.7	0.002237	2.5
Extreme (40C)	2535	5.6	0.002204	2.5
Extreme (30C)	2535	6.5	0.002563	2.5
Extreme (10C)	2535	5.8	0.002305	2.5
Extreme (0C)	2535	5.2	0.002045	2.5
Extreme (-10C)	2535	5.5	0.002179	2.5
Extreme (-20C)	2535	6.1	0.002409	2.5
Extreme (-30C)	2535	5.3	0.002107	2.5

***Note:** Frequency error measurements were made by using the build-in capability of the Wireless Communication Test Set.

10.5 LTE BAND 17

Band 17 QPSK, (10MHz BANDWIDTH RB size 50 RB Offset 0)

Frequency error vs. Voltage

Voltage [Vdc]	Frequency [MHz]	Frequency* Error[Hz]	Frequency Error[ppm]	Limit [ppm]
3.4	710	10.2	0.014354	2.5
3.8	710	8.4	0.011884	2.5
4.2	710	8.1	0.011412	2.5

Frequency error vs. Temperature

Temperature [°C]	Frequency [MHz]	Frequency* Error[Hz]	Frequency Error[ppm]	Limit [ppm]
Normal (25C)	710	9.2	0.012988	2.5
Extreme (50C)	710	9.3	0.013162	2.5
Extreme (40C)	710	7.9	0.011078	2.5
Extreme (30C)	710	8.8	0.012460	2.5
Extreme (10C)	710	9.0	0.012665	2.5
Extreme (0C)	710	8.1	0.011414	2.5
Extreme (-10C)	710	9.1	0.012841	2.5
Extreme (-20C)	710	9.1	0.012879	2.5
Extreme (-30C)	710	7.8	0.010958	2.5

Band 17 16QAM, (10MHz BANDWIDTH RB size 50 RB Offset 0)

Frequency error vs. Voltage

Voltage [Vdc]	Frequency [MHz]	Frequency* Error[Hz]	Frequency Error[ppm]	Limit [ppm]
3.4	710	9.9	0.013974	2.5
3.8	710	9.3	0.013127	2.5
4.2	710	8.8	0.012357	2.5

Frequency error vs. Temperature

Temperature [°C]	Frequency [MHz]	Frequency* Error[Hz]	Frequency Error[ppm]	Limit [ppm]
Normal (25C)	710	9.8	0.013774	2.5
Extreme (50C)	710	8.9	0.012510	2.5
Extreme (40C)	710	8.1	0.011351	2.5
Extreme (30C)	710	9.3	0.013163	2.5
Extreme (10C)	710	8.2	0.011618	2.5
Extreme (0C)	710	7.9	0.011142	2.5
Extreme (-10C)	710	9.7	0.013645	2.5
Extreme (-20C)	710	8.7	0.012289	2.5
Extreme (-30C)	710	8.8	0.012425	2.5

***Note:** Frequency error measurements were made by using the build-in capability of the Wireless Communication Test Set.

11. Peak-to-Average Ratio

11.1 Description of the PAR Measurement

The peak-to-average ratio (PAR) of the transmission may not exceed 13 dB.

11.2 Measuring Instruments

See list of measuring instruments of this test report.

11.3 Test Procedures

1. The EUT was connected to Spectrum Analyzer and Base Station via power divider.
2. The RF output of EUT was connected to the spectrum analyzer by RF cable and attenuator. The path loss was compensated to the results for each measurement.
3. For LTE operating modes:
 - a. Set the CCDF (Complementary Cumulative Distribution Function) option in spectrum analyzer.
 - b. The highest RF powers were measured and recorded the maximum PAPR level associated with a probability of 0.1 %.

11.4 Test Setup

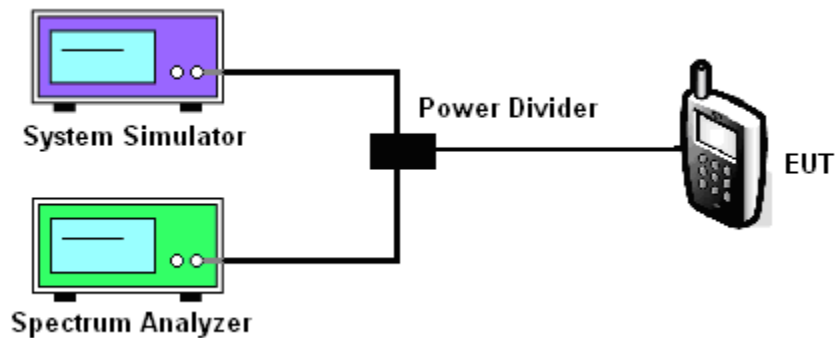

MODES TESTED

- LTE Band 2/4/5/7/17
-

Test data reference attachment.

----END OF REPORT----