

User Manual

# Azeyou

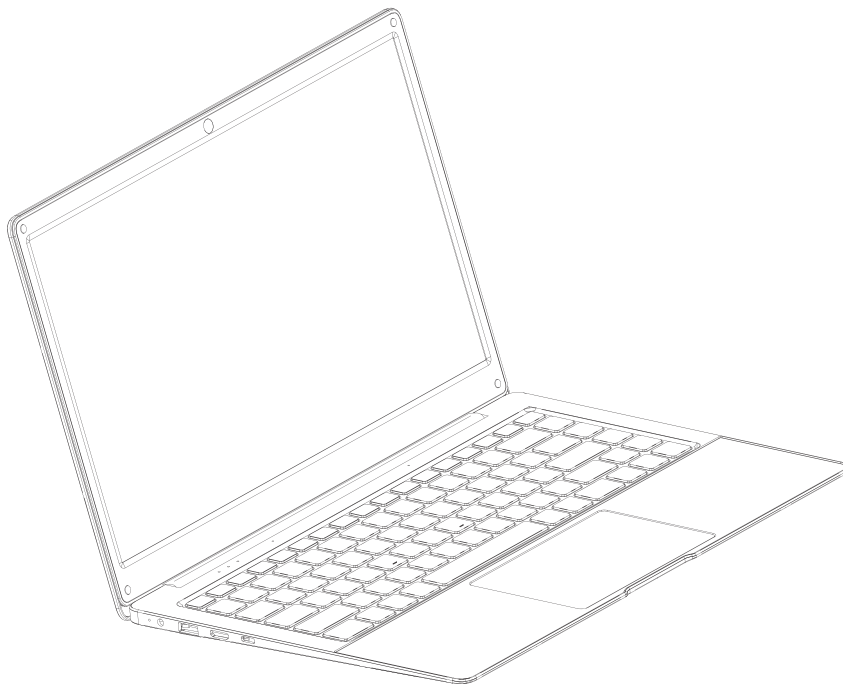

The pictures are for reference only, and the details shall be subject to the real object

15.6" U Series Laptop (8GB,128GB)

Model No.: AL151U

Please read this manual before operating your device  
and keep it for future reference.

# Important Safety Introduction

**Since the operation system updates regularly, the user manual may not cover all aspects of new features.**

We would like you to have a safe and enjoyable experience, please read the following instructions and notices before using your laptop.

1. The laptop is not moisture/water-resistant, please don't use it around sources of water.
2. Avoid using the laptop in extremely hot, cold, dusty, damp or wet environments.
3. Do not use alcohol, thinner or benzene to clean the laptop, use only cleaning products designed for computer tablet devices.
4. Do not drop or hit the laptop against a hard surface or the laptop may be damaged.
5. Avoid using the laptop in the strong magnetic and strong static environment.
6. Azeyou shall not be liable for any data loss, please back up your important data to prevent any such data loss.
7. Do not dismantle the laptop.
8. Do not use other accessories except specified or provided by the manufacturer(such as the power adapter, battery etc).

## What's In The Box

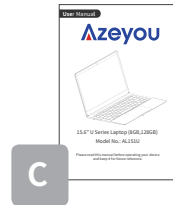
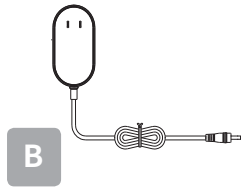
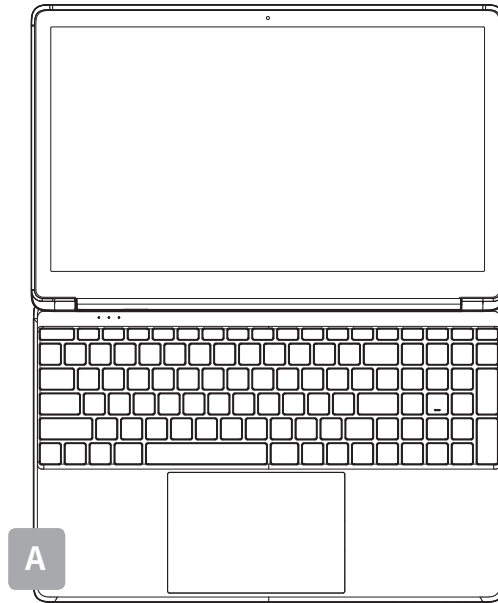

- A** Laptop
- B** Power adapter
- C** User manual

# Overview

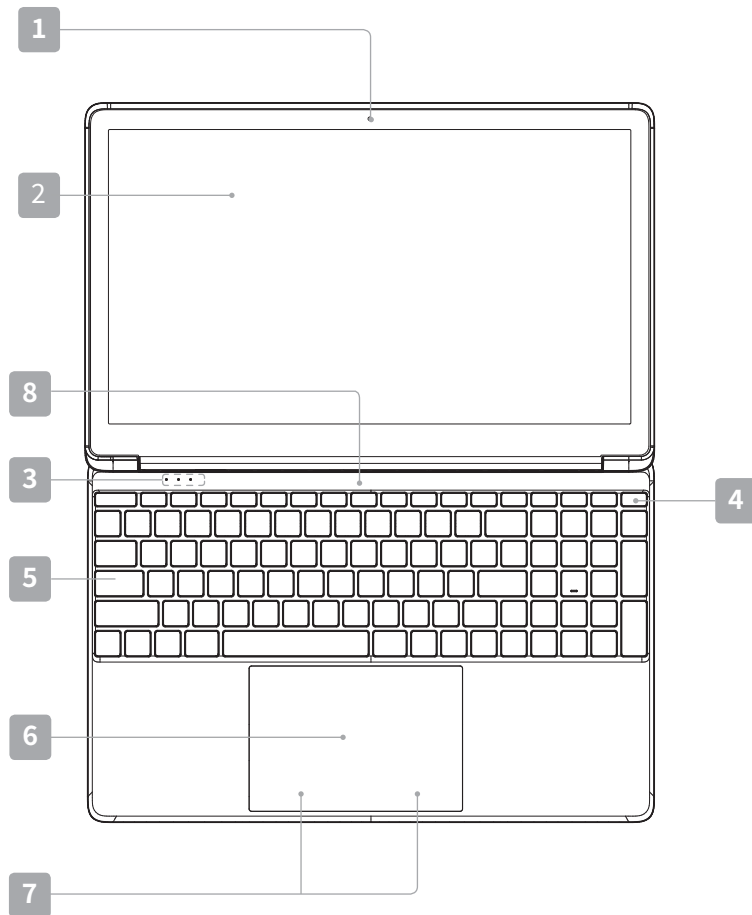

- |                      |                               |
|----------------------|-------------------------------|
| 1 Camera             | 5 Keyboard                    |
| 2 Display            | 6 Trackpad                    |
| 3 Indicator lights   | 7 Left/right trackpad buttons |
| 4 Power/sleep button | 8 Speakers                    |

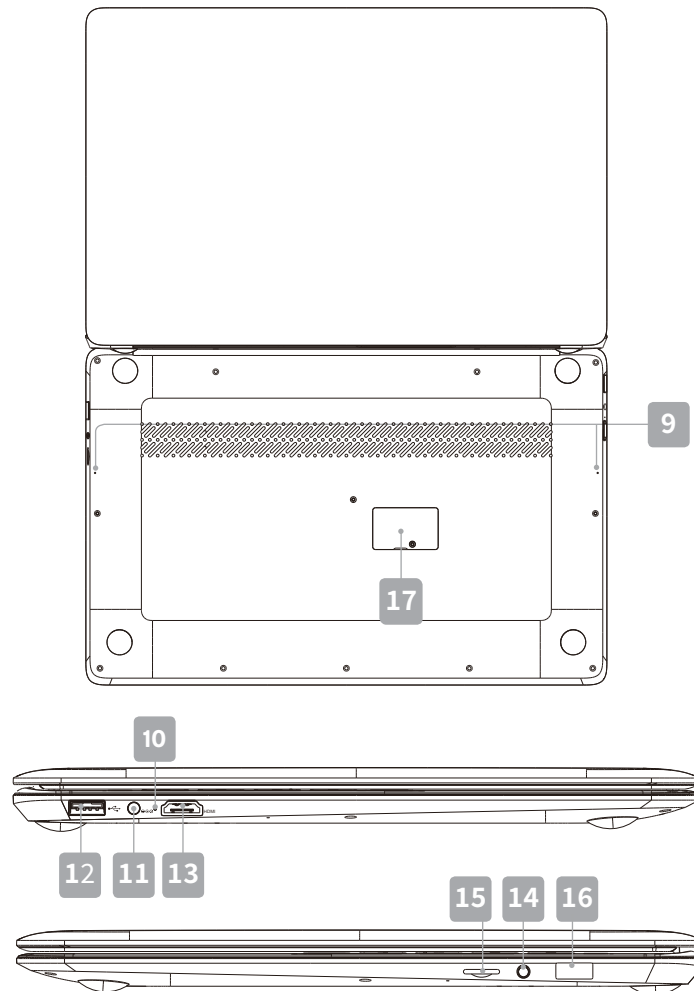

- |                            |                              |
|----------------------------|------------------------------|
| <b>9</b> Microphones       | <b>14</b> 3.5mm audio output |
| <b>10</b> Charge indicator | <b>15</b> Micro SD card port |
| <b>11</b> Power input      | <b>16</b> USB 3.0 port       |
| <b>12</b> USB 3.0 port     | <b>17</b> M.2 SSD            |
| <b>13</b> HDMI output      |                              |

# Getting Started

## 1. Connecting power supply

- a. Plug the power adapter into a suitable power outlet.
  - b. Insert adapter into the laptop's power input port.
- The indicator light will illuminate if power is being received.

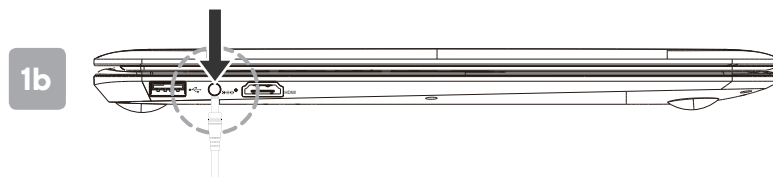

When connected, the laptop will automatically begin to charge. Ensure the battery has been charged for at least 3 hours before using without a power supply for the first time.

## 2. Power on the laptop

- a. Lift to open the display panel.
- b. Press the power button.
- c. Set up laptop and create account according to prompts for initial use.

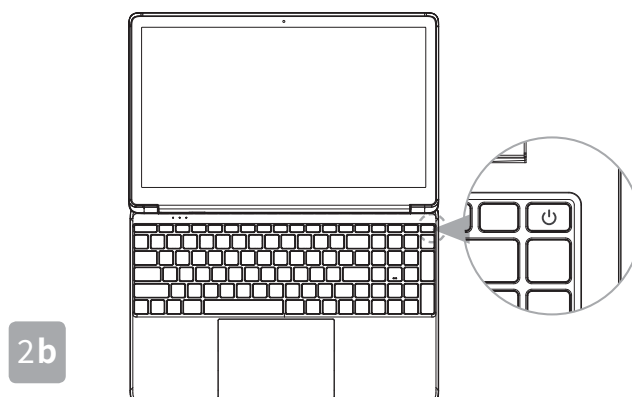
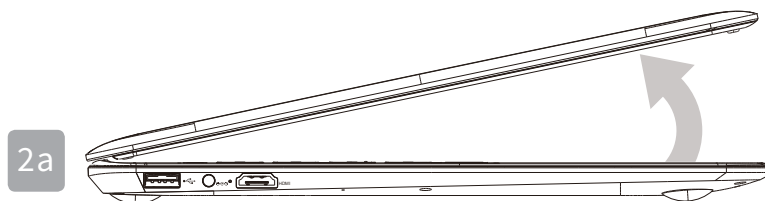

### 3. Start menu (3a)

Clicking in the lower-left corner of the homescreen will open Windows 10's Start menu. This menu contains applications, shortcuts to the documents and pictures folders, as well as a shortcut to the laptop's settings menu.



### Pinned apps (3b)

Some of the applications are "pinned" to the start menu, appearing in the large grid on the right-hand side of the start menu. This list can be customised at any time.



### Action centre (3c)

In the lower-right corner of the homescreen, the action centre can be expanded. This includes many adjustable settings and any notifications and messages from apps.

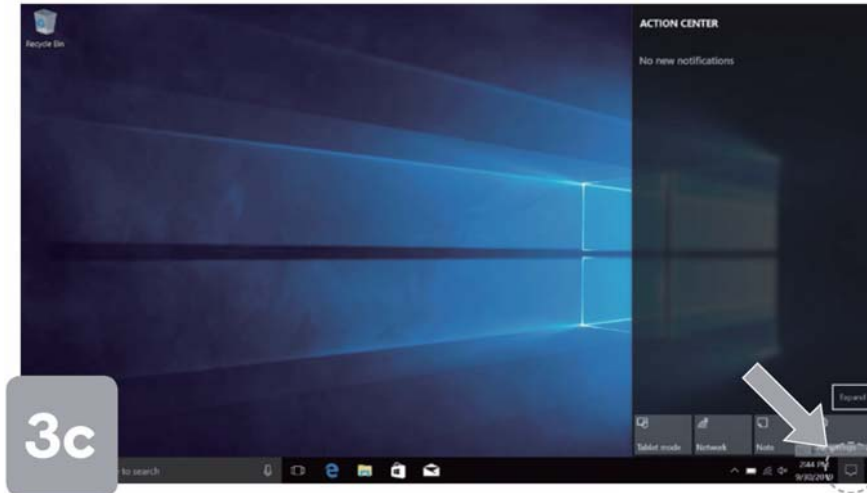

### Power options, shutting down (3d)

In the Start menu, you will find the power options. Here you will be able to select either sleep, shut down or restart. To turn on laptop safely, select shut down from this list.

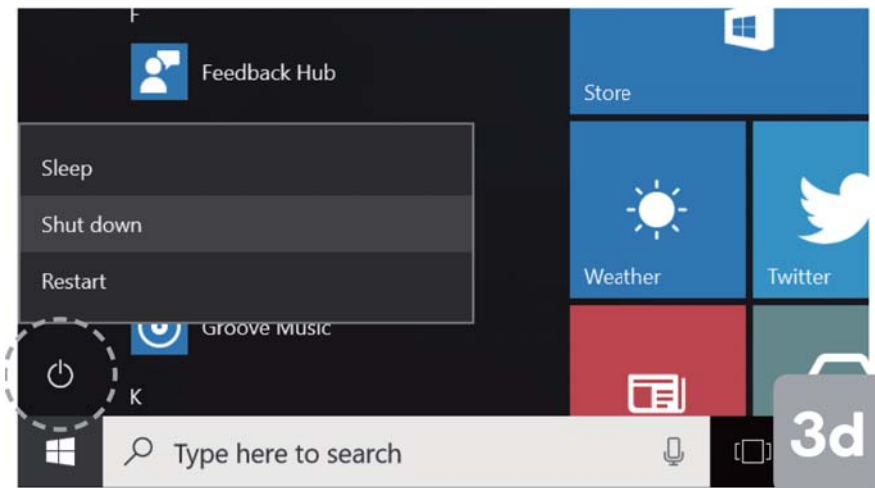



## Notes:

- The power button can also be used to enter and exit sleep mode.  
If the laptop is unresponsive, holding down the power button for an extended period will shut down the device.
- Hold the 'Fn' key on the keyboard while pressing the function buttons (for example, Fn + F7 to increase display brightness).
- Do not use the laptop with any power supply or adaptor other than the one provided.

### Connecting an Android phone to Windows 10

- When you plug in your phone to your PC via USB, you'll see a notification up top with an option to select USB transfer options on your phone.
- Please check that you have selected either "Transfer files(MTP)" or "Transfer photos(PTP)" from the USB transfer options.

## Troubleshooting

Issue	Possible solution
Laptop is not turning on/ charging	<ul style="list-style-type: none"> <li>● Leave the unit on charge for at least an hour before attempting to turn the unit on.</li> <li>● The battery may have naturally depleted and may take some time to recharge. If in storage for extended periods, it is recommended to periodically charge the unit to keep the battery capacity high, as batteries naturally deteriorate and eventually completely die over time.</li> <li>● Make note if any lights turn on or if any internal components like fan turn on.</li> <li>● Inspect the unit, charging port and power cord for any physical damage or debris. If you notice any damage to the power cord, please do not use it and contact us.</li> </ul>
Wi-Fi connection is not working	<ul style="list-style-type: none"> <li>● Restart your modem/router both if you have separate units.</li> <li>● Reconnect any range extenders that may be in use.</li> <li>● Restart the device that is having issues.</li> <li>● Try moving the device closer to the source.</li> <li>● If you cannot connect at all, double-check that all passwords are correct.</li> <li>● If you can connect but are getting weak or slow data, try disconnecting the device from the network manually and reconnect.</li> </ul>
Screen darkens when unplugged	<ul style="list-style-type: none"> <li>● This will be occurring due to your power plan settings. You can adjust your power plan settings through the control panel.</li> </ul>
Forgotten Windows password	<p>There are several options to reset a Microsoft password:</p> <ul style="list-style-type: none"> <li>● Use a password reset disc via USB.</li> <li>● Reset Microsoft account password online with another device.</li> <li>● Reset Windows back to the factory default. Please note, this will delete all personal files and settings.</li> </ul>

# Notes

This device complies with part 15 of the FCC Rules. Operation is subject to the following two conditions:

(1) This device may not cause harmful interference, and (2) this device must accept any interference received, including interference that may cause undesired operation.

Any changes or modifications not expressly approved by the party responsible for compliance could void the user's authority to operate the equipment.

This equipment has been tested and found to comply with the limits for a Class B digital device, pursuant to part 15 of the FCC Rules.

These limits are designed to provide reasonable protection against harmful interference in a residential installation. This equipment generates, uses and can radiate radio frequency energy and, if not installed and used in accordance with the instructions, may cause harmful interference to radio communications. However, there is no guarantee that interference will not occur in a particular installation. If this equipment does cause harmful interference to radio or television reception, which can be determined by turning the equipment off and on, the user is encouraged to try to correct the interference by one or more of the following measures:

—Reorient or relocate the receiving antenna.

—Increase the separation between the equipment and receiver.

—Connect the equipment into an outlet on a circuit different from that to which the receiver is connected.

—Consult the dealer or an experienced radio/TV technician for help.

FCC Radiation Exposure Statement:

This equipment complies with FCC radiation exposure limits set forth for an uncontrolled environment .

This transmitter must not be co-located or operating in conjunction with any other antenna or transmitter.

**Need more information?**

We hope that this user guide has given you  
the assistance needed for a simple set-up.  
For the most up-to-date guide for your product,  
as well as any additional assistance you may require,  
head online to contact us.  
[www.azeyou.com](http://www.azeyou.com)

