

Thank you for choosing the RENPHO Eyeris Shift! This device combines an eye massager unit and a light eye mask for an innovative solution that merges the benefits of eye massage with the convenience of a heated eye mask. We wish you a soothing and revitalizing experience with the RENPHO Eyeris Shift.

### IMPORTANT SAFETY INSTRUCTIONS

#### READ ALL INSTRUCTIONS CAREFULLY BEFORE USE.

- This device is intended for personal care use only and not for medical or commercial purposes.
- This device is not intended for use by children or persons living with a disability (reduced physical, sensory, or cognitive condition), or individuals lacking the necessary experience and knowledge to safely operate it unless they are properly supervised or instructed by a responsible person.
- Children should not play with the device.
- Cleaning and maintenance should not be conducted by children.

#### DANGER - To reduce the risk of electric shock:

- Never use pins or other metallic fasteners with this device.
- Do not use the device with wet hands or submerge the device in water, or any liquid.

#### WARNING - To reduce the risk of burns, fire, or injury to persons:

- Please consult a doctor before use if you fit into any of the following user groups:
  - Persons who have undergone eye surgery or eye conditions such as glaucoma, cataract, and retinal detachment
  - The elderly
  - Pregnant or postpartum women
  - Persons allergic to suede or milk fiber
  - Persons with skin infections, sensitivity, redness, and/or burns on the skin
  - Persons with any swelling or wound around the eye area
  - Persons using a pacemaker or other implantable medical devices
  - Persons with a heart condition, malignant tumors, or other serious health conditions

- Persons undergoing medical treatment
  - Persons with high or abnormal blood pressure
- Remove contact lenses, glasses, false eyelashes, hairpins, and any other accessories before use.
  - If you experience any discomfort during use, stop using the device immediately.
  - Do not use the device under blankets, pillows, or any other object that can cause excessive heating.
  - Do not use the device if it is not working properly, has been damaged, or dropped into water.
  - Do not use the device while driving, walking, or running.
  - Only use the charger (DC 5V 2A, not included) to recharge the device.
  - Avoid contact with sharp objects.
  - Be careful when using heated surfaces, as they may cause serious burns. Do not use over insensitive skin areas or on persons with poor circulation. Children or incapacitated persons should not use heat unattended.
  - High temperatures may cause burns to occur regardless of the control setting. Do not use the device on infants or persons who are with disabilities or unconscious. Check frequently where the skin is in contact with the heated area to reduce the risk of blistering.
  - This device contains a non-replaceable battery. When the battery reaches its end, the device should be properly disposed of.
  - Do not expose the device or battery to excessive temperatures.

#### SAVE THESE INSTRUCTIONS

### WHAT'S IN THE BOX

- Eyeris Shift x1
- Charging Cable x1
- Storage Bag x1
- User Manual x1
- Quick Guide Card x1

### ABOUT YOUR EYERIS SHIFT

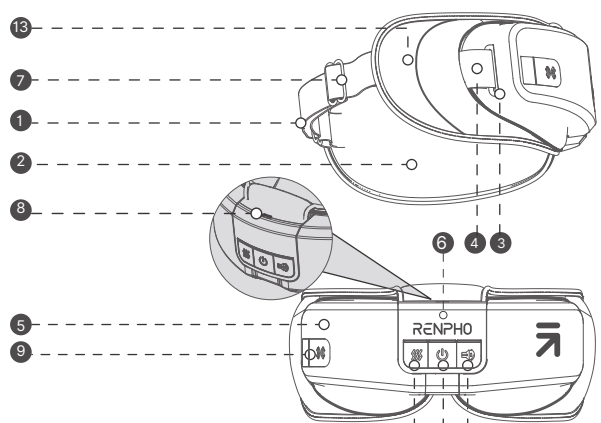

- Elastic Headband
- Removable Mask (Standalone)
- Hook Buckles
- Straps
- Pressure Module (Not Standalone)
- Main Control Unit
- Adjustable Buckle
- Charging Port
- Pressure Button (Indicator)
- Heat / Silent Mode Button (Indicator)
- Power / Timer Button (Indicator)
- Volume / Next Track / Bluetooth Button (Indicator)
- Adjustable Speakers

### Indicator

Status	Indicator
Device is turned on or working.	Power indicator turns solid white.
Device is in low battery or charging.	Power indicator flashes red slowly.
Device is fully charged.	Power indicator turns solid red.
Device is charging at a voltage higher than 6V.	Power indicator keeps flashing red quickly for 1min and then turns off, indicating a wrong charger is used.
Bluetooth is disconnected.	Bluetooth indicator turns solid white.
Bluetooth is connected.	Bluetooth indicator turns solid blue.
"Low heat" is selected.	Heat indicator turns solid white.
"Medium heat" is selected.	Heat indicator turns solid blue.
"High heat" is selected.	Heat indicator turns solid red.
"No temperature" is selected.	Heat indicator turns off.
"Soft pressure" is selected.	Pressure indicator turns solid white.
"Strong pressure" is selected.	Pressure indicator turns solid red.
"No pressure" is selected.	Pressure indicator turns off.
Turn off the device when "no pressure" is selected and then turn on.	Pressure indicator keeps flashing white for 5 seconds and then turns off, indicating the pressure module is installed properly.

### CHARGING YOUR EYERIS SHIFT

Fully charge the device before initial use.

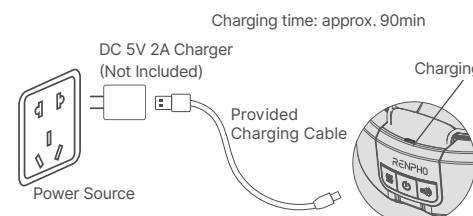

Note: Do not use the device while charging.

### DETACHING/ATTACHING THE EYE MASK

#### 1. Separate the Eye Mask from Pressure Module:

- Use your thumb to firmly push the main control unit upward to uninstall it.
- Carefully unfasten the straps from the plastic hooks.
- Gently remove the mask from the pressure module.
- Attach the main control unit in place using the fastening fabric.

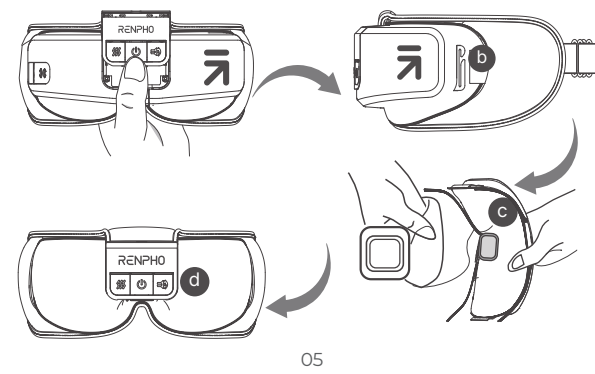

### 2. Attach the Mask for Eye Massage Use:

- Carefully detach the main control unit from the eye mask and connect the main control unit to the pressure module, ensuring there is no gap between them.
- Align the nose contour of the eye mask with that of the pressure module and attach the mask to the pressure module using the fastening fabric.
- Securely fasten the straps on both sides of the device.

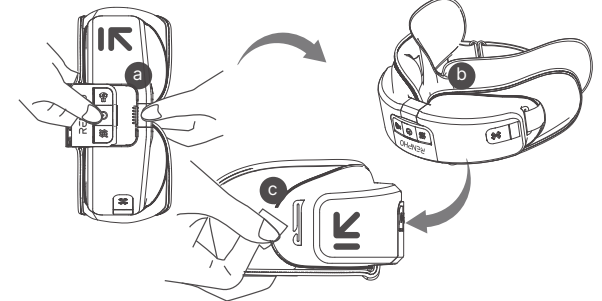

### WEARING YOUR EYERIS SHIFT

- Before wearing, remove any eye accessories (e.g. eyeglasses, false eyelashes, etc.). Wear the device and adjust the headband to ensure a comfortable fit and effective light blocking.
- Adjust the speakers to keep them near your tragus for optimal auditory experience.

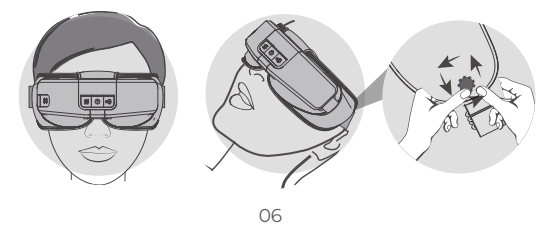

### FCC Regulatory Compliance

This device complies with part 15 of the FCC Rules. Operation is subject to the following two conditions:  
 (1) This device may not cause harmful interference, and (2) this device must accept any interference received, including interference that may cause undesired operation.  
 Warning: Changes or modifications not expressly approved by the party responsible for compliance could void the user's authority to operate the equipment.  
 Note: This equipment has been tested and found to comply with the limits for a Class B digital device, pursuant to Part 15 of the FCC Rules. These limits are designed to provide reasonable protection against harmful interference in a residential installation. This equipment generates, uses and can radiate radio frequency energy and, if not installed and used in accordance with the instructions, may cause harmful interference to radio communications.  
 However, there is no guarantee that interference will not occur in a particular installation. If this equipment does cause harmful interference to radio or television reception, which can be determined by turning the equipment off and on, the user is encouraged to try to correct the interference by one or more of the following measures:  
 - Reorient or relocate the receiving antenna.  
 - Increase the separation between the equipment and receiver.  
 - Connect the equipment into an outlet on a circuit different from that to which the receiver is connected.  
 - Consult the dealer or an experienced radio/TV technician for help.

### RF Exposure Compliance

This equipment complies with FCC radiation exposure limits set forth for an uncontrolled environment. This transmitter must not be co-located or operating in conjunction with any other antenna or transmitter.

### ISED Regulatory Compliance

This device contains licence-exempt transmitters that comply with Innovation, Science and Economic Development Canada's licence-exempt RSSI(s).  
 Operation is subject to the following two conditions:  
 (1) This device may not cause interference.  
 (2) This device must accept any interference, including interference that may cause undesired operation of the device.

Le présent appareil est conforme aux CNR d'Industrie Canada applicables aux appareils radio exempts de licence. L'exploitation est autorisée aux deux conditions suivantes:  
 (1) l'appareil ne doit pas produire de brouillage, et (2) l'utilisateur de l'appareil doit accepter tout brouillage radioélectrique subi, même si le brouillage est susceptible d'en compromettre le fonctionnement.  
 This equipment complies with IC RSSI-102 radiation exposure limits set forth for an uncontrolled environment.  
 Cet équipement est conforme aux limites d'exposition aux radiations IC CNR-102 établies pour un environnement non contrôlé.

### US Importer: JOICOM CORPORATION

14129 The Merge Street, Building 3 Unit A, Eastvale, CA 92880

### Manufacturer: Shenzhen Ruiyi Business Technology Co., Ltd.

No. 810-C063, 8th Floor, Xiangbin International Financial Centre, No.18, West Free Trade Street, China Special Economic Zone, Qianhai Bay, Shenzhen, Guangdong Province, 518000 China

Made in China

NA1

成品尺寸	90*130mm
材质	铜版纸128g
工艺	无
颜色	黑白印刷
装订方式: 风琴页	

### USING YOUR EYERIS SHIFT

Button	Function	Eye Massager	Mask
	a. Press and hold to power on/off. b. Press to select the timer: 10min (default)/20min/30min. c. Double press to enable/disable the "no timer" function. When "no timer" is activated, only music and Bluetooth functions are available.	✓	✓
	a. Press to adjust the temperature: high heat (118°F, default)/no temperature /low heat (107°F)/medium heat (113°F). b. Press and hold to switch between voice mode and silent mode. In silent mode, the voice broadcast and included music will be disabled. The music playing from your smartphone will be paused but can be resumed through your smartphone.	✓	✓
	a. Press to cycle the music volume through level 3 (default),4,5,0/1/2. b. Press and hold to switch to the next music track. c. Double press to turn on/off Bluetooth. When the device is turned on, Bluetooth is enabled by default.	✓	✓

Button	Function	Eye Massager	Mask
	a. Press to adjust the air pressure level: soft pressure (default)/strong pressure/no pressure. Once "no pressure" is selected, the Pressure Mode Button will not respond. b. Press and hold to cycle through the following pressure modes: Tension Relief Mode: eyes & temples (default) Retinal Protection Mode: eyes only Regeneration Mode: temples only	✓	
<b>Note:</b> <ul style="list-style-type: none"> <li>Memory function: The device automatically recalls the last set heat level, pressure level, pressure mode and auto-off timer once turned on again.</li> <li>Auto-off timer: Once the timer is set, the device will operate for the selected duration and then automatically shut off.</li> </ul>			

### CONNECTING TO BLUETOOTH

- Turn on the device and enable Bluetooth on your smartphone.
  - Search for **"R-G011"** via your Bluetooth settings and connect to play your music playlist through the device.
- Note:** Once paired successfully, the device will be automatically connected to Bluetooth next time, followed by a voice prompt "Bluetooth connected".

### CARE & MAINTENANCE

- Turn off the device and allow it to cool down before cleaning or storing.
- Wipe the device surface with a soft cotton cloth slightly dampened with mild detergent. Do not submerge it in water or use bleach or corrosive cleaners.
- Ensure the device is clean and dry before storing. Store it in a cool, dry place, away from direct sunlight, moisture, heat, and corrosive gases.
- If the device has not been used for over 3 months, charge it periodically to prolong its lifespan.
- Do not disassemble or repair the device by yourself, as this may cause damage and void the manufacturer's warranty.

### TROUBLESHOOTING GUIDE

Problem	Possible Cause	Solution
Pressure function does not work.	The main control unit is not installed properly.	Ensure the main control unit is installed properly and securely.
	"No pressure" is selected.	Switch to "low pressure" or "high pressure".
	"No timer" is selected.	Deactivate the "no timer" function.
There is weak air pressure.	The mask and the pressure module may not be aligned or installed properly, or the straps are not fastened securely.	When installing, align the nose contour of the mask with that of the pressure module and then secure the straps.
	"Soft pressure" is selected.	Switch to "strong pressure".
	The device is worn too loosely.	Adjust the headband for a snug fit.

Problem	Possible Cause	Solution
Charging is not happening or slow.	Use a charger with a voltage higher than 6V.	Use a DC 5V 2A charger (not included).
	Use other types of charging cables.	Use the provided charging cable or DC 5V 2A charging cable only.
Fail to connect to Bluetooth.	Bluetooth on smartphone is not enabled.	Enable Bluetooth on smartphone and connect to "R-G011".
	The device is connected to another mobile device.	Ensure the device is fully disconnected from another mobile device.
	The device is off.	Turn on the device and connect to Bluetooth.
There is no voice broadcast, no music, or the sound of music is faint.	Silent mode is selected.	Switch to voice mode.
	Bluetooth music is playing at volume level 0.	Adjust the volume level through your smartphone.
	Music volume level 0 or low music volume level is selected through the device.	Adjust the music volume level.
There is no heat.	"No temperature" or "low heat" is selected.	Adjust the heat level.
	The device needs time to warm up.	Wait for 1min after power on.
	Built-in overheat protection.	It is normal. The device will automatically restart after cooling down.

Problem	Possible Cause	Solution
Fail to turn on the device.	Out of power.	Charge the device.
	Short press the Power Button.	Long press the Power Button to turn on the device.
The device stops working suddenly.	Out of power.	Charge the device.
	The built-in auto-off timer is activated.	Restart the device if needed.
<b>If you encounter any other problems, please contact our customer service.</b>		

### TECHNICAL SPECIFICATIONS

Product Name: Eye Massager  
 Model: R-G011  
 Input: 5V = 2A  
 Battery Capacity: 1500mAh

### WARRANTY POLICY

Your RENPHO product purchase is covered by a one-year limited manufacturer warranty from the date of delivery.

For warranty terms and conditions, please visit :  
<https://renpho.com/pages/warranty-terms-and-conditions>

Note: Product registration is not required for the warranty. If you choose not to register your product, it will not diminish the product warranty.

### CUSTOMER SERVICE

Please feel free to contact us if you have any questions or concerns. RENPHO Customer Service Team guarantees a quick response and hassle-free solutions to any issue you may have within business hours.

**1(844) 417-0149 (US ONLY)**  
 Monday-Friday 9:00AM-4:30PM  
**1800 MY RENPHO (1800 69 7367) (AU ONLY)**  
 Monday-Friday 9:00AM-6:00PM (AEST)  
**support@renpho.com (US&CA)**  
**support-au@renpho.com (AU)**

\*For defective products or the return of items, please contact us with your order number within the specified warranty period. DO NOT dispose of any product parts as they may be required for inspection/repair.

**RENPHO**  
 Smart Health Simplified

User Manual

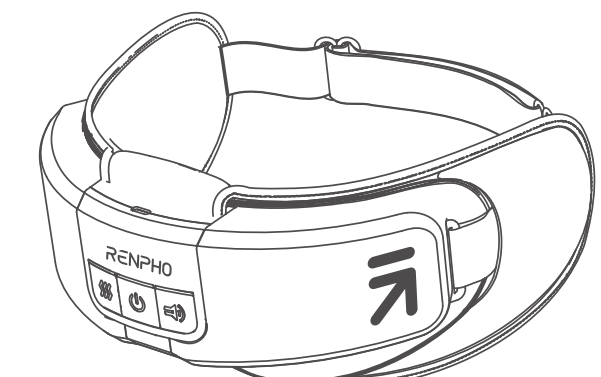

Model: R-G011  
**Eyeris Shift**

01

02

03

04

05

06

07

08

09

10

11

12