



FCC SAR TEST REPORT

Report No.: STS2206143H01

Issued for

Tag-N-Trac Inc.

4250 Executive Sq, #675, La Jolla, California, United States,
92037

Product Name:	Smart Sense Tag
Brand Name:	TAG-N-TRAC
Model Name:	ST100
Series Model:	N/A
FCC ID:	2A24I-V06G12J16
Test Standard:	ANSI/IEEE Std. C95.1
	FCC 47 CFR Part 2 (2.1093)
	IEEE 1528: 2013
Max. Report SAR (1g):	Body: 0.668 W/kg

Any reproduction of this document must be done in full. No single part of this document may be reproduced without permission from STS, All Test Data Presented in this report is only applicable to presented Test sample.

ShenZhen STS Test Services Co.,Ltd.

A 1/F, Building B, Zhuoke Science Park, No.190 Chongqing Road, HepingShequ, Fuyong Sub-District, Bao'an District, Shenzhen, Guang Dong, China

TEL: +86-755 3688 6288 FAX: +86-755 3688 6277 E-mail:sts@stsapp.com





Test Report Certification

Applicant's name : Tag-N-Trac Inc.
Address : 4250 Executive Sq, #675, La Jolla, California, United States, 92037
Manufacturer's Name : Chongqing Huiye IoT Technology Co.,Ltd.
Address : FL.5, Haibo Building 2, No.829, Yishan Rd, Xuhui, Shanghai. 200233

Product description

Product name : Smart Sense Tag
Brand name : TAG-N-TRAC
Model name : ST100
Series Model..... : N/A

Standards..... : ANSI/IEEE Std. C95.1-1992
 FCC 47 CFR Part 2 (2.1093)
 IEEE 1528: 2013

The device was tested by Shenzhen STS Test Services Co., Ltd. in accordance with the measurement methods and procedures specified in KDB 865664 The test results in this report apply only to the tested sample of the stated device/equipment. Other similar device/equipment will not necessarily produce the same results due to production tolerance and measurement uncertainties.

Date of Test..... :
Date (s) of performance of tests..... : 04 Aug. 2022
Date of Issue..... : 08 Aug. 2022
Test Result..... : **Pass**

Testing Engineer : Shi fan-long
 (Shifan. Long)

Technical Manager : Sean She
 (Sean she)

Authorized Signatory : Bovey Yang
 (Bovey Yang)





Table of Contents

1. General Information	5
1.1 EUT Description	5
1.2 Test Environment	6
1.3 Test Factory	6
2. Test Standards and Limits	7
3. SAR Measurement System	8
3.1 Definition of Specific Absorption Rate (SAR)	8
3.2 SAR System	8
4. Tissue Simulating Liquids	11
4.1 Simulating Liquids Parameter Check	11
5. SAR System Validation	13
5.1 Validation System	13
5.2 Validation Result	13
6. SAR Evaluation Procedures	14
7. EUT Test Position	15
7.1 Body-worn Position Conditions	15
8. Uncertainty	16
8.1 Measurement Uncertainty	16
9. Conducted Power Measurement	17
9.1 Test Result	17
10. EUT and Test Setup Photo	22
10.1 EUT Photo	22
10.2 Setup Photo	25
11. SAR Result Summary	26
11.1 Body-worn SAR	26
12. Equipment List	27
Appendix A. System Validation Plots	28
Appendix B. SAR Test Plots	36
Appendix C. Probe Calibration and Dipole Calibration Report	41



Revision History

Rev.	Issue Date	Report No.	Effect Page	Contents
00	08 Aug. 2022	STS2206143H01	ALL	Initial Issue





1. General Information

Environmental evaluation measurements of specific absorption rate (SAR) distributions in emulated human head and body tissues exposed to radio frequency (RF) radiation from wireless portable devices for compliance with the rules and regulations of the U.S. Federal Communications Commission (FCC).

1.1 EUT Description

Product Name	Smart Sense Tag		
Brand Name	TAG-N-TRAC		
Model Name	ST100		
Series Model	N/A		
Model Difference	N/A		
Battery	Rated Voltage: 3.7V Charge Limit Voltage: 4.2V Capacity: 280mAh		
Device Category	Portable		
Product stage	Production unit		
RF Exposure Environment	General Population / Uncontrolled		
Hardware Version	QHY003_V1.03		
Software Version	MCU_02_02_00_00_11751_APP_01_00_LO		
Frequency Range	CAT-M Band 2:1850~1910MHz CAT-M Band 4:1710~1755MHz CAT-M Band 12:699~716MHz CAT-M Band 13:777~787MHz CAT-M Band 25:1850~1915MHz		
Max. Reported SAR(1g): (Limit:1.6W/kg)	Band	Mode	Body Worn (W/kg)
	PCB	CAT-M FDD Band 2	0.582
	PCB	CAT-M FDD Band 4	0.668
	PCB	CAT-M FDD Band 12	0.348
	PCB	CAT-M FDD Band 13	0.387
PCB	CAT-M FDD Band 25	0.553	
FCC Equipment Class	PCS Licensed Transmitter (PCB)		
Operating Mode:	CAT-M Band: QPSK, 16QAM		
Antenna Specification:	CAT-M Band: Monopole Antenna		
SIM Card	Built-in card.		
DTM Mode	Not Support		
Note:	1. The EUT battery must be fully charged and checked periodically during the test to ascertain uniform power		



1.2 Test Environment

Ambient conditions in the SAR laboratory:

Items	Required
Temperature (°C)	18-25
Humidity (%RH)	30-70

1.3 Test Factory

ShenZhen STS Test Services Co.,Ltd.

A 1/F, Building B, Zhuoke Science Park, No.190 Chongqing Road, HepingShequ, Fuyong Sub-District, Bao'an District, Shenzhen, Guang Dong, China

FCC test Firm Registration No.: 625569

IC Registration No.: 12108A

A2LA Certificate No.: 4338.01





2. Test Standards and Limits

No.	Identity	Document Title
1	47 CFR Part 2	Frequency Allocations and Radio Treaty Matters; General Rules and Regulations
2	ANSI/IEEE Std. C95.1-1992	IEEE Standard for Safety Levels with Respect to Human Exposure to Radio Frequency Electromagnetic Fields, 3 kHz to 300 GHz
3	IEEE Std. 1528-2013	Recommended Practice for Determining the Peak Spatial-Average Specific Absorption Rate (SAR) in the Human Head from Wireless Communications Devices: Measurement Techniques
4	FCC KDB 447498 D04 v01	RF Exposure Procedures and Equipment Authorization Policies for Mobile and Portable Devices
5	FCC KDB 865664 D01 v01r04	SAR Measurement 100 MHz to 6 GHz
6	FCC KDB 865664 D02 v01r02	RF Exposure Reporting
7	FCC KDB 941225 D05 v02r05	SAR for LTE Devices
8	FCC KDB 648474 D04 v01r03	SAR Evaluation Considerations for Wireless Handsets

(A). Limits for Occupational/Controlled Exposure (W/kg)

Whole-Body	Partial-Body	Hands, Wrists, Feet and Ankles
0.4	8.0	20.0

(B). Limits for General Population/Uncontrolled Exposure (W/kg)

Whole-Body	Partial-Body	Hands, Wrists, Feet and Ankles
0.08	1.6	4.0

NOTE: Whole-Body SAR is averaged over the entire body, partial-body SAR is averaged over any 1 gram of tissue defined as a tissue volume in the shape of a cube. SAR for hands, wrists, feet and ankles is averaged over any 10 grams of tissue defined as a tissue volume in the shape of a cube.

Population/Uncontrolled Environments:

Are defined as locations where there is the exposure of individuals who have no knowledge or control of their exposure.

Occupational/Controlled Environments:

Are defined as locations where there is exposure that may be incurred by people who are aware of the potential for exposure, (i.e. as a result of employment or occupation).

NOTE

GENERAL POPULATION/UNCONTROLLED EXPOSURE

PARTIAL BODY LIMIT

1.6 W/kg

3. SAR Measurement System

3.1 Definition of Specific Absorption Rate (SAR)

SAR is related to the rate at which energy is absorbed per unit mass in an object exposed to a radio field. The SAR distribution in a biological body is complicated and is usually carried out by experimental techniques or numerical modeling. The standard recommends limits for two tiers of groups, occupational/controlled and general population/uncontrolled, based on a person's awareness and ability to exercise control over his or her exposure. In general, occupational/controlled exposure limits are higher than the limits for general population/uncontrolled.

The SAR definition is the time derivative (rate) of the incremental energy (dW) absorbed by (dissipated in) an incremental mass (dm) contained in a volume element (dv) of a given density (ρ). The equation description is as below:

$$SAR = \frac{d}{dt} \left(\frac{dW}{dm} \right) = \frac{d}{dt} \left(\frac{dW}{\rho dv} \right)$$

SAR is expressed in units of Watts per kilogram (W/kg) SAR measurement can be related to the electrical field in the tissue by

$$SAR = \frac{\sigma E^2}{\rho}$$

Where: σ is the conductivity of the tissue,
ρ is the mass density of the tissue and E is the RMS electrical field strength.

3.2 SAR System

MVG SAR System Diagram:

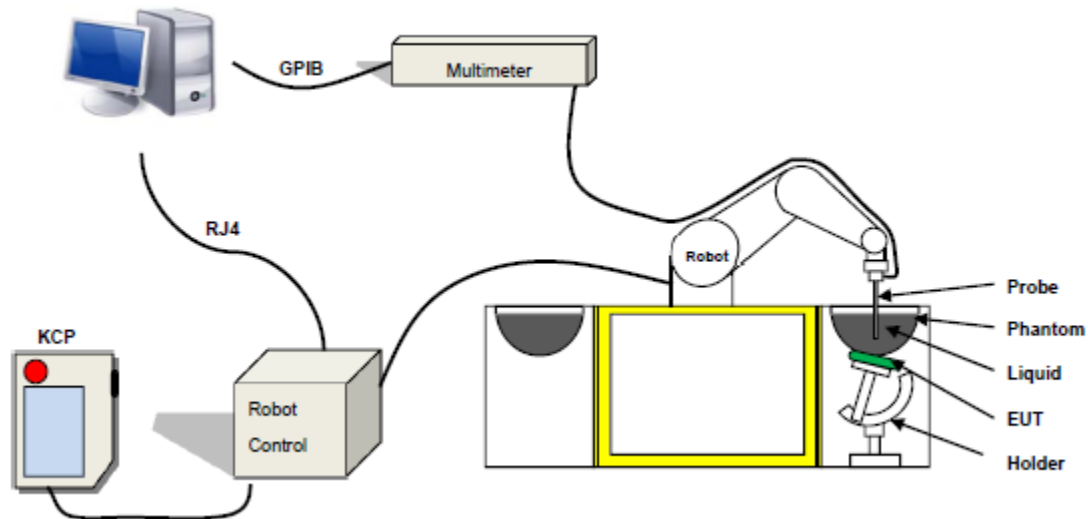

COMOSAR is a system that is able to determine the SAR distribution inside a phantom of human being according to different standards. The COMOSAR system consists of the following items:

- Main computer to control all the system
- 6 axis robot
- Data acquisition system
- Miniature E-field probe
- Phone holder
- Head simulating tissue

The following figure shows the system.



The EUT under test operating at the maximum power level is placed in the phone holder, under the phantom, which is filled with head simulating liquid. The E-Field probe measures the electric field inside the phantom. The Open SAR software computes the results to give a SAR value in a 1g or 10g mass.

3.2.1 Probe

For the measurements the Specific Dosimetric E-Field Probe SN 07/21 EPGO352 with following specifications is used

- Probe Length: 330 mm
- Length of Individual Dipoles: 2 mm
- Maximum external diameter: 8 mm
- Probe Tip External Diameter: 2.5 mm
- Distance between dipole/probe extremity: 1 mm
- Dynamic range: 0.01-100 W/kg
- Probe linearity: 3%
- Axial Isotropy: < 0.10 dB
- Spherical Isotropy: < 0.10 dB
- Calibration range: 150 MHz to 6 GHz for head & body simulating liquid.
- Angle between probe axis (evaluation axis) and surface normal line: less than 30°



Figure 1-MVG COMOSAR Dosimetric E field Dipole

3.2.2 Phantom

For the measurements the Specific Anthropomorphic Mannequin (SAM) defined by the IEEE SCC-34/SC2 group is used. The phantom is a polyurethane shell integrated in a wooden table. The thickness of the phantom amounts to 2mm +/- 0.2mm. It enables the dosimetric evaluation of left and right phone usage and includes an additional flat phantom part for the simplified performance check. The phantom set-up includes a cover, which prevents the evaporation of the liquid.

SN 32/14 SAM115



Figure-SN 21/21 ELLI48



3.2.3 Device Holder

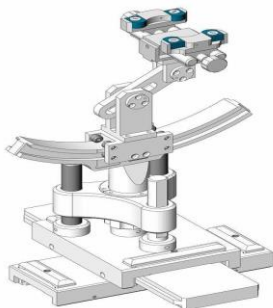

The SAR in the phantom is approximately inversely proportional to the square of the distance between the source and the liquid surface. For a source at 5 mm distance, a positioning uncertainty of ± 0.5 mm would produce a SAR uncertainty of ± 20 %. Accurate device positioning is therefore crucial for accurate and repeatable measurements. The positions in which the devices must be measured are defined by the standards.

4. Tissue Simulating Liquids



4. Tissue Simulating Liquids

4.1 Simulating Liquids Parameter Check

The head tissue dielectric parameters recommended by the IEEE SCC-34/SC-2 in P1528 have been incorporated in the following table. These head parameters are derived from planar layer models simulating the highest expected SAR for the dielectric properties and tissue thickness variations in a human head. Other head and body tissue parameters that have not been specified in P1528 are derived from the tissue dielectric parameters computed from the 4-Cole-Cole equations described in Reference [12] and extrapolated according to the head parameters specified in P1528.

Head Tissue

Frequency (MHz)	cellulose	DGBE	HEC	NaCl	Preventol	Sugar	X100	Water	Conductivity	Permittivity
	%	%	%	%	%	%	%	%	σ	ϵ_r
750	0.2	/	/	1.4	0.2	57.0	/	41.1	0.89	41.9
835	0.2	/	/	1.4	0.2	57.9	/	40.3	0.90	41.5
900	0.2	/	/	1.4	0.2	57.9	/	40.3	0.97	41.5
1800	/	44.5	/	0.3	/	/	30.45	55.2	1.4	40.0
1900	/	44.5	/	0.3	/	/	30.45	55.2	1.4	40.0
2000	/	44.5	/	0.3	/	/	/	55.2	1.4	40.0
2450	/	44.9	/	0.1	/	/	/	55.0	1.80	39.2
2600	/	45.0	/	0.1	/	/	/	54.9	1.96	39.0

Body Tissue

Frequency (MHz)	cellulose	DGBE	HEC	NaCl	Preventol	Sugar	X100	Water	Conductivity	Permittivity
	%	%	%	%	%	%	%	%	σ	ϵ_r
750	0.2	/	/	0.9	0.1	47.2	/	51.7	0.96	55.5
835	0.2	/	/	0.9	0.1	48.2	/	50.8	0.97	55.2
900	0.2	/	/	0.9	0.1	48.2	/	50.8	1.05	55.0
1800	/	29.4	/	0.4	/	/	30.45	70.2	1.52	53.3
1900	/	29.4	/	0.4	/	/	30.45	70.2	1.52	53.3
2000	/	29.4	/	0.4	/	/	/	70.2	1.52	53.3
2450	/	31.3	/	0.1	/	/	/	68.6	1.95	52.7
2600	/	31.7	/	0.1	/	/	/	68.2	2.16	52.3

Tissue dielectric parameters for head and body phantoms				
Frequency	ϵ_r		σ	
	S/m		S/m	
	Head	Body	Head	Body
300	45.3	58.2	0.87	0.92
450	43.5	56.7	0.87	0.94
900	41.5	55.0	0.97	1.05
1450	40.5	54.0	1.20	1.30
1800	40.0	53.3	1.40	1.52
2450	39.2	52.7	1.80	1.95
3000	38.5	52.0	2.40	2.73
5800	35.3	48.2	5.27	6.00



LIQUID MEASUREMENT RESULTS

Date	Ambient		Simulating Liquid		Parameters	Target	Measured	Deviation %	Limited %
	Temp. [°C]	Humidity %	Frequency (MHz)	Temp. [°C]					
2022-08-04	21.5	48	704	21.2	Permittivity	42.15	42.62	1.12	±5
					Conductivity	0.89	0.88	-1.12	±5
2022-08-04	21.5	49	750	21.2	Permittivity	41.90	42.15	0.60	±5
					Conductivity	0.89	0.93	4.49	±5
2022-08-04	21.6	50	782	21.3	Permittivity	41.75	40.95	-1.92	±5
					Conductivity	0.89	0.88	-1.12	±5
2022-08-04	21.7	50	1720	21.4	Permittivity	40.11	40.16	0.12	±5
					Conductivity	1.35	1.38	2.22	±5
2022-08-04	21.8	52	1732.5	21.5	Permittivity	40.10	41.23	2.82	±5
					Conductivity	1.36	1.40	2.94	±5
2022-08-04	21.9	53	1745	21.6	Permittivity	40.08	40.18	0.25	±5
					Conductivity	1.37	1.35	-1.46	±5
2022-08-04	22.0	54	1800	21.7	Permittivity	40.00	40.64	1.60	±5
					Conductivity	1.40	1.42	1.43	±5
2022-08-04	22.3	55	1860	22.1	Permittivity	40.00	40.42	1.05	±5
					Conductivity	1.40	1.36	-2.86	±5
2022-08-04	22.5	56	1880	22.2	Permittivity	40.00	40.28	0.70	±5
					Conductivity	1.40	1.38	-1.43	±5
2022-08-04	22.6	56	1900	22.3	Permittivity	40.00	40.40	1.00	±5
					Conductivity	1.40	1.38	-1.43	±5

5. SAR System Validation

5.1 Validation System

Each MVG system is equipped with one or more system validation kits. These units, together with the predefined measurement procedures within the MVG software, enable the user to conduct the system performance check and system validation. System kit includes a dipole, and dipole device holder. The system check verifies that the system operates within its specifications. It's performed daily or before every SAR measurement. The system check uses normal SAR measurement in the flat section of the phantom with a matched dipole at a specified distance. The system validation setup is shown as below.

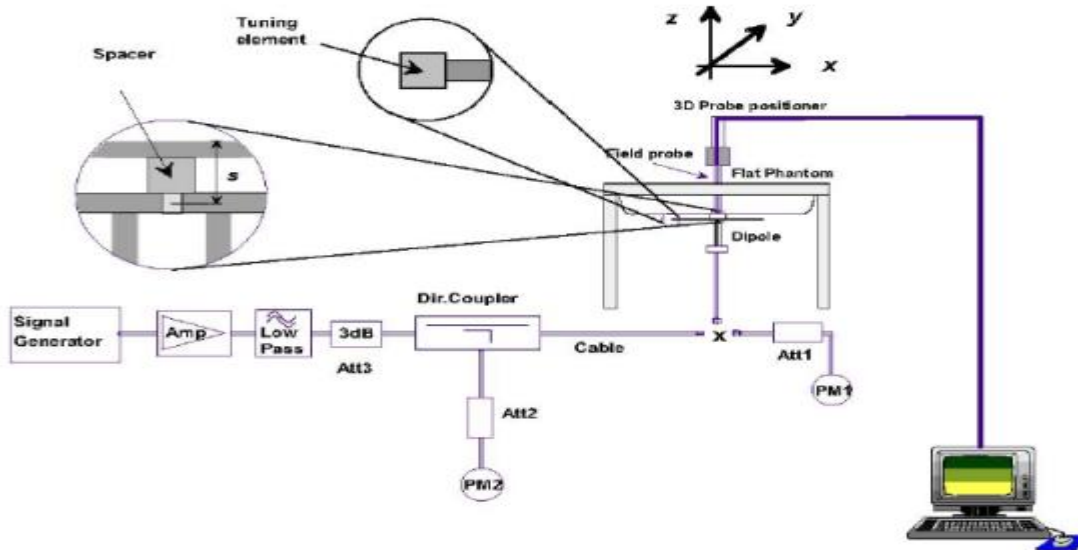

5.2 Validation Result

Comparing to the original SAR value provided by MVG, the validation data should be within its specification of 10 %.

Date	Freq.	Power	Tested Value	Normalized SAR	Target SAR	Tolerance	Limit
	(MHz)	(mW)	(W/Kg)	(W/kg)	1g(W/kg)	(%)	(%)
2022-08-04	750	100	0.861	8.61	8.49	1.41	10
2022-08-04	1800	100	3.859	38.59	38.31	0.73	10
2022-08-04	1900	100	3.986	39.86	39.72	0.35	10
2022-08-04	1900	100	3.992	39.92	39.84	0.20	10

Note:

1. The tolerance limit of System validation $\pm 10\%$.
2. The dipole input power (forward power) was 100 mW.
3. The results are normalized to 1 W input power.



6. SAR Evaluation Procedures

The procedure for assessing the average SAR value consists of the following steps:

The following steps are used for each test position

- Establish a call with the maximum output power with a base station simulator. The connection between the mobile and the base station simulator is established via air interface
- Measurement of the local E-field value at a fixed location. This value serves as a reference value for calculating a possible power drift.
- Measurement of the SAR distribution with a grid of 8 to 16mm * 8 to 16 mm and a constant distance to the inner surface of the phantom. Since the sensors cannot directly measure at the inner phantom surface, the values between the sensors and the inner phantom surface are extrapolated. With these values the area of the maximum SAR is calculated by an interpolation scheme.
- Around this point, a cube of 30 * 30 * 30 mm or 32 * 32 * 32 mm is assessed by measuring 5 or 8 * 5 or 8*4 or 5 mm. With these data, the peak spatial-average SAR value can be calculated.

➤ Area Scan & Zoom Scan

First Area Scan is used to locate the approximate location(s) of the local peak SAR value(s). The measurement grid within an Area Scan is defined by the grid extent, grid step size and grid offset. Next, in order to determine the EM field distribution in a three-dimensional spatial extension, Zoom Scan is required. The Zoom Scan is performed around the highest E-field value to determine the averaged SAR-distribution over 10 g. Area scan and zoom scan resolution setting follows KDB 865664 D01 quoted below. When the 1-g SAR of the highest peak is within 2 dB of the SAR limit, additional zoom scans are required for other peaks within 2 dB of the highest peak that have not been included in any zoom scan to ensure there is no increase in SAR.

7. EUT Test Position

This EUT was tested Front side and Back Side.

7.1 Body-worn Position Conditions

Body-worn Position Conditions:

Body-worn accessory exposure is typically related to voice mode operations when handsets are carried in body-worn accessories. The body-worn accessory procedures in KDB Publication 447498 D01 should be used to test for body-worn accessory SAR compliance, without a headset connected to it. When the same wireless transmission configuration is used for testing body-worn accessory and hotspot mode SAR, respectively, in voice and data mode, SAR results for the most conservative *test separation distance* configuration may be used to support both SAR conditions. When the *reported SAR* for a body-worn accessory, measured without a headset connected to the handset, is $> 1.2 \text{ W/kg}$, the highest *reported SAR* configuration for that wireless mode and frequency band should be repeated for the body-worn accessory with a headset attached to the handset.

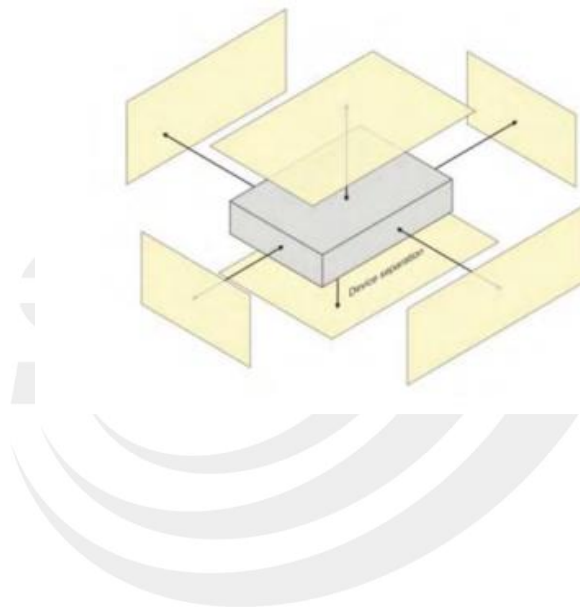



8. Uncertainty

8.1 Measurement Uncertainty

The following measurement uncertainty levels have been estimated for tests performed on the EUT as specified in IEEE 1528: 2013. This uncertainty represents an expanded uncertainty expressed at approximately the 95% confidence level using a coverage factor of k=2.

Uncertainty Component	Tol (+-%)	Prob. Dist.	Div.	Ci (1g)	Ci (10g)	1g Ui (+-%)	10g Ui (+-%)	vi
Measurement System								
Probe calibration	5.86	N	1	1	1	5.86	5.86	∞
Axial Isotropy	0.16	R	$\sqrt{3}$	$\sqrt{0.5}$	$\sqrt{0.5}$	0.07	0.07	∞
Hemispherical Isotropy	1.06	R	$\sqrt{3}$	$\sqrt{0.5}$	$\sqrt{0.5}$	0.43	0.43	∞
Boundary effect	1	R	$\sqrt{3}$	1	1	0.58	0.58	∞
Linearity	1.27	R	$\sqrt{3}$	1	1	0.73	0.73	∞
System detection limits	1.23	R	$\sqrt{3}$	1	1	0.71	0.71	∞
Modulation response	3.6	R	$\sqrt{3}$	1	1	3.60	3.60	∞
Readout Electronics	0.28	N	1	1	1	0.28	0.28	∞
Response Time	0.19	R	$\sqrt{3}$	1	1	0.11	0.11	∞
Integration Time	1.47	R	$\sqrt{3}$	1	1	0.85	0.85	∞
RF ambient conditions-Noise	3.5	R	$\sqrt{3}$	1	1	2.02	2.02	∞
RF ambient conditions-reflections	3.2	R	$\sqrt{3}$	1	1	1.85	1.85	∞
Probe positioner mechanical tolerance	1.4	R	$\sqrt{3}$	1	1	0.81	0.81	∞
Probe positioning with respect to phantom shell	1.4	R	$\sqrt{3}$	1	1	0.81	0.81	∞
Post-processing	2.3	R	$\sqrt{3}$	1	1	1.33	1.33	∞
Test sample Related								
Test sample positioning	3.1	N	1	1	1	3.10	3.10	∞
Device holder uncertainty	3.8	N	1	1	1	3.80	3.80	∞
SAR drift measurement	4.8	R	$\sqrt{3}$	1	1	2.77	2.77	∞
SAR scaling	2	R	$\sqrt{3}$	1	1	1.15	1.15	∞
Phantom and tissue parameters								
Phantom uncertainty (shape and thickness uncertainty)	4	R	$\sqrt{3}$	1	1	2.31	2.31	∞
Uncertainty in SAR correction for deviations in permittivity and conductivity	2	N	1	1	0.84	2.00	1.68	∞
Liquid conductivity (temperature uncertainty)	2.5	R	$\sqrt{3}$	0.78	0.71	1.95	1.78	∞
Liquid conductivity (measured)	4	N	1	0.78	0.71	0.92	1.04	M
Liquid permittivity (temperature uncertainty)	2.5	R	$\sqrt{3}$	0.23	0.26	1.95	1.78	∞
Liquid permittivity (measured)	5	N	1	0.23	0.26	1.15	1.30	M
Combined Standard Uncertainty		RSS				10.60	10.51	
Expanded Uncertainty (95% Confidence interval)		K=2				21.21	21.03	



9. Conducted Power Measurement

9.1 Test Result

CAT-M Conducted Power

CAT-M Band 2

LTE Band 2 Maximum Average Power [dBm]						
BW [MHz]	RB Size	RB Offset	Mod	Lowest	Middle	Highest
1.4	1	0	QPSK	22.37	22.41	22.35
1.4	6	0		22.22	22.30	22.16
1.4	1	0	16-QAM	22.20	22.21	22.00
1.4	5	0		22.02	22.07	21.81
3	1	0	QPSK	22.40	22.48	22.39
3	6	0		22.35	22.37	22.29
3	1	0	16-QAM	22.18	22.22	22.27
3	5	0		22.03	22.07	22.24
5	1	0	QPSK	22.52	22.63	22.58
5	6	0		22.43	22.48	22.44
5	1	0	16-QAM	22.41	22.46	22.29
5	5	0		22.29	22.26	22.20
10	1	0	QPSK	22.63	22.74	22.71
10	6	0		22.46	22.56	22.57
10	1	0	16-QAM	22.43	22.38	22.40
10	5	0		22.25	22.33	22.25
15	1	0	QPSK	22.70	22.82	22.71
15	6	0		22.66	22.67	22.57
15	1	0	16-QAM	22.65	22.59	22.54
15	5	0		22.63	22.39	22.50
20	1	0	QPSK	22.85	22.93	22.88
20	6	0		22.66	22.82	22.79
20	1	0	16-QAM	22.60	22.66	22.65
20	5	0		22.55	22.51	22.60



CAT-M Band 4

LTE Band 4 Maximum Average Power [dBm]						
BW [MHz]	RB Size	RB Offset	Mod	Lowest	Middle	Highest
1.4	1	0	QPSK	22.13	22.07	22.10
1.4	6	0		22.03	21.99	22.03
1.4	1	0	16-QAM	21.84	21.83	21.87
1.4	5	0		21.72	21.82	21.81
3	1	0	QPSK	22.22	22.14	22.17
3	6	0		22.18	21.94	22.08
3	1	0	16-QAM	22.14	21.78	22.04
3	5	0		22.13	21.72	22.02
5	1	0	QPSK	22.29	22.15	22.20
5	6	0		22.21	22.01	22.06
5	1	0	16-QAM	22.02	21.87	21.89
5	5	0		21.95	21.80	21.86
10	1	0	QPSK	22.37	22.28	22.25
10	6	0		22.30	22.17	22.18
10	1	0	16-QAM	22.13	22.09	21.99
10	5	0		22.04	22.03	21.87
15	1	0	QPSK	22.45	22.36	22.38
15	6	0		22.39	22.31	22.19
15	1	0	16-QAM	22.31	22.16	22.09
15	5	0		22.28	22.07	21.92
20	1	0	QPSK	22.57	22.46	22.43
20	6	0		22.52	22.30	22.30
20	1	0	16-QAM	22.47	22.26	22.21
20	5	0		22.37	22.10	22.13



CAT-M Band 12

LTE Band 12 Maximum Average Power [dBm]						
BW [MHz]	RB Size	RB Offset	Mod	Lowest	Middle	Highest
1.4	1	0	QPSK	22.24	22.31	22.37
1.4	6	0		22.23	22.25	22.26
1.4	1	0	16-QAM	22.17	22.15	22.11
1.4	5	0		21.98	22.05	22.03
3	1	0	QPSK	22.35	22.42	22.39
3	6	0		22.34	22.33	22.34
3	1	0	16-QAM	22.16	22.30	22.31
3	5	0		22.01	22.28	22.14
5	1	0	QPSK	22.54	22.47	22.43
5	6	0		22.43	22.29	22.28
5	1	0	16-QAM	22.42	22.15	22.16
5	5	0		22.23	21.98	22.15
10	1	0	QPSK	22.68	22.47	22.54
10	6	0		22.67	22.31	22.42
10	1	0	16-QAM	22.66	22.31	22.30
10	5	0		22.60	22.13	22.12

CAT-M Band 13

LTE Band 13 Maximum Average Power [dBm]						
BW [MHz]	RB Size	RB Offset	Mod	Lowest	Middle	Highest
5	1	0	QPSK	22.47	22.58	22.63
5	6	0		22.31	22.41	22.51
5	1	0	16-QAM	22.14	22.31	22.42
5	5	0		21.98	22.16	22.23
10	1	0	QPSK	/	22.69	/
10	6	0		/	22.53	/
10	1	0	16-QAM	/	22.52	/
10	5	0		/	22.52	/



CAT-M Band 25

LTE Band 25 Maximum Average Power [dBm]						
BW [MHz]	RB Size	RB Offset	Mod	Lowest	Middle	Highest
1.4	1	0	QPSK	22.36	22.43	22.39
1.4	6	0		22.33	22.28	22.24
1.4	1	0	16-QAM	22.18	22.08	22.05
1.4	5	0		22.02	21.90	21.96
3	1	0	QPSK	22.54	22.48	22.50
3	6	0		22.35	22.45	22.49
3	1	0	16-QAM	22.27	22.31	22.42
3	5	0		22.10	22.22	22.38
5	1	0	QPSK	22.58	22.55	22.49
5	6	0		22.52	22.45	22.40
5	1	0	16-QAM	22.46	22.27	22.28
5	5	0		22.42	22.19	22.21
10	1	0	QPSK	22.67	22.74	22.63
10	6	0		22.59	22.54	22.55
10	1	0	16-QAM	22.55	22.40	22.53
10	5	0		22.49	22.33	22.39
15	1	0	QPSK	22.78	22.84	22.80
15	6	0		22.64	22.73	22.76
15	1	0	16-QAM	22.49	22.56	22.67
15	5	0		22.40	22.45	22.55
20	1	0	QPSK	22.98	22.93	22.85
20	6	0		22.91	22.82	22.76
20	1	0	16-QAM	22.74	22.74	22.59
20	5	0		22.61	22.64	22.39

**General Note:**

1. Anritsu CMW500 base station simulator was used to setup the connection with EUT; the frequency band, channel bandwidth, RB allocation configuration, modulation type are set in the base station simulator to configure EUT transmitting at maximum power and at different configurations which are requested to be reported to FCC, for conducted power measurement and SAR testing.
2. Per KDB 941225 D05, when a properly configured base station simulator is used for the SAR and power measurements, spectrum plots for each RB allocation and offset configuration is not required.
3. Per KDB 941225 D05, start with the largest channel bandwidth and measure SAR for QPSK with 1 RB allocation, using the RB offset and required test channel combination with the highest maximum output power for RB offsets at the upper edge, middle and lower edge of each required test channel.
4. Per KDB 941225 D05, 50% RB allocation for QPSK SAR testing follows 1RB QPSK allocation procedure.
5. Per KDB 941225 D05, For QPSK with 100% RB allocation, SAR is not required when the highest maximum output power for 100 % RB allocation is less than the highest maximum output power in 50% and 1 RB allocations and the highest reported SAR for 1 RB and 50% RB allocation are ≤ 0.8 W/kg. Otherwise, SAR is measured for the highest output power channel; and if the reported SAR is > 1.45 W/kg, the remaining required test channels must also be tested.
6. Per KDB 941225 D05, 16QAM output power for each RB allocation configuration is $>$ not $\frac{1}{2}$ dB higher than the same configuration in QPSK and the reported SAR for the QPSK configuration is ≤ 1.45 W/kg; Per KDB 941225 D05, 16QAM SAR testing is not required.
7. Per KDB 941225 D05, Smaller bandwidth output power for each RB allocation configuration is $>$ not $\frac{1}{2}$ dB higher than the same configuration in the largest supported bandwidth, and the reported SAR for the largest supported bandwidth is ≤ 1.45 W/kg; Per KDB 941225 D05, smaller bandwidth SAR testing is not required.

10. EUT and Test Setup Photo

10.1 EUT Photo

Front side



Back side

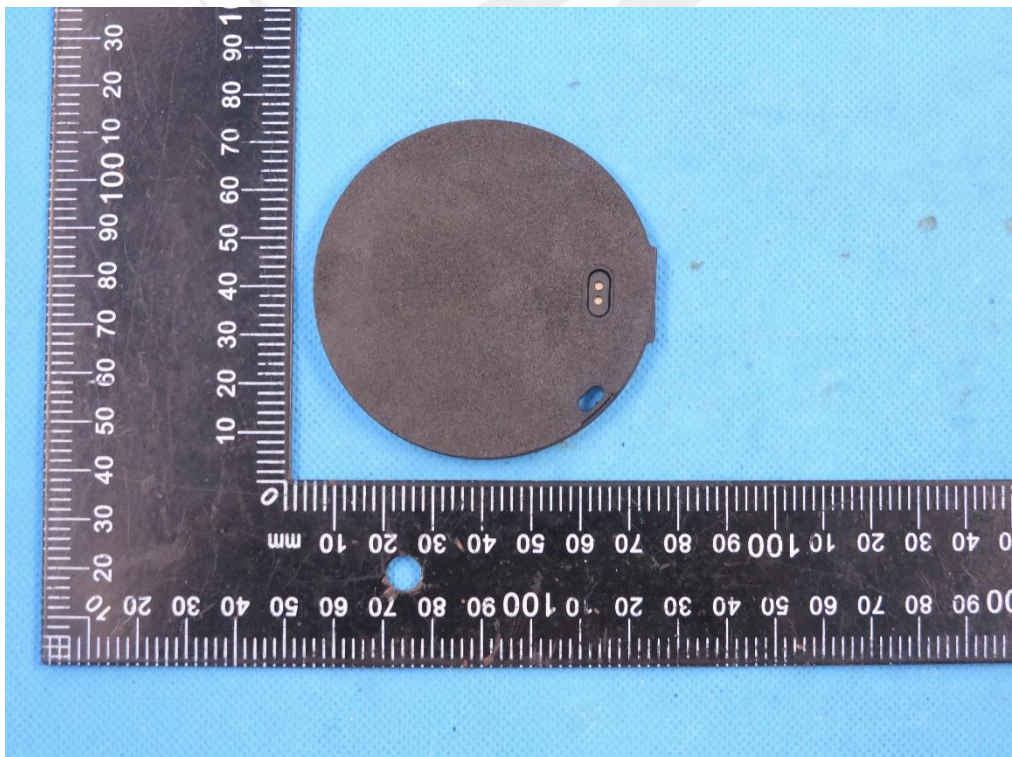



Top side

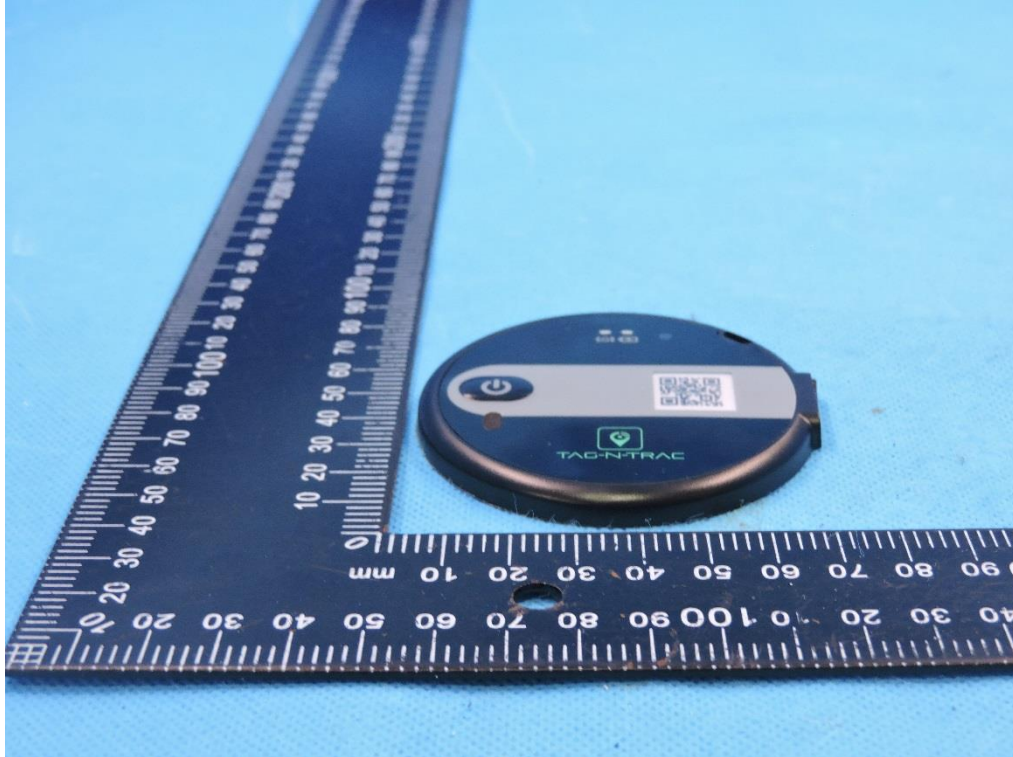

Bottom side



Left side

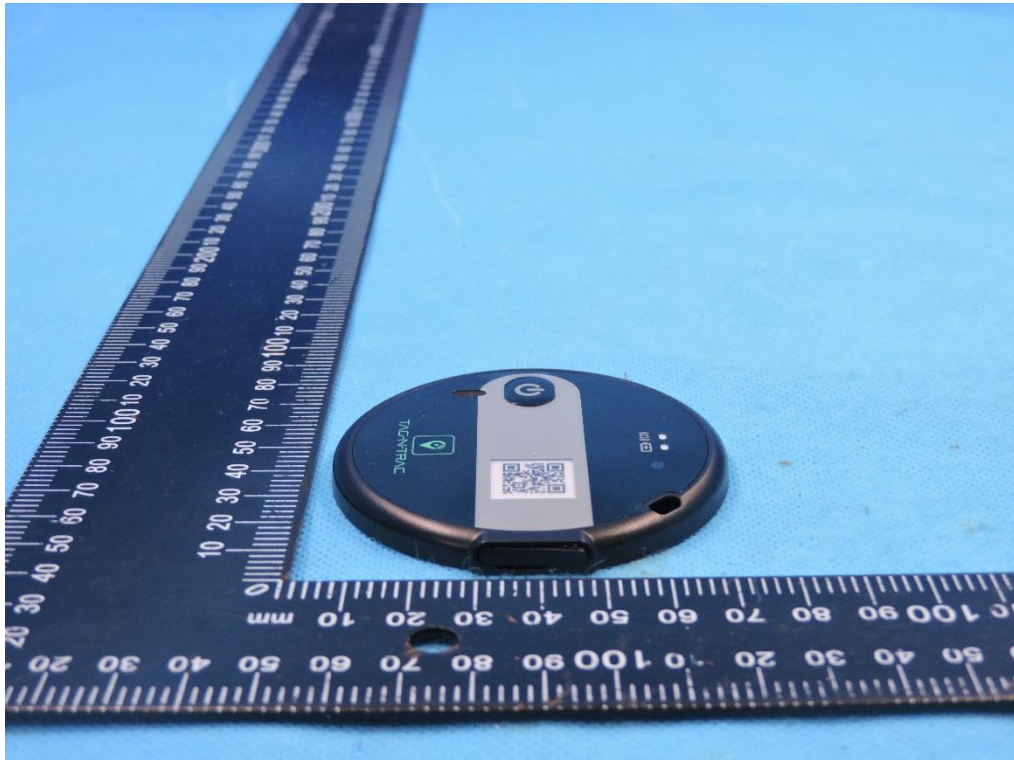

Right side

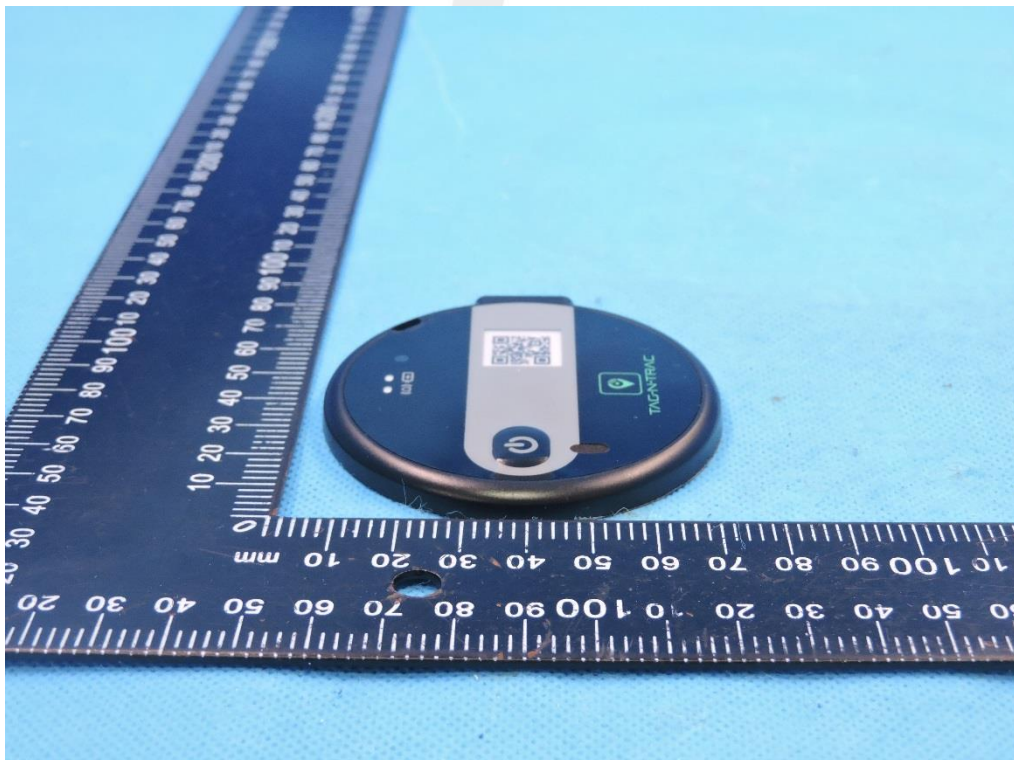

10.2 Setup Photo

Body Front side(separation distance is 5mm)

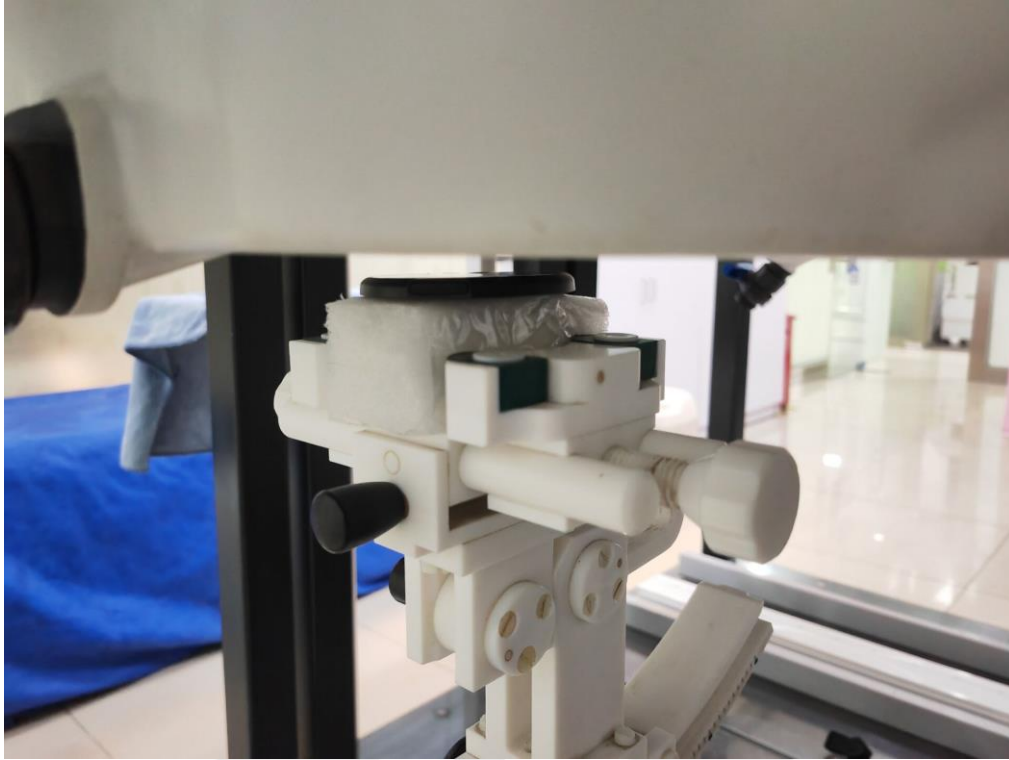

Body Back side(separation distance is 5mm)

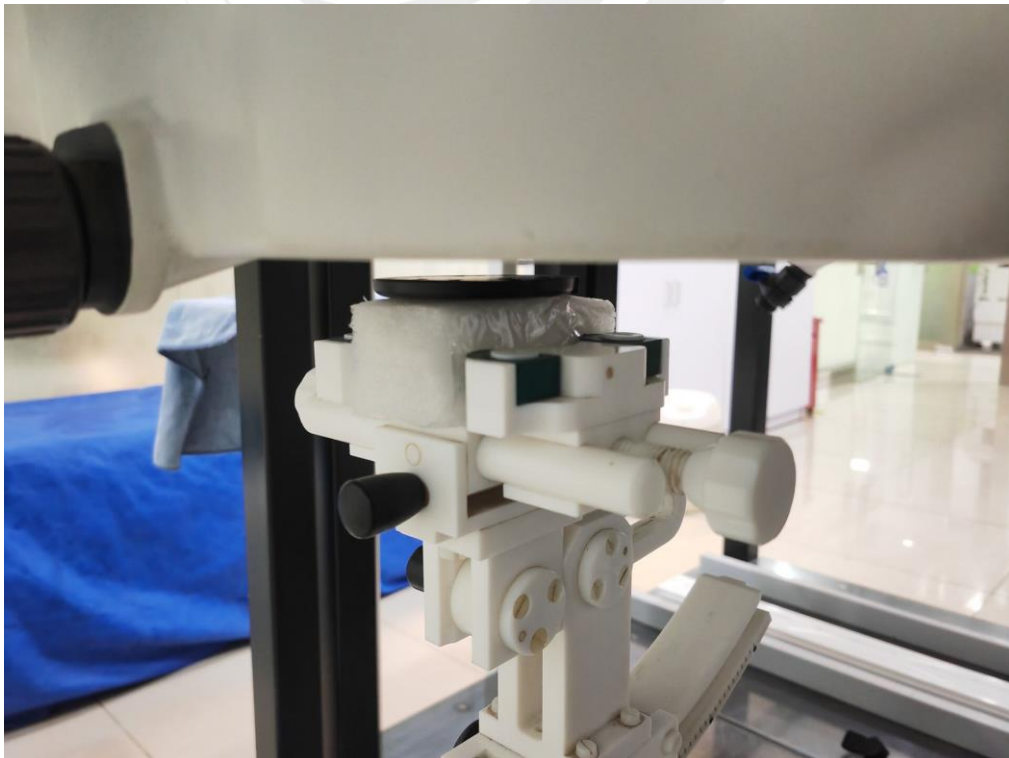



11. SAR Result Summary

11.1 Body-worn SAR

Band	BW (MHz)	Mod.	RB Size	RB offset	Test Position	Freq.	Result 1g (W/Kg)	Power Drift (%)	Max. Turn-up Power (dBm)	Meas. Output Power (dBm)	Scaled SAR (W/Kg)	Meas. No.
CAT-M Band 2	20M	QPSK	1	0	Front side	1880	0.450	0.66	23	22.93	0.457	/
			6	0	Front side	1880	0.435	3.56	23	22.82	0.453	/
			1	0	Back Side	1880	0.573	2.21	23	22.93	0.582	1
			6	0	Back Side	1880	0.521	-1.48	23	22.82	0.543	/
CAT-M Band 4	20M	QPSK	1	0	Front side	1720	0.355	-0.16	23	22.57	0.392	/
			6	0	Front side	1720	0.581	3.00	23	22.52	0.649	/
			1	0	Back Side	1720	0.605	-0.28	23	22.57	0.668	2
			1	0	Back Side	1732.5	0.514	-2.17	23	22.46	0.582	/
			1	0	Back Side	1745	0.501	1.44	23	22.43	0.571	/
			6	0	Back Side	1720	0.457	2.22	23	22.52	0.510	/
CAT-M Band 12	10M	QPSK	1	0	Front side	704	0.215	-1.63	23	22.68	0.231	/
			6	0	Front side	704	0.198	-3.97	23	22.67	0.214	/
			1	0	Back Side	704	0.323	2.29	23	22.68	0.348	3
			6	0	Back Side	704	0.214	0.42	23	22.67	0.231	/
CAT-M Band 13	10M	QPSK	1	0	Front side	782	0.360	0.47	23	22.69	0.387	4
			6	0	Front side	782	0.269	-0.58	23	22.53	0.300	/
			1	0	Back Side	782	0.348	3.10	23	22.69	0.374	/
			6	0	Back Side	782	0.258	0.13	23	22.53	0.287	/
CAT-M Band 25	20M	QPSK	1	0	Front side	1860	0.404	3.04	23	22.98	0.406	/
			6	0	Front side	1860	0.365	-0.05	23	22.91	0.373	/
			1	0	Back Side	1860	0.550	3.70	23	22.98	0.553	5
			6	0	Back Side	1860	0.514	-0.42	23	22.91	0.525	/

Note:

1. The test separation of all above table is 5mm.
2. Per KDB 447498 D04, the reported SAR is the measured SAR value adjusted for maximum tune-up tolerance.
 - a. Tune-up scaling Factor = tune-up limit power (mW) / EUT RF power (mW), where tune-up limit is the maximum rated power among all production units.
 - b. For WWAN: Scaled SAR(W/kg)= Measured SAR(W/kg)*Tune-up Scaling Factor



12. Equipment List

Kind of Equipment	Manufacturer	Type No.	Serial No.	Last Calibration	Calibrated Until
750MHz Dipole	MVG	SID750	SN 30/14 DIP0G750-331	2020.07.14	2023.07.13
1800MHz Dipole	MVG	SID1800	SN 30/14 DIP1G800-329	2020.07.14	2023.07.13
1900MHz Dipole	MVG	SID1900	SN 30/14 DIP1G900-333	2020.07.14	2023.07.13
E-Field Probe	MVG	SSE2	SN 07/21 EPM0352	2022.02.28	2023.02.27
Dielectric Probe Kit	MVG	SCLMP	SN 32/14 OCPG67	2021.11.23	2022.11.22
Antenna	MVG	ANTA3	SN 07/13 ZNTA52	N/A	N/A
Phantom1	MVG	SAM	SN 32/14 SAM115	N/A	N/A
Phantom3	MVG	SAM	SN 21/21 ELLI48	N/A	N/A
Phone holder	MVG	N/A	SN 32/14 MSH97	N/A	N/A
Laptop holder	MVG	N/A	SN 32/14 LSH29	N/A	N/A
Attenuator	Agilent	99899	DC-18GHz	N/A	N/A
Directional coupler	Narda	4226-20	3305	N/A	N/A
Network Analyzer	Agilent	8753ES	US38432810	2021.09.29	2022.09.28
Multi Meter	Keithley	Multi Meter 2000	4050073	2021.10.08	2022.10.07
Signal Generator	Agilent	N5182A	MY50140530	2021.09.30	2022.09.29
Wireless Communication Test Set	Agilent	8960-E5515C	MY48360751	2021.09.30	2022.09.29
Wireless Communication Test Set	R&S	CMW500	117239	2021.09.30	2022.09.29
Power Amplifier	DESAY	ZHL-42W	9638	2021.10.09	2022.10.08
Power Meter	R&S	NRP	100510	2021.09.29	2022.09.28
Power Sensor	R&S	NRP-Z11	101919	2021.09.29	2022.09.28
Temperature hygrometer	SuWei	SW-108	N/A	2021.10.09	2022.10.08
Thermograph	Elitech	RC-4	S/N EF7176501537	2021.10.09	2022.10.08

Note:

Per KDB 865664 D01, Dipole SAR Validation Verification, STS LAB has adopted 3 years calibration intervals. On annual basis, every measurement dipole has been evaluated and is in compliance with the following criteria:

1. There is no physical damage on the dipole
2. System validation with specific dipole is within 10% of calibrated value Return-loss in within 20% of calibrated measurement



Appendix A. System Validation Plots

System Performance Check Data (750MHz)

Type: Phone measurement (Complete)

Area scan resolution: dx=8mm, dy=8mm

Zoom scan resolution: dx=8mm, dy=8mm, dz=5mm

Date of measurement: 2022-08-04

Experimental conditions

Phantom	Validation plane
Device Position	-
Band	750MHz
Channels	-
Signal	CW
Frequency (MHz)	750MHz
Relative permittivity	42.15
Conductivity (S/m)	0.94
Probe	SN 07/21 EPGO352
ConvF	1.58
Crest factor	1:1

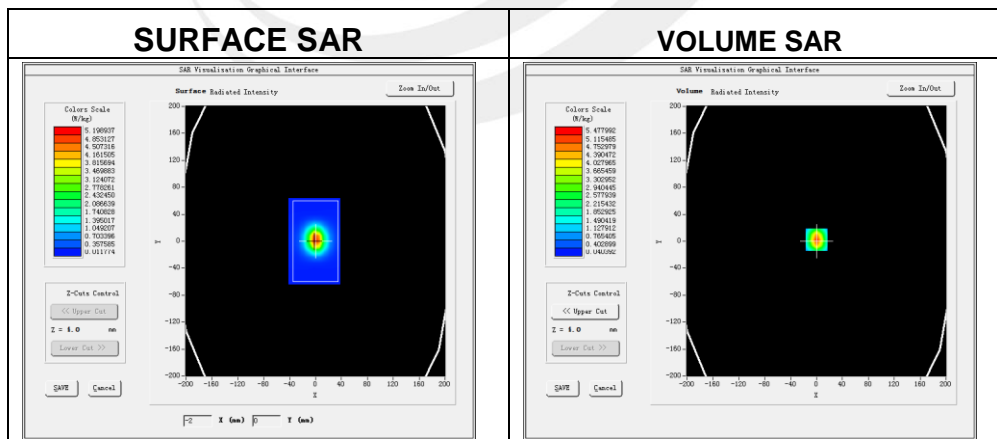

Maximum location: X=2.00, Y=1.00

SAR 10g (W/Kg)	0.543143
SAR 1g (W/Kg)	0.860829

Z Axis Scan

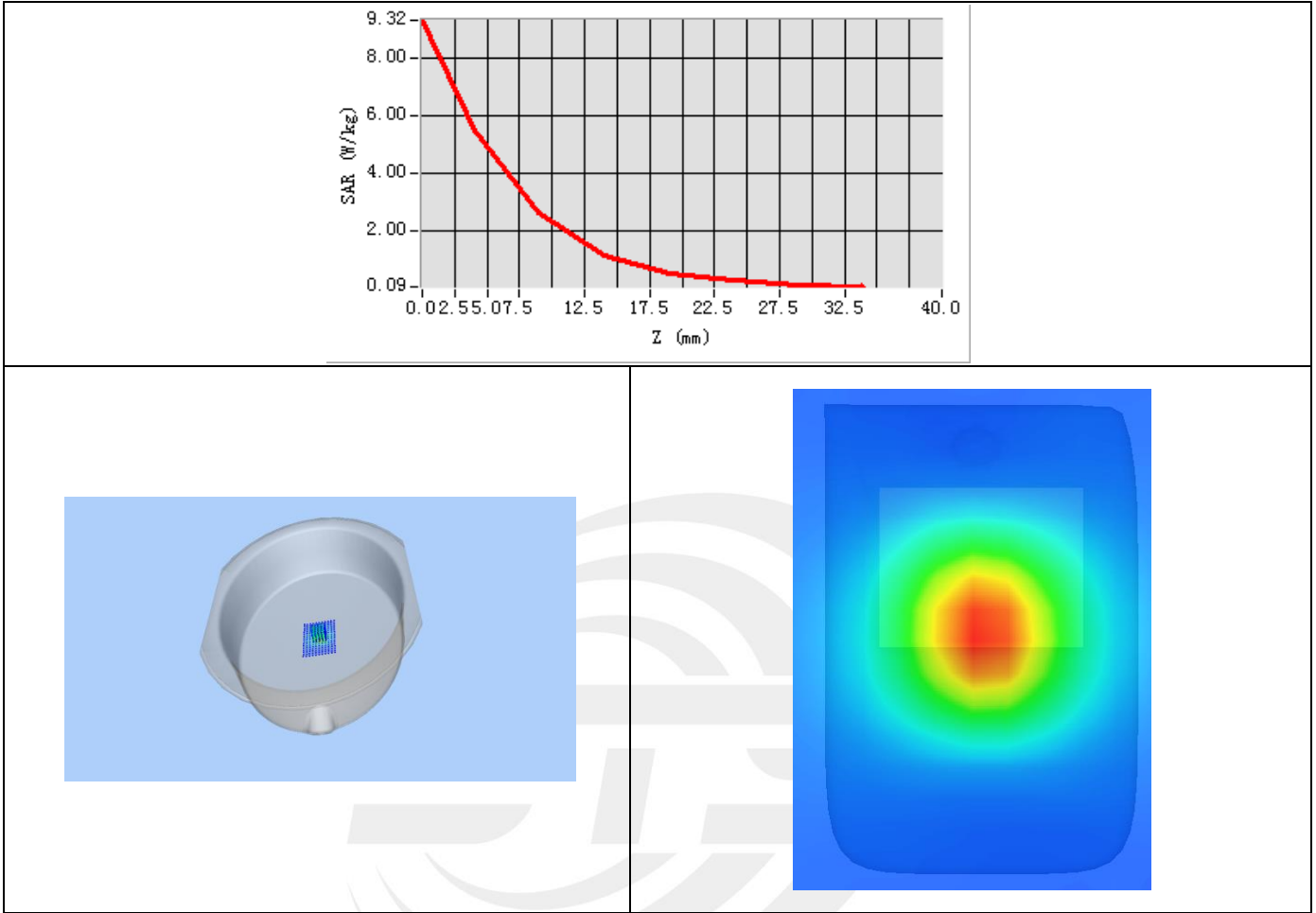



System Performance Check Data (1800MHz)

Type: Phone measurement (Complete)
 Area scan resolution: dx=8mm, dy=8mm
 Zoom scan resolution: dx=8mm, dy=8mm, dz=5mm
 Date of measurement: 2022-08-04

Experimental conditions.

Phantom	Validation plane
Device Position	-
Band	1800MHz
Channels	-
Signal	CW
Frequency (MHz)	1800MHz
Relative permittivity	40.64
Conductivity (S/m)	1.42
Probe	SN 07/21 EPGO352
ConvF	1.60
Crest factor:	1:1

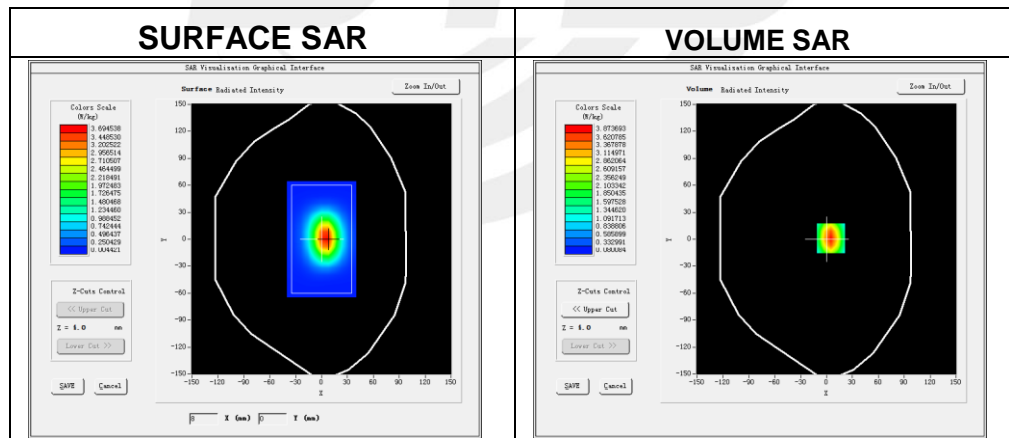

Maximum location: X=5.00, Y=1.00

SAR 10g (W/Kg)	2.025210
SAR 1g (W/Kg)	3.859031

Z Axis Scan

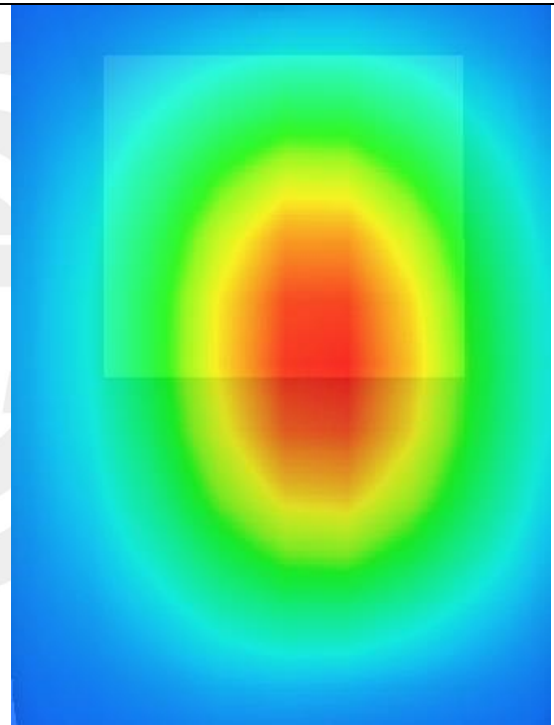
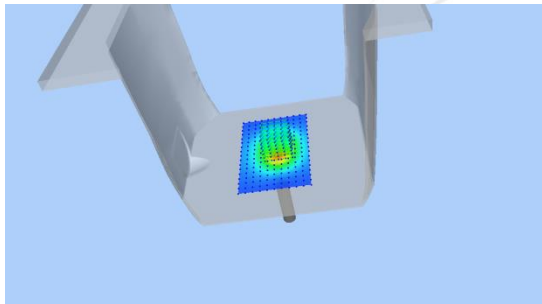
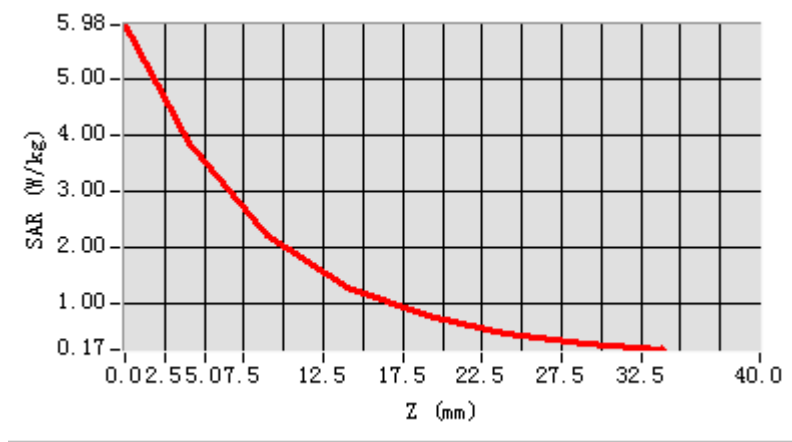



System Performance Check Data (1900MHz)

Type: Phone measurement (Complete)
 Area scan resolution: dx=8mm, dy=8mm
 Zoom scan resolution: dx=8mm, dy=8mm, dz=5mm
 Date of measurement: 2022-08-04

Experimental conditions.

Phantom	Validation plane
Device Position	-
Band	1900MHz
Channels	-
Signal	CW
Frequency (MHz)	1900MHz
Relative permittivity	40.40
Conductivity (S/m)	1.38
Probe	SN 07/21 EPGO352
ConvF	1.60
Crest factor:	1:1

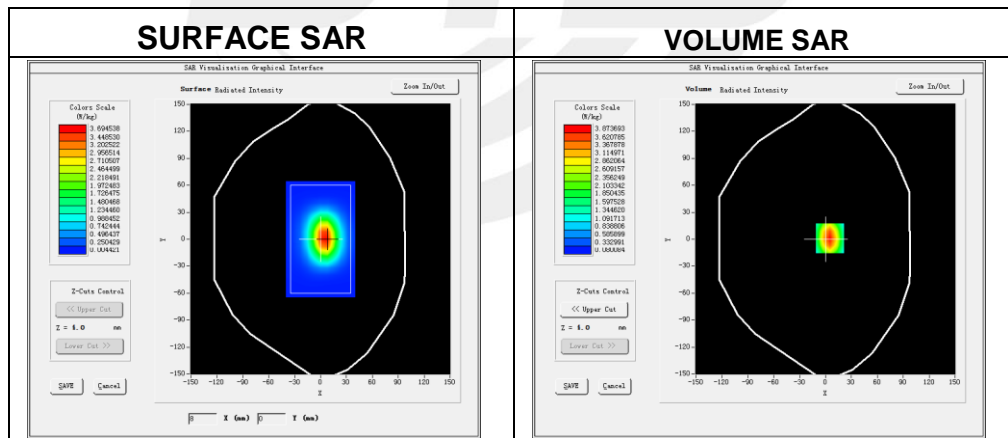

Maximum location: X=5.00, Y=1.00

SAR 10g (W/Kg)	2.085479
SAR 1g (W/Kg)	3.986429

Z Axis Scan

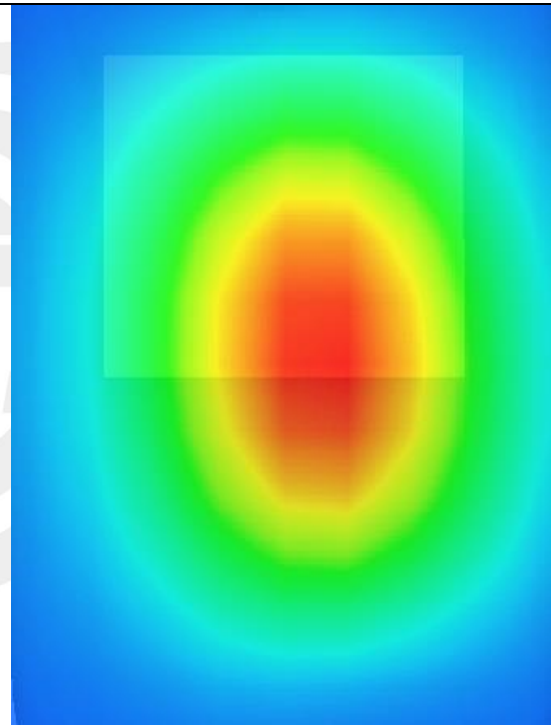
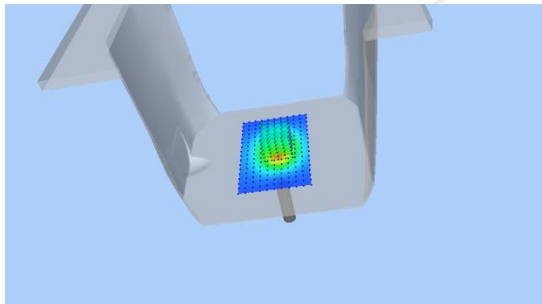
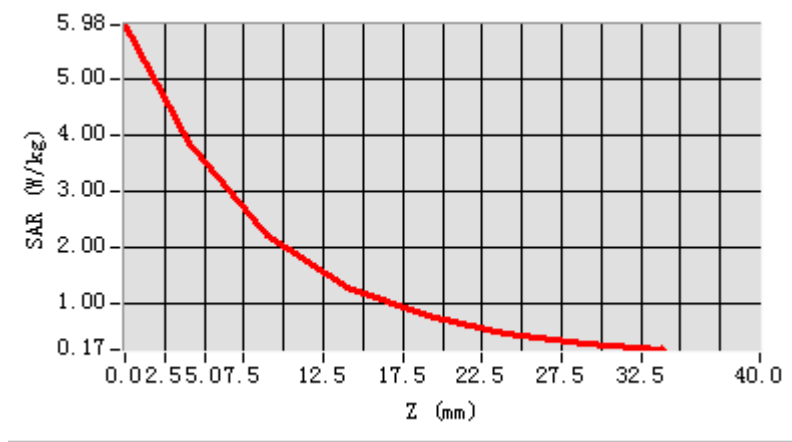

System Performance Check Data (1900MHz)

Type: Phone measurement (Complete)
 Area scan resolution: dx=8mm, dy=8mm
 Zoom scan resolution: dx=8mm, dy=8mm, dz=5mm
 Date of measurement: 2022-08-04

Experimental conditions.

Phantom	Validation plane
Device Position	-
Band	1900MHz
Channels	-
Signal	CW
Frequency (MHz)	1900MHz
Relative permittivity	40.21
Conductivity (S/m)	1.36
Probe	SN 07/21 EPGO352
ConvF	1.60
Crest factor:	1:1

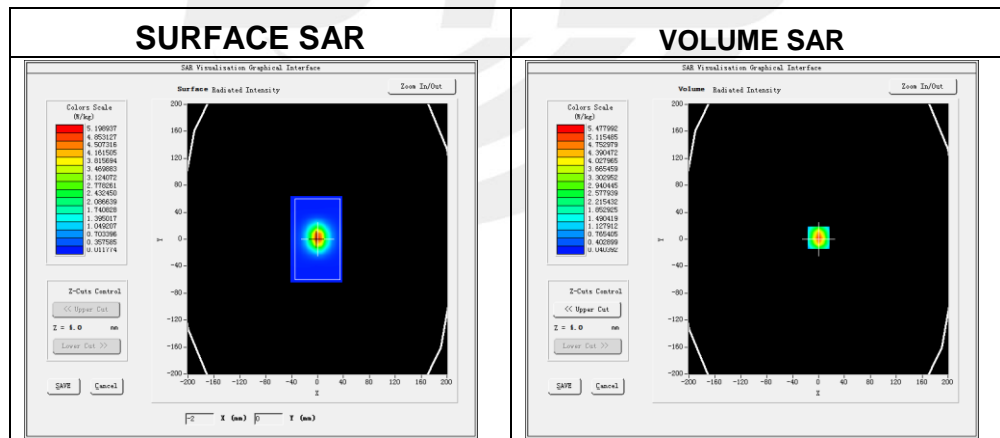

Maximum location: X=5.00, Y=1.00

SAR 10g (W/Kg)	2.075250
SAR 1g (W/Kg)	3.992143

Z Axis Scan

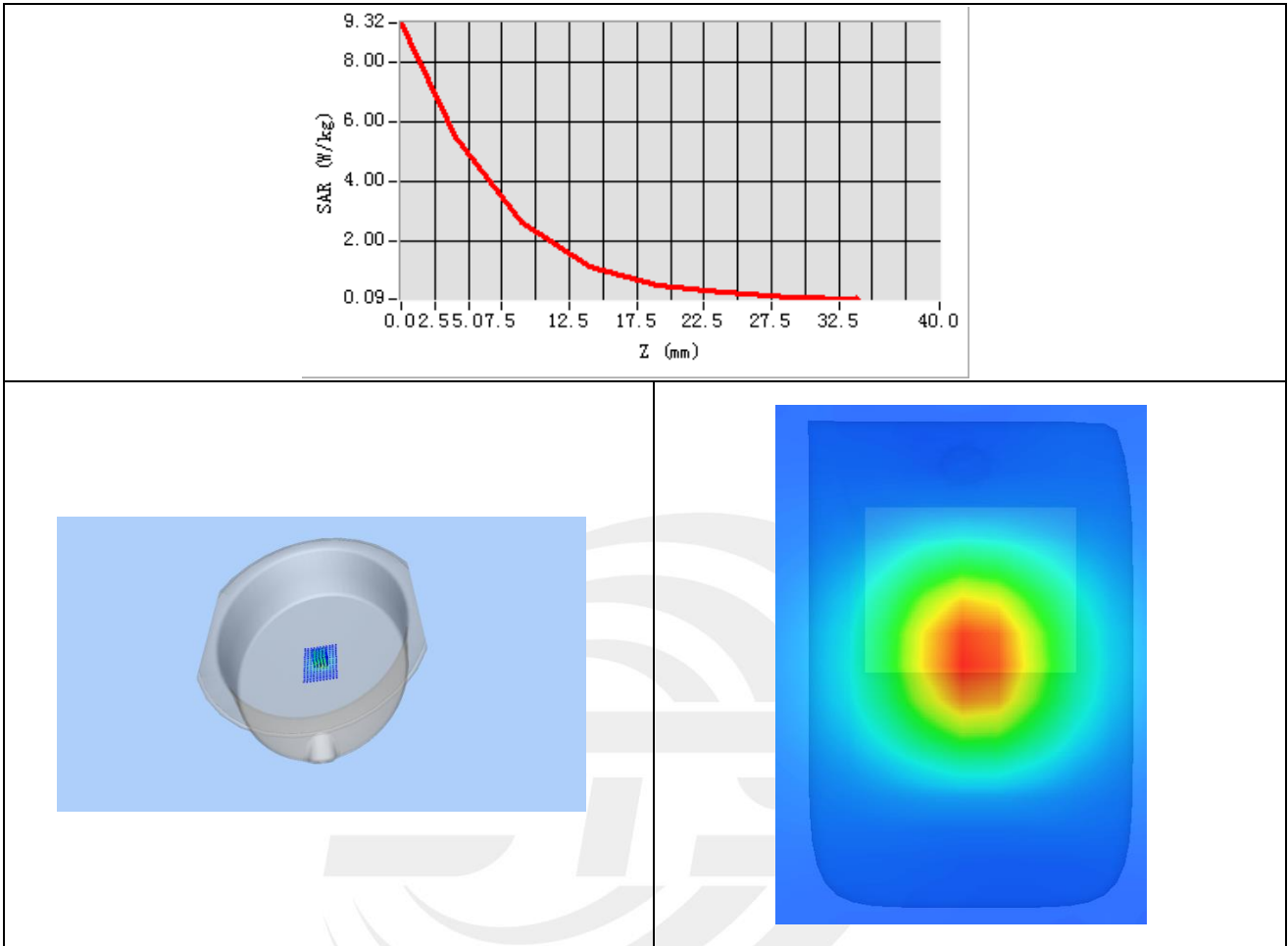

Appendix B. SAR Test Plots

Plot 1: DUT: Smart Sense Tag; EUT Model: ST100

Test Date	2022-08-04
Probe	SN 07/21 EPGO352
Area Scan	dx=8mm, dy=8mm, h= 5.00 mm
Zoom Scan	5x5x7, dx=8mm, dy=8mm, dz=5mm, Complete/ndx=8mm, dy=8mm, h= 5.00 mm
Phantom	Validation plane
Device Position	Back Side
Band	CAT-M Band 2(RB 1)
Signal	CAT-M (Crest factor: 1.0)
Frequency (MHz)	1880
Relative permittivity (real part)	40.28
Conductivity (S/m)	1.38

Maximum location: X=2.00, Y=22.00

SAR Peak: 0.91 W/kg

SAR 10g (W/Kg)	0.316226
SAR 1g (W/Kg)	0.573259

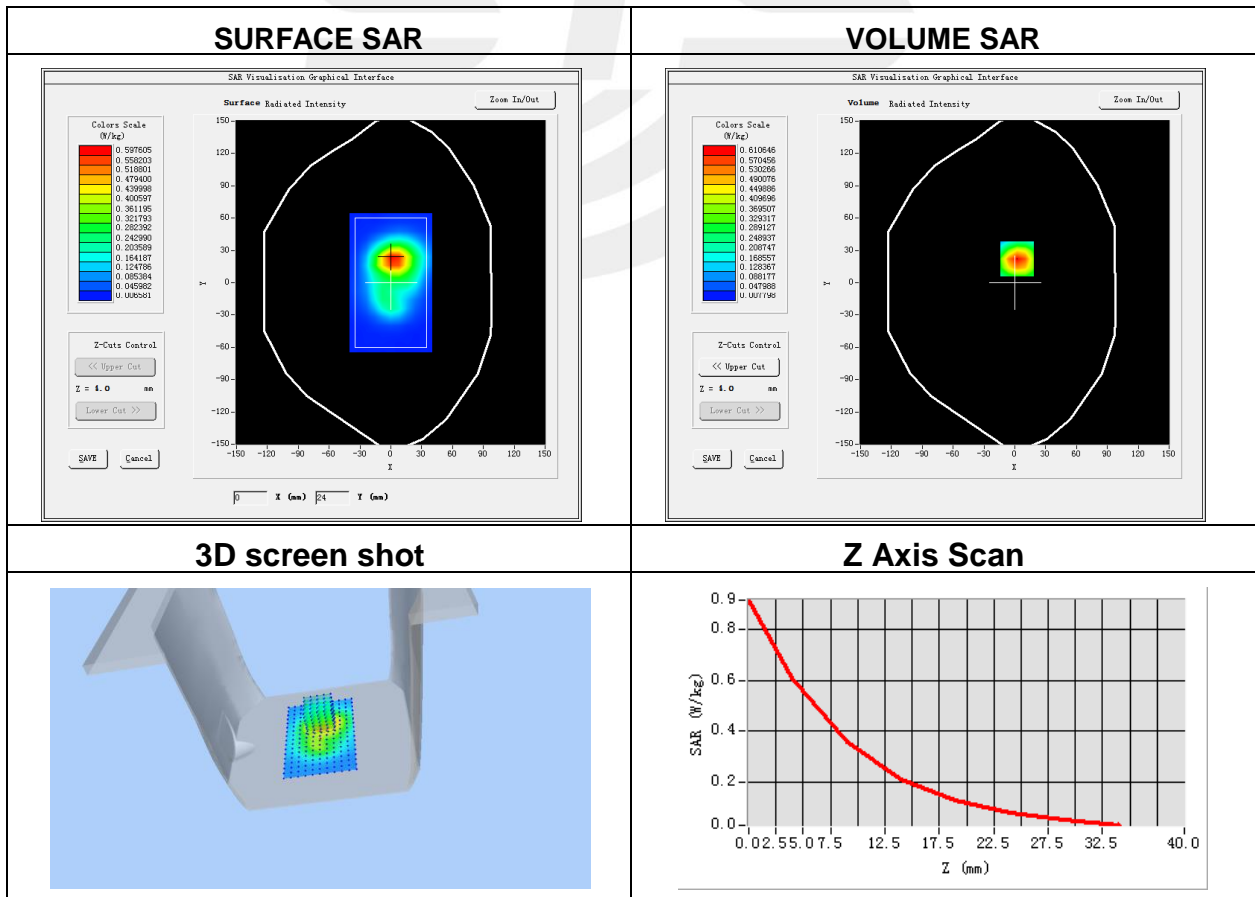

Plot 2: DUT: Smart Sense Tag; EUT Model: ST100

Test Date	2022-08-04
Probe	SN 07/21 EPGO352
Area Scan	dx=8mm, dy=8mm, h= 5.00 mm
Zoom Scan	5x5x7, dx=8mm, dy=8mm, dz=5mm, Complete/ndx=8mm, dy=8mm, h= 5.00 mm
Phantom	Validation plane
Device Position	Back Side
Band	CAT-M Band 4 (RB 1)
Signal	CAT-M (Crest factor: 1.0)
Frequency (MHz)	1720
Relative permittivity (real part)	40.16
Conductivity (S/m)	1.38

Maximum location: X=13.00, Y=-20.00
SAR Peak: 0.96 W/kg

SAR 10g (W/Kg)	0.339444
SAR 1g (W/Kg)	0.605497

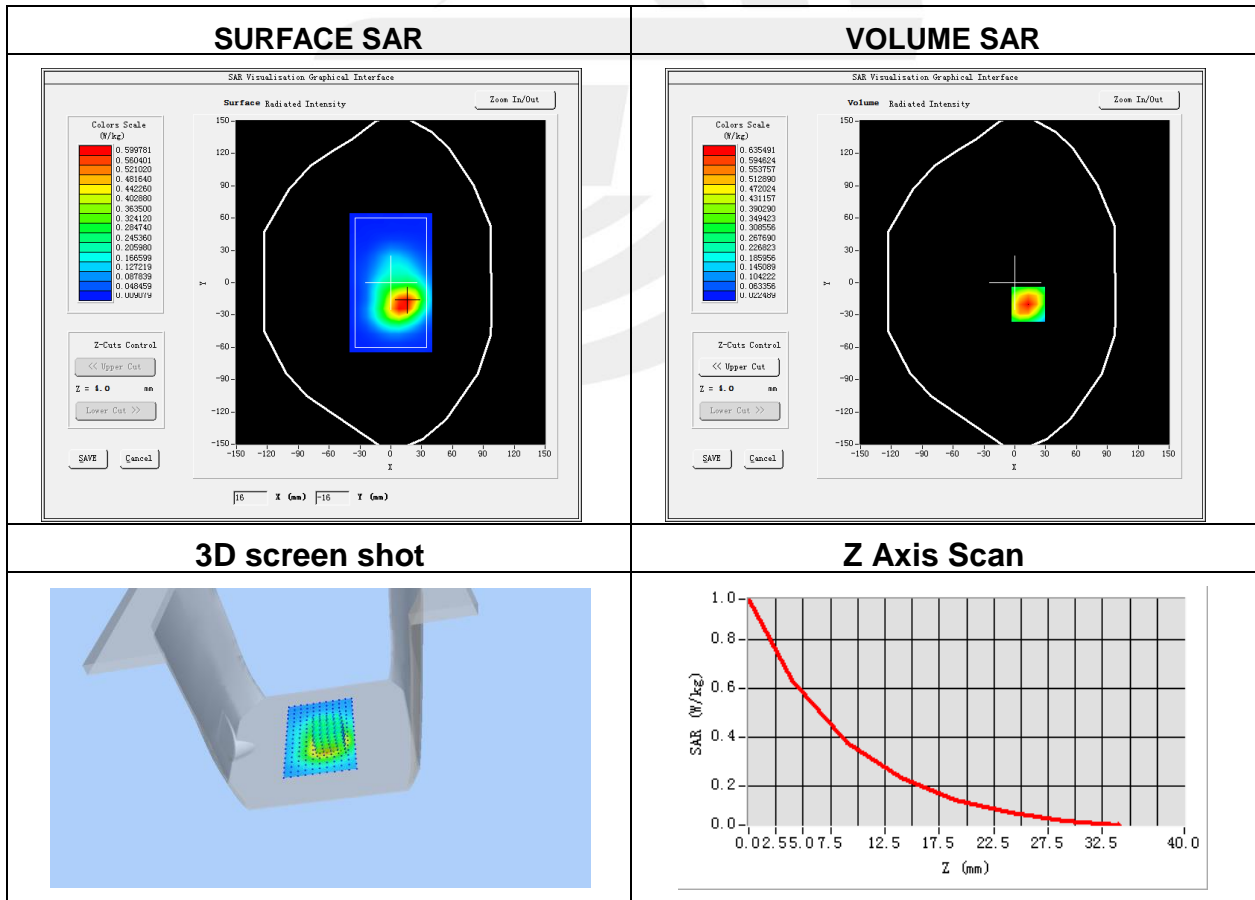

Plot 3: DUT: Smart Sense Tag; EUT Model: ST100

Test Date	2022-08-04
Probe	SN 07/21 EPGO352
Area Scan	dx=8mm, dy=8mm, h= 5.00 mm
Zoom Scan	5x5x7, dx=8mm, dy=8mm, dz=5mm, Complete/ndx=8mm, dy=8mm, h= 5.00 mm
Phantom	Validation plane
Device Position	Back Side
Band	CAT-M Band 12 (RB 1)
Signal	CAT-M (Crest factor: 1.0)
Frequency (MHz)	704
Relative permittivity (real part)	42.62
Conductivity (S/m)	0.88

Maximum location: X=30.00, Y=-8.00

SAR Peak: 0.51 W/kg

SAR 10g (W/Kg)	0.189051
SAR 1g (W/Kg)	0.323105

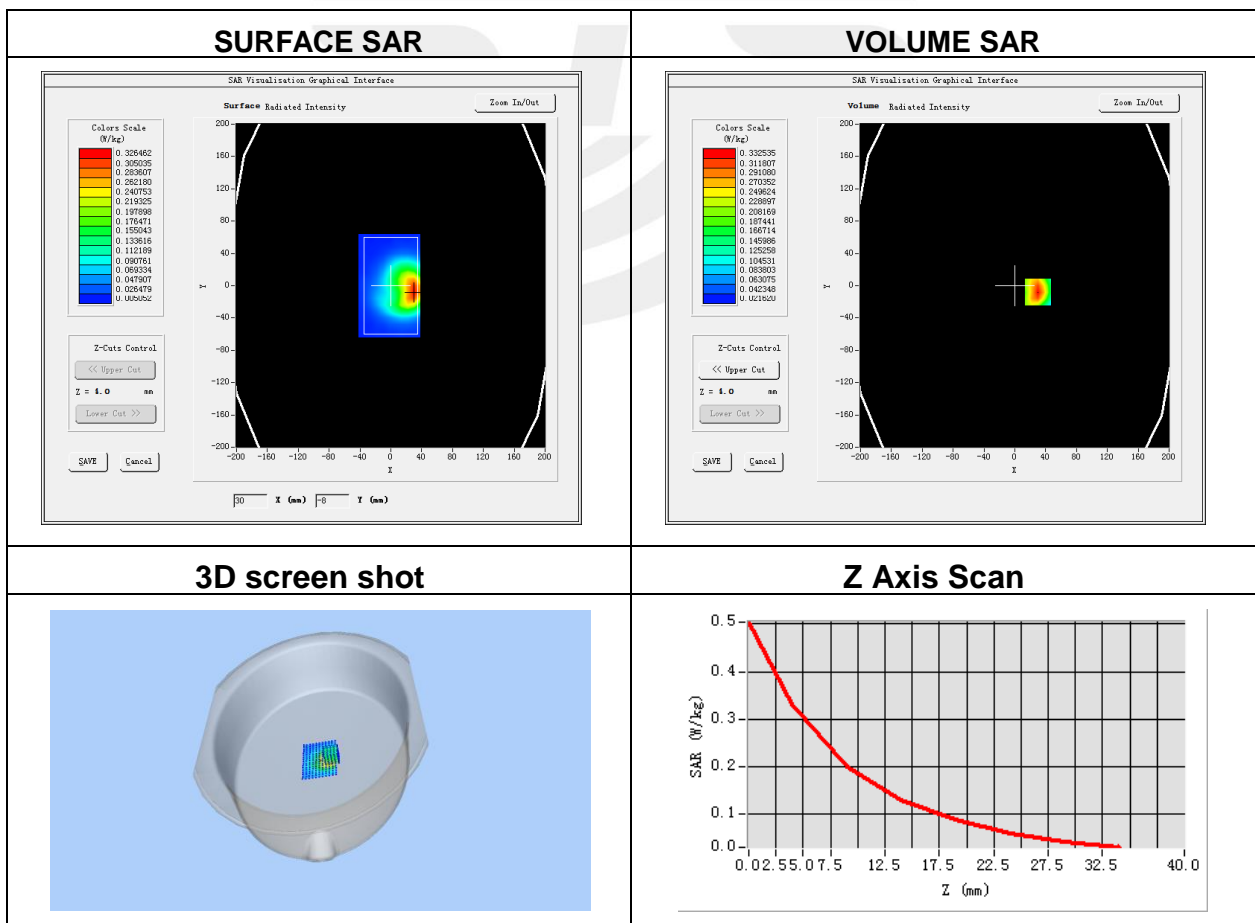

Plot 4: DUT: Smart Sense Tag; EUT Model: ST100

Test Date	2022-08-04
Probe	SN 07/21 EPGO352
Area Scan	dx=8mm, dy=8mm, h= 5.00 mm
Zoom Scan	5x5x7, dx=8mm, dy=8mm, dz=5mm, Complete/ndx=8mm, dy=8mm, h= 5.00 mm
Phantom	Validation plane
Device Position	Back Side
Band	CAT-M Band 13 (RB 1)
Signal	CAT-M (Crest factor: 1.0)
Frequency (MHz)	782
Relative permittivity (real part)	40.95
Conductivity (S/m)	0.88

Maximum location: X=24.00, Y=9.00

SAR Peak: 0.54 W/kg

SAR 10g (W/Kg)	0.217147
SAR 1g (W/Kg)	0.347831

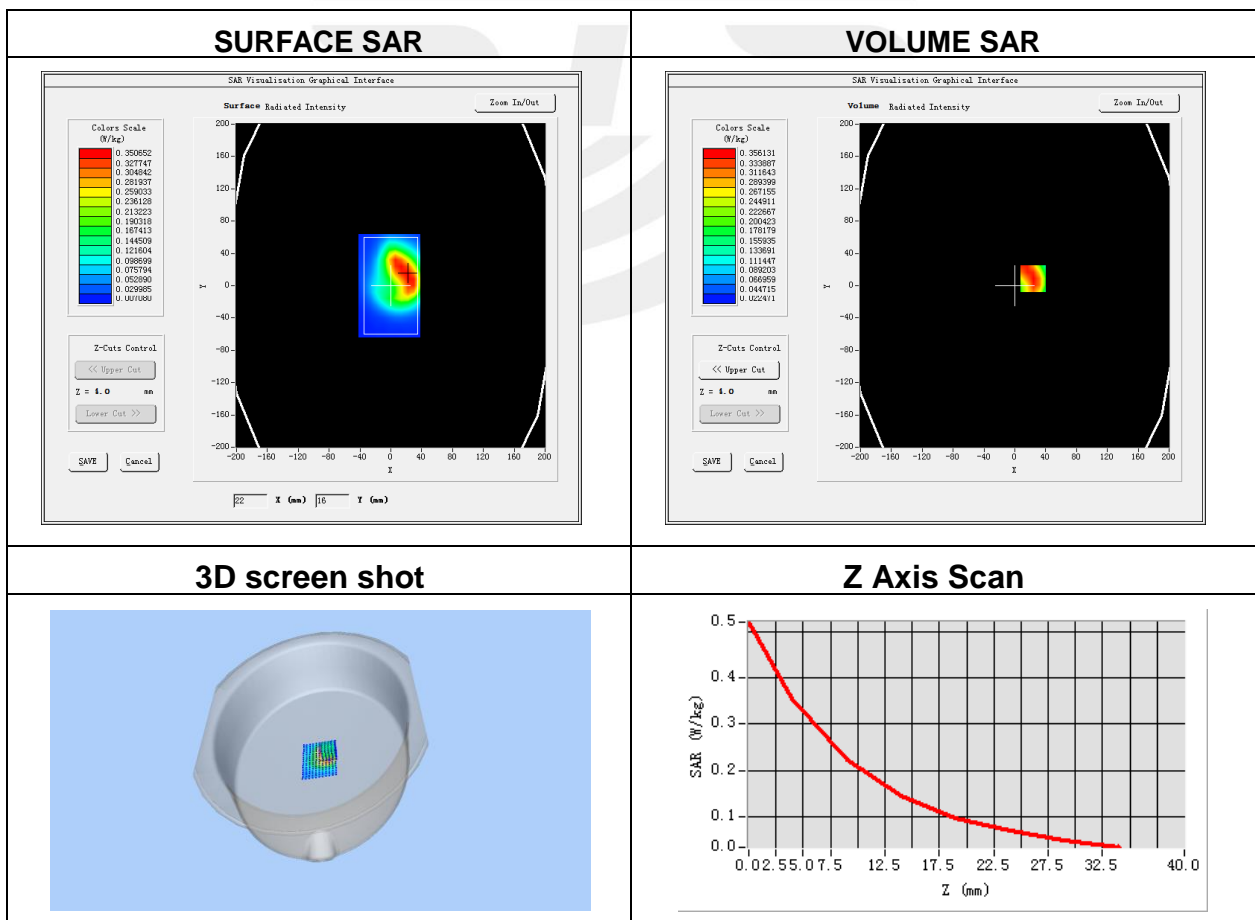

Plot 5: DUT: Smart Sense Tag; EUT Model: ST100

Test Date	2022-08-04
Probe	SN 07/21 EPGO352
Area Scan	dx=8mm, dy=8mm, h= 5.00 mm
Zoom Scan	5x5x7, dx=8mm, dy=8mm, dz=5mm, Complete/ndx=8mm, dy=8mm, h= 5.00 mm
Phantom	Validation plane
Device Position	Back Side
Band	CAT-M Band 25 (RB 1)
Signal	CAT-M (Crest factor: 1.0)
Frequency (MHz)	1860
Relative permittivity (real part)	40.42
Conductivity (S/m)	1.36

Maximum location: X=14.00, Y=-16.00

SAR Peak: 0.90 W/kg

SAR 10g (W/Kg)	0.290828
SAR 1g (W/Kg)	0.550109

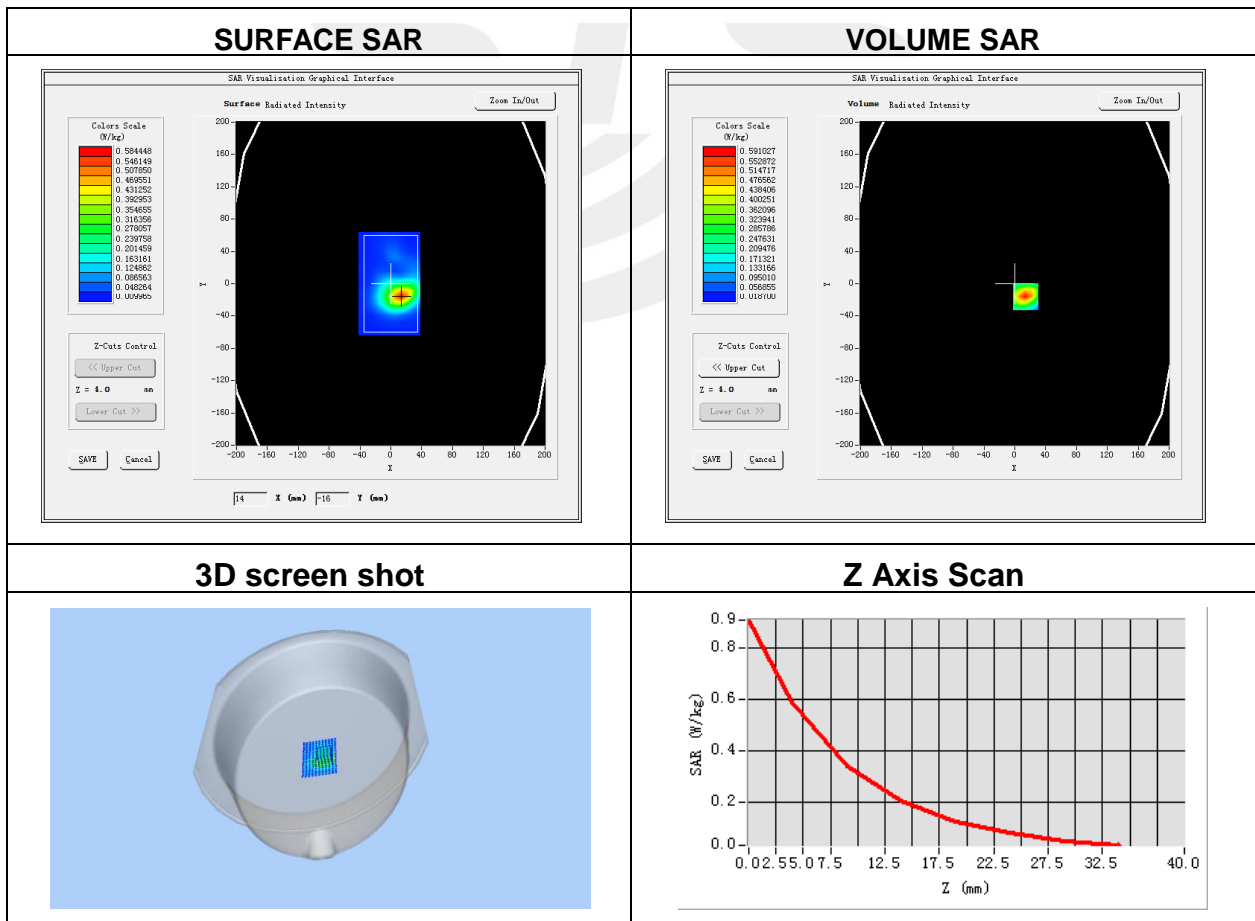



Appendix C. Probe Calibration and Dipole Calibration Report

Refer the appendix Calibration Report.

※※※※END OF THE REPORT※※※※

