

11AC80MIMO\_Ant1\_5210

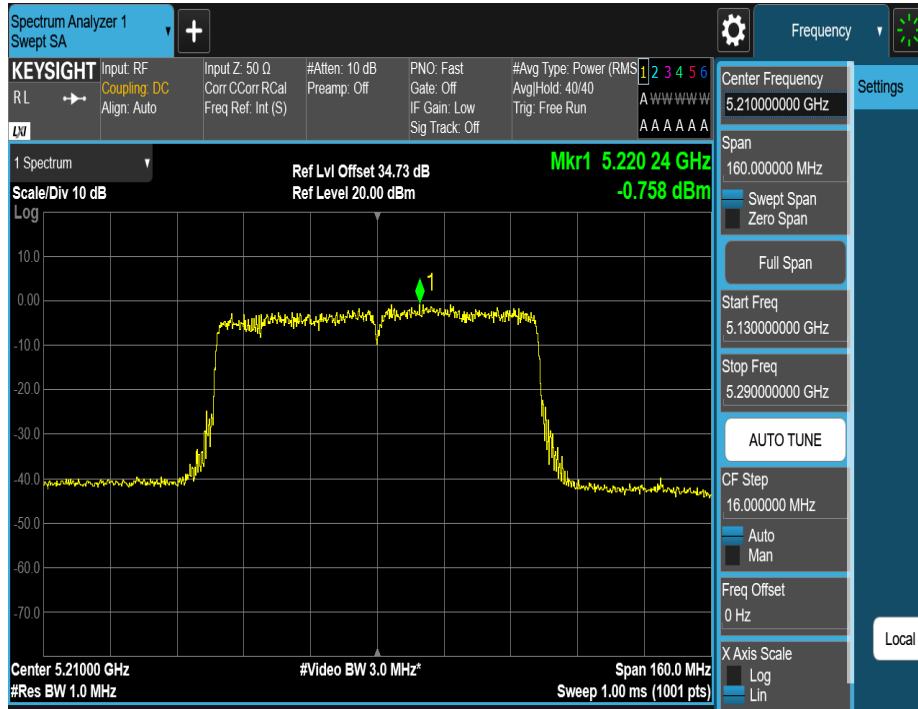

11AC80MIMO\_Ant2\_5210

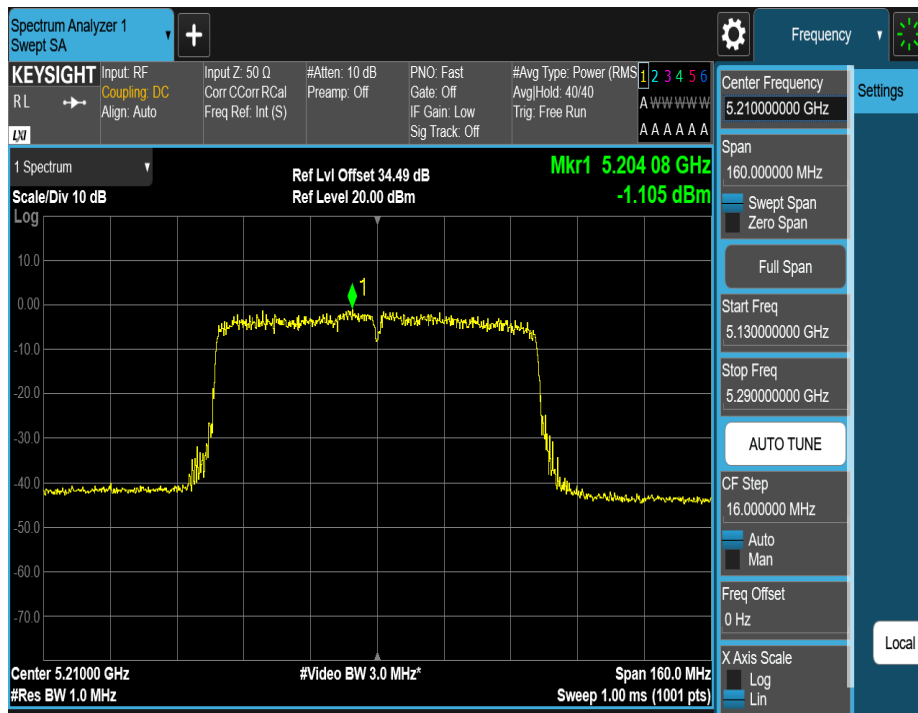

11AC80MIMO\_Ant1\_5290

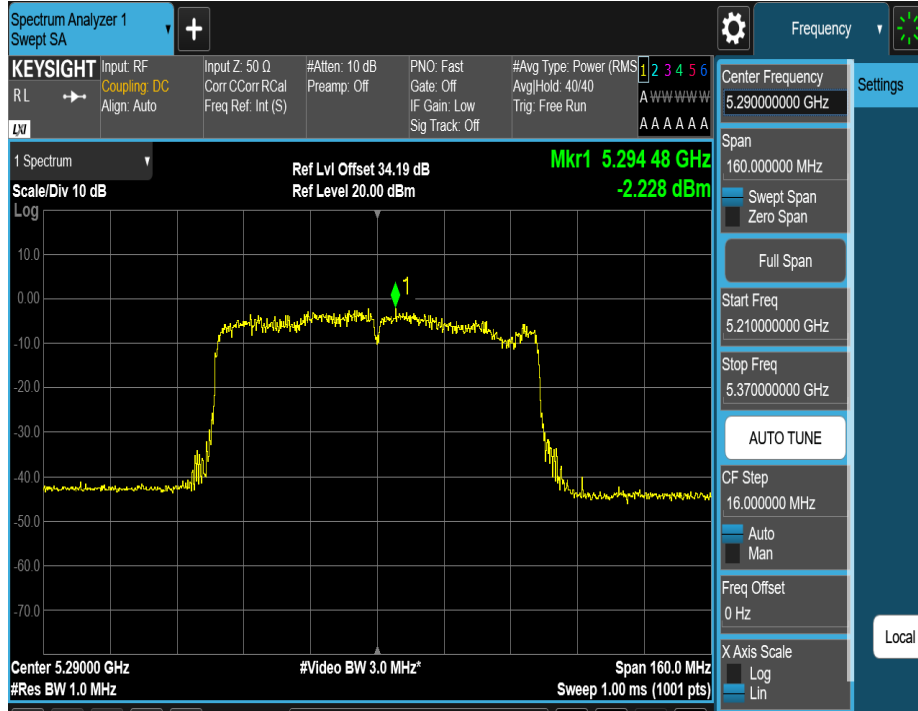

11AC80MIMO\_Ant2\_5290

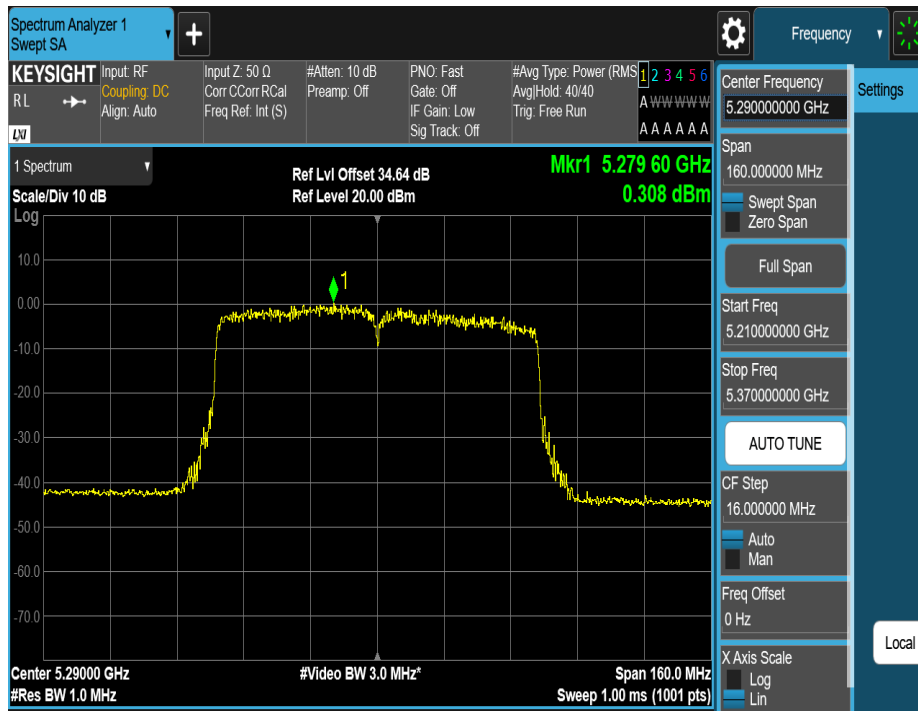

11AC80MIMO\_Ant1\_5530

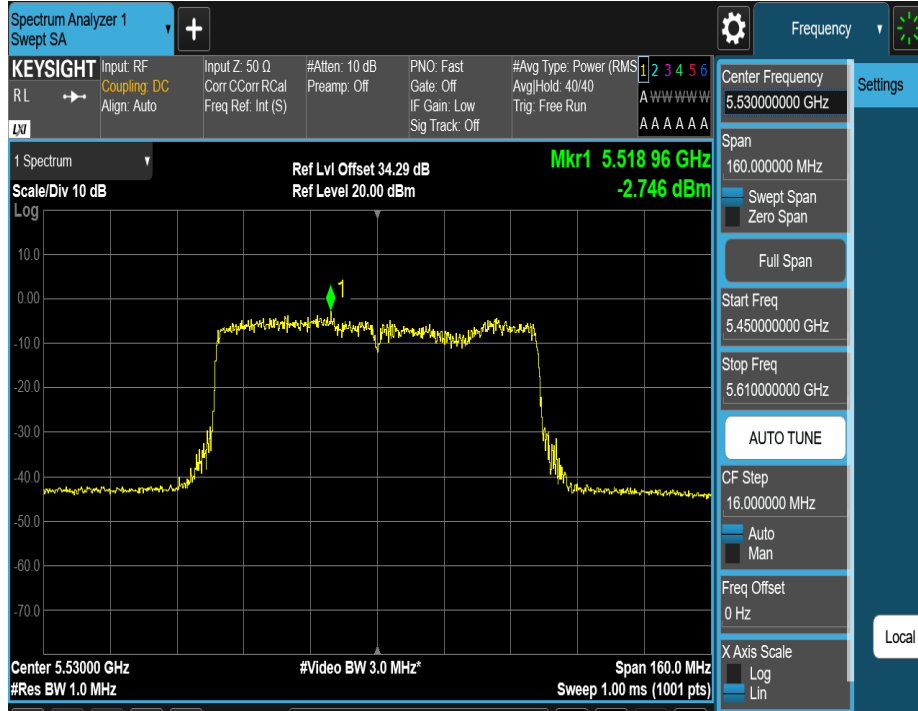

11AC80MIMO\_Ant2\_5530

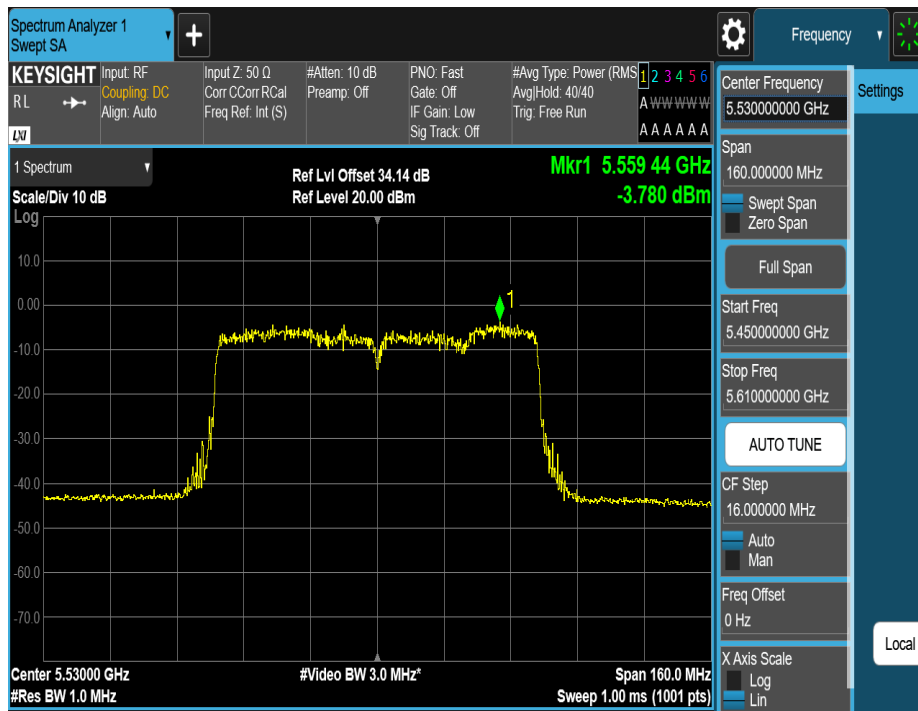

11AC80MIMO\_Ant1\_5610

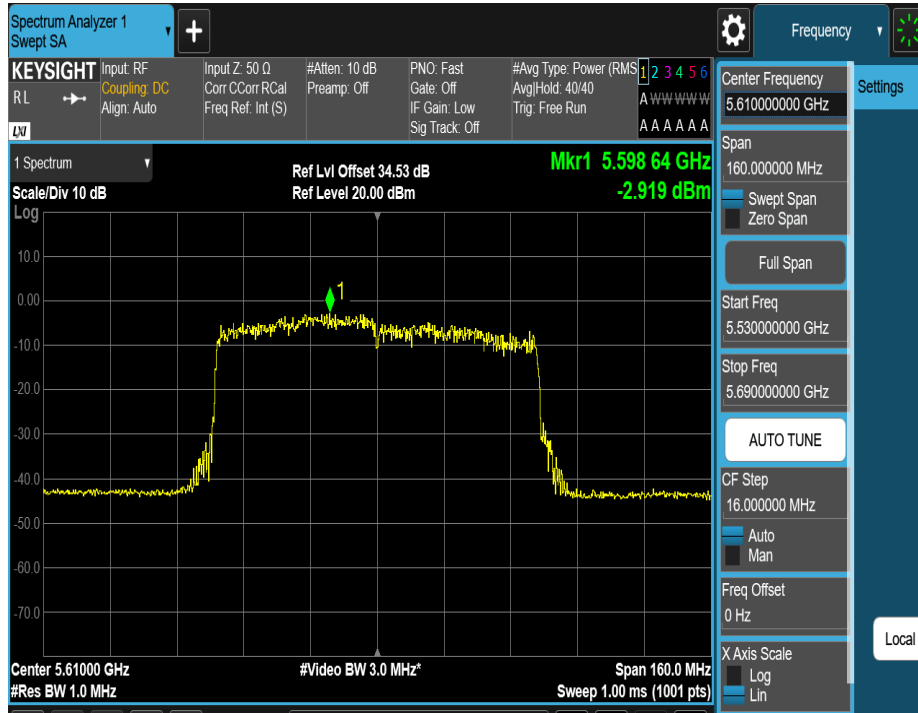

11AC80MIMO\_Ant2\_5610

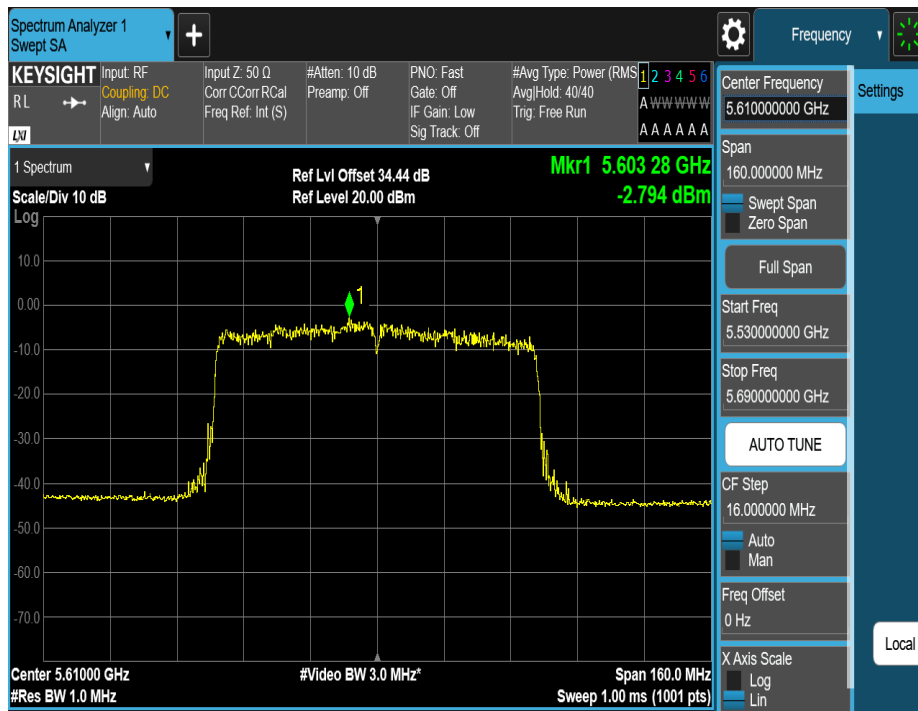

11AC80MIMO\_Ant1\_5775

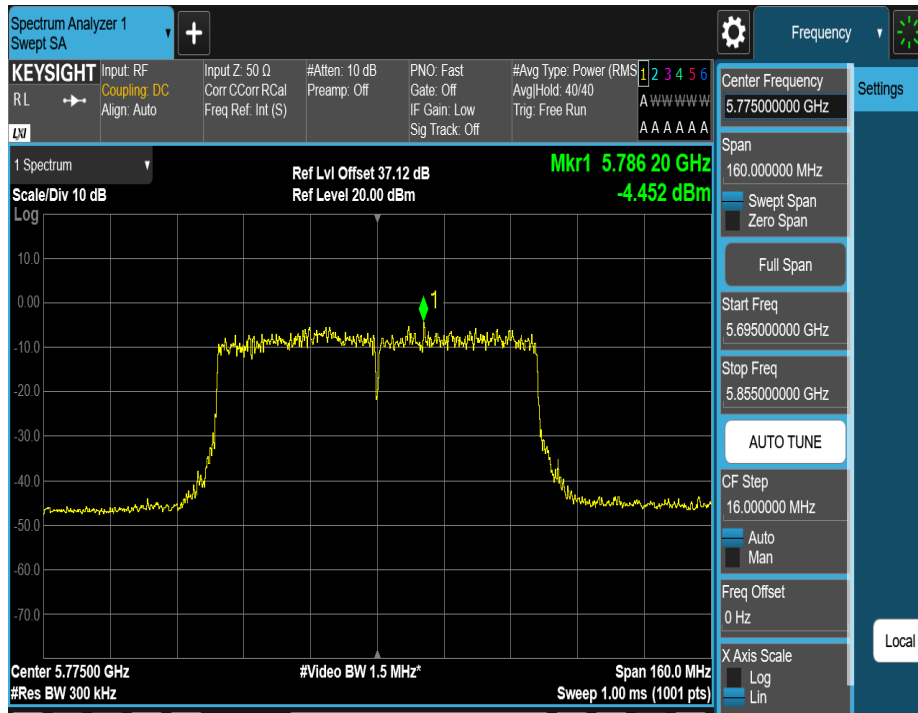

11AC80MIMO\_Ant2\_5775

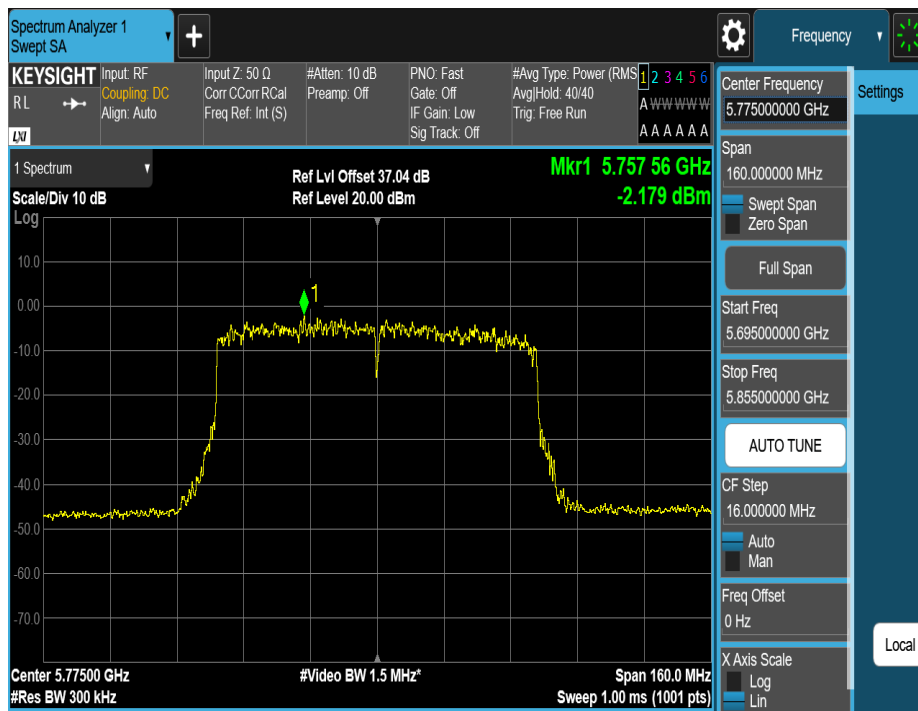

11AX20MIMO\_Ant1\_5180

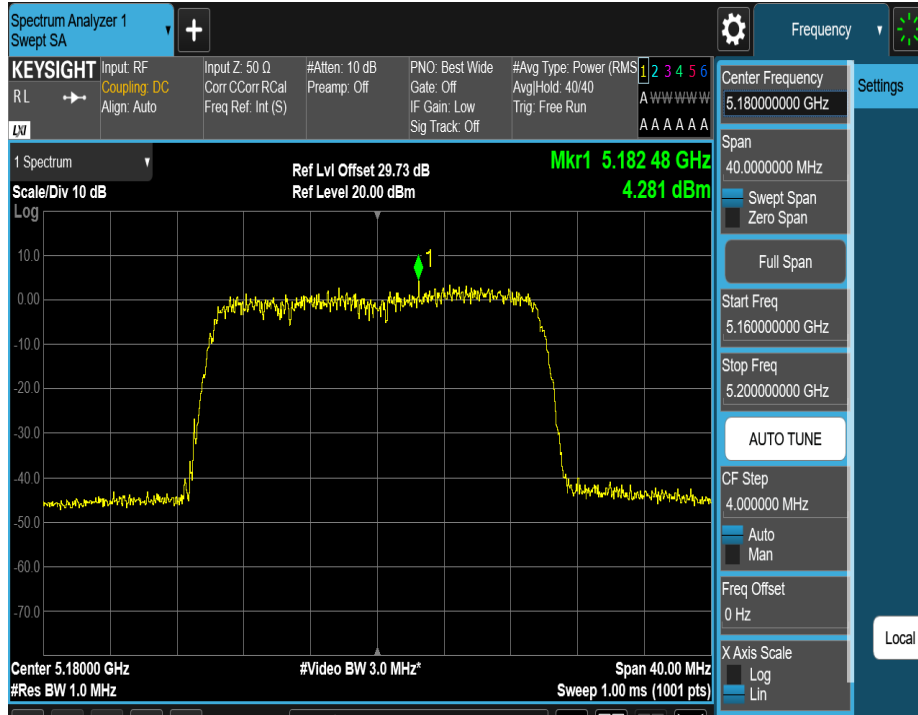

11AX20MIMO\_Ant2\_5180

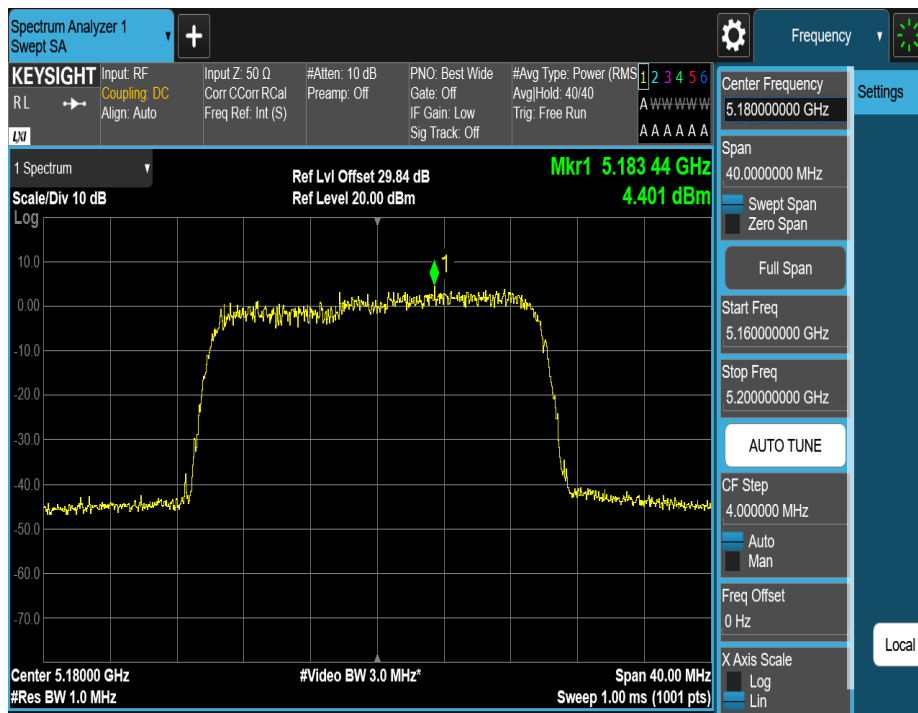

11AX20MIMO\_Ant1\_5200

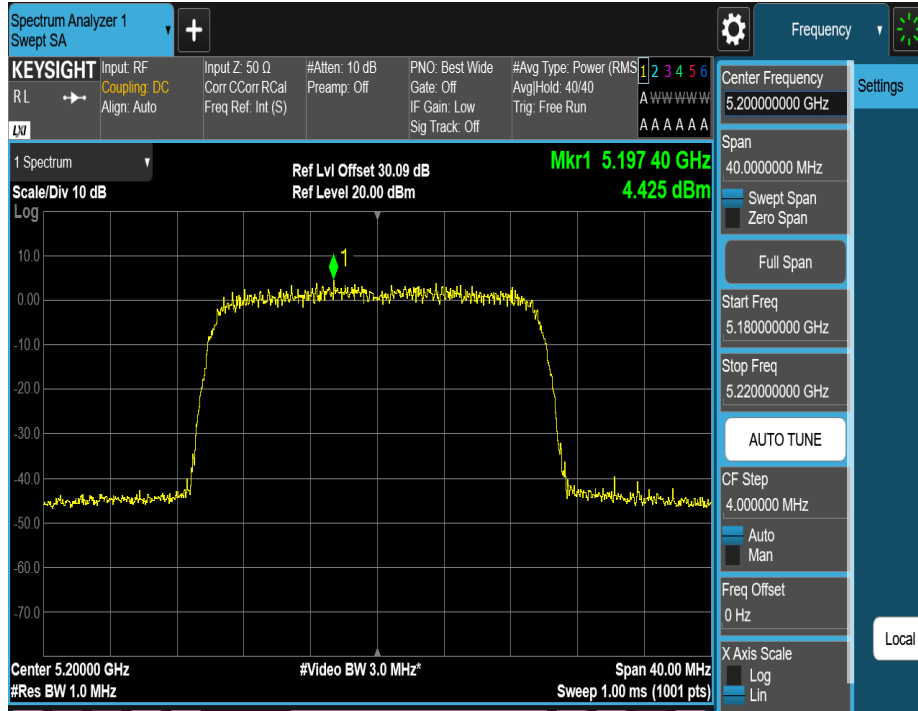

11AX20MIMO\_Ant2\_5200

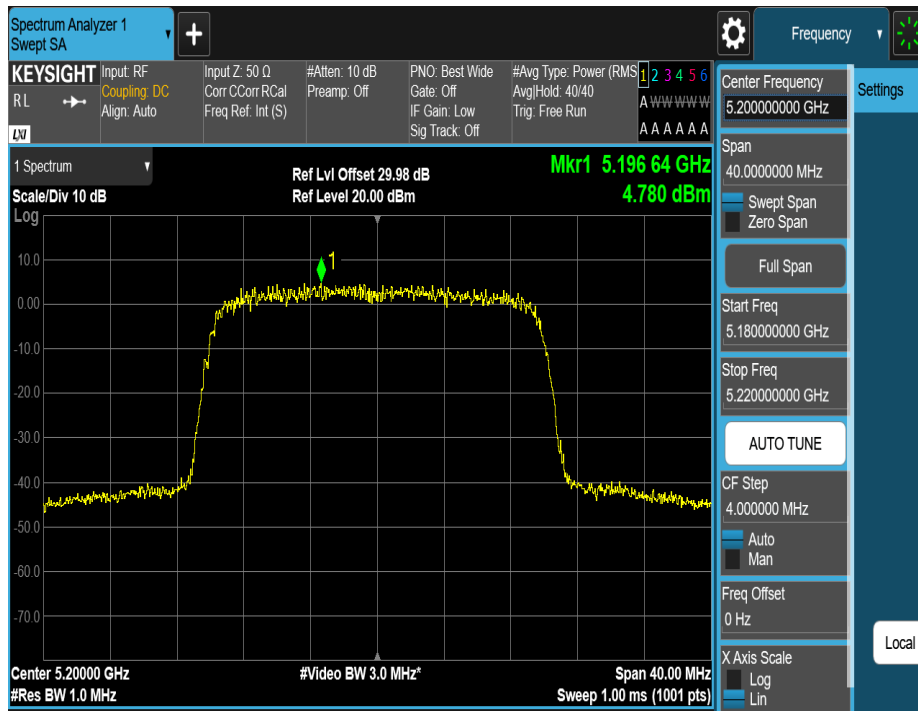

11AX20MIMO\_Ant1\_5240

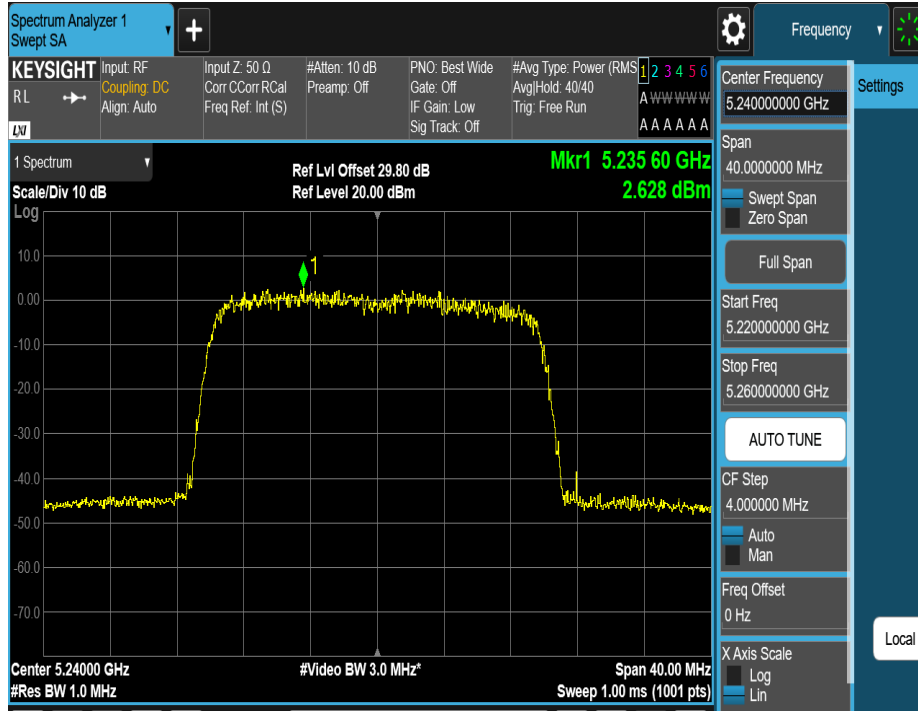

11AX20MIMO\_Ant2\_5240

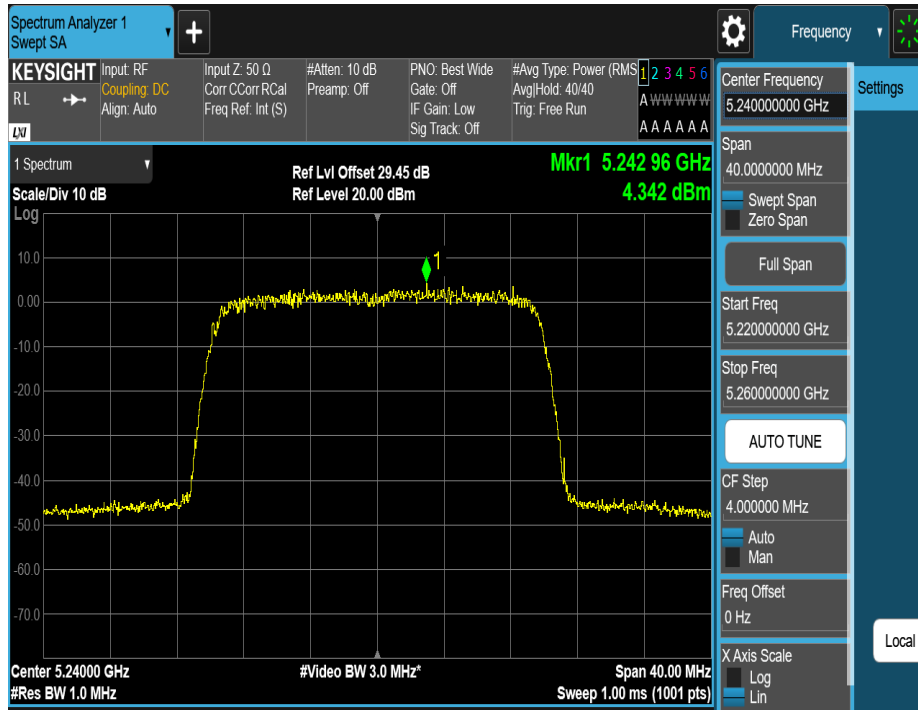



11AX20MIMO\_Ant1\_5260

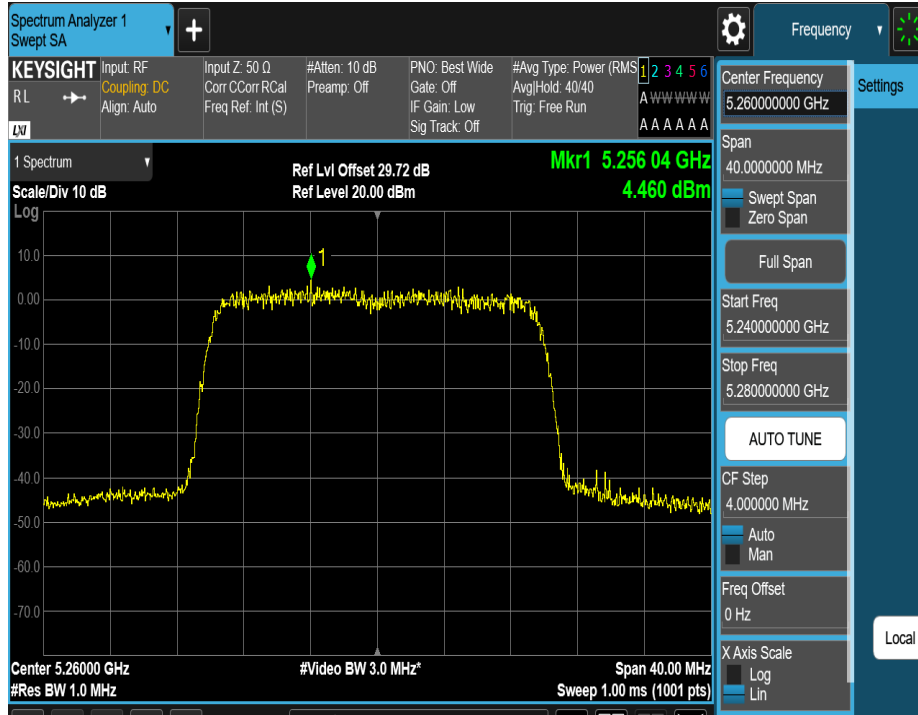

11AX20MIMO\_Ant2\_5260

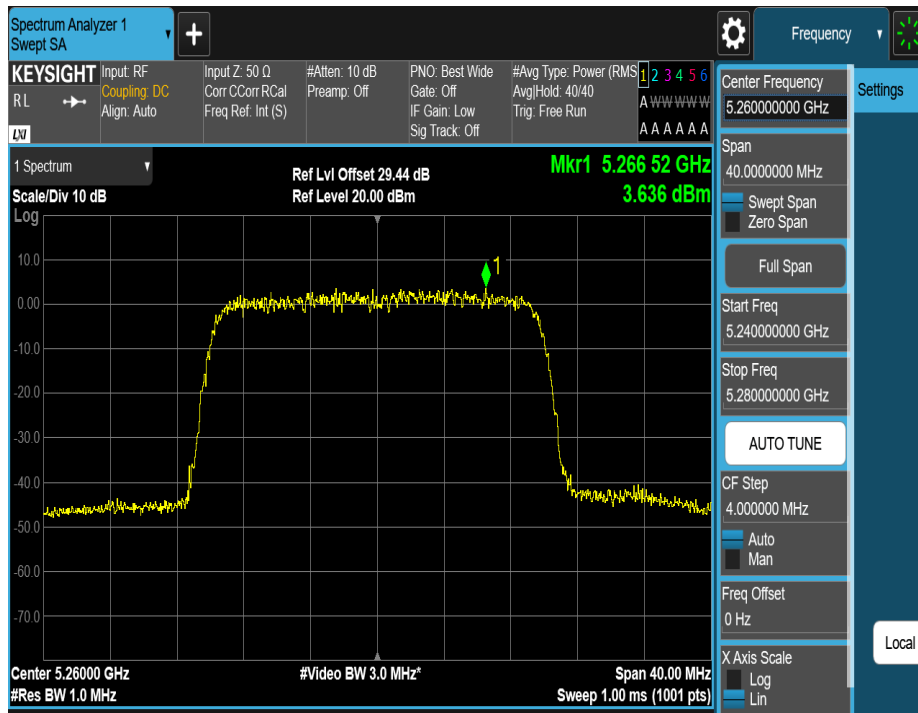

11AX20MIMO\_Ant1\_5280

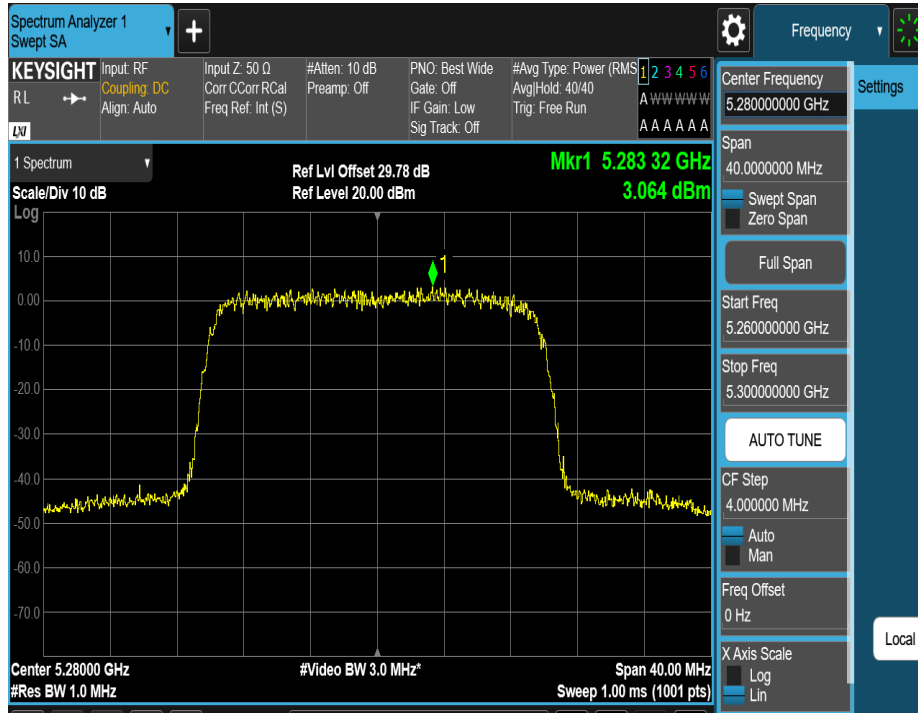

11AX20MIMO\_Ant2\_5280

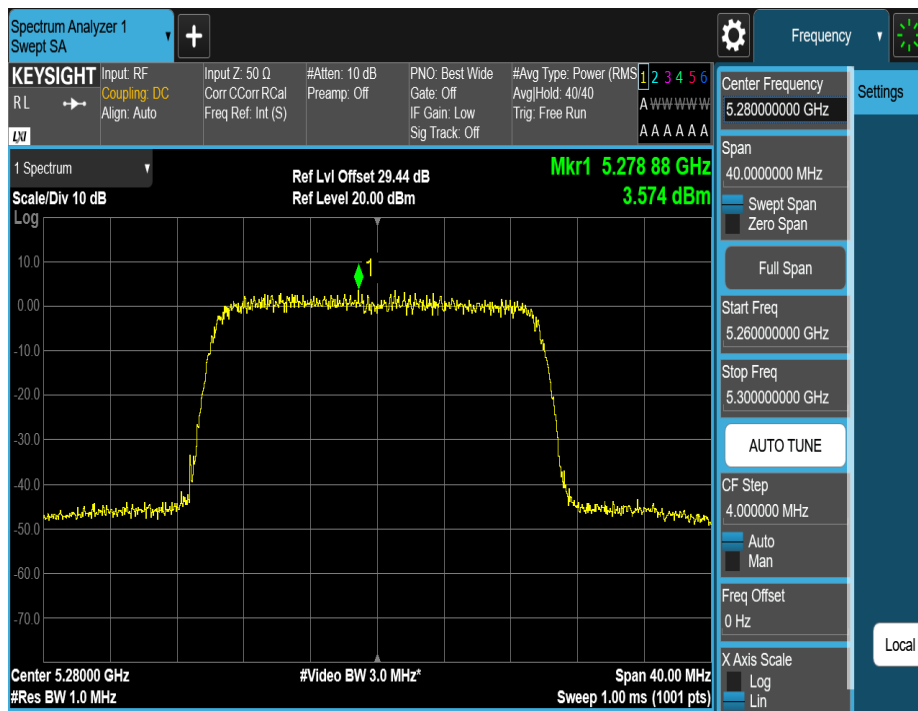

11AX20MIMO\_Ant1\_5320

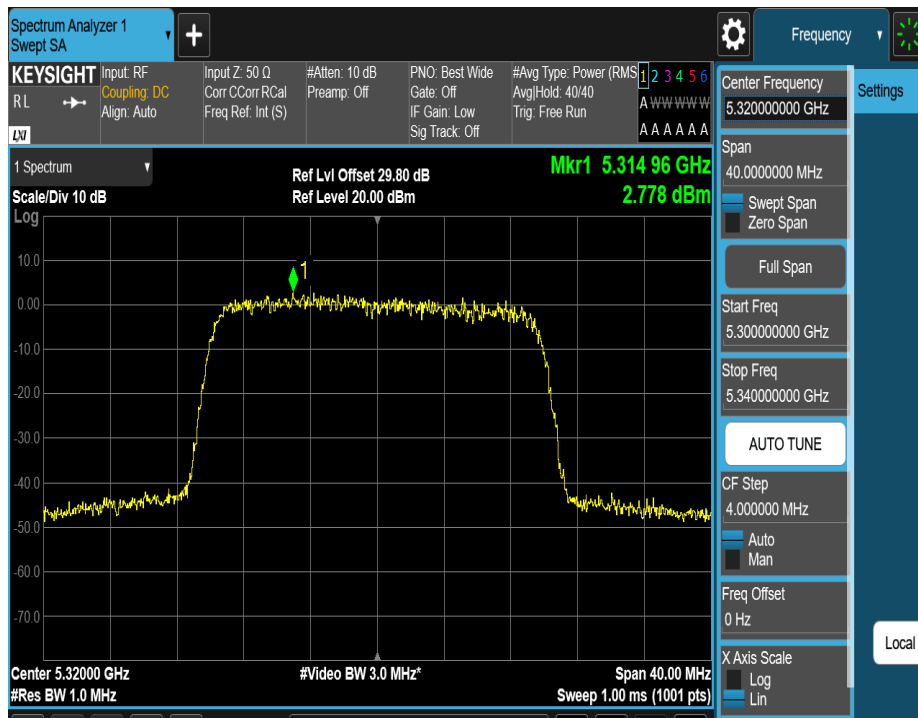

11AX20MIMO\_Ant2\_5320

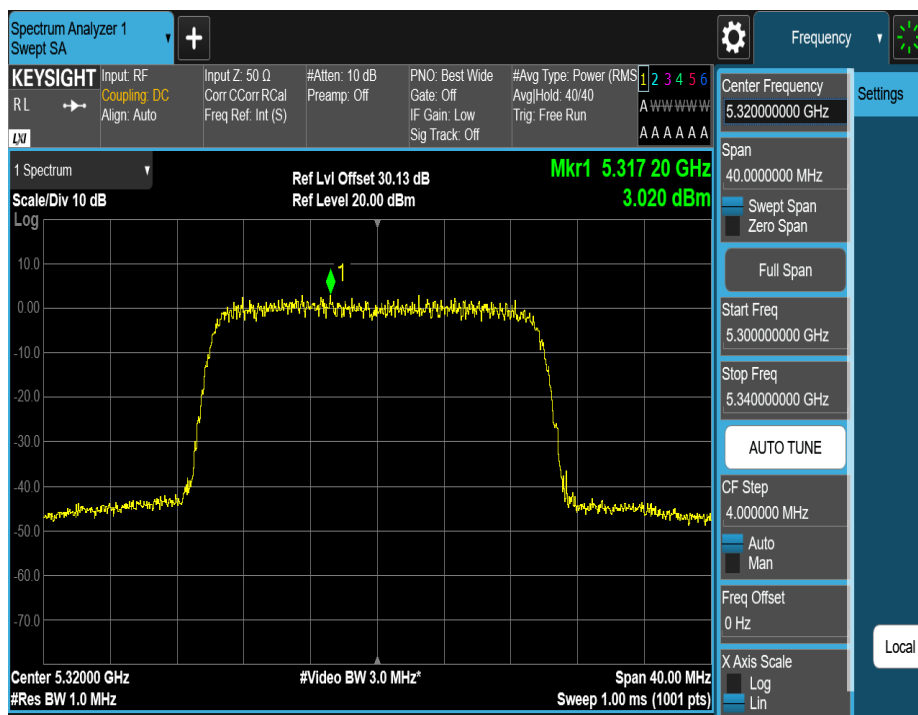

11AX20MIMO\_Ant1\_5500

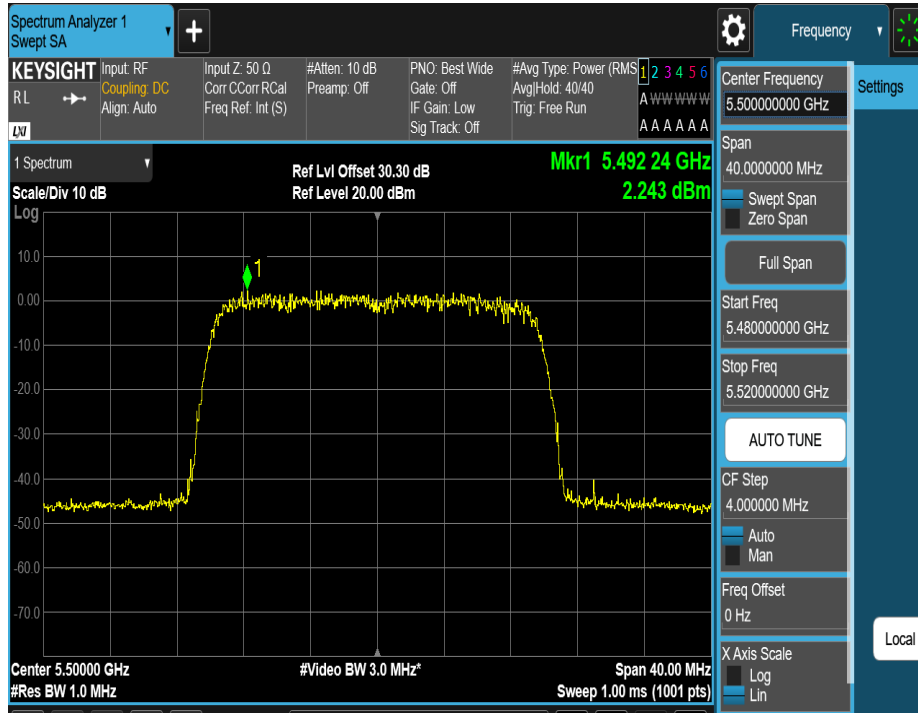

11AX20MIMO\_Ant2\_5500

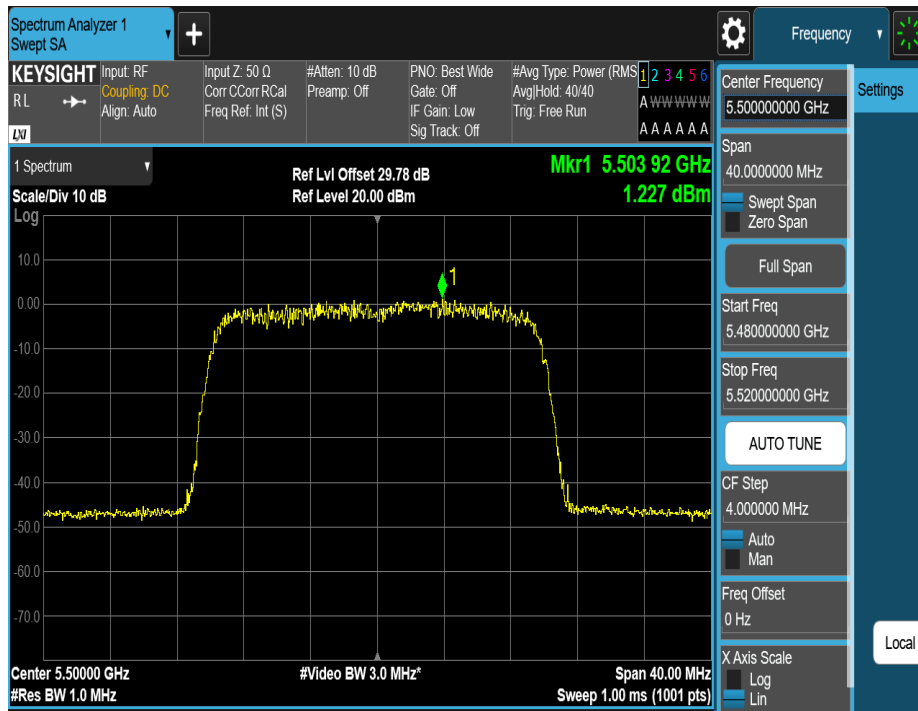

11AX20MIMO\_Ant1\_5580

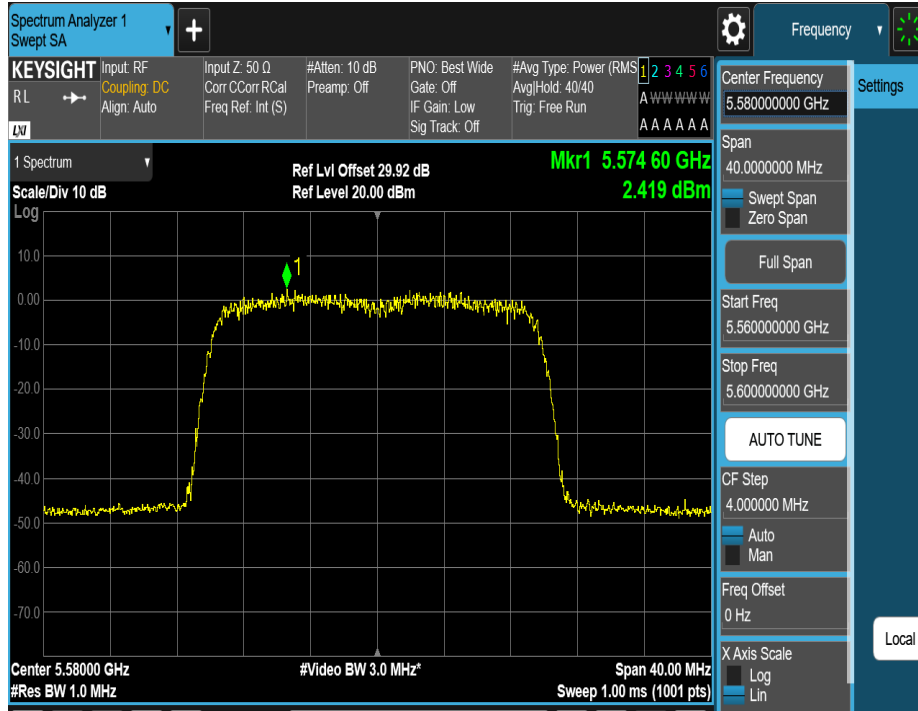

11AX20MIMO\_Ant2\_5580

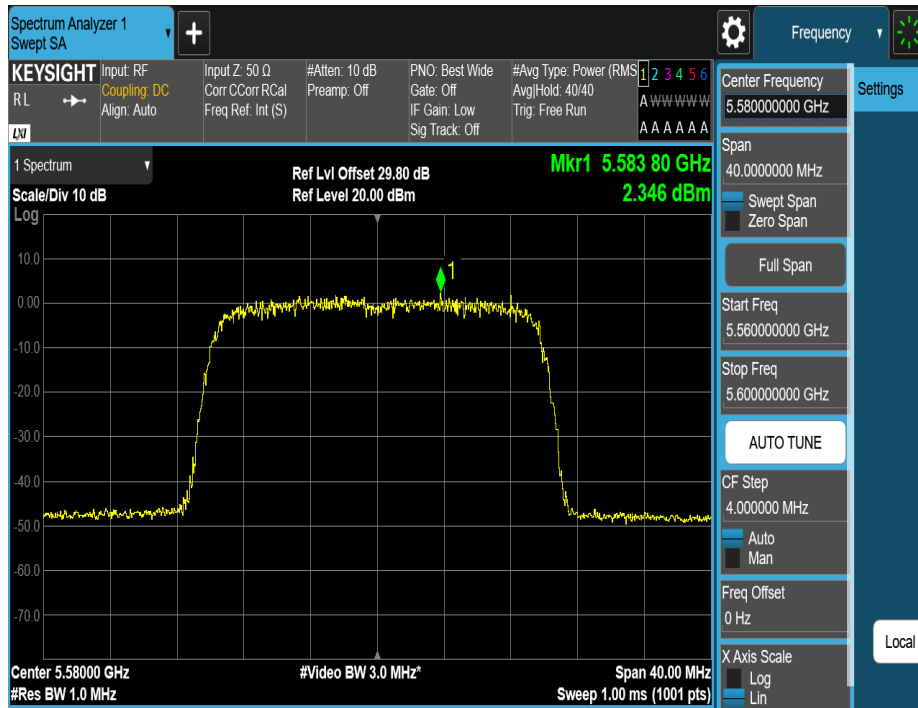

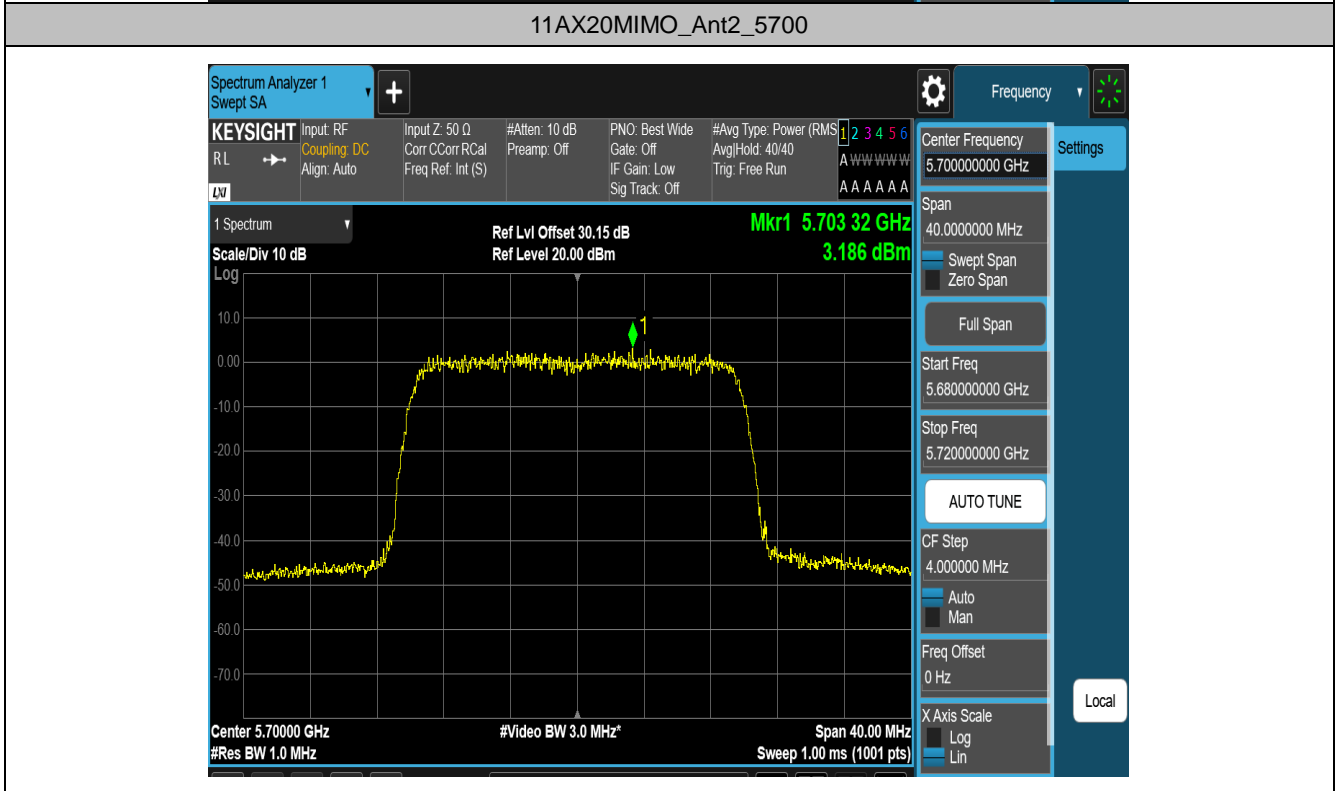
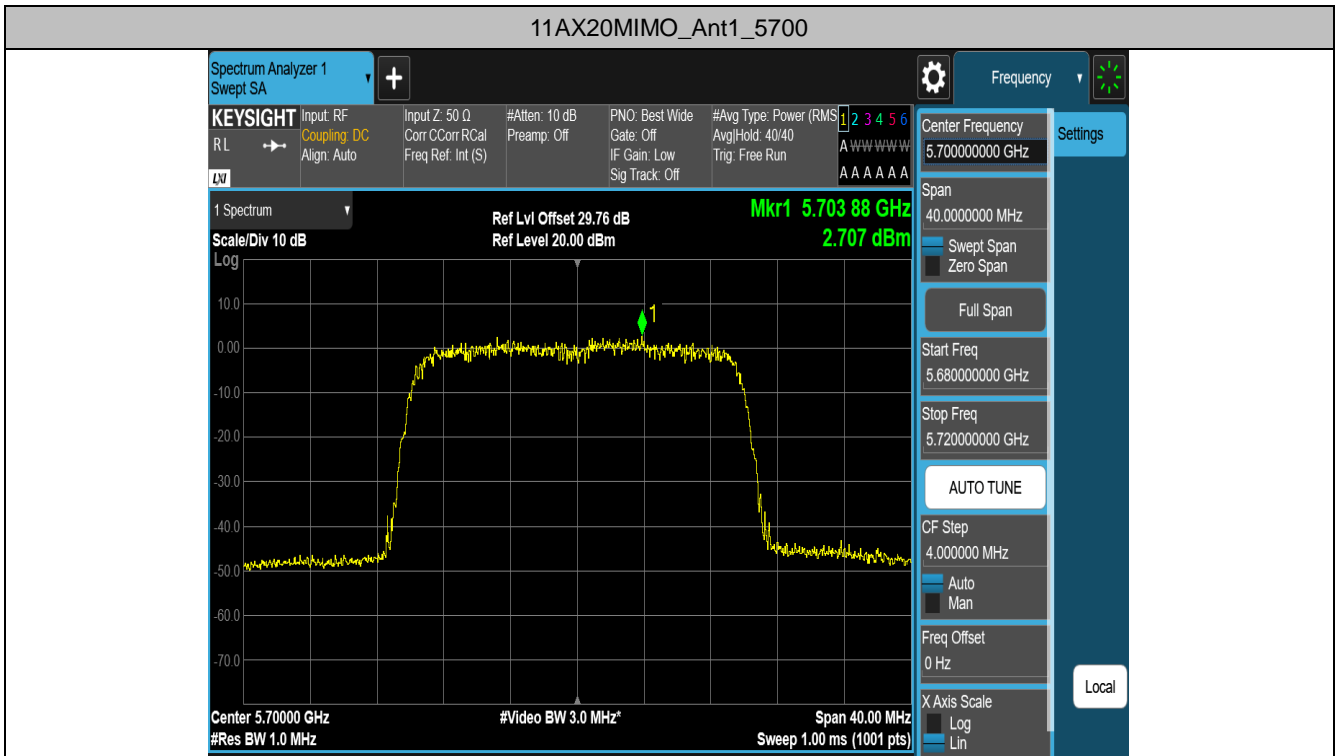

11AX20MIMO\_Ant1\_5745

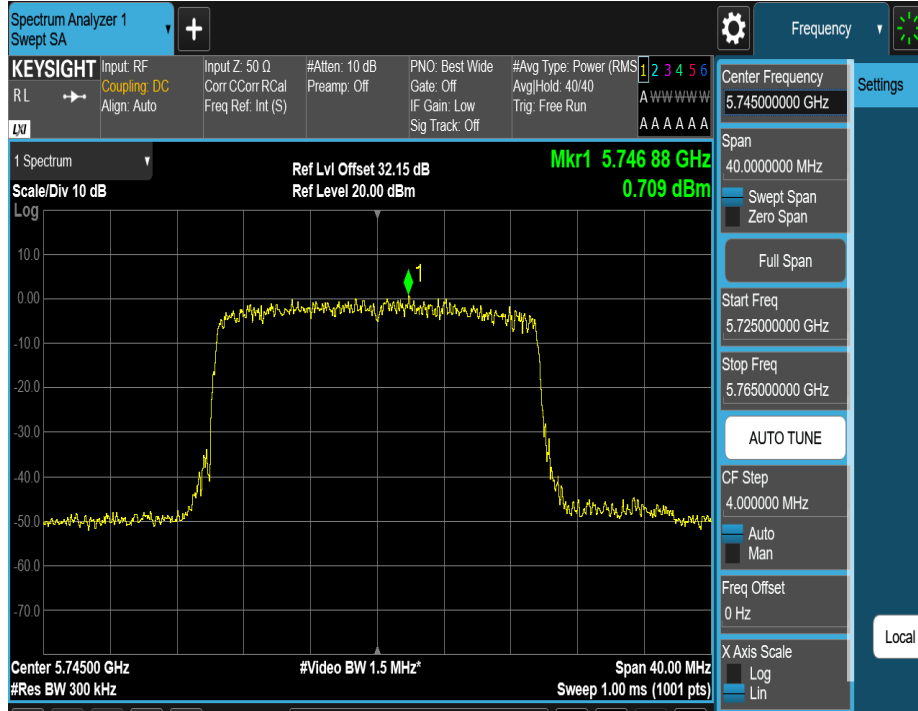

11AX20MIMO\_Ant2\_5745

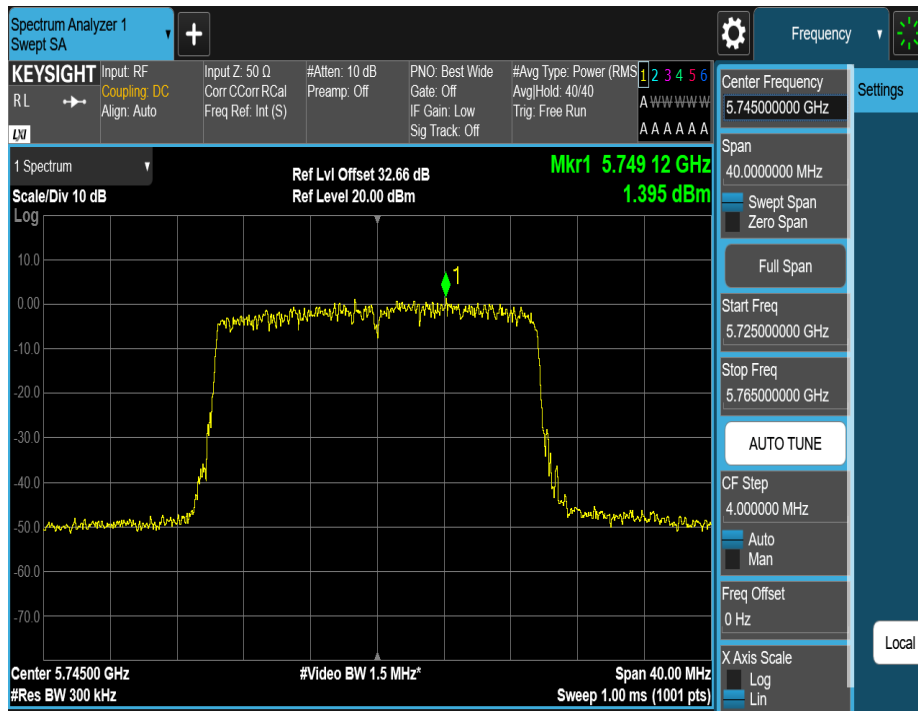

11AX20MIMO\_Ant1\_5785

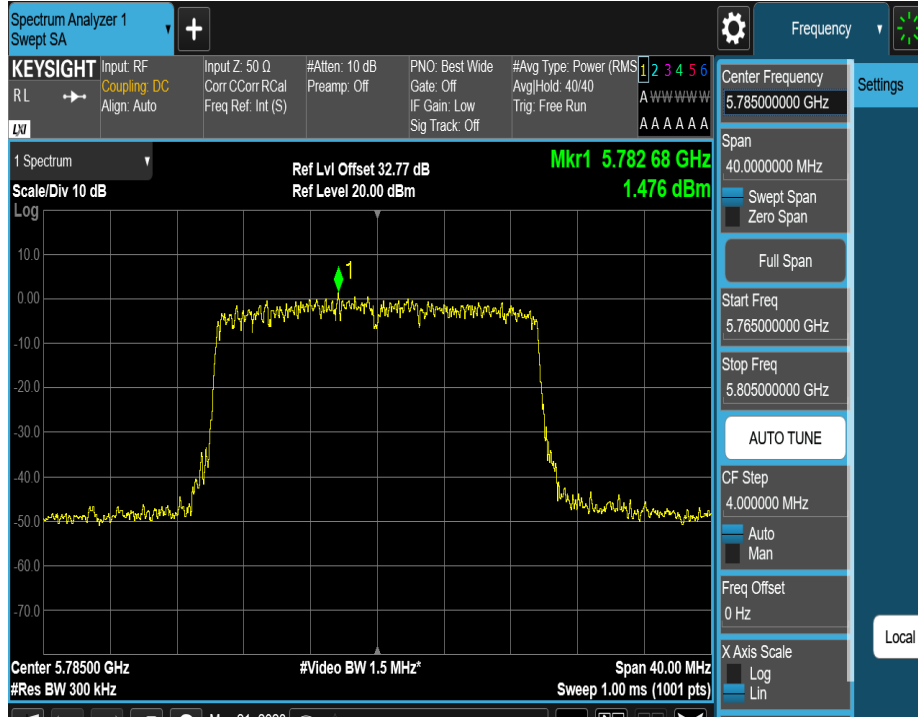

11AX20MIMO\_Ant2\_5785

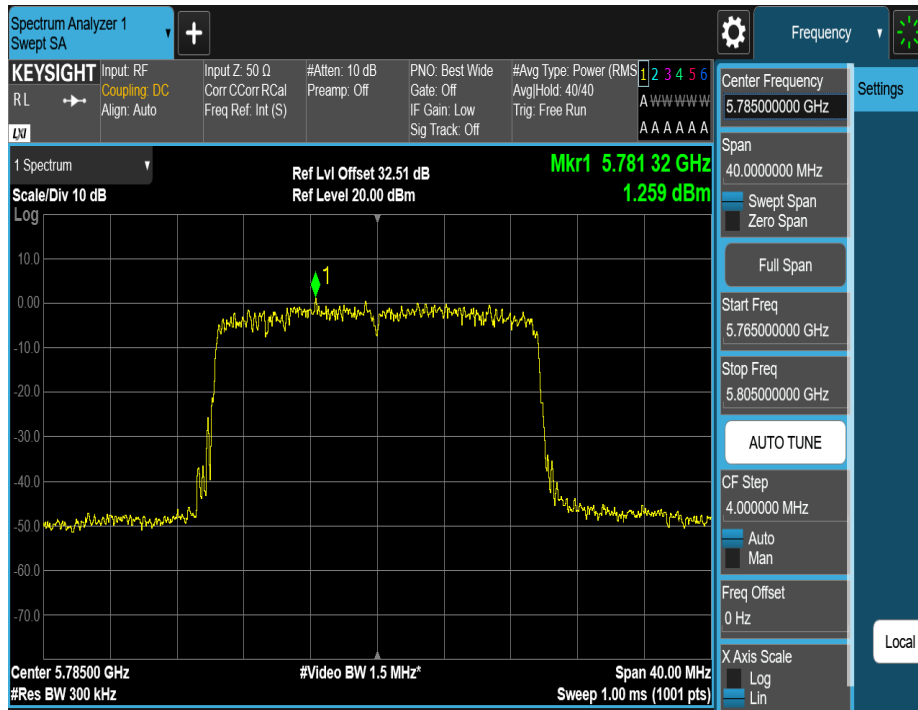



11AX20MIMO\_Ant1\_5825

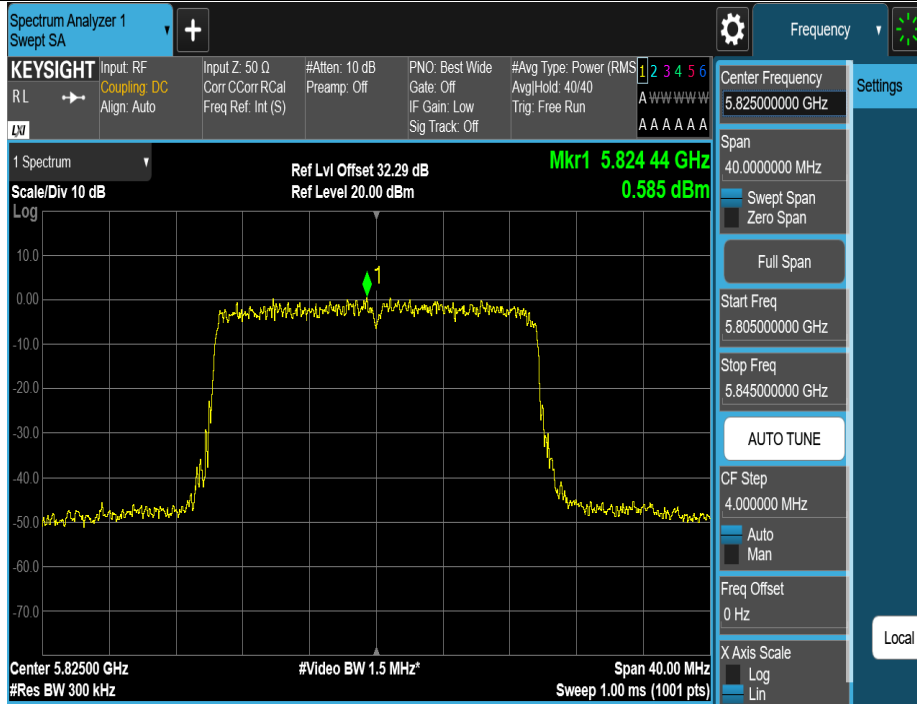

11AX20MIMO\_Ant2\_5825

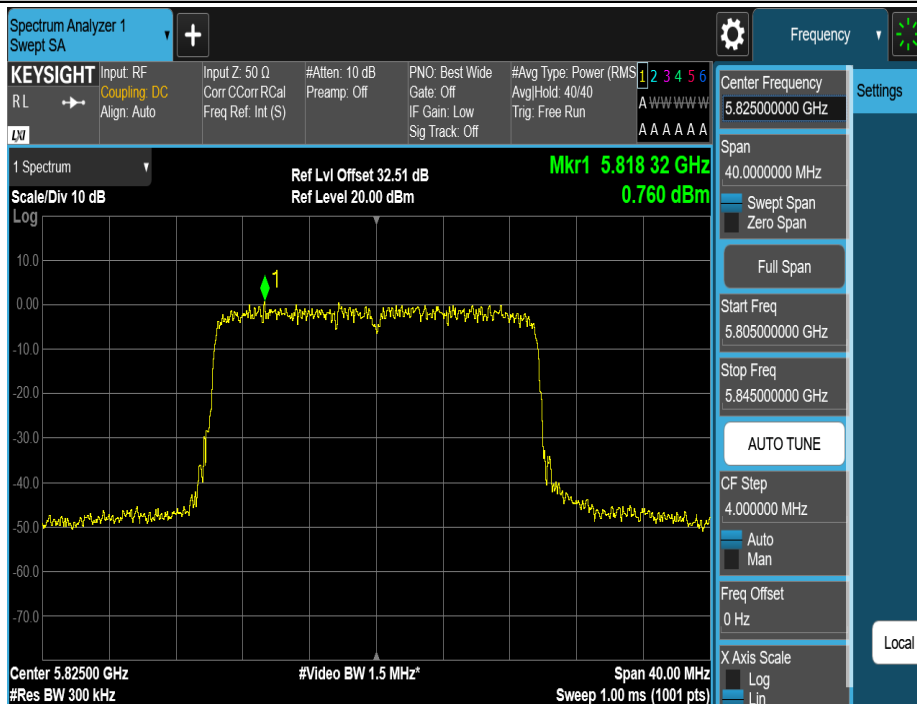

11AX40MIMO\_Ant1\_5190

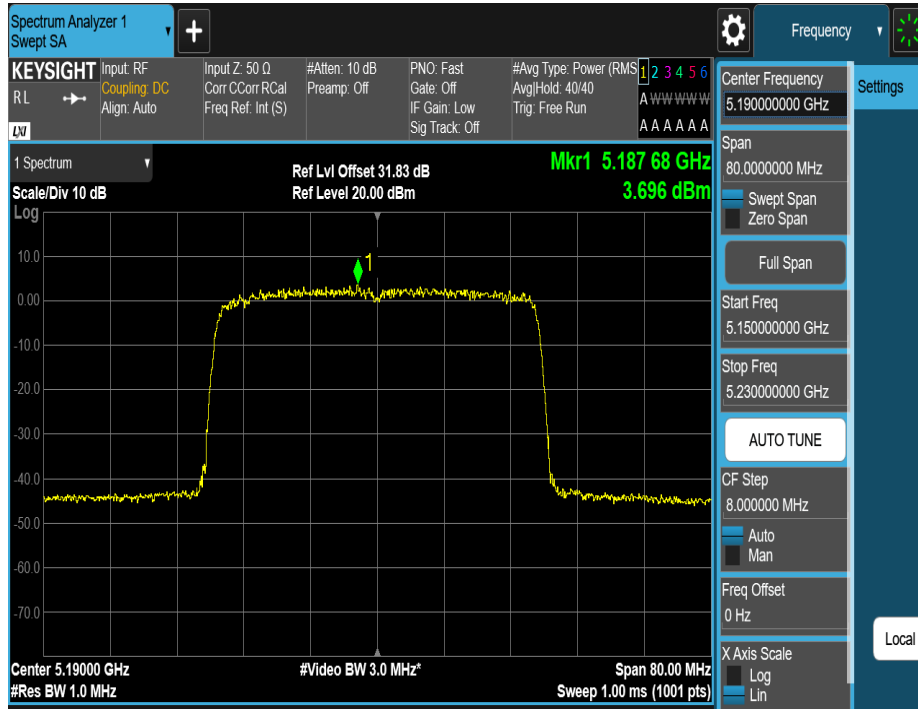

11AX40MIMO\_Ant2\_5190

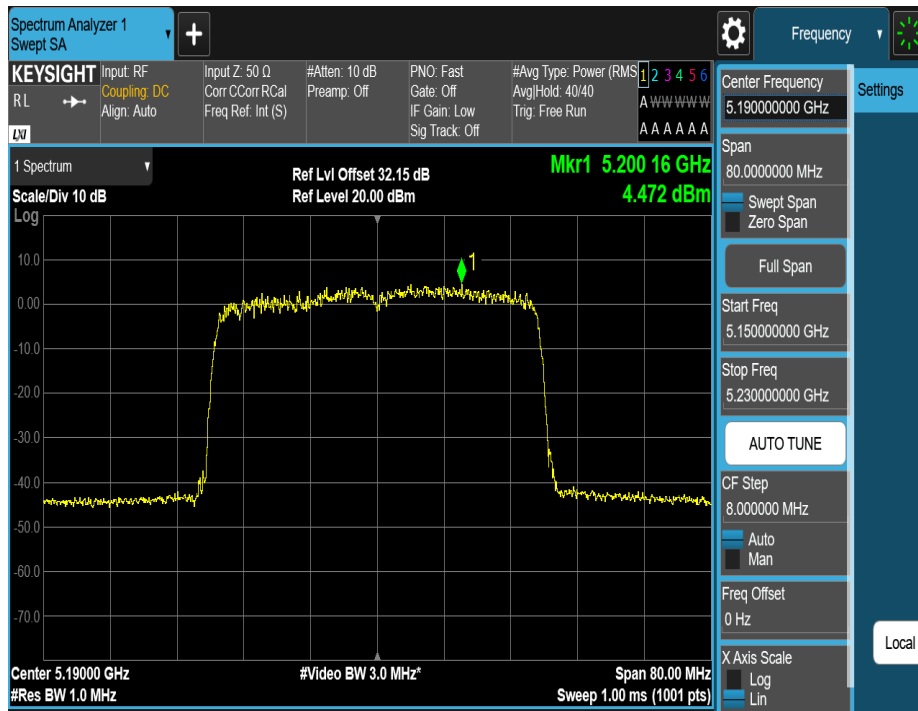

11AX40MIMO\_Ant1\_5230

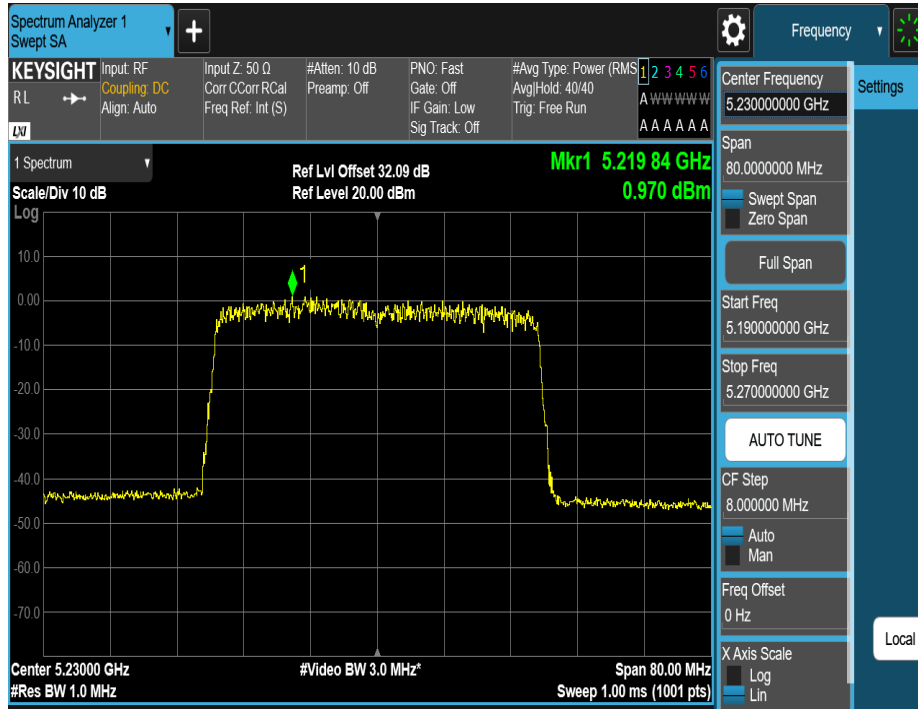

11AX40MIMO\_Ant2\_5230

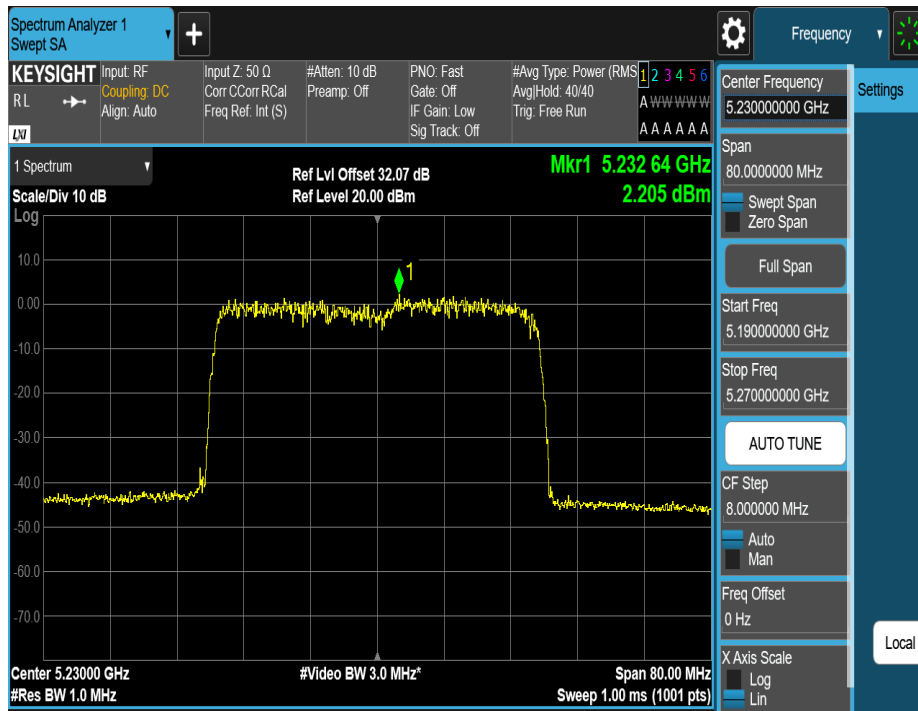

11AX40MIMO\_Ant1\_5270

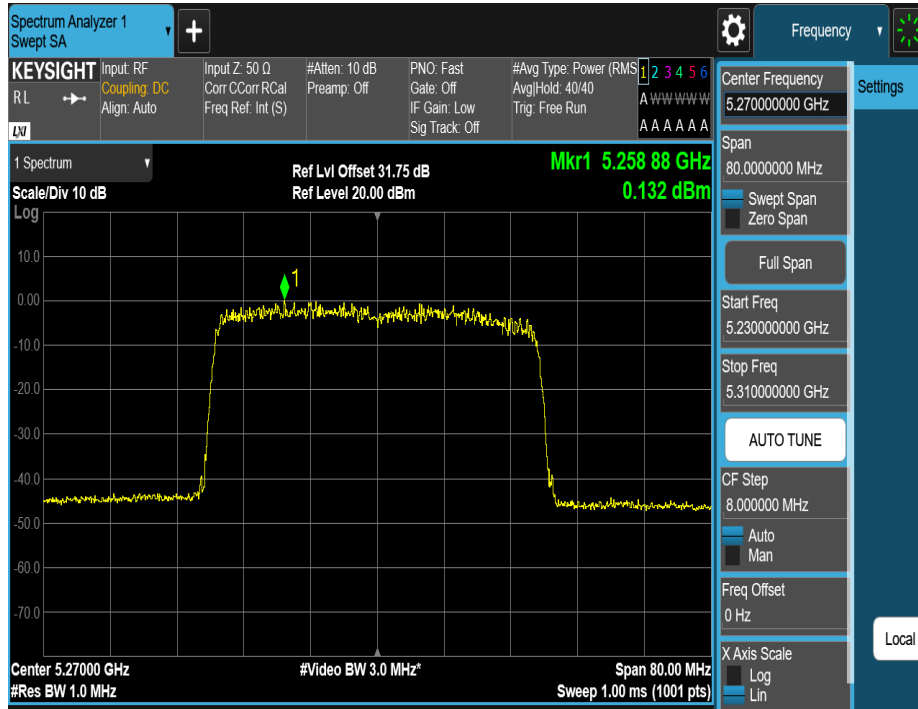

11AX40MIMO\_Ant2\_5270

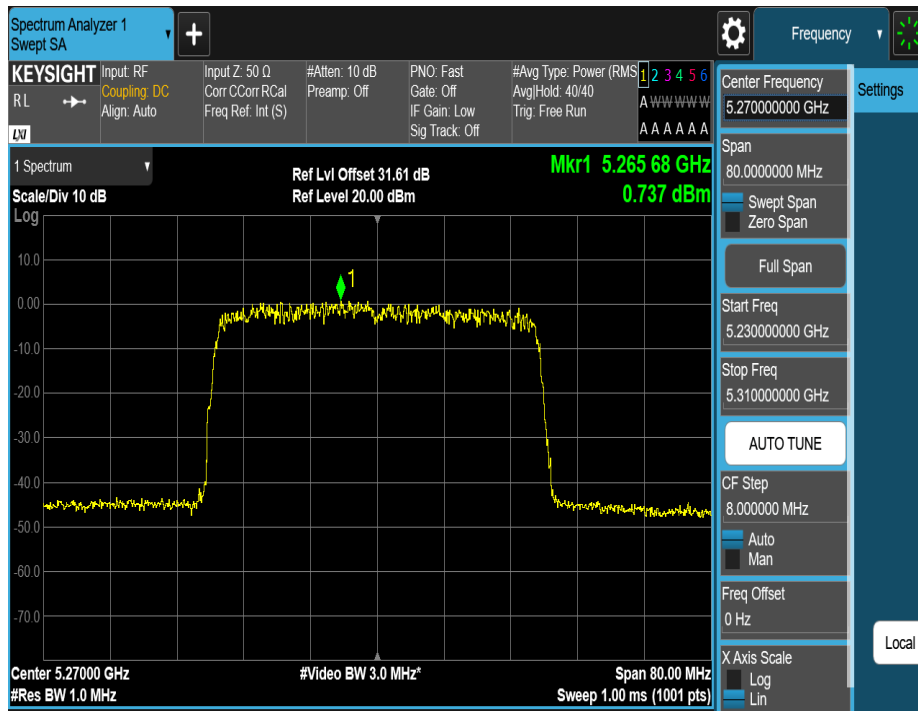

11AX40MIMO\_Ant1\_5310

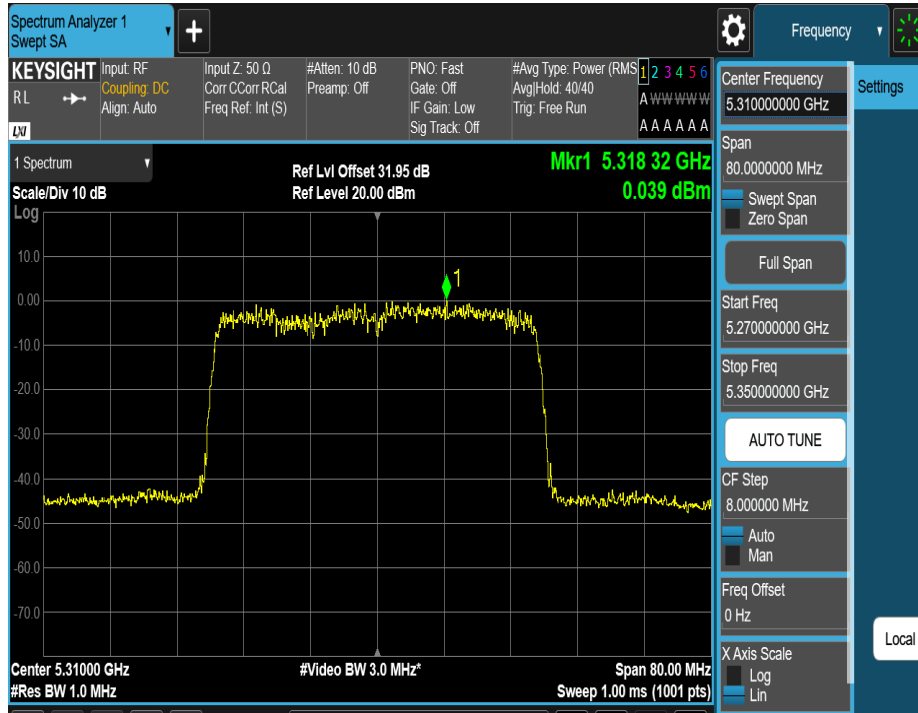

11AX40MIMO\_Ant2\_5310

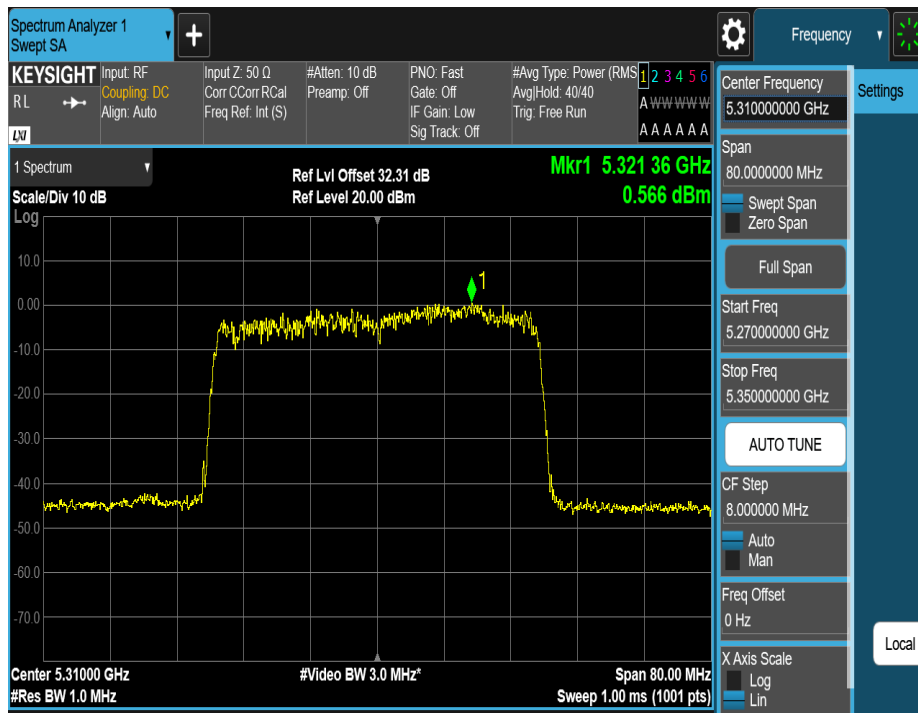

11AX40MIMO\_Ant1\_5510

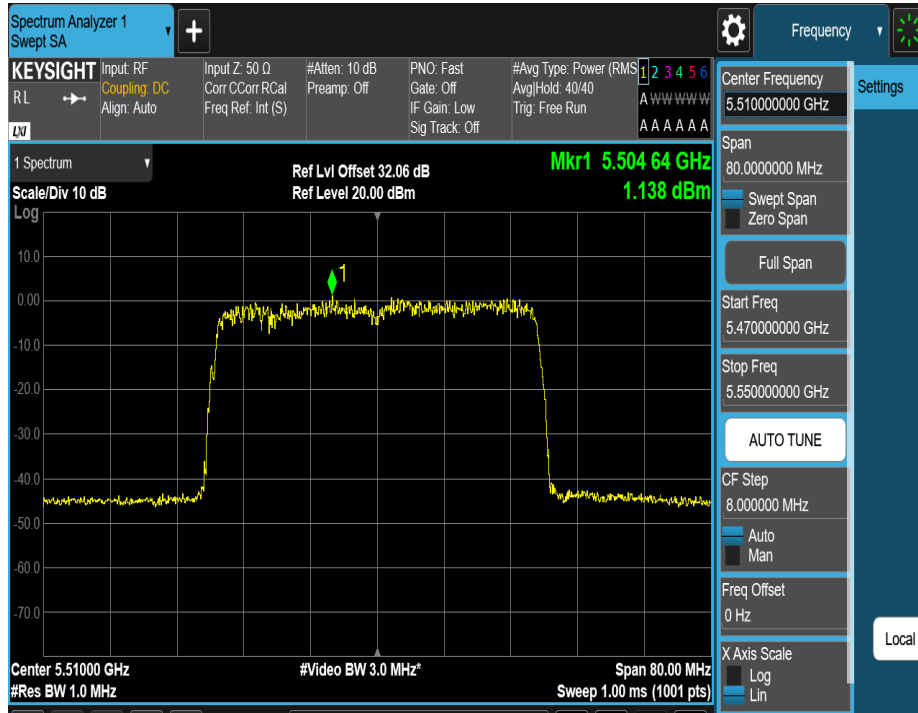

11AX40MIMO\_Ant2\_5510

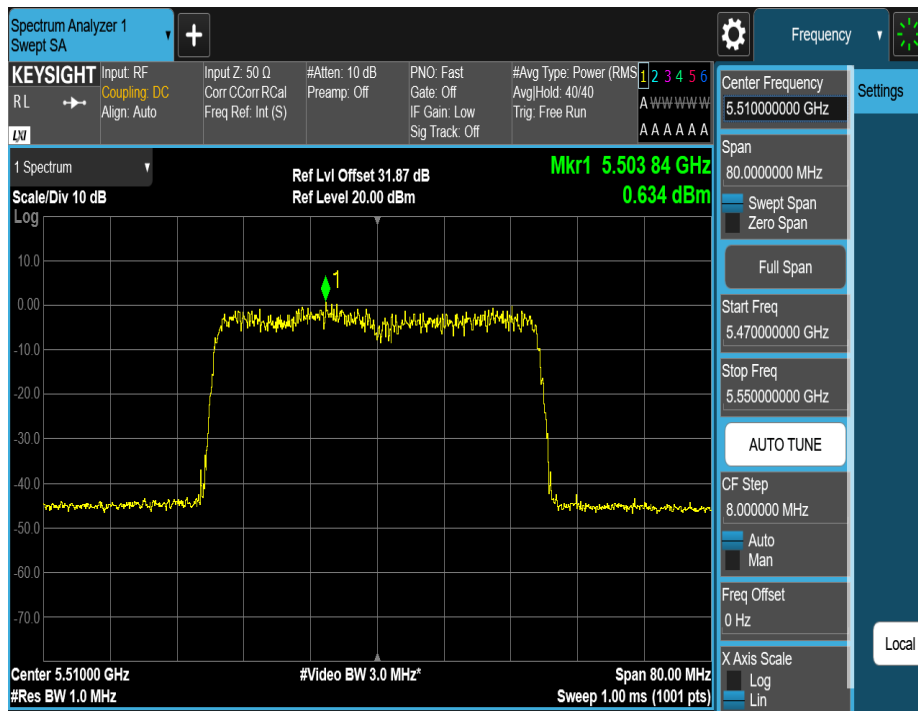

11AX40MIMO\_Ant1\_5550

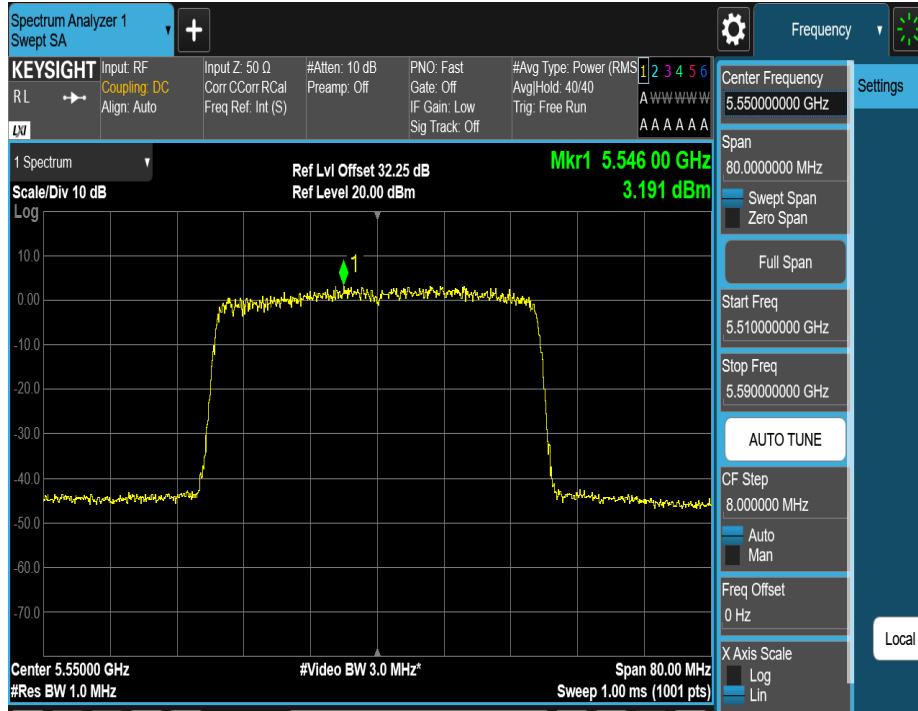

11AX40MIMO\_Ant2\_5550

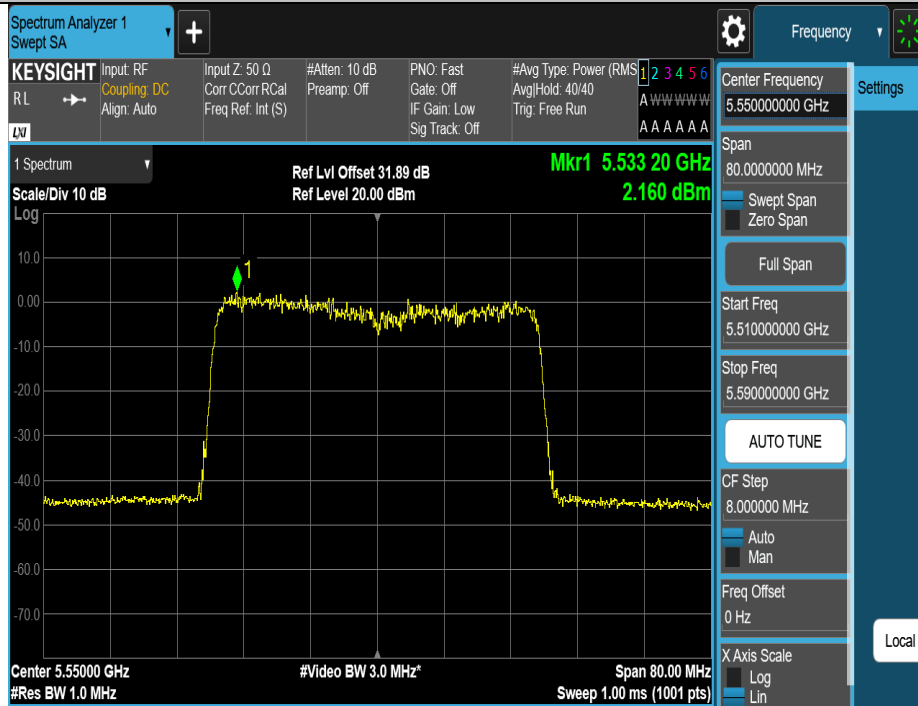

11AX40MIMO\_Ant1\_5670

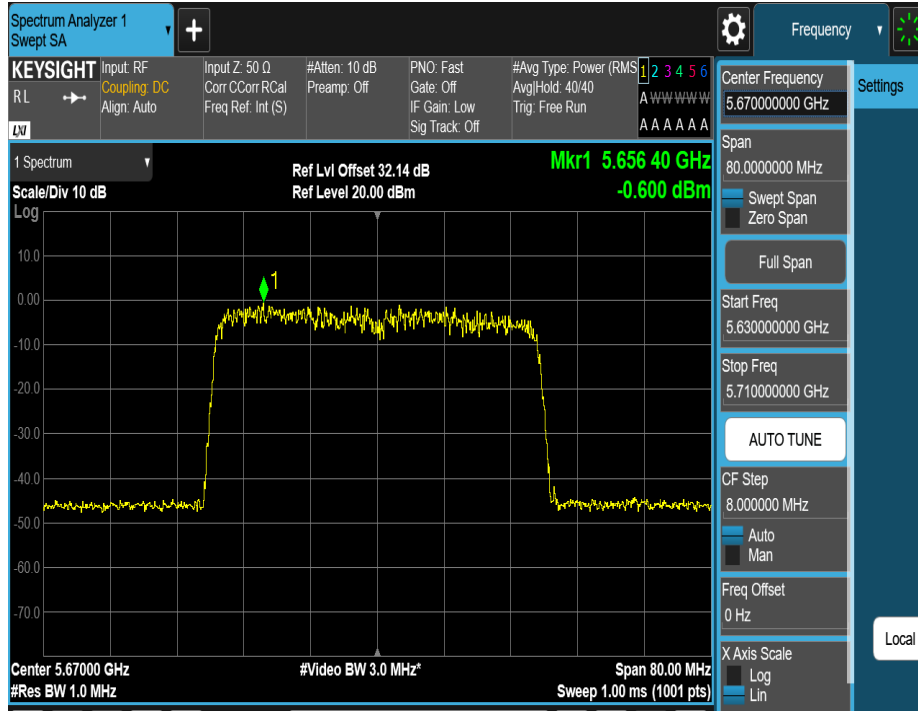

11AX40MIMO\_Ant2\_5670

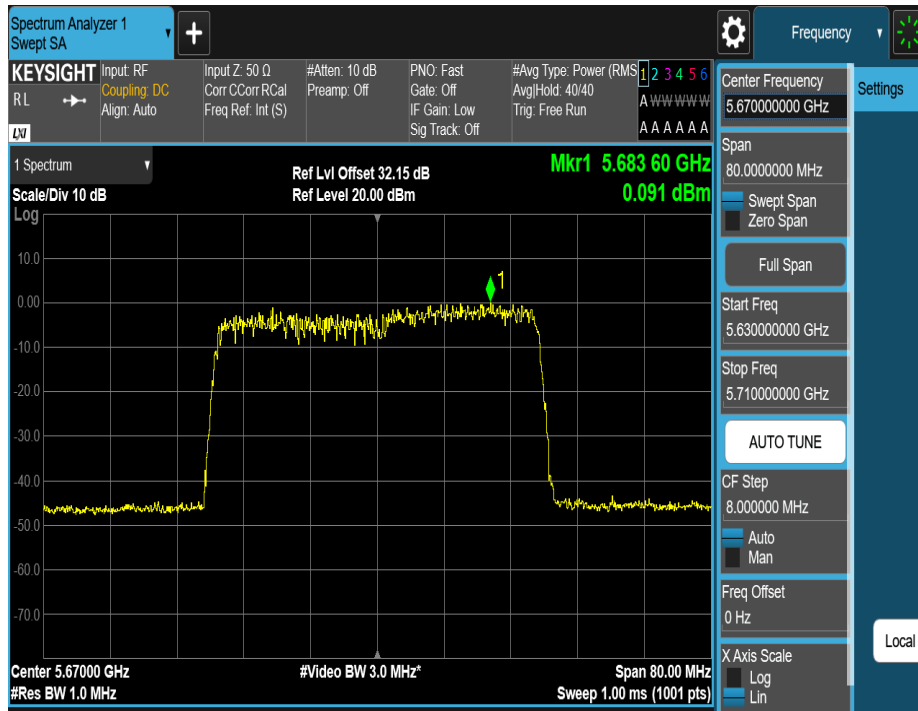



11AX40MIMO\_Ant1\_5755

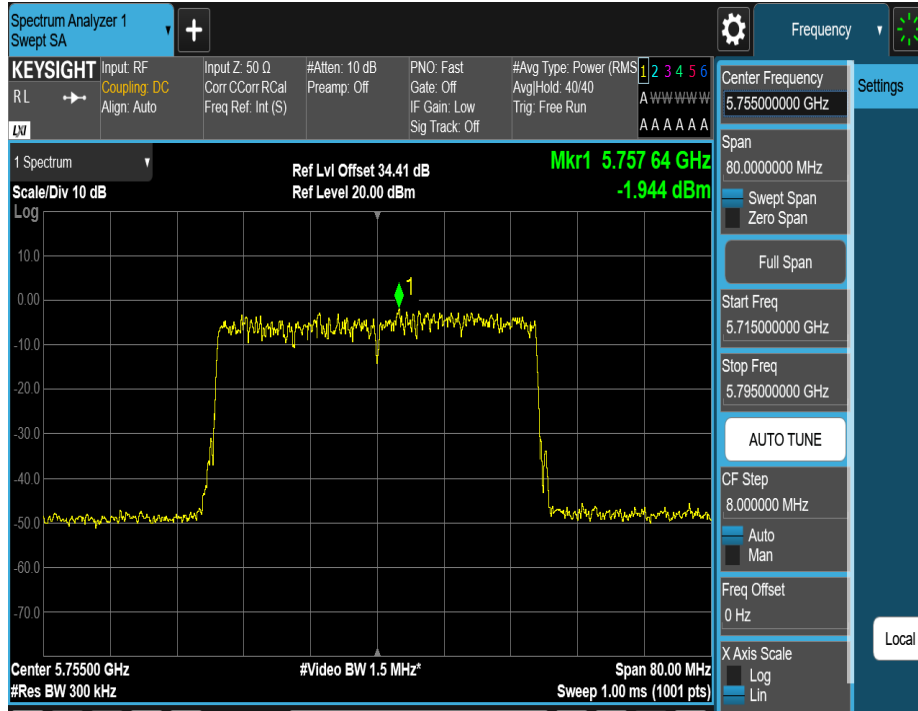

11AX40MIMO\_Ant2\_5755

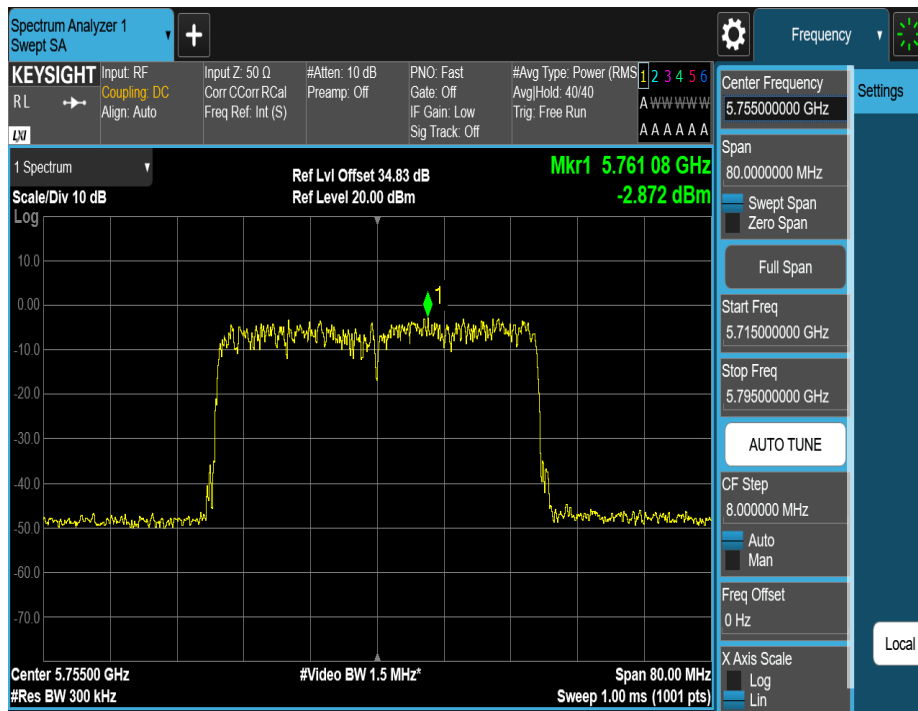

11AX40MIMO\_Ant1\_5795

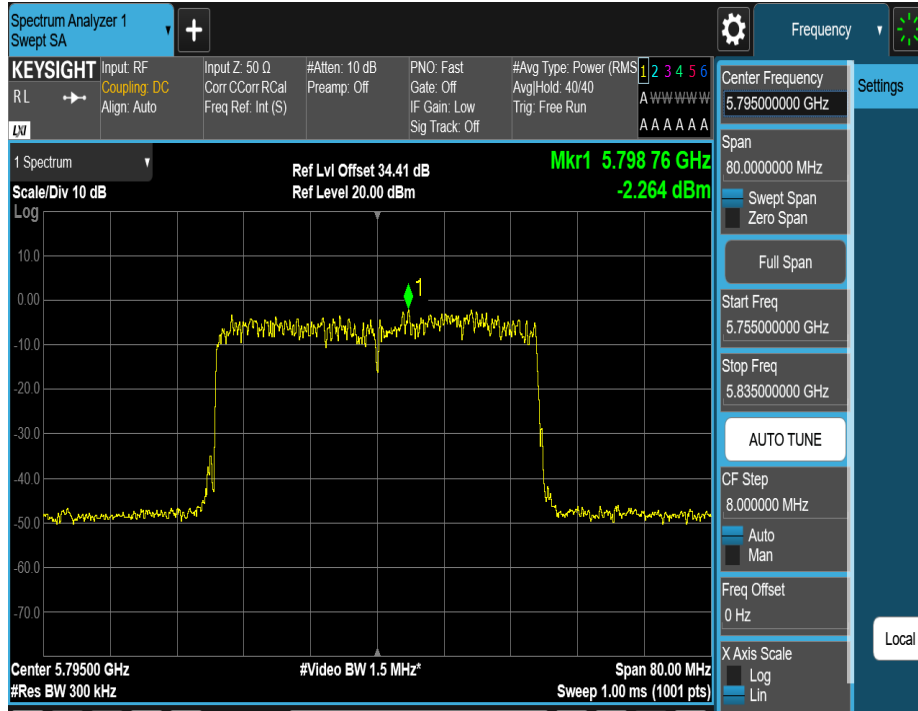

11AX40MIMO\_Ant2\_5795

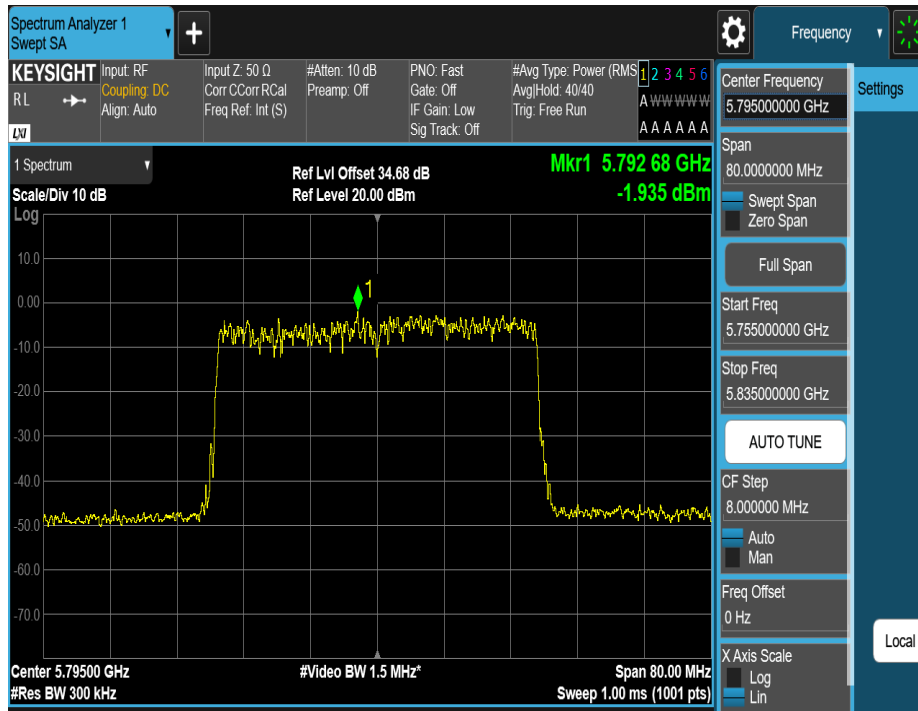

11AX80MIMO\_Ant1\_5210

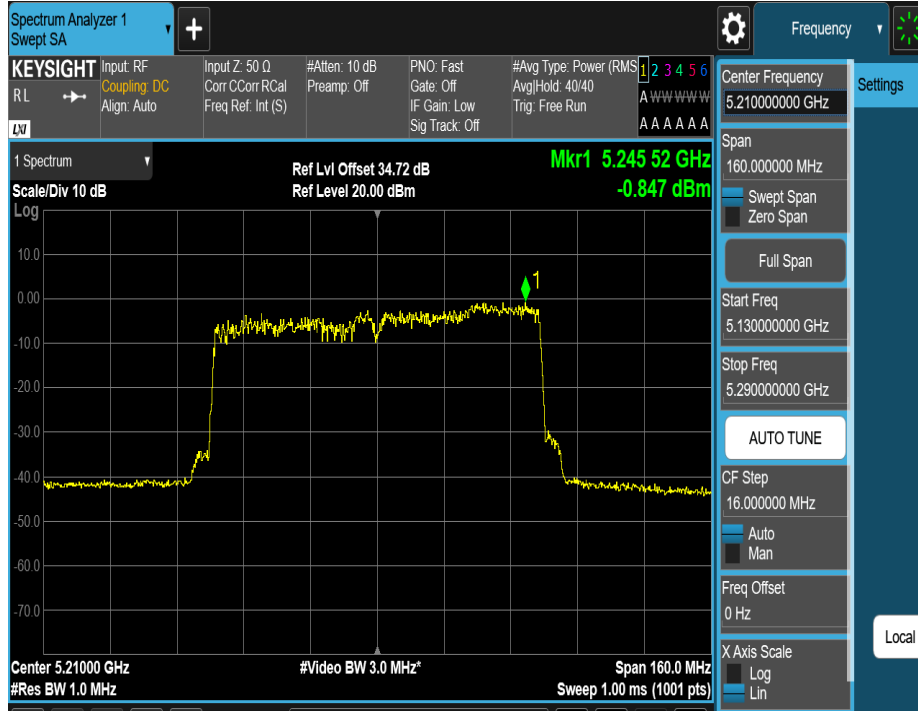

11AX80MIMO\_Ant2\_5210

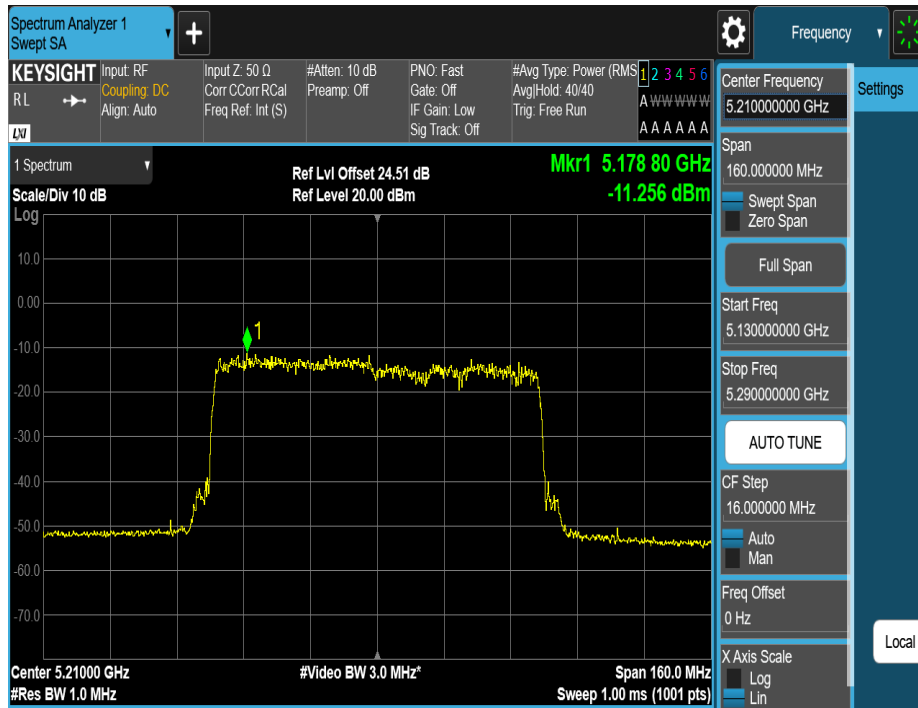

11AX80MIMO\_Ant1\_5290

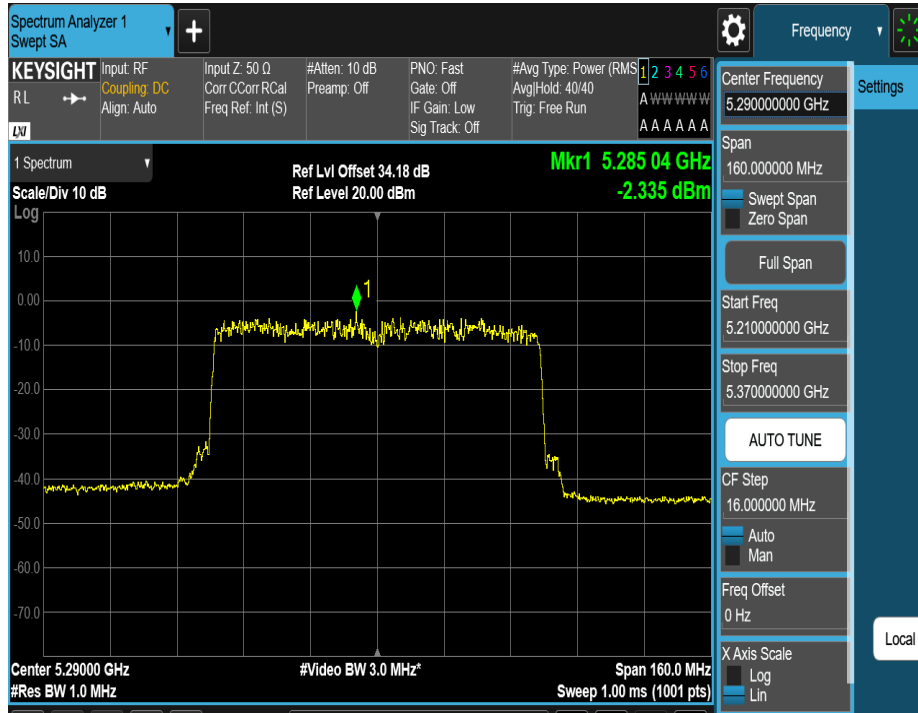

11AX80MIMO\_Ant2\_5290

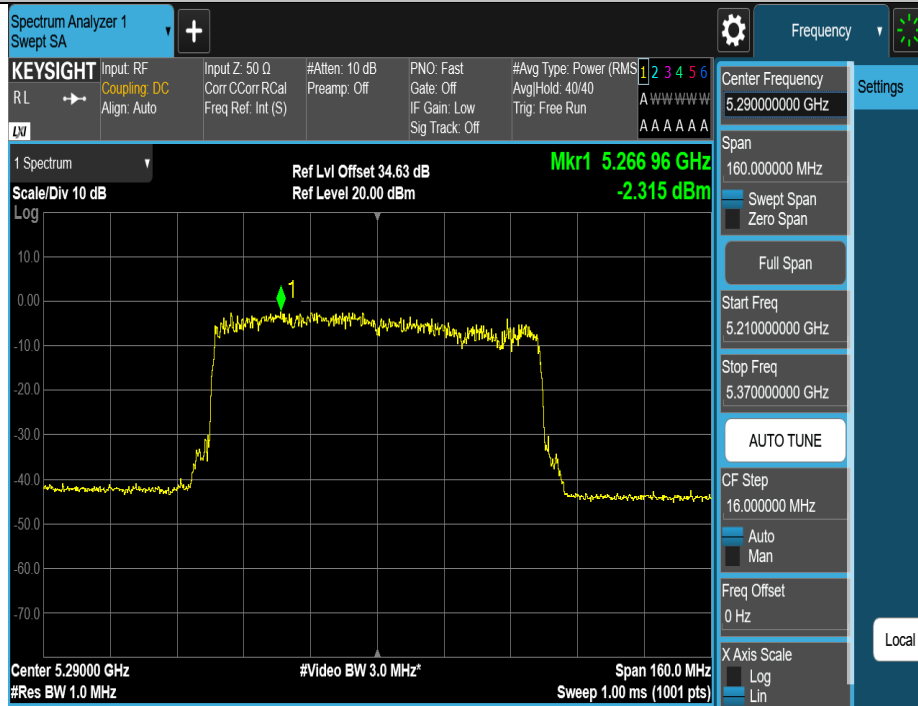

11AX80MIMO\_Ant1\_5530

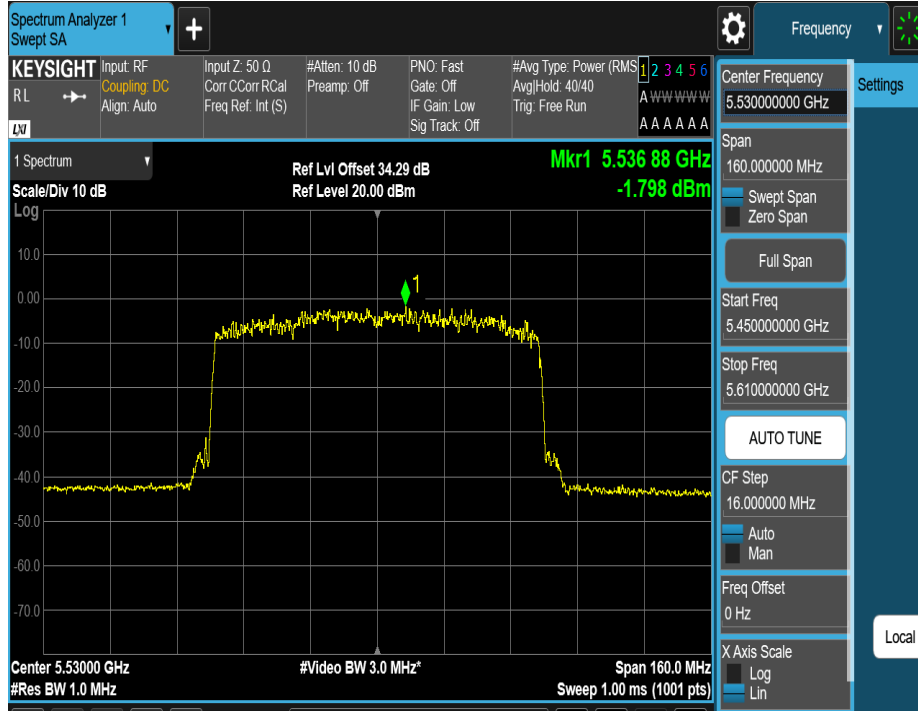

11AX80MIMO\_Ant2\_5530

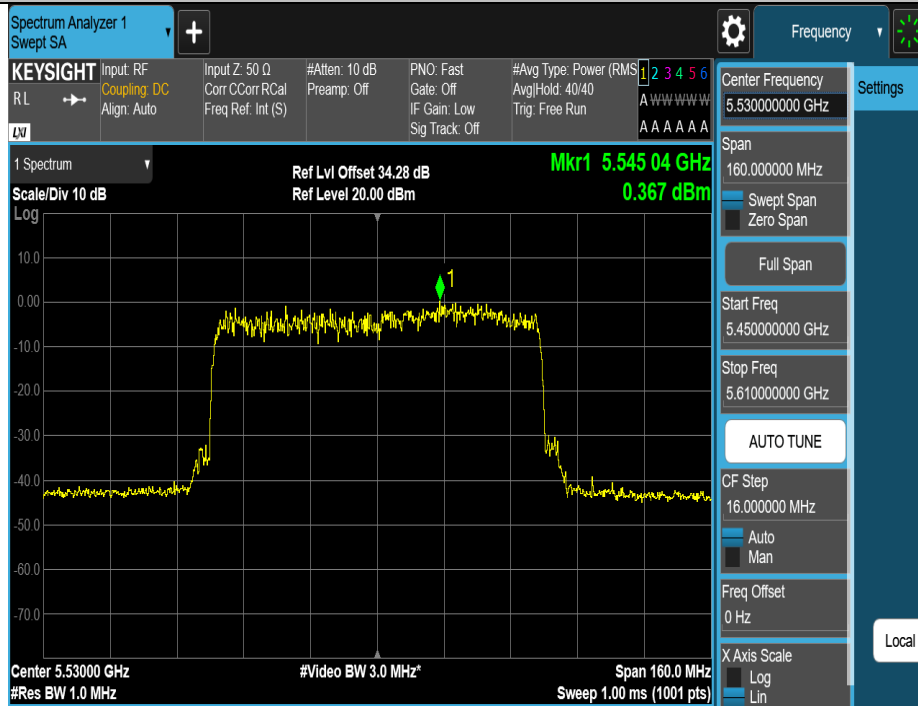

11AX80MIMO\_Ant1\_5610

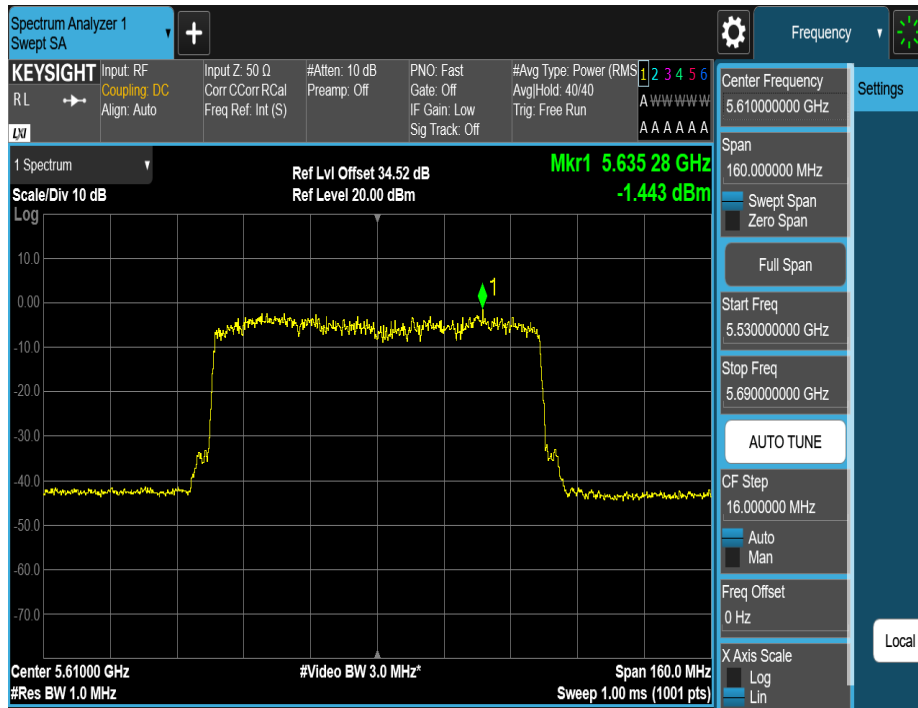

11AX80MIMO\_Ant2\_5610

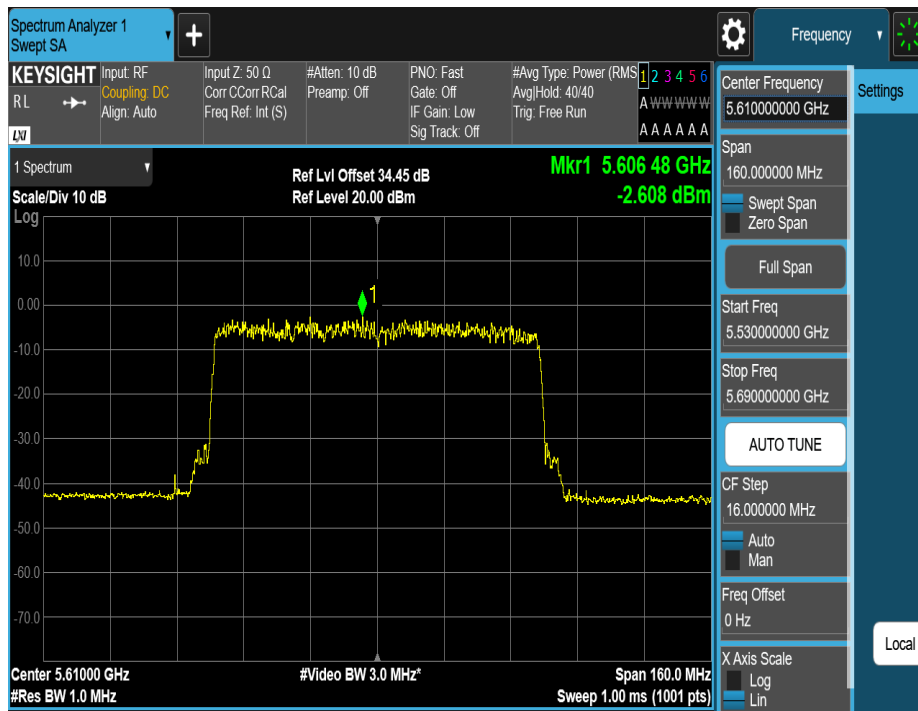

11AX80MIMO\_Ant1\_5775

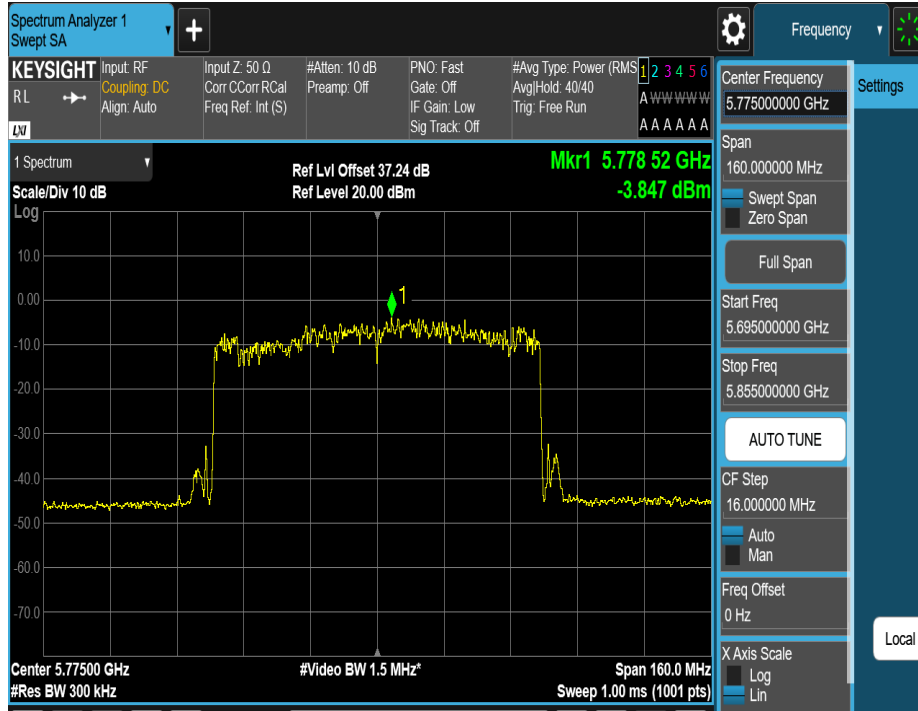

11AX80MIMO\_Ant2\_5775

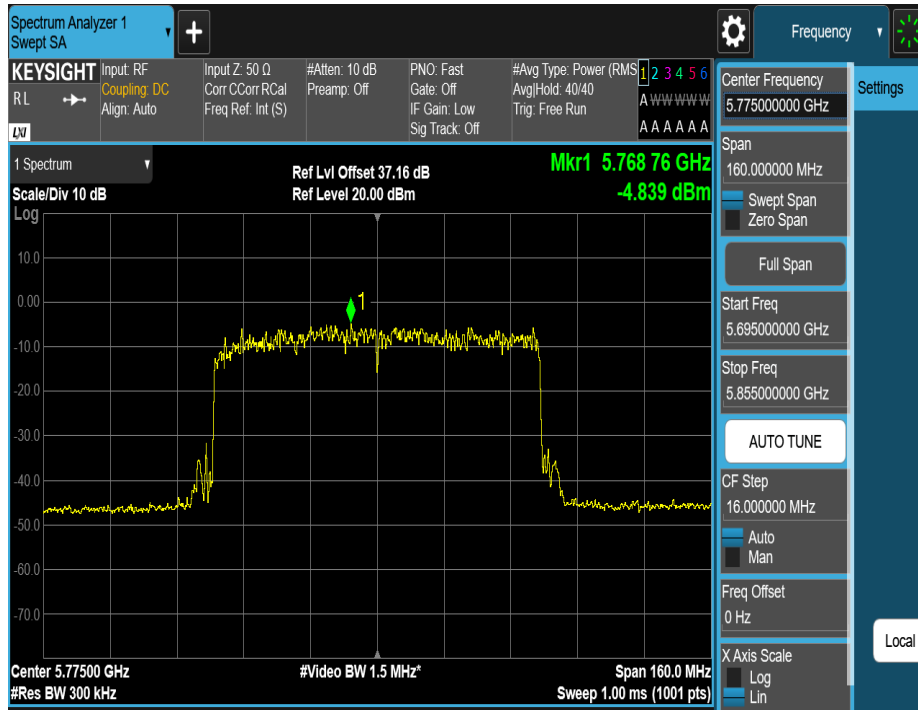

## 3.6 Dynamic Frequency Selection (DFS)

### 3.6.1 DFS Overview

A U-NII network will employ a DFS function to detect signals from radar systems and to avoid co-channel operation with these systems. This applies to the 5250-5350 MHz and/or 5470-5725 MHz bands.

Within the context of the operation of the DFS function, a U-NII device will operate in either Master Mode or Master Mode. U-NII devices operating in Master Mode can only operate in a network controlled by a UNII device operating in Master Mode.

### 3.6.2 Working modes and required test items

**Table 1: Applicability of DFS Requirements Prior to Use of a Channel**

Requirement	Operational Mode		
	Master	Client Without Radar Detection	Client With Radar Detection
<i>Non-Occupancy Period</i>	Yes	Not required	Yes
<i>DFS Detection Threshold</i>	Yes	Not required	Yes
<i>Channel Availability Check Time</i>	Yes	Not required	Not required
<i>U-NII Detection Bandwidth</i>	Yes	Not required	Yes



**Table 2: Applicability of DFS requirements during normal operation**

Requirement	Operational Mode	
	Master Device or Client with Radar Detection	Client Without Radar Detection
<i>DFS Detection Threshold</i>	Yes	Not required
<i>Channel Closing Transmission Time</i>	Yes	Yes
<i>Channel Move Time</i>	Yes	Yes
<i>U-NII Detection Bandwidth</i>	Yes	Not required

Additional requirements for devices with multiple bandwidth modes	Master Device or Client with Radar Detection	Client Without Radar Detection
<i>U-NII Detection Bandwidth and Statistical Performance Check</i>	All BW modes must be tested	Not required
<i>Channel Move Time and Channel Closing Transmission Time</i>	Test using widest BW mode available	Test using the widest BW mode available for the link
<i>All other tests</i>	Any single BW mode	Not required
<b>Note:</b> Frequencies selected for statistical performance check (Section 7.8.4) should include several frequencies within the radar detection bandwidth and frequencies near the edge of the radar detection bandwidth. For 802.11 devices it is suggested to select frequencies in each of the bonded 20 MHz channels and the channel center frequency.		

### 3.6.3 Test limits and radar signal parameters

**Table 3: DFS Detection Thresholds for Master Devices and Client Devices with Radar Detection**

Maximum Transmit Power	Value (See Notes 1, 2, and 3)
EIRP $\geq$ 200 milliwatt	-64 dBm
EIRP < 200 milliwatt and power spectral density < 10 dBm/MHz	-62 dBm
EIRP < 200 milliwatt that do not meet the power spectral density requirement	-64 dBm
<p><b>Note 1:</b> This is the level at the input of the receiver assuming a 0 dBi receive antenna.</p> <p><b>Note 2:</b> Throughout these test procedures an additional 1 dB has been added to the amplitude of the test transmission waveforms to account for variations in measurement equipment. This will ensure that the test signal is at or above the detection threshold level to trigger a DFS response.</p> <p><b>Note3:</b> EIRP is based on the highest antenna gain. For MIMO devices refer to KDB Publication 662911 D01.</p>	

**Table 4: DFS Response Requirement Values**

Parameter	Value
<i>Non-occupancy period</i>	Minimum 30 minutes
<i>Channel Availability Check Time</i>	60 seconds
<i>Channel Move Time</i>	10 seconds See Note 1.
<i>Channel Closing Transmission Time</i>	200 milliseconds + an aggregate of 60 milliseconds over remaining 10 second period. See Notes 1 and 2.
<i>U-NII Detection Bandwidth</i>	Minimum 100% of the U-NII 99% transmission power bandwidth. See Note 3.

**Note 1:** *Channel Move Time* and the *Channel Closing Transmission Time* should be performed with Radar Type 0. The measurement timing begins at the end of the Radar Type 0 burst.

**Note 2:** The *Channel Closing Transmission Time* is comprised of 200 milliseconds starting at the beginning of the *Channel Move Time* plus any additional intermittent control signals required to facilitate a *Channel* move (an aggregate of 60 milliseconds) during the remainder of the 10 second period. The aggregate duration of control signals will not count quiet periods in between transmissions.

**Note 3:** During the *U-NII Detection Bandwidth* detection test, radar type 0 should be used. For each frequency step the minimum percentage of detection is 90 percent. Measurements are performed with no data traffic.

**Table 5 – Short Pulse Radar Test Waveforms**

Radar Type	Pulse Width (μsec)	PRI (μsec)	Number of Pulses	Minimum Percentage of Successful Detection	Minimum Number of Trials
0	1	1428	18	See Note 1	See Note 1
1	1	Test A: 15 unique PRI values randomly selected from the list of 23 PRI values in Table 5a	Roundup $\left\{ \begin{array}{l} \left( \frac{1}{360} \right) \cdot \\ \left( \frac{19 \cdot 10^6}{\text{PRI}_{\mu\text{sec}}} \right) \end{array} \right\}$	60%	30
		Test B: 15 unique PRI values randomly selected within the range of 518-3066 μsec, with a minimum increment of 1 μsec, excluding PRI values selected in Test A			
2	1-5	150-230	23-29	60%	30
3	6-10	200-500	16-18	60%	30
4	11-20	200-500	12-16	60%	30
Aggregate (Radar Types 1-4)				80%	120
<b>Note 1:</b> Short Pulse Radar Type 0 should be used for the detection bandwidth test, channel move time, and channel closing time tests.					

**Table 6 – Long Pulse Radar Test Waveform**

Radar Type	Pulse Width (μsec)	Chirp Width (MHz)	PRI (μsec)	Number of Pulses per Burst	Number of Bursts	Minimum Percentage of Successful Detection	Minimum Number of Trials
5	50-100	5-20	1000-2000	1-3	8-20	80%	30

**Table 7 – Frequency Hopping Radar Test Waveform**

Radar Type	Pulse Width (μsec)	PRI (μsec)	Pulses per Hop	Hopping Rate (kHz)	Hopping Sequence Length (msec)	Minimum Percentage of Successful Detection	Minimum Number of Trials
6	1	333	9	0.333	300	70%	30

#### 3.6.4 Overview Of EUT With Respect To 15.407(H) Requirements.

- The EUT operates over the 5250-5350MHz range was a slave device associated with the master during these tests and it did not have radar detection + capability.
- The EUT uses a transmitter connected to 50-ohm coaxial antenna ports via a diversity switch. Only one antenna port is connected to the test system since the EUT has an antenna only.
- The Slave device associated with the EUT during these tests does not have radar detection + capability.
- WLAN traffic is generated by the Iperf.exe. The traffic load flow from the Master to the Slave.
- The rated output power of the Master equipment is <23dBm (EIRP). Therefore the required interference threshold level is -62 dBm.

#### 3.6.5 Support Equipment

Support Equipment				
No.	Equipment	Brand Name	Model Name	Remarks
1	Notebook	Lenovo	L450	/

#### 3.6.6 Test Procedure

Test Method	
<input checked="" type="radio"/> Conducted Measurement	<input type="radio"/> Radiated Measurement
Test Bandwidth	
<input type="radio"/> All the Bandwidth	<input checked="" type="radio"/> Highest Channel
Environmental conditions	
<input checked="" type="radio"/> Normal	<input type="radio"/> Normal and Extreme
Note: ●:Test    ○:No Test	

### 3.6.7 Calibration of DFS detection threshold level

- a. A 50 ohm load is connected in place of the spectrum analyzer, and the spectrum analyzer is connected in place of the master device and the signal generator is set to CW mode. The amplitude of the signal generator is adjusted to yield a level of  $-62\text{dBm}$  as measured on the spectrum analyzer.
- b. The rated output power of the Master equipment is  $<23\text{dBm}$  (EIRP). Therefore the required interference threshold level is  $-62\text{ dBm}$ . Without changing any of the instrument settings, the spectrum analyzer is reconnected to the Common port of the Spectrum Analyzer Combiner/Divider. Measure the amplitude and calculate the difference from  $-62\text{ dBm}$ . Adjust the Reference Level Offset of the spectrum analyzer to this difference.
- c. The spectrum analyzer displays the level of the signal generator as received at the antenna ports of the Master Device. The interference detection threshold may be varied from the calibrated value of  $-62\text{ dBm}$  and the spectrum analyzer will still indicate the level as received by the Master Device.
- d. Set the signal generator to produce a radar waveform, trigger a burst manually and measure the level on the spectrum analyzer. Readjust the amplitude of the signal generator as required so that the peak level of the waveform is at a displayed level equal to the required or desired interference detection threshold. Separate signal generator amplitude settings are determined as required for each radar type.

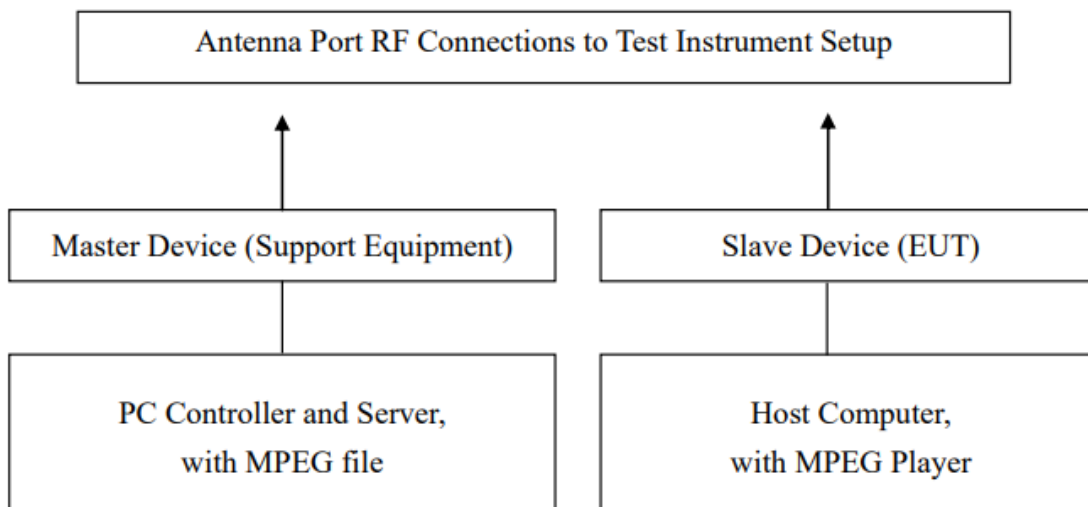

### 3.6.8 Test Setup

#### 7.2.2 Setup for Client with injection at the Master

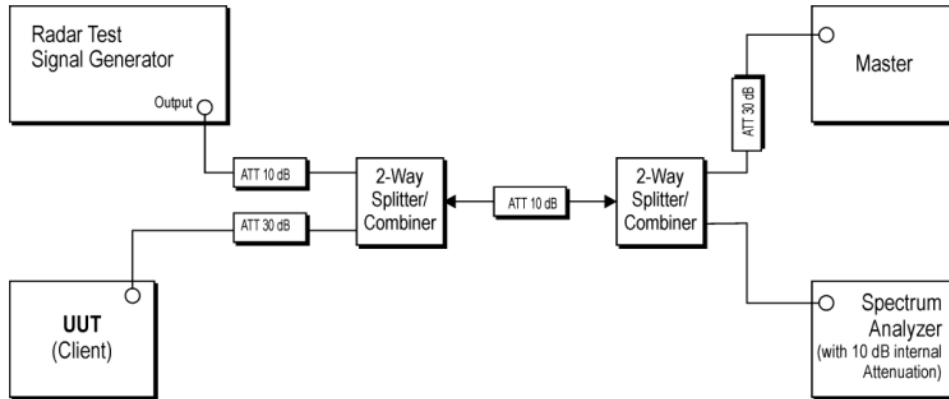

*Figure 3: Example Conducted Setup where UUT is a Client and Radar Test Waveforms are injected into the Master*

### 3.6.9 Test Result

#### 3.6.9.1 DFS Detection Threshold

Test Mode	Frequency[MHz]	Radar Type	Result	Limit[dbm]	Verdict
11Ax20	5260	Type0	-62.26	-62.00	PASS
		Type1	-62.13	-62.00	PASS
		Type2	-62.12	-62.00	PASS
		Type3	-62.33	-62.00	PASS
		Type4	-62.01	-62.00	PASS
		Type5	-62.12	-62.00	PASS
		Type6	-62.15	-62.00	PASS
11Ax80	5610	Type0	-62.17	-62.00	PASS
		Type1	-62.11	-62.00	PASS
		Type2	-62.21	-62.00	PASS
		Type3	-62.39	-62.00	PASS
		Type4	-62.38	-62.00	PASS
		Type5	-62.37	-62.00	PASS
		Type6	-62.48	-62.00	PASS

### Test Graphs

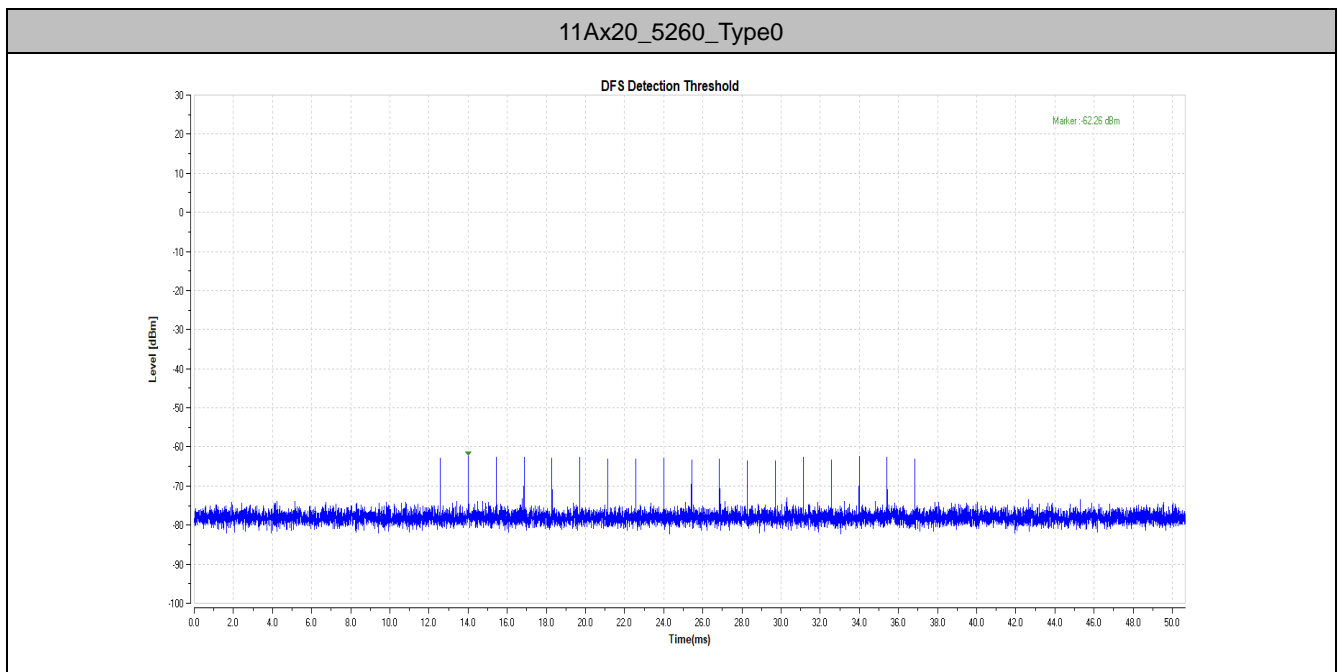

11Ax20\_5260\_Type1

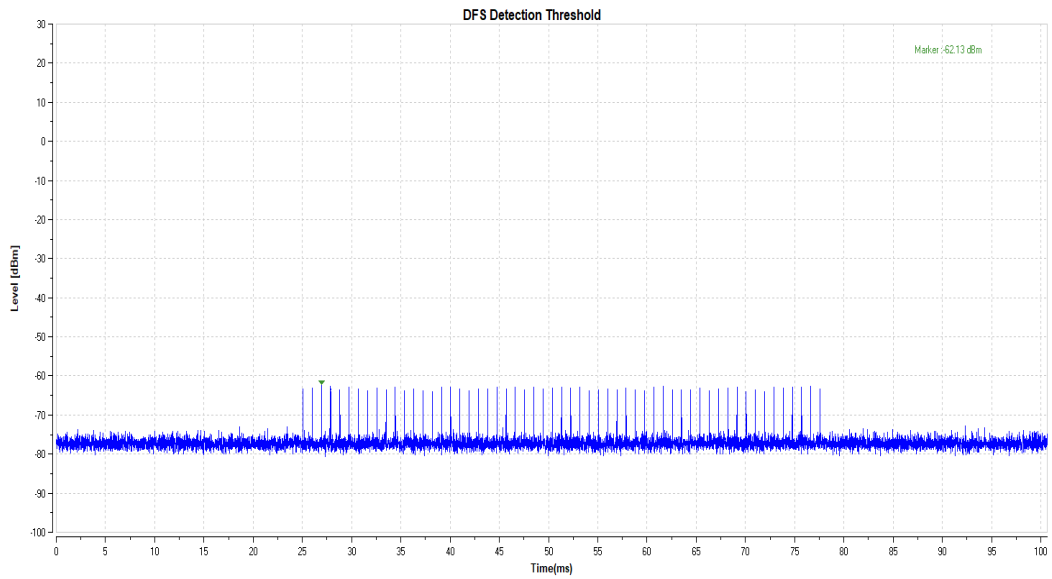

11Ax20\_5260\_Type2

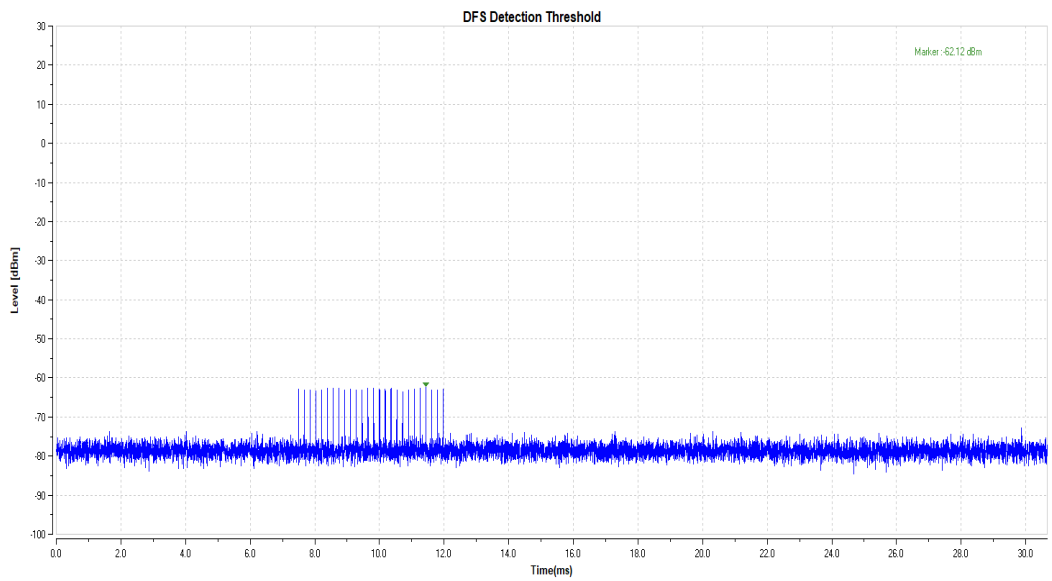

11Ax20\_5260\_Type3

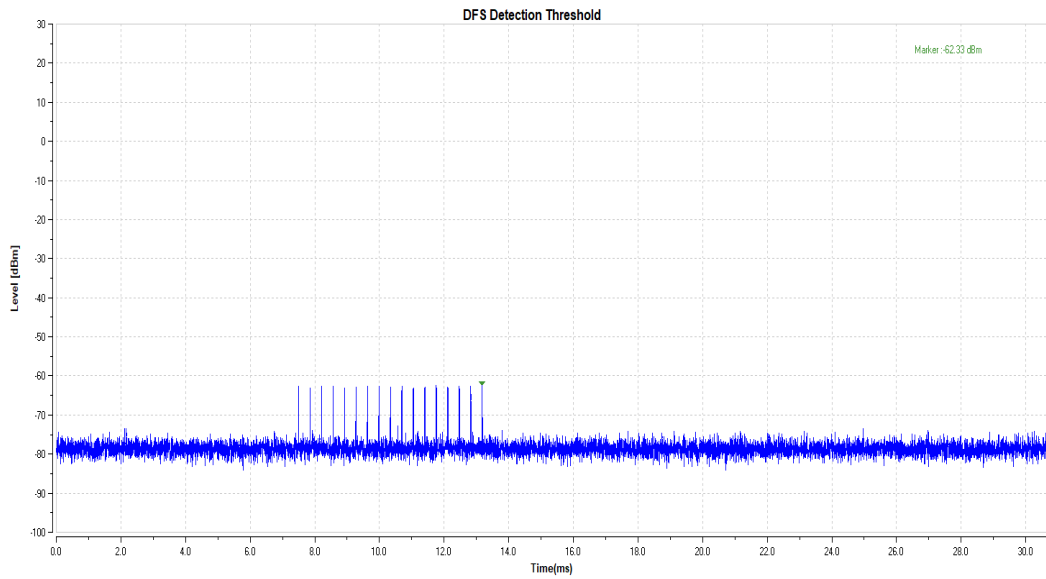

11Ax20\_5260\_Type4

