

***BRIO Satellite***

**Exhibit 2**

**File #: 0220-EX-CN-2018**

**Technical Information**

March 7, 2018

May 8, 2018 (Rev A)

Submitted By

**SpaceQuest, Ltd.**

3554 Chain Bridge Road

Suite 400

Fairfax, VA 22030

## Table of Contents

<b>1</b>	<b>Ownership, Operations and Construction</b> .....	<b>3</b>
<b>2</b>	<b>Orbital Requirements</b> .....	<b>3</b>
<b>3</b>	<b>Service Area</b> .....	<b>3</b>
<b>4</b>	<b>Satellite Payload</b> .....	<b>3</b>
<b>5</b>	<b>Principle Specifications</b> .....	<b>4</b>
<b>6</b>	<b>System Block Diagram</b> .....	<b>4</b>
<b>7</b>	<b>Telemetry, Tracking &amp; Command and Payload Operations</b> .....	<b>6</b>
<b>8</b>	<b>Radio Equipment</b> .....	<b>6</b>
8.1	UHF TT&C Transceiver.....	6
8.2	VHF Receiver: .....	7
8.3	S-Band Transceiver:.....	7
8.4	UHF Experimental Payload Transceiver.....	7
<b>9</b>	<b>Antenna Systems</b> .....	<b>8</b>
<b>10</b>	<b>Satellite Link Budgets</b> .....	<b>9</b>
<b>11</b>	<b>Interference Analysis</b> .....	<b>14</b>
11.1	400.50-400.65 MHz (TT&C and Experimental Downlink).....	14
11.2	399.90 -400.05 MHz (TT&C and Experimental Uplink).....	14
11.3	2200-2290 MHz (Payload Downlink) .....	14
11.4	2025-2110 MHz (Payload Uplink).....	15
<b>12</b>	<b>Power Flux Density Analysis</b> .....	<b>15</b>
12.1	400.50-400.65 MHz (TT&C Downlink) .....	15
12.2	2200-2290 MHz (S-Band Downlink).....	16
12.3	400.50-400.65 MHz (Experimental Payload Downlink) .....	16
<b>13</b>	<b>Space Station Antenna Radiation Patterns</b> .....	<b>17</b>
13.1	S-Band: BRIO Space Station Transmit/Receive Antenna .....	17
13.2	UHF: BRIO Space Station TT&C Transmit/Receive Antenna.....	17
13.3	VHF: BRIO Space Station Receive Antenna .....	18
13.4	UHF: BRIO Space Station Experimental UHF Receive/Transmit Antenna .....	18
13.5	Summary of BRIO Antenna Characteristics.....	19
<b>14</b>	<b>Earth Station Antenna Radiation Patterns</b> .....	<b>19</b>
14.1	UHF TT&C Antennas in Fairfax, VA, North Pole, AK, Naalehu, HI and Limestone, ME .....	19
14.2	VHF Backup Antennas in Fairfax, VA, North Pole, AK, Naalehu, HI and Limestone, ME .....	20
14.3	S-Band Antennas in Inuvik, Canada and Esrange, Sweden .....	20
14.4	UHF Experimental Antenna .....	21
<b>15</b>	<b>Stop Buzzer POC</b> .....	<b>21</b>

## List of Figures

Figure 1 Orbital Parameters.....	3
Figure 2 System Block Diagram.....	5
Figure 3 Isometric view of deployed configuration.....	5
Figure 4 Summary of BRIO Transmitter and Receiver parameters. ....	8
Figure 5 Antenna Frequency Registration .....	8
Figure 6 Frequency Emissions Registration .....	8
Figure 7 Satellite UHF TT&C Uplink Budget .....	9
Figure 8 Satellite UHF TT&C Downlink Budget .....	9
Figure 9 Satellite S-Band Uplink Budget .....	10
Figure 10 Satellite S-Band Downlink Budget .....	10
Figure 11 Satellite Experimental UHF Uplink Budget .....	11
Figure 12 Satellite Experimental UHF Downlink Budget .....	11
Figure 13 Satellite VHF Uplink Budget.....	12
Figure 14 Satellite VHF Link Margins Vs. Elevation Angle .....	12
Figure 15 Satellite UHF TT&C Link Margins Vs. Elevation Angle .....	13
Figure 16 Satellite S-Band Link Margins Vs. Elevation Angle.....	13
Figure 17 Satellite UHF Experimental Radio Link Margins Vs. Elevation Angle.....	14
Figure 18 PFD at the Surface of the Earth for the UHF Transmitter.....	15
Figure 19 PFD at the Surface of the Earth for the S-Band Transmitter .....	16
Figure 20 PFD at the Surface of the Earth for the UHF Payload Transmitter .....	16
Figure 21 S-Band Satellite Transmit/Receive Antenna Radiation Pattern .....	17
Figure 22 TT&C UHF Satellite Transmit/Receive Antenna Radiation Pattern. ....	17
Figure 23 VHF Satellite Receive Antenna Radiation Pattern .....	18
Figure 24 Experimental UHF Satellite Transmit/Receive Antenna Radiation Pattern .....	18
Figure 25 BRIO Antenna Characteristics.....	19
Figure 26 UHF Earth Station Antenna Radiation Pattern. ....	19
Figure 27 VHF Earth Station Antenna Radiation Pattern.....	20
Figure 28 S-Band Earth Station Antenna Radiation Pattern.....	20
Figure 29 UHF Experimental Earth Station Antenna Radiation Pattern.....	21

## 1 Ownership, Operations and Construction.

SpaceQuest, Ltd. is a small business concern, and the owner, manufacturer and operator of the BRIO satellite. SpaceQuest has selected Spaceflight Industries of Seattle, Washington as the launch provider. BRIO will be launched on a SpaceX Falcon 9 launch vehicle from Vandenberg, AFB in California (geographic coordinates 34.5762°N; 4.2803°W) in October 2018. Pursuant to Part 5 §5.64 of the Commission’s Rules, construction of the proposed experimental satellite and associated facilities has begun prior to the Commission’s grant of an authorization. This is necessary given the nature of satellite construction and technical requirements over long lead times. Such construction is entirely at SpaceQuest’s risk without any assurances that its proposed experiment will be subsequently approved.

- Space Station Name: BRIO
- BRIO Estimated Construction Completion Date: August 2018
- Spaceflight Final Certification of Licenses (Go/NoGo): September 1, 2018
- Purpose: Experimental, non-Common Carrier basis
- Orbital Type: NGSO

## 2 Orbital Requirements.

The satellite is designed to operate in a circular sun-synchronous orbit as described in Figure 1. The satellites are based on COTS technology that allows for small, lightweight and low-cost spacecraft.

BRIO	Value
Total Number of Orbital Planes:	1
Celestial Reference Body:	Earth
Inclination Angle (degrees):	97.52
Orbital Period (seconds)	5760
Apogee	575 km
Perigee	575 km

*Figure 1 Orbital Parameters*

## 3 Service Area.

Worldwide

## 4 Satellite Payload.

The primary satellite mission of BRIO is to investigate, identify and resolve potential technical and implementation issues with its advanced satellite SDR radio design developed by Myriota.

Another important objective is to demonstrate the ability to upload and run new firmware that can introduce new features to the SDR Radio after it is on orbit. The results of this three-phase experiment will (1) demonstrate and validate the ability to uplink large numbers of

messages to a satellite using a single channel, (2) demonstrate the ability to downlink messages to different ground devices on a single channel, and (3) implement an advanced signal processing algorithm on board a satellite to provide highly spectrally efficient bidirectional communications.

The secondary satellite mission of BRIO is to test a backup receiver developed by SpaceQuest to send executive commands, to reboot the satellite flight computer, or to cycle the spacecraft power bus in the event of a system failure. As a components manufacturer, it is expected that the outcome of this testing will result in a significant advancement in satellite radio equipment technology.

The BRIO UHF frequency assignment will be used for satellite telemetry, command and control. The S-Band assignment will be used to download selected mission data from the Myriota payload and upload new computer firmware to improve performance and correct any software deficiencies.

## **5 Principle Specifications.**

BRIO is a 3U CubeSat whose outside envelope measures 100 x 100 x 340.5mm. The satellite's total mass is 5 kg. It has four deployable solar arrays, which deploy from the short edges of the spacecraft. The Lilon battery consists of eight cells wired as 4-series and 2 parallel. The expected mission lifetime is 5 years in a 575-km orbit due to battery life and deorbit analysis. SpaceQuest will own and operate the experimental CubeSat throughout its mission lifetime. The BRIO satellite will not be sold or transferred to another party.

## **6 System Block Diagram.**

Figure 2 below shows the major components of the spacecraft and their interfaces. The flight computer is responsible for TT&C and payload scheduling. The attitude determination and control system orients the solar panels to the sun, except when the satellite is re-oriented to communicate with a ground station. The Software Defined Radio implements the S-Band transceiver. The deployed array and antenna configuration is shown in Figure 3.

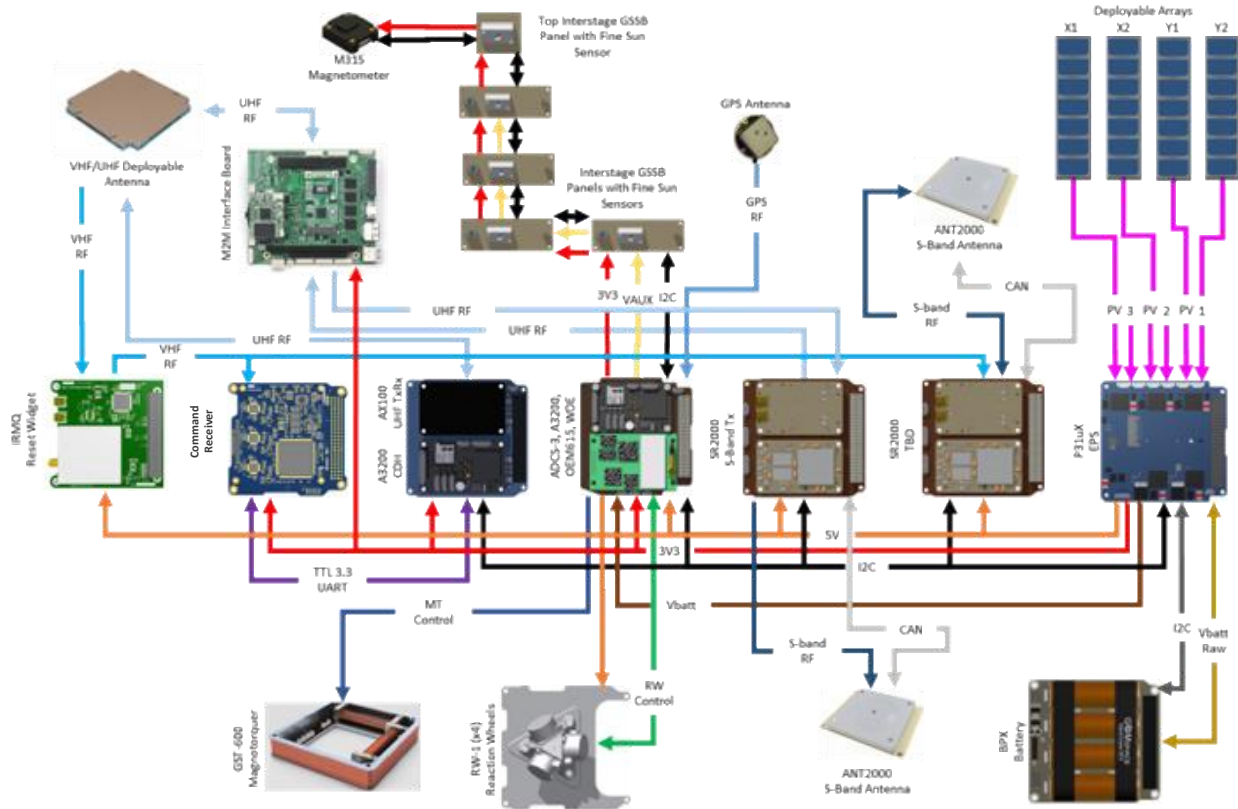

Figure 2 System Block Diagram

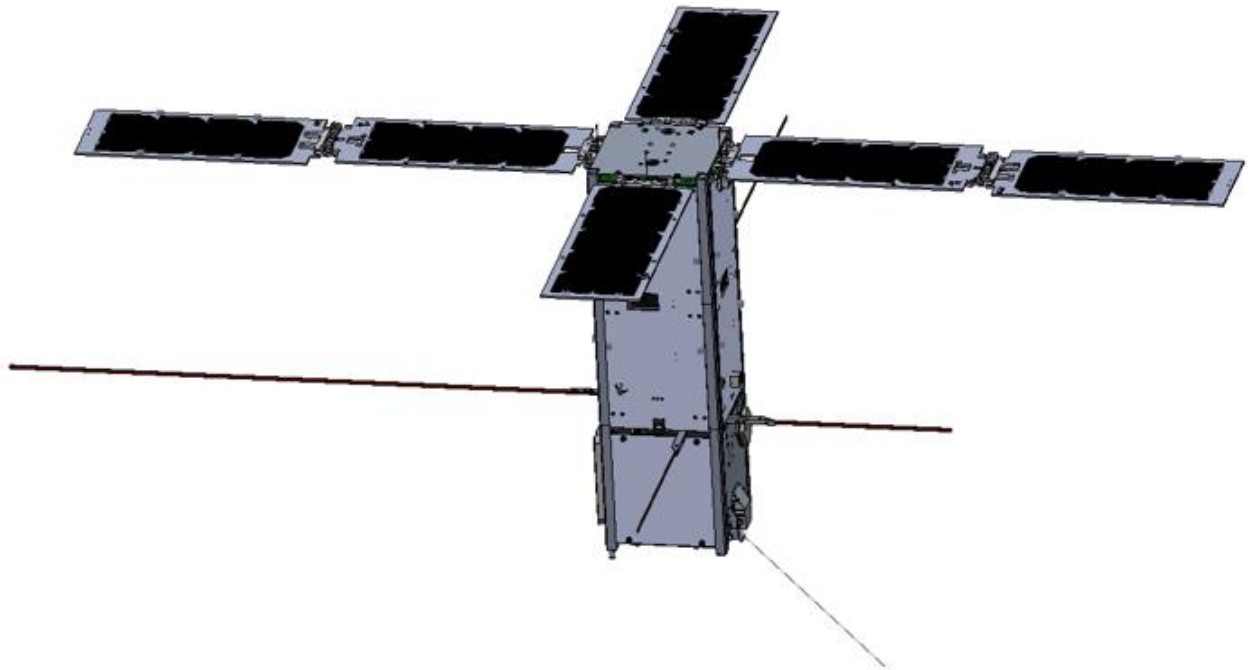

Figure 3 Isometric view of deployed configuration.

This configuration allows for two VHF and two UHF monopole antennas deployed from the body of the spacecraft. One UHF antenna is used for TT&C communication. The second UHF antenna is grounded. A third UHF antenna that is deployed from the side of the satellite when the solar panels are deployed is for a UHF SDR transceiver, which is a part of the experimental communications payload being evaluated for the hosted Myriota payload.

The receive-only VHF monopole antennas are used to test a new backup receiver design to send executive commands to reboot the satellite flight computer in the event of a system failure.

## 7 Telemetry, Tracking & Command and Payload Operations

The space-to-Earth downlink frequency band of 400.50-400.65 MHz and the Earth-to-space uplink frequency band of 399.90-400.05 MHz for TT&C communications will communicate with SpaceQuest's Earth stations in Fairfax, Virginia, Naalehu, Hawaii, North Pole, Alaska, and Limestone, Maine. The SpaceQuest TT&C Earth stations will also have the capability to uplink executive commands to a backdoor command receiver at 145.92 MHz.

The second UHF Transceiver used to evaluate Myriota's advanced communications processor will also operate in the space-to-Earth downlink frequency band of 400.50-400.65 MHz and the Earth-to-space uplink frequency band of 399.90-400.05 MHz.

The space-to-Earth frequency band of 2200-2290 MHz will be used to downlink experimental test data to Earth Stations in Inuvik, Canada and Esrange, Sweden. The Earth-to-space uplink frequency band of 2025-2110 MHz from Inuvik, Canada and Esrange, Sweden will be used occasionally to upload new firmware to the Myriota payload.

## 8 Radio Equipment.

### 8.1 UHF TT&C Transceiver

- NanoComm AX100 UHF Transceiver manufactured by GomSpace.
- Primary transceiver capability for telecommand, telemetry, and schedule uploads.
- The transceiver can operate between 390 MHz and 406 MHz at 9600 bps modulation.

#### 8.1.1 Downlink: UHF Transmit

- Operating Frequency 400.60 MHz
- Output Power: 3 Watts
- EIRP: 3.3 dBW
- Channels: 400.50-400.65 MHz
- Frequency Deviation: 16 kHz

#### 8.1.2 Uplink: UHF Receive

- Operating Frequency 399.95 MHz
- Sensitivity: -110 dBm
- Channels: 399.90-400.05 MHz
- Frequency Stability:  $\pm 10$  ppm.

## 8.2 VHF Receiver:

- CERX-145 Narrowband FM Receiver manufactured by SpaceQuest
- Experimental backup VHF Receiver for emergency reboot or satellite power cycle
- 145.92 MHz fixed receive frequency
- GMSK modulation at 9600bps
- Sensitivity: -119 dBm

## 8.3 S-Band Transceiver:

- GomSpace TR600 S-Band SDR Transceiver
- Primary transceiver for mission data and commands to primary payload
- Space-to-Earth downlink operates in the 2200-2290 MHz frequency band
- Earth-to-space uplink operated in the 2025-2110 MHz frequency band
- 700 Kbps data rate with QPSK modulation

### 8.3.1 Downlink: S-Band Transmit

- Requested Frequency Band: 1MHz in the 2200-2290 MHz band
- Output Power: 1 Watts
- Peak antenna Gain: 7 dBi
- EIRP: 3.3 dBW
- Data Rate: 700 kbps
- Channels: Antenna Operating Frequency: 2200-2290 MHz
- Necessary Bandwidth: 1,000 kHz

### 8.3.2 Uplink: S-Band Receive

- Operating Frequency: 1MHz in the 2025-2110 MHz band
- Sensitivity: -100 dBm
- Data Rate: 700 kbps
- Channels: Antenna Operating Frequency: 2015-2110 MHz
- Frequency Stability:  $\pm 10$  ppm

## 8.4 UHF Experimental Payload Transceiver

- ERP-100 UHF Transceiver manufactured by SpaceQuest
- UHF transceiver to be used with Myriota's experimental payload processor
- The transceiver can operate between 390 MHz and 406 MHz at 9600 bps
- Modulation is FM/GMSK

### 8.4.1 Downlink: UHF Transmit

- Operating Frequency 400.60 MHz
- Output Power: 4 Watts
- EIRP: 4.5 dBW
- Channels: 400.50-400.65 MHz
- Frequency Deviation: 16 kHz



### 8.4.2 Uplink: UHF Receive

- Operating Frequency 399.95 MHz
- Sensitivity: -112 dBm
- Channels: Tunable SDR
- Frequency Stability:  $\pm 10$  ppm

A summary of the BRIO Transmitter and Receiver parameters are provided in Figure 4.

Description	Transmitter 1	Transmitter 2	Transmitter 3	Receiver 1	Receiver 2	Receiver 3	Receiver 4
Radio Name	UTX	SBTX	EXTX	URX	SBRX	EXRX	VRX
Carrier Frequency, MHz	400.6	~ 2288.5	400.60	399.95	~ 2045.5	399.95	145.92
3 dB Bandwidth, MHz	0.015	0.75	0.015	0.015	0.75	0.015	0.015
Necessary Bandwidth, MHz	0.035	1.0	0.035	0.035	1.0	0.035	0.025
20 dB Bandwidth, MHz	0.020	0.80	0.020	NA	NA	NA	NA
60 dB Bandwidth, MHz	0.035	0.90	0.035	NA	NA	NA	NA
Receiver Sensitivity, dBm	NA	NA	NA	-110	-100	-112	-119
Antenna Gain, dBi	0.0	7.0	0.0	0.0	7.0	0.0	0.0
Modulation Type	GMSK	QPSK	GMSK	GMSK	QPSK	GMSK	GMSK
Total Data Rate (KHz)	9.6	700	9.6	9.6	700	9.6	9.6
Receiver Span (MHz)	NA	NA	NA	0.15	1.0	0.15	0.05
EIRP, dBW	3.3	3.4	4.5	NA	NA	NA	NA
Antenna Polarization	Linear	Circular	Linear	Linear	Circular	Linear	Linear

Figure 4 Summary of BRIO Transmitter and Receiver parameters.

## 9 Antenna Systems

The antenna frequency parameters for the BRIO Satellite are provided in Figure 5.

Beam	Lower Frequency	Upper Frequency	Freq. Units	Power	Power Units	Output Power/ERP	ERP Units	Mean/Peak	Frequency Tolerance	Station Class
SBTX	2200	2290	MHz	1.0	W	3.4	dBW	Peak	+/-10 ppm	Mobile
UTX	400.50	400.65	MHz	3.0	W	3.3	dBW	Peak	+/-10 ppm	Mobile
EXTX	400.50	400.65	MHz	4.0	W	4.5	dBW	Peak	+/-10 ppm	Mobile

Figure 5 Antenna Frequency Registration

The antenna emission parameters for the BRIO Satellite are provided in Figure 6.

Beam	Lower Frequency	Upper Frequency	Units	Emission	Modulating Signal	Necessary Bandwidth
SBTX	2200	2290	MHz	1M00G1D	QPSK	1,000 KHz
UTX	400.50	400.65	MHz	35K0F1D	GMSK	35 KHz
EXTX	400.50	400.65	MHz	35K0F1D	GMSK	35 KHz

Figure 6 Frequency Emissions Registration

## 10 Satellite Link Budgets

The UHF TT&C uplink budget is shown in Figure 7. Figure 8 shows the TT&C downlink budget.

<b>UHF</b>		<b>Uplink Budget</b>							<b>2/26/18</b>
<b>ELEVATION ANGLE TO SATELLITE (Deg)</b>	<b>5</b>	<b>10</b>	<b>20</b>	<b>30</b>	<b>45</b>	<b>60</b>	<b>75</b>	<b>90</b>	
ORBITAL ALTITUDE (km)	575	575	575	575	575	575	575	575	
EARTH'S RADIUS (km)	6378	6378	6378	6378	6378	6378	6378	6378	
COVERAGE HALF ANGLE TO HORIZON (Deg)	67	67	67	67	67	67	67	67	
SLANT RANGE TO SATELLITE (km)	2268	1874	1343	1034	782	655	594	575	
SURFACE DISTANCE FROM RECEIVER TO SSP (km)	2111	1714	1164	824	508	301	141	0	
<b>Ground Transmitter</b>									
<b>TRANSMITTER FREQUENCY (MHz)</b>	<b>399.95</b>	<b>399.95</b>	<b>399.95</b>	<b>399.95</b>	<b>399.95</b>	<b>399.95</b>	<b>399.95</b>	<b>399.95</b>	
GROUND TRANSMITTER POWER (Watts)	10.0	10.0	10.0	10.0	10.0	10.0	10.0	10.0	
GROUND TRANSMITTER POWER (dB)	10.0	10.0	10.0	10.0	10.0	10.0	10.0	10.0	
TRANSMISSION LINE LOSS (dB)	1.5	1.5	1.5	1.5	1.5	1.5	1.5	1.5	
ANTENNA GAIN (dBi)	13.5	13.5	13.5	13.5	13.5	13.5	13.5	13.5	
GROUND TRANSMITTER EIRP (dBw)	22.0	22.0	22.0	22.0	22.0	22.0	22.0	22.0	
<b>Satellite Receiver</b>									
FREE SPACE LOSS (dB)	151.6	149.9	147.0	144.7	142.3	140.8	139.9	139.6	
ISOTROPIC POWER AT SATELLITE ANTENNA (dB)	-129.6	-127.9	-125.0	-122.7	-120.3	-118.8	-117.9	-117.6	
SATELLITE RECEIVER ANTENNA GAIN (dBi)	0.0	0.0	0.0	0.0	0.0	0.0	0.0	0.0	
POLARIZATION LOSS (dB)	3.0	3.0	3.0	3.0	3.0	3.0	3.0	3.0	
IMPLEMENTATION LOSS (dB)	1.0	1.0	1.0	1.0	1.0	1.0	1.0	1.0	
SYSTEM NOISE TEMPERATURE (K)	400	400	400	400	400	400	400	400	
FRONT END GAIN (Ant Gain-Losses) (dB)	-4.0	-4.0	-4.0	-4.0	-4.0	-4.0	-4.0	-4.0	
FRONT END G/T (dB/K)	-30.0	-30.0	-30.0	-30.0	-30.0	-30.0	-30.0	-30.0	
BOLTZMAN'S CONSTANT (dB)	-228.6	-228.6	-228.6	-228.6	-228.6	-228.6	-228.6	-228.6	
UPLINK C/No (dB-Hz)	69.0	70.7	73.6	75.8	78.3	79.8	80.7	80.9	
DATA RATE (bps)	9600	9600	9600	9600	9600	9600	9600	9600	
Eb/No (dB)	29.2	30.9	33.8	36.0	38.5	40.0	40.8	41.1	
Eb/No REQUIRED FOR BER OF 10 <sup>-5</sup> (dB)	11.5	11.5	11.5	11.5	11.5	11.5	11.5	11.5	
<b>UPLINK MARGIN (dB)</b>	<b>17.7</b>	<b>19.4</b>	<b>22.3</b>	<b>24.5</b>	<b>27.0</b>	<b>28.5</b>	<b>29.3</b>	<b>29.6</b>	

Figure 7 Satellite UHF TT&C Uplink Budget

<b>UHF</b>		<b>Downlink Budget</b>							<b>2/26/18</b>
<b>ELEVATION ANGLE TO SATELLITE (Deg)</b>	<b>5</b>	<b>10</b>	<b>20</b>	<b>30</b>	<b>45</b>	<b>60</b>	<b>75</b>	<b>90</b>	
ORBITAL ALTITUDE (km)	575	575	575	575	575	575	575	575	
EARTH'S RADIUS (km)	6378	6378	6378	6378	6378	6378	6378	6378	
COVERAGE HALF ANGLE TO HORIZON (Deg)	67	67	67	67	67	67	67	67	
SLANT RANGE TO SATELLITE (Km)	2268	1874	1343	1034	782	655	594	575	
SURFACE DISTANCE FROM RECEIVER TO SSP (km)	2111	1714	1164	824	508	301	141	0	
<b>Satellite Transmitter</b>									
<b>SATELLITE DOWNLINK FREQUENCY (MHz)</b>	<b>400.60</b>	<b>400.60</b>	<b>400.60</b>	<b>400.60</b>	<b>400.60</b>	<b>400.60</b>	<b>400.60</b>	<b>400.60</b>	
TRANSMITTER OUTPUT POWER (Watts)	3.0	3.0	3.0	3.0	3.0	3.0	3.0	3.0	
TRANSMITTER OUTPUT POWER (dBw)	4.8	4.8	4.8	4.8	4.8	4.8	4.8	4.8	
IMPLEMENTATION LOSS (dB)	1.5	1.5	1.5	1.5	1.5	1.5	1.5	1.5	
SATELLITE TRANSMIT ANTENNA GAIN (dB)	0.0	0.0	0.0	0.0	0.0	0.0	0.0	0.0	
SATELLITE DOWNLINK EIRP (Watts)	2.1	2.1	2.1	2.1	2.1	2.1	2.1	2.1	
SATELLITE DOWNLINK EIRP (dBw)	3.3	3.3	3.3	3.3	3.3	3.3	3.3	3.3	
<b>Ground Receiver</b>									
FREE SPACE LOSS (dB)	151.6	149.9	147.0	144.7	142.3	140.8	139.9	139.6	
ISOTROPIC POWER AT MOBILE ANTENNA (dBw)	-148.3	-146.6	-143.7	-141.5	-139.0	-137.5	-136.7	-136.4	
GROUND ANTENNA GAIN (dB)	13.5	13.5	13.5	13.5	13.5	13.5	13.5	13.5	
POLARIZATION LOSS (dB)	3.0	3.0	3.0	3.0	3.0	3.0	3.0	3.0	
TRANSMISSION LINE LOSS (dB)	1.0	1.0	1.0	1.0	1.0	1.0	1.0	1.0	
SYSTEM NOISE TEMPERATURE (K)	290	290	290	290	290	290	290	290	
FRONT END GAIN (Ant Gain-Losses) (dB)	9.5	9.5	9.5	9.5	9.5	9.5	9.5	9.5	
FRONT END G/T (dB/K)	-15.1	-15.1	-15.1	-15.1	-15.1	-15.1	-15.1	-15.1	
BOLTZMAN'S CONSTANT (dB)	-228.6	-228.6	-228.6	-228.6	-228.6	-228.6	-228.6	-228.6	
DOWNLINK C/No (dB-Hz)	65.2	66.8	69.7	72.0	74.4	76.0	76.8	77.1	
DATA RATE (bps)	9600	9600	9600	9600	9600	9600	9600	9600	
Eb/No (dB)	25.4	27.0	29.9	32.2	34.6	36.1	37.0	37.3	
Eb/No REQUIRED FOR GMSK BER of 10 <sup>-5</sup> (dB)	11.5	11.5	11.5	11.5	11.5	11.5	11.5	11.5	
<b>DOWNLINK MARGIN (dB)</b>	<b>13.9</b>	<b>15.5</b>	<b>18.4</b>	<b>20.7</b>	<b>23.1</b>	<b>24.6</b>	<b>25.5</b>	<b>25.8</b>	

Figure 8 Satellite UHF TT&C Downlink Budget

The S-Band uplink budget is shown in Figure 9. The S-Band downlink budget is Figure 10.

<b>S-Band</b>		<b>Uplink Budget</b>							4/26/18
<b>ELEVATION ANGLE TO SATELLITE (Deg)</b>	<b>1</b>	<b>5</b>	<b>15</b>	<b>25</b>	<b>40</b>	<b>60</b>	<b>75</b>	<b>90</b>	
ORBITAL ALTITUDE (km)	575	575	575	575	575	575	575	575	
EARTH'S RADIUS (km)	6378	6378	6378	6378	6378	6378	6378	6378	
COVERAGE HALF ANGLE TO HORIZON (Deg)	67	67	67	67	67	67	67	67	
SLANT RANGE TO SATELLITE (km)	2660	2268	1573	1169	847	655	594	575	
SURFACE DISTANCE to SSP (km)	2503	2111	1405	975	596	301	141	0	
		0.0							
<b>Ground Transmitter</b>		0							
<b>TRANSMITTER FREQUENCY (MHz)</b>	<b>2045.5</b>	<b>2045.5</b>	<b>2045.5</b>	<b>2045.5</b>	<b>2045.5</b>	<b>2045.5</b>	<b>2045.5</b>	<b>2045.5</b>	
GROUND TRANSMITTER POWER (Watts)	10	10	10	10	10	10	10	10	
GROUND TRANSMITTER POWER (dB)	10.0	10.0	10.0	10.0	10.0	10.0	10.0	10.0	
TRANSMISSION LINE LOSS (dB)	1.5	1.5	1.5	1.5	1.5	1.5	1.5	1.5	
ANTENNA GAIN (dBi) (10-ft dish @ 50% efficiency)	40.0	40.0	40.0	40.0	40.0	40.0	40.0	40.0	
GROUND TRANSMITTER EIRP (dBw)	48.5	48.5	48.5	48.5	48.5	48.5	48.5	48.5	
<b>Satellite Receiver</b>									
FREE SPACE LOSS (dB)	167.1	165.7	162.5	160.0	157.2	154.9	154.1	153.8	
ISOTROPIC POWER AT SAT ANTENNA (dB)	-119	-117	-114	-111	-109	-106	-106	-105	
SATELLITE RECEIVER ANTENNA GAIN (dBi)	3.0	3.0	3.0	3.0	3.0	3.0	3.0	3.0	
POLARIZATION LOSS (dB)	3.0	3.0	3.0	3.0	3.0	3.0	3.0	3.0	
IMPLEMENTATION LOSS (dB)	1.5	1.5	0.5	0.5	0.5	0.5	0.5	0.5	
SYSTEM NOISE TEMPERATURE (K)	400	400	400	400	400	400	400	400	
FRONT END GAIN (Ant Gain-Losses) (dB)	-1.5	-1.5	-0.5	-0.5	-0.5	-0.5	-0.5	-0.5	
FRONT END G/T (dB/K)	-27.5	-27.5	-26.5	-26.5	-26.5	-26.5	-26.5	-26.5	
BOLTZMAN'S CONSTANT (dB)	-228.6	-228.6	-228.6	-228.6	-228.6	-228.6	-228.6	-228.6	
UPLINK C/No (dB-Hz)	82.5	83.9	88.0	90.6	93.4	95.6	96.5	96.8	
DATA RATE (bps)	700000	700000	700000	700000	700000	700000	700000	700000	
Eb/No (dB)	24.0	25.4	29.6	32.2	35.0	37.2	38.0	38.3	
Eb/No REQUIRED FOR BER OF 10 <sup>-6</sup> (dB)	13.0	13.0	13.0	13.0	13.0	13.0	13.0	13.0	
<b>UPLINK MARGIN (dB)</b>	<b>11.0</b>	<b>12.4</b>	<b>16.6</b>	<b>19.2</b>	<b>22.0</b>	<b>24.2</b>	<b>25.0</b>	<b>25.3</b>	

Figure 9 Satellite S-Band Uplink Budget

<b>S-Band</b>		<b>Downlink Budget</b>							4/26/18
<b>ELEVATION ANGLE TO SATELLITE (Deg)</b>	<b>1</b>	<b>5</b>	<b>15</b>	<b>25</b>	<b>40</b>	<b>60</b>	<b>75</b>	<b>90</b>	
ORBITAL ALTITUDE (km)	575	575	575	575	575	575	575	575	
EARTH'S RADIUS (km)	6378	6378	6378	6378	6378	6378	6378	6378	
COVERAGE HALF ANGLE TO HORIZON (Deg)	67	67	67	67	67	67	67	67	
SLANT RANGE TO SATELLITE (Km)	2660	2268	1573	1169	847	655	594	575	
SURFACE DISTANCE to SSP (km)	2503	2111	1405	975	596	301	141	0	
<b>Satellite Transmitter</b>									
<b>SATELLITE DOWNLINK FREQUENCY (MHz)</b>	<b>2288.5</b>	<b>2288.5</b>	<b>2288.5</b>	<b>2288.5</b>	<b>2288.5</b>	<b>2288.5</b>	<b>2288.5</b>	<b>2288.5</b>	
TRANSMITTER OUTPUT POWER (Watts)	1.0	1.0	1.0	1.0	1.0	1.0	1.0	1.0	
TRANSMITTER OUTPUT POWER (dBw)	0.0	0.0	0.0	0.0	0.0	0.0	0.0	0.0	
TRANSMISSION LINE LOSS	1.6	1.6	1.6	1.6	1.6	1.6	1.6	1.6	
IMPLEMENTATION LOSS (dB)	2.0	2.0	2.0	2.0	2.0	2.0	2.0	2.0	
SATELLITE TRANSMIT ANTENNA GAIN (dB)	7.0	7.0	7.0	7.0	7.0	7.0	7.0	7.0	
SATELLITE DOWNLINK EIRP (Watts)	2.2	2.2	2.2	2.2	2.2	2.2	2.2	2.2	
SATELLITE DOWNLINK EIRP (dBw)	3.4	3.4	3.4	3.4	3.4	3.4	3.4	3.4	
<b>Ground Receiver</b>									
FREE SPACE LOSS (dB)	168.1	166.7	163.5	160.9	158.2	155.9	155.1	154.8	
ISOTROPIC POWER AT MOBILE ANTENNA (dBw)	-164.7	-163.3	-160.1	-157.5	-154.8	-152.5	-151.7	-151.4	
GROUND ANTENNA GAIN (dB)	40.0	40.0	40.0	40.0	40.0	40.0	40.0	40.0	
POLARIZATION LOSS (dB)	3.0	3.0	3.0	3.0	3.0	3.0	3.0	3.0	
TRANSMISSION LINE LOSS (dB)	1.5	1.5	1.5	1.5	1.5	1.5	1.5	1.5	
SYSTEM NOISE TEMPERATURE (K)	290	290	290	290	290	290	290	290	
FRONT END GAIN (Ant Gain-Losses) (dB)	35.5	35.5	35.5	35.5	35.5	35.5	35.5	35.5	
FRONT END G/T (dB/K)	10.9	10.9	10.9	10.9	10.9	10.9	10.9	10.9	
BOLTZMAN'S CONSTANT (dB)	-228.6	-228.6	-228.6	-228.6	-228.6	-228.6	-228.6	-228.6	
DOWNLINK C/No (dB-Hz)	74.8	76.2	79.4	81.9	84.7	87.0	87.8	88.1	
DATA RATE (bps)	700,000	700,000	700,000	700,000	700,000	700,000	700,000	700,000	
Eb/No (dB)	16.3	17.7	20.9	23.5	26.3	28.5	29.4	29.6	
Eb/No REQUIRED FOR GMSK BER OF 10 <sup>-6</sup> (dB)	13.0	13.0	13.0	13.0	13.0	13.0	13.0	13.0	
<b>DOWNLINK MARGIN (dB)</b>	<b>3.3</b>	<b>4.7</b>	<b>7.9</b>	<b>10.5</b>	<b>13.3</b>	<b>15.5</b>	<b>16.4</b>	<b>16.6</b>	

Figure 10 Satellite S-Band Downlink Budget

The UHF Experimental Payload uplink budget is shown in Figure 11.

<b>UHF</b>		<b>Uplink Budget</b>							<b>3/6/18</b>
<b>ELEVATION ANGLE TO SATELLITE (Deg)</b>	<b>5</b>	<b>10</b>	<b>20</b>	<b>30</b>	<b>45</b>	<b>60</b>	<b>75</b>	<b>90</b>	
ORBITAL ALTITUDE (km)	575	575	575	575	575	575	575	575	
EARTH'S RADIUS (km)	6378	6378	6378	6378	6378	6378	6378	6378	
COVERAGE HALF ANGLE TO HORIZON (Deg)	67	67	67	67	67	67	67	67	
SLANT RANGE TO SATELLITE (km)	2268	1874	1343	1034	782	655	594	575	
SURFACE DISTANCE TO SSP (km)	2111	1714	1164	824	508	301	141	0	
<b>Ground Transmitter</b>									
<b>TRANSMITTER FREQUENCY (MHz)</b>	<b>399.95</b>	<b>399.95</b>	<b>399.95</b>	<b>399.95</b>	<b>399.95</b>	<b>399.95</b>	<b>399.95</b>	<b>399.95</b>	
GROUND TRANSMITTER POWER (Watts)	3.0	3.0	3.0	3.0	3.0	3.0	3.0	3.0	
GROUND TRANSMITTER POWER (dB)	4.8	4.8	4.8	4.8	4.8	4.8	4.8	4.8	
TRANSMISSION LINE LOSS (dB)	1.5	1.5	1.5	1.5	1.5	1.5	1.5	1.5	
ANTENNA GAIN (dBi)	0.0	0.0	0.0	0.0	0.0	0.0	0.0	0.0	
GROUND TRANSMITTER EIRP (dBw)	3.3	3.3	3.3	3.3	3.3	3.3	3.3	3.3	
<b>Satellite Receiver</b>									
FREE SPACE LOSS (dB)	151.6	149.9	147.0	144.7	142.3	140.8	139.9	139.6	
ISOTROPIC POWER AT SAT ANTENNA (dB)	-148.3	-146.6	-143.7	-141.5	-139.0	-137.5	-136.6	-136.4	
SATELLITE RECEIVER ANTENNA GAIN (dBi)	0.0	0.0	0.0	0.0	0.0	0.0	0.0	0.0	
POLARIZATION LOSS (dB)	1.0	1.0	1.0	1.0	1.0	1.0	1.0	1.0	
IMPLEMENTATION LOSS (dB)	1.0	1.0	1.0	1.0	1.0	1.0	1.0	1.0	
SYSTEM NOISE TEMPERATURE (K)	400	400	400	400	400	400	400	400	
FRONT END GAIN (Ant Gain-Losses) (dB)	-2.0	-2.0	-2.0	-2.0	-2.0	-2.0	-2.0	-2.0	
FRONT END G/T (dB/K)	-28.0	-28.0	-28.0	-28.0	-28.0	-28.0	-28.0	-28.0	
BOLTZMAN'S CONSTANT (dB)	-228.6	-228.6	-228.6	-228.6	-228.6	-228.6	-228.6	-228.6	
UPLINK C/No (dB-Hz)	52.3	54.0	56.8	59.1	61.5	63.1	63.9	64.2	
DATA RATE (bps)	9600	9600	9600	9600	9600	9600	9600	9600	
Eb/No (dB)	12.5	14.1	17.0	19.3	21.7	23.3	24.1	24.4	
Eb/No REQUIRED FOR BER OF 10 <sup>-5</sup> (dB)	11.5	11.5	11.5	11.5	11.5	11.5	11.5	11.5	
<b>UPLINK MARGIN (dB)</b>	<b>1.0</b>	<b>2.6</b>	<b>5.5</b>	<b>7.8</b>	<b>10.2</b>	<b>11.8</b>	<b>12.6</b>	<b>12.9</b>	

Figure 11 Satellite Experimental UHF Uplink Budget

The UHF Experimental Payload downlink budget is shown in Figure 12.

<b>UHF</b>		<b>Downlink Budget</b>							<b>3/6/18</b>
<b>ELEVATION ANGLE TO SATELLITE (Deg)</b>	<b>5</b>	<b>10</b>	<b>20</b>	<b>30</b>	<b>45</b>	<b>60</b>	<b>75</b>	<b>90</b>	
ORBITAL ALTITUDE (km)	575	575	575	575	575	575	575	575	
EARTH'S RADIUS (km)	6378	6378	6378	6378	6378	6378	6378	6378	
COVERAGE HALF ANGLE TO HORIZON (Deg)	67	67	67	67	67	67	67	67	
SLANT RANGE TO SATELLITE (Km)	2268	1874	1343	1034	782	655	594	575	
SURFACE DISTANCE TO SSP (km)	2111	1714	1164	824	508	301	141	0	
<b>Satellite Transmitter</b>									
<b>SATELLITE DOWNLINK FREQUENCY (MHz)</b>	<b>400.60</b>	<b>400.60</b>	<b>400.60</b>	<b>400.60</b>	<b>400.60</b>	<b>400.60</b>	<b>400.60</b>	<b>400.60</b>	
TRANSMITTER OUTPUT POWER (Watts)	4.0	4.0	4.0	4.0	4.0	4.0	4.0	4.0	
TRANSMITTER OUTPUT POWER (dBw)	6.0	6.0	6.0	6.0	6.0	6.0	6.0	6.0	
IMPLEMENTATION LOSS (dB)	1.5	1.5	1.5	1.5	1.5	1.5	1.5	1.5	
SATELLITE TRANSMIT ANTENNA GAIN (dB)	0.0	0.0	0.0	0.0	0.0	0.0	0.0	0.0	
SATELLITE DOWNLINK EIRP (Watts)	2.8	2.8	2.8	2.8	2.8	2.8	2.8	2.8	
SATELLITE DOWNLINK EIRP (dBw)	4.5	4.5	4.5	4.5	4.5	4.5	4.5	4.5	
<b>Ground Receiver</b>									
FREE SPACE LOSS (dB)	151.6	149.9	147.0	144.7	142.3	140.8	139.9	139.6	
ISOTROPIC POWER AT ANTENNA (dBw)	-147.0	-145.4	-142.5	-140.2	-137.8	-136.3	-135.4	-135.1	
GROUND ANTENNA GAIN (dB)	0.0	0.0	0.0	0.0	0.0	0.0	0.0	0.0	
POLARIZATION LOSS (dB)	3.0	3.0	3.0	3.0	3.0	3.0	3.0	3.0	
TRANSMISSION LINE LOSS (dB)	1.0	1.0	1.0	1.0	1.0	1.0	1.0	1.0	
SYSTEM NOISE TEMPERATURE (K)	290	290	290	290	290	290	290	290	
FRONT END GAIN (Ant Gain-Losses) (dB)	-4.0	-4.0	-4.0	-4.0	-4.0	-4.0	-4.0	-4.0	
FRONT END G/T (dB/K)	-28.6	-28.6	-28.6	-28.6	-28.6	-28.6	-28.6	-28.6	
BOLTZMAN'S CONSTANT (dB)	-228.6	-228.6	-228.6	-228.6	-228.6	-228.6	-228.6	-228.6	
DOWNLINK C/No (dB-Hz)	52.9	54.6	57.5	59.8	62.2	63.7	64.6	64.9	
DATA RATE (bps)	9600	9600	9600	9600	9600	9600	9600	9600	
Eb/No (dB)	13.1	14.8	17.7	19.9	22.4	23.9	24.8	25.0	
Eb/No REQUIRED FOR GMSK BER of 10 <sup>-5</sup> (dB)	11.5	11.5	11.5	11.5	11.5	11.5	11.5	11.5	
<b>DOWNLINK MARGIN (dB)</b>	<b>1.6</b>	<b>3.3</b>	<b>6.2</b>	<b>8.4</b>	<b>10.9</b>	<b>12.4</b>	<b>13.3</b>	<b>13.5</b>	

Figure 12 Satellite Experimental UHF Downlink Budget

The VHF uplink budget is shown in Figure 13. The VHF uplink margin is in Figure 14.

<b>VHF</b>		<b>Uplink Budget</b>							2/26/18
<b>ELEVATION ANGLE TO SATELLITE (Deg)</b>		<b>5</b>	<b>10</b>	<b>20</b>	<b>30</b>	<b>45</b>	<b>60</b>	<b>75</b>	<b>90</b>
ORBITAL ALTITUDE (km)		575	575	575	575	575	575	575	575
EARTH'S RADIUS (km)		6378	6378	6378	6378	6378	6378	6378	6378
COVERAGE HALF ANGLE TO HORIZON (Deg)		67	67	67	67	67	67	67	67
SLANT RANGE TO SATELLITE (km)		2268	1874	1343	1034	782	655	594	575
SURFACE DISTANCE FROM RECEIVER TO SSP (km)		2111	1714	1164	824	508	301	141	0
<b>Ground Transmitter</b>									
<b>TRANSMITTER FREQUENCY (MHz)</b>		<b>145.9</b>	<b>145.9</b>	<b>145.9</b>	<b>145.9</b>	<b>145.9</b>	<b>145.9</b>	<b>145.9</b>	<b>145.9</b>
GROUND TRANSMITTER POWER (Watts)		10.0	10.0	10.0	10.0	10.0	10.0	10.0	10.0
GROUND TRANSMITTER POWER (dB)		10.0	10.0	10.0	10.0	10.0	10.0	10.0	10.0
TRANSMISSION LINE LOSS (dB)		1.5	1.5	1.5	1.5	1.5	1.5	1.5	1.5
ANTENNA GAIN (dBi)		8.0	8.0	8.0	8.0	8.0	8.0	8.0	8.0
GROUND TRANSMITTER EIRP (dBw)		16.5	16.5	16.5	16.5	16.5	16.5	16.5	16.5
<b>Satellite Receiver</b>									
FREE SPACE LOSS (dB)		142.8	141.1	138.2	136.0	133.5	132.0	131.1	130.9
ISOTROPIC POWER AT SATELLITE ANTENNA (dB)		-126.3	-124.6	-121.7	-119.5	-117.0	-115.5	-114.6	-114.4
SATELLITE RECEIVER ANTENNA GAIN (dBi)		0.0	0.0	0.0	0.0	0.0	0.0	0.0	0.0
POLARIZATION LOSS (dB)		3.0	3.0	3.0	3.0	3.0	3.0	3.0	3.0
IMPLEMENTATION LOSS (dB)		1.0	1.0	1.0	1.0	1.0	1.0	1.0	1.0
SYSTEM NOISE TEMPERATURE (K)		400	400	400	400	400	400	400	400
FRONT END GAIN (Ant Gain-Losses) (dB)		-4.0	-4.0	-4.0	-4.0	-4.0	-4.0	-4.0	-4.0
FRONT END G/T (dB/K)		-30.0	-30.0	-30.0	-30.0	-30.0	-30.0	-30.0	-30.0
BOLTZMAN'S CONSTANT (dB)		-228.6	-228.6	-228.6	-228.6	-228.6	-228.6	-228.6	-228.6
UPLINK C/No (dB-Hz)		72.3	73.9	76.8	79.1	81.5	83.1	83.9	84.2
DATA RATE (bps)		9600	9600	9600	9600	9600	9600	9600	9600
Eb/No (dB)		32.5	34.1	37.0	39.3	41.7	43.3	44.1	44.4
Eb/No REQUIRED FOR BER OF 10 <sup>-5</sup> (dB)		11.5	11.5	11.5	11.5	11.5	11.5	11.5	11.5
<b>UPLINK MARGIN (dB)</b>		<b>21.0</b>	<b>22.6</b>	<b>25.5</b>	<b>27.8</b>	<b>30.2</b>	<b>31.8</b>	<b>32.6</b>	<b>32.9</b>

Figure 13 Satellite VHF Uplink Budget

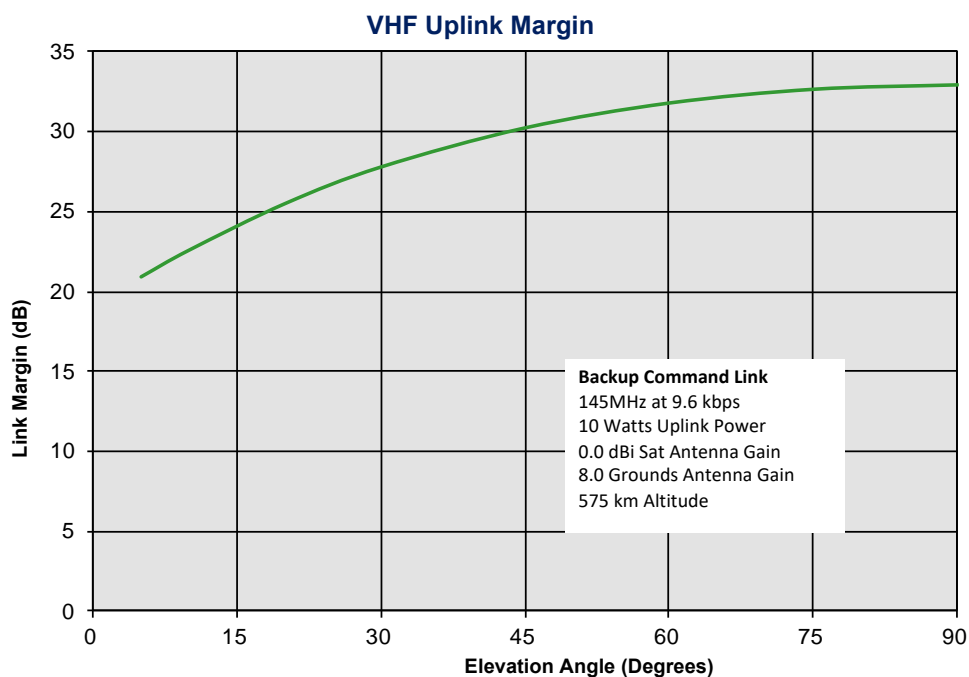

Figure 14 Satellite VHF Link Margins Vs. Elevation Angle

The satellite link margins for the UHF TT&C radio are plotted in *Figure 15*.

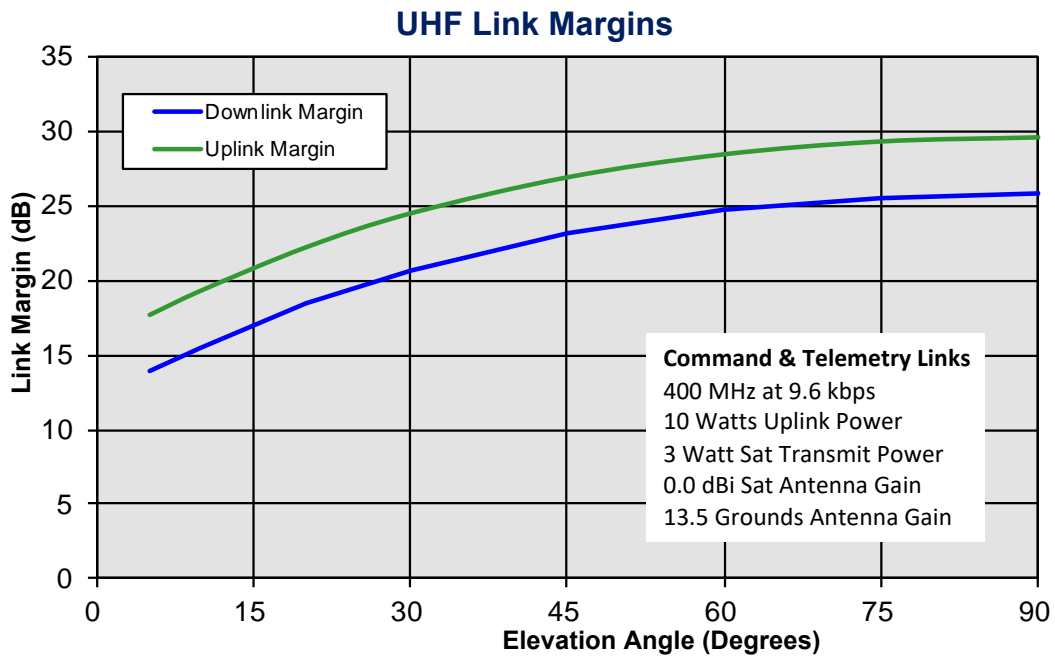

Figure 15 Satellite UHF TT&C Link Margins Vs. Elevation Angle

The satellite link margins for the S-Band radio are plotted in *Figure 16*.

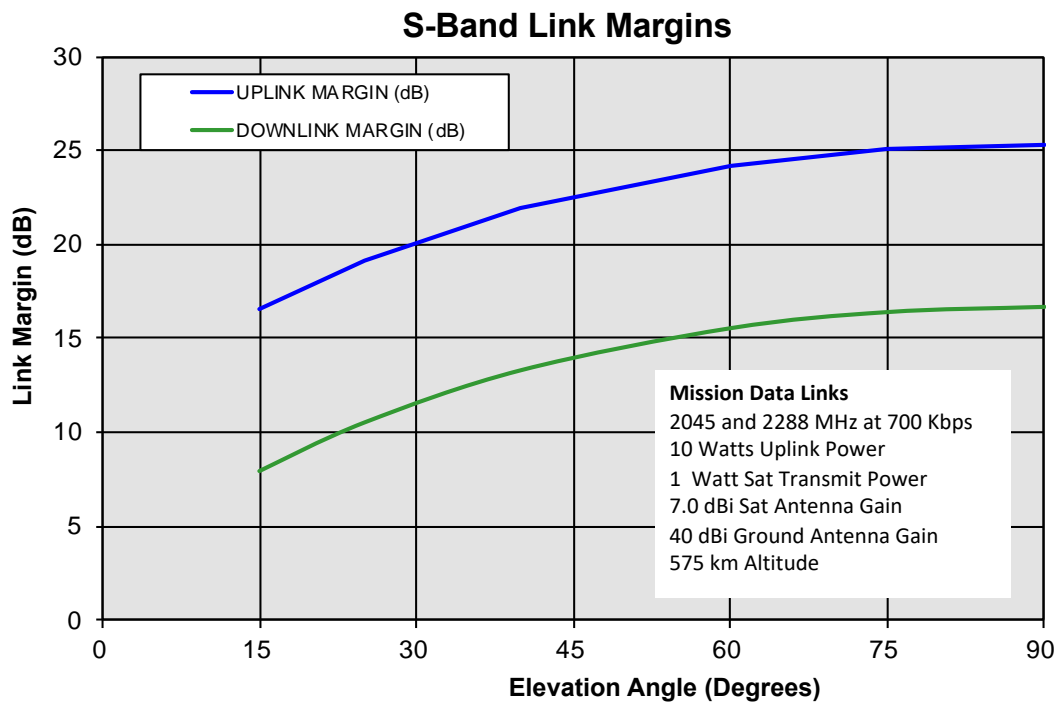

Figure 16 Satellite S-Band Link Margins Vs. Elevation Angle

The satellite link margins for the UHF Experimental Transceiver is plotted in *Figure 17*.

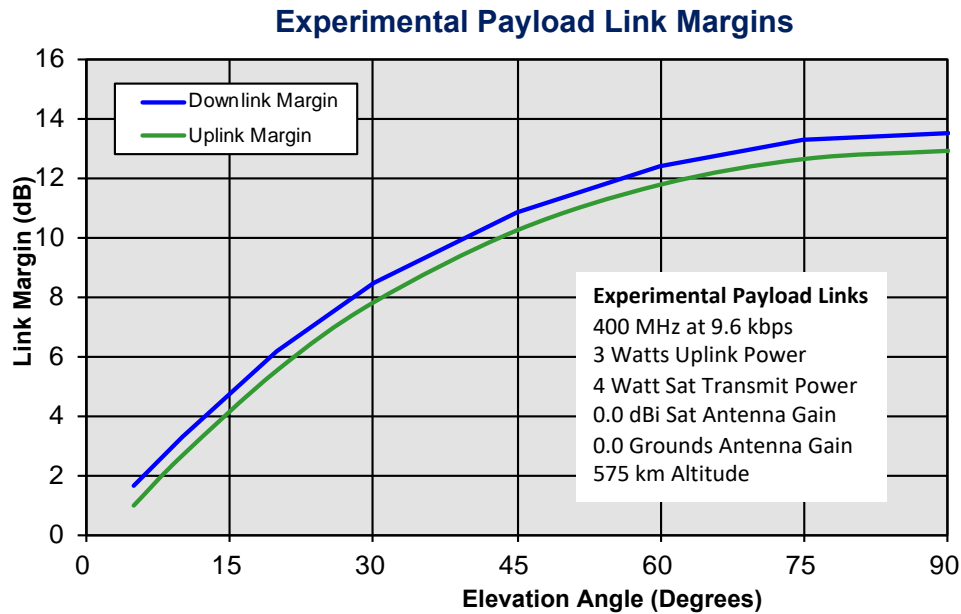

Figure 17 Satellite UHF Experimental Radio Link Margins Vs. Elevation Angle

## 11 Interference Analysis

### 11.1 400.50-400.65 MHz (TT&C and Experimental Downlink)

Interference with U.S. federal and commercial assignments in the 400.50-400.65 MHz band is unlikely as transmissions will only occur while over the SpaceQuest TT&C ground stations. The 400.50 to 400.65 MHz space-to-Earth band is allocated for UHF Little LEO data services and has been used experimentally by SpaceQuest for the past 5 years.

### 11.2 399.90 -400.05 MHz (TT&C and Experimental Uplink)

Interference with U.S. federal and commercial assignments in the 399.00-400.05 MHz band is unlikely as uplink transmissions will only occur while over the SpaceQuest TT&C ground stations. The 399.0-400.05 MHz Earth-to-space band is allocated for UHF Little LEO data services and has been used by SpaceQuest experimentally for the past 5 years.

### 11.3 2200-2290 MHz (Payload Downlink)

The GomSpaceSR2000 S-Band SDR Transmitter and ANT2000 Antenna is designed to operate in the 2200-2290 MHz band. In order to avoid interference with the U.S. Federal allocation in the 2200-2290 MHz band, all S-Band operations will occur outside of the United States.

The nominal S-Band downlink carrier frequency of 2288.5 MHz was selected for analysis for the BRIO satellite, but only a 1.0 MHz channel in the 2200-2290 MHz band will be used and coordinated with other authorized users of the band. S-Band downlink operations will occur several times each day at either Inuvik, Canada or Esrange, Sweden. Transmissions will be restricted as necessary to eliminate interference with other users of the band.

### 11.4 2025-2110 MHz (Payload Uplink)

SpaceQuest’s S-Band satellite receiver and antenna system is designed to operate in the 2025-2110 MHz band. The nominal S-Band uplink carrier frequency of 2045.5 MHz was chosen for analysis for the BRIO satellite, but only a 1.0 MHz channel in the 2025-2110 MHz band will be used and coordinated with other authorized users of the band.

The 2025-2110 MHz band was chosen for the BRIO experimental license because it is the only frequency band that can be supported with the chosen S-Band radio equipment – the GomSpaceSR2000 S-Band SDR Receiver and ANT2000 Antenna. In order to avoid interference with the U.S. Federal allocation in the 2025-2110 MHz band, all S-Band operations will occur outside of the United States.

Infrequent S-Band uplink transmissions from Inuvik, Canada or Esrange, Sweden, will be used to load new firmware to the BRIO satellite and to send confirmations of successful data packet downloads.

## 12 Power Flux Density Analysis

### 12.1 400.50-400.65 MHz (TT&C Downlink)

The Power Flux Density for the UHF TT&C downlink is shown in Figure 18.

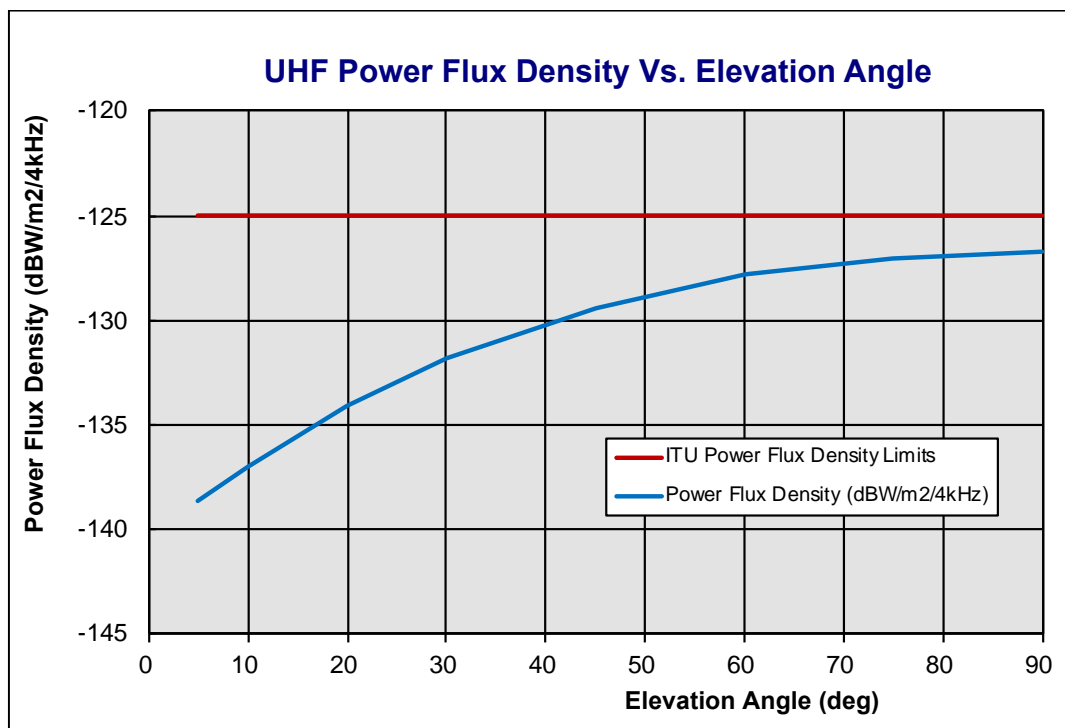

Figure 18 PFD at the Surface of the Earth for the UHF Transmitter



12.2 2200-2290 MHz (S-Band Downlink)

The PFD for the S-Band downlink satisfies the ITU PFD limits as shown in Figure 19.

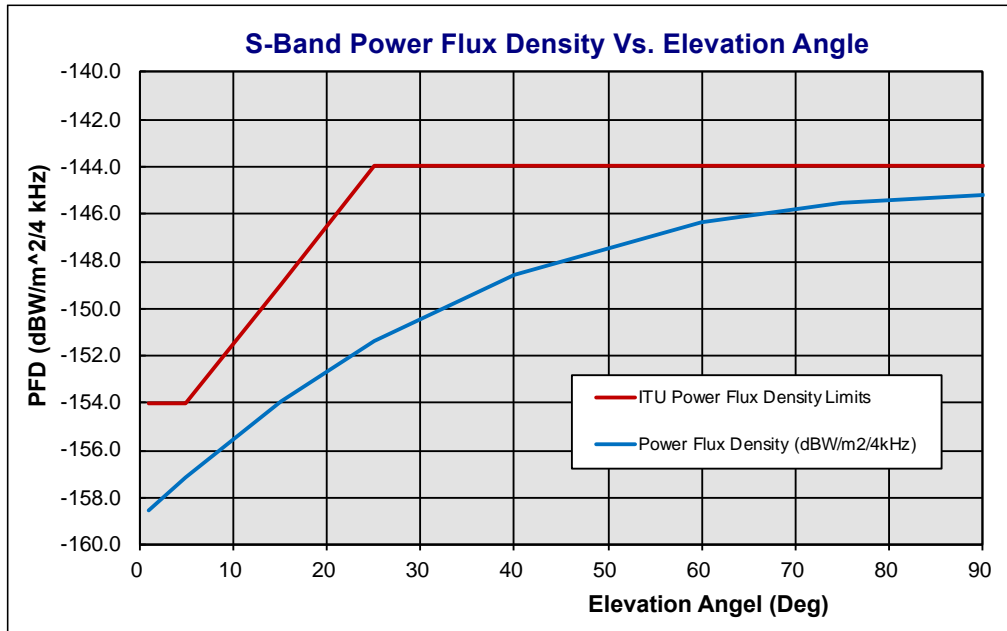

Figure 19 PFD at the Surface of the Earth for the S-Band Transmitter

12.3 400.50-400.65 MHz (Experimental Payload Downlink)

The Power Flux Density for the UHF Experimental Payload downlink is shown in Figure 20.

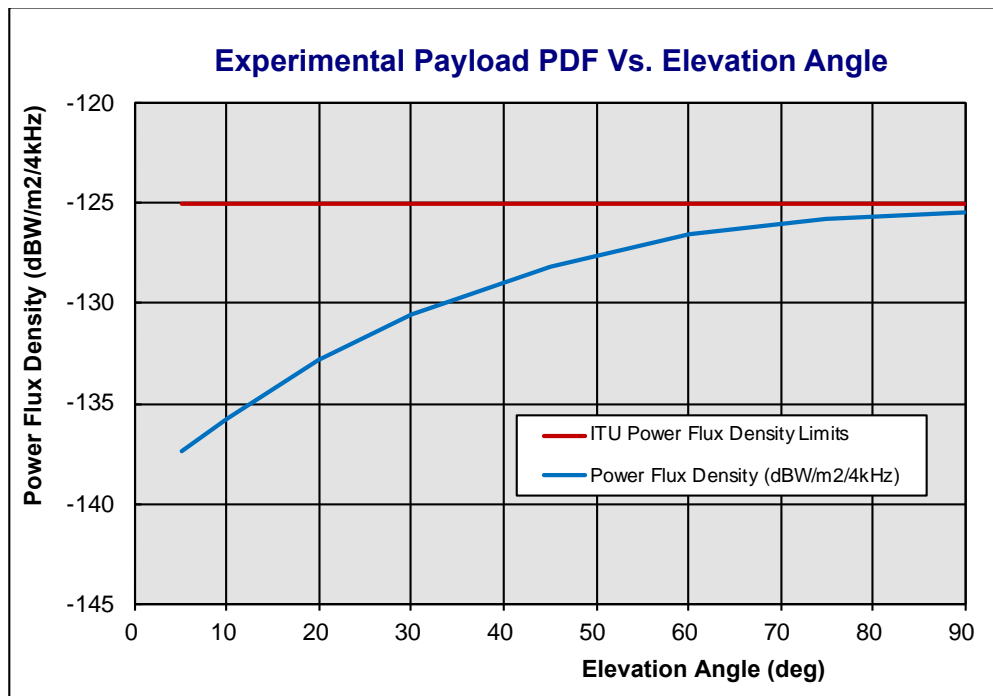

Figure 20 PFD at the Surface of the Earth for the UHF Payload Transmitter

### 13 Space Station Antenna Radiation Patterns

#### 13.1 S-Band: BRIO Space Station Transmit/Receive Antenna

The GomSpace NanoCom ANT2150 side-mounted S-Band Patch Antenna is used to downlink the BRIO mission data. This circularly-polarized antenna incorporates an LNA designed to receive in the 2025-2110 MHz frequency band, and a Power Amplifier designed to transmit in the 2200-2290 MHz frequency band. The radiation pattern is shown in Figure 21.

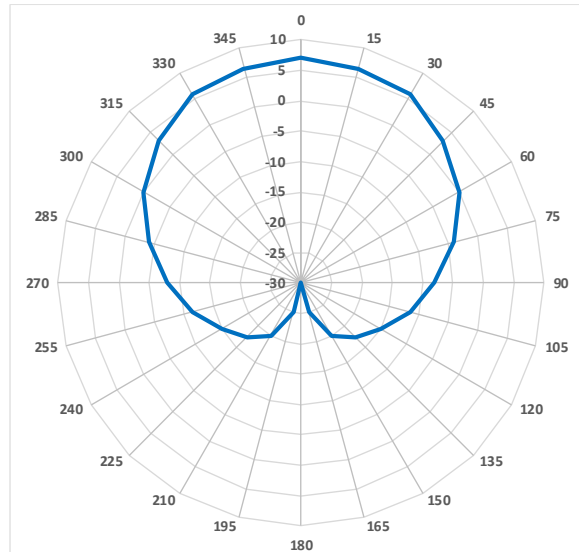

Figure 21 S-Band Satellite Transmit/Receive Antenna Radiation Pattern

#### 13.2 UHF: BRIO Space Station TT&C Transmit/Receive Antenna

An ISIS Deployable Omnidirectional UHF Monopole Antenna System is used to uplink and downlink TT&C data. It has a 0 dBi average gain and a radiation pattern shown in Figure 22.

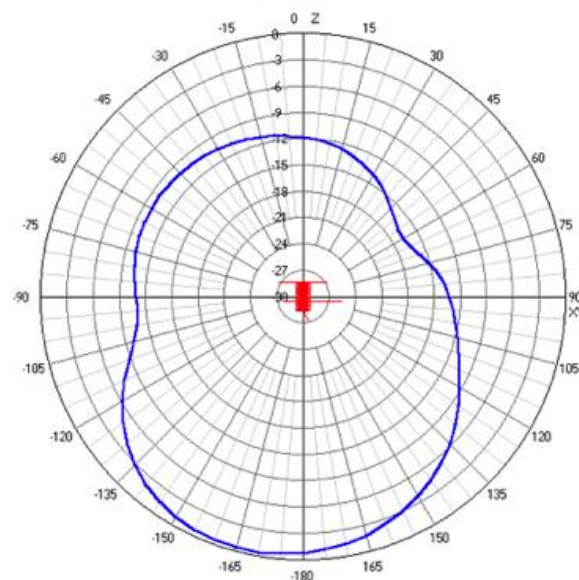
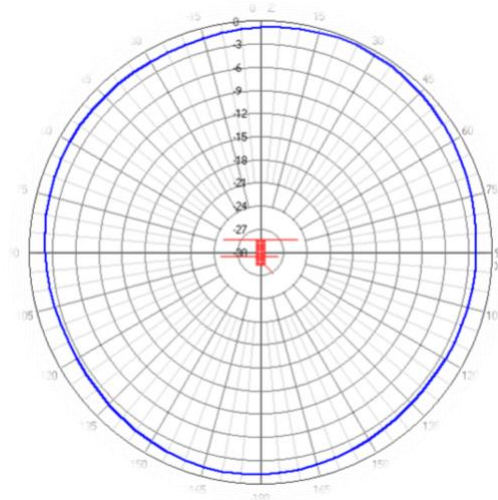

Figure 22 TT&C UHF Satellite Transmit/Receive Antenna Radiation Pattern.

### 13.3 VHF: BRIO Space Station Receive Antenna

The same ISIS Deployable Omnidirectional Antenna has a VHF monopole element, which is used to receive emergency commands to reboot the flight computer or to power cycle the spacecraft in the event of a single event latch up. This small, sensitive, very low-power receiver design that operates at a different, fixed frequency than the primary UHF TT&C receiver can save a mission. SpaceQuest will perform sensitivity tests of the receiver in order to characterize its performance in the space environment. The omni-directional radiation pattern is shown in *Figure 23*.



*Figure 23 VHF Satellite Receive Antenna Radiation Pattern*

### 13.4 UHF: BRIO Space Station Experimental UHF Receive/Transmit Antenna

An UHF Experimental Transceiver developed by SpaceQuest to investigate the performance of Myriota's novel protocol and processing algorithms is shown in *Figure 24*.

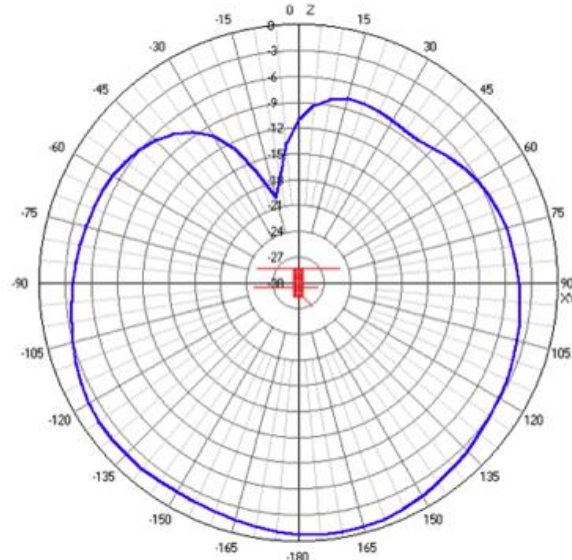

*Figure 24 Experimental UHF Satellite Transmit/Receive Antenna Radiation Pattern*

### 13.5 Summary of BRIO Antenna Characteristics

Figure 25 lists the antenna parameters for the four BRIO antennas.

<b>Antenna Parameter</b>	<b>S-Band</b>	<b>UHF</b>	<b>VHF</b>	<b>UHF Payload</b>
Frequency Range:	2025-2290 MHz	399.9-400.65 MHz	145.92 MHz	399.9-400.65 MHz
Bandwidth Required:	1,000 KHz	150 KHz	25 KHz	150 KHz
Emission Designator:	1M00G1D	35K0F1D	20K0F1D	35K0F1D
Number of Channels:	1	1	1	1
Space Station Class:	EH	ET	ED	EH
Beam Name:	SBTX and SBRX	UTX and URX	VRX	EXTX and EXRX
Emission/Receive	E/R	E/R	R	E/R
Max ISO. Gain	7.0 dBi	0.0 dBi	0.0 dBi	0.0 dBi
Antenna Type:	Patch	Monopole	Monopole	Monopole
Polarization:	Circular	Linear	Linear	Linear
Peak Power:	1.0 Watts	3.0 Watts	Receive Only	4.0 Watts
Antenna Pattern:	See Figure 21	See Figure 22	See Figure 23	See Figure 24
Link Margin:	See Figure 16	See Figure 15	Receive Only	See Figure 17
Power Flux Density:	Within ITU limits. See Figure 19	Within ITU limits. See Figure 18	Receive Only	Within ITU limits. See Figure 20

Figure 25 BRIO Antenna Characteristics

## 14 Earth Station Antenna Radiation Patterns

The antenna pattern for SpaceQuest’s UHF Earth Stations are provided in Figure 26.

### 14.1 UHF TT&C Antennas in Fairfax, VA, North Pole, AK, Naalehu, HI and Limestone, ME

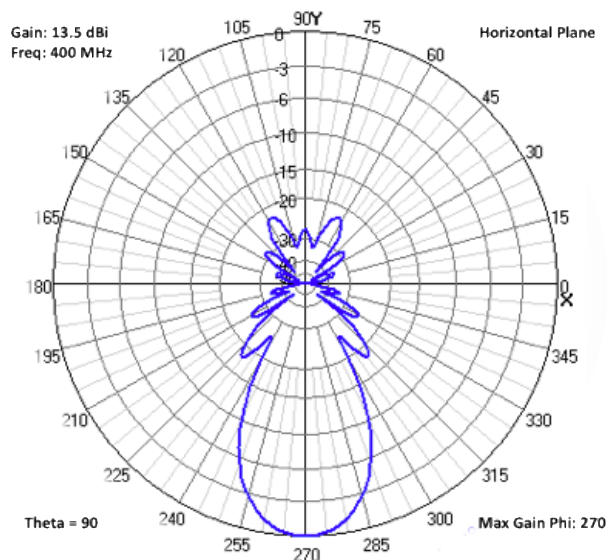

Figure 26 UHF Earth Station Antenna Radiation Pattern.

### 14.2 VHF Backup Antennas in Fairfax, VA, North Pole, AK, Naalehu, HI and Limestone, ME

The antenna patterns for SpaceQuest’s VHF Earth Stations are provided in Figure 27.

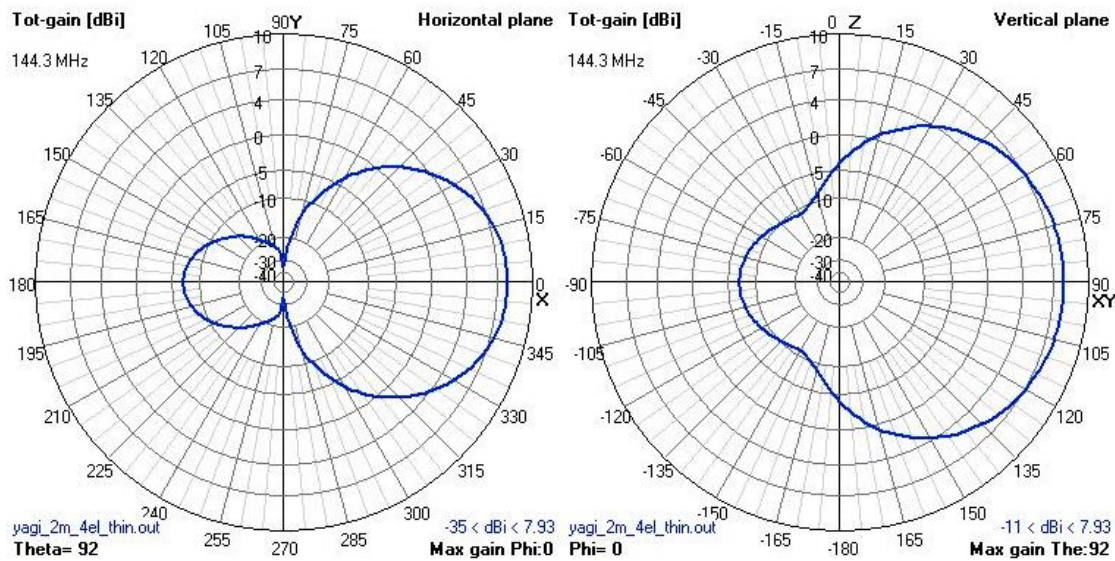

Figure 27 VHF Earth Station Antenna Radiation Pattern.

### 14.3 S-Band Antennas in Inuvik, Canada and Esrange, Sweden

SpaceQuest’s S-Band antennas in Inuvik, Canada and Esrange, Sweden are for downloading the data captured by the Myriota payload. Only the Esrange S-Band antenna will be used to upload new firmware to the satellite. An S-Band radiation pattern for these antennas is shown in Figure 28

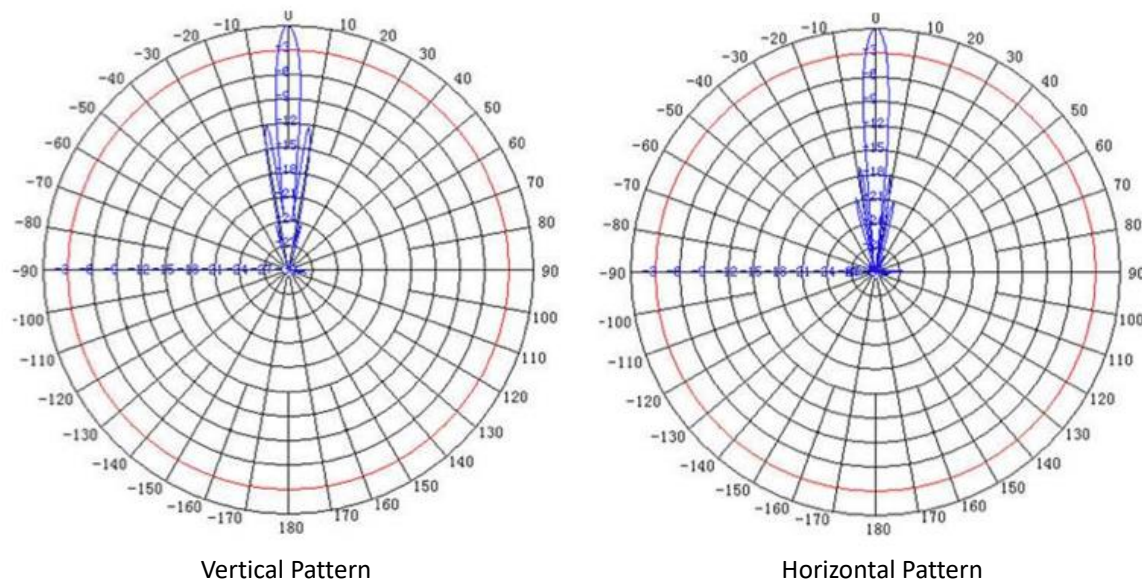

Figure 28 S-Band Earth Station Antenna Radiation Pattern

#### 14.4 UHF Experimental Antenna

The radiation pattern for the omni-directional transceiver antenna that communicates with the UHF experimental payload on BRIO is depicted in Figure 29.

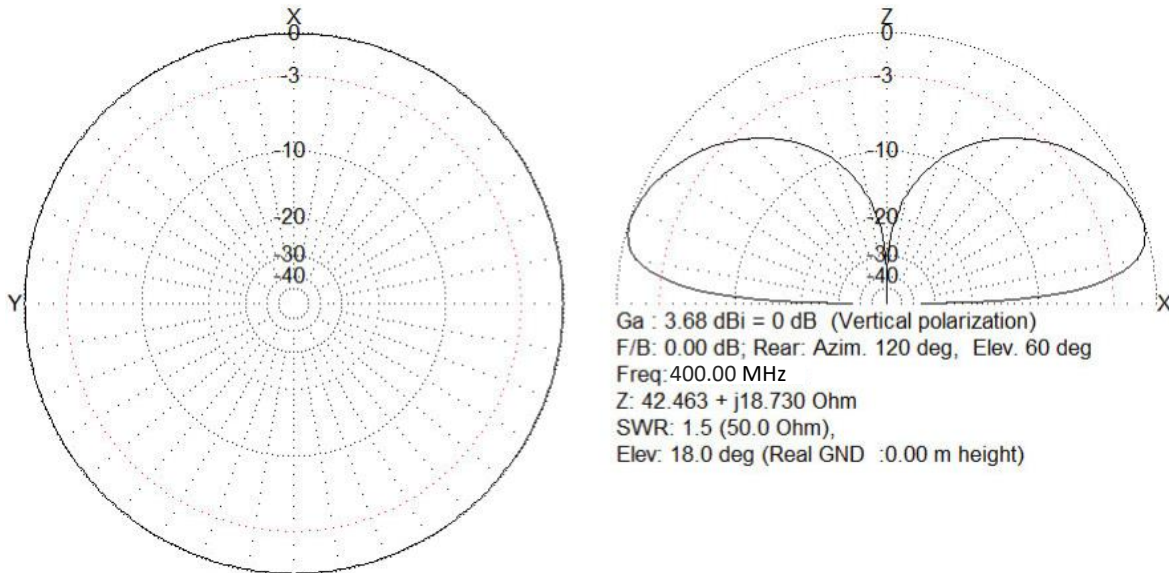

Figure 29 UHF Experimental Earth Station Antenna Radiation Pattern

#### 15 Stop Buzzer POC

The 24-hour SpaceQuest contact for interference issues is provided below:

Name: Glenn Richardson  
Email: [glenn@spacequest.com](mailto:glenn@spacequest.com)  
Tel: 703-424-7806