

### **Vcom Radio - Description of Equipment - Introduction**

The VHF COM radio provides the VHF transceiver functions of VHF voice communications when connected to external power, an antenna, and a display.

The VHF COM radio will be developed to meet the Federal Aviation Administration (FAA) Radio Communications TSO-C169a VHF Radio Communications Transceiver Equipment Operating Within the Radio Frequency Range 117.975 To 137 Megahertz.

The VHF COM radio functions will be developed to meet the RTCA/DO-186B Minimum Operational Performance Standards (MOPS) for Airborne Radio Communications Equipment Operating Within the Radio Frequency Range 117.975 – 137.000 MHz.

The radio tunes the requested frequency, provides received audio to external audio systems, accepts audio to be transmitted and transmitter keyline from the external systems, and reports the transmitter and receiver status and health.

### **Description of Equipment - Specifications**

Frequency Range:	Per FAA TSO-C169a and RTCA/DO-186B 118.0 to 137.000 Mhz, supporting 50, 25, or 8.33Khz channel spacing.
Tune Time	Less than 20ms from receive of CAN tune message.
Receiver Sensitivity	10 uV (-93 dBm) for an audio SNR of 6 dB. Maximum input 100mV (-13 dBm)
Environmental:	Capability to highest of Helicopter and Jet DO-160G.
Temp/Altitude	-40 - +70 DegF operating to 55,000 Feet
Input Voltage	11 - 33 volts DC
Current Limit	3 Amperes, maximum
Data:	3x CAN buses
Antenna:	50 ohm; VSWR < 3:1 per RTCA/DO-186B
Normal Audio:	Mic level input CAN PTT Rx Audio at Line Level Alerting audio not used
Mic/Line Level	0.5v/1.0 Vrms, determined by Audio System specification
Emergency Audio:	Mic Level Input Mic PTT discrete Rx Audio out direct headphone drive Alerting audio mixed into headphone outputs
Transmitter Duty Cycle:	10%, 4.5 minutes receive, 0.5 minute transmit
AM Modulation Index	70% minimum; 90% nominal
Carrier Transmit Power:	Min 16 Watts across all frequencies Instantaneous Peak 64.8 Watts at 80% modulation

**Description of Equipment - System Description**

The following high level interface diagram illustrates the inputs and outputs for the radio. The major components depicted in the figure VHF COM Radio Block Diagram are:

- RF Front End

The RF front end consists of a Transmit/Receive switch, one receiver-conversion path, and an RF Power Amplifier with a modulator.

- ADC

The ADC produces a digital signal output for the VHF COM FPGA

- FPGA

The FPGA contains the receive signal processing path for VHF COM. The FPGA is also responsible for controlling the frequency synthesizers and attenuators in the RF Front end.

- MCU

The MCU accepts and processes digital sample streams at 39.0625 k samples/sec from the VHF COM FPGA. The microprocessor also implements AGC functionality by controlling the RF attenuators in the RF Front End.

- The VHF COM Codec encodes and decodes audio.

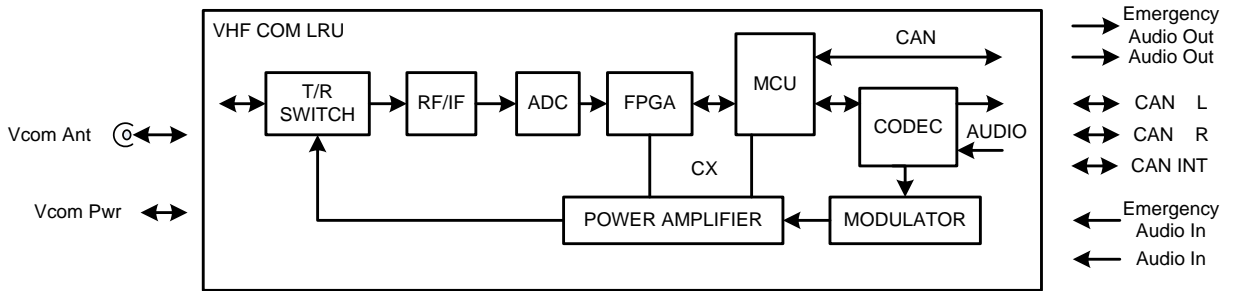

**VHF COM Radio Block Diagram**

## Hardware Description – Theory of Operation

The VHF COM radio is a circuit card including several functions:

- VHF communication transceiver (a transmit chain and a receive chain)
- DC Power conditioning and control

Two audio streams supplying the transceiver communication functions are depicted in the figure VHF COM Radio Hardware Block Diagram, along with the power supply functions.

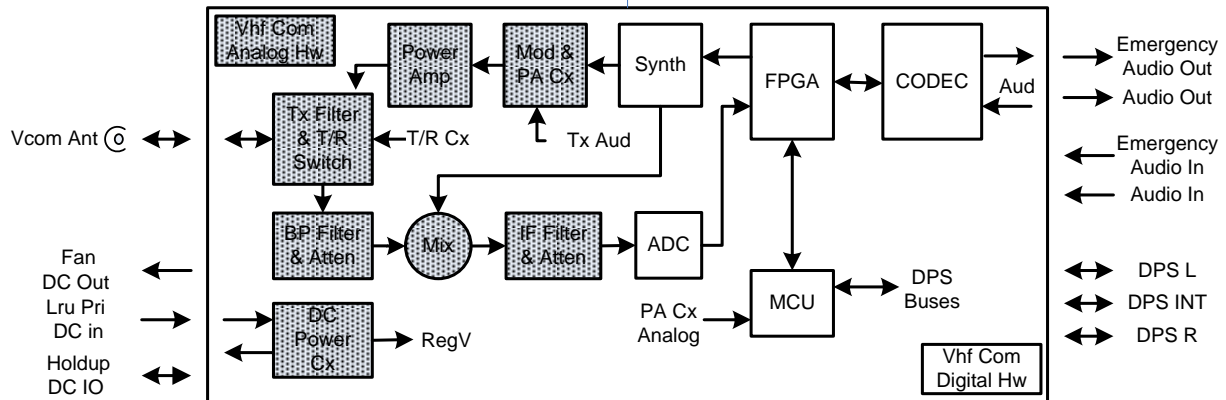

Figure VHF COM Radio Hardware Block Diagram

### RF/IF – VHF COM

The receive path accepts an RF signal from the Transmit/Receive switch. The RF hardware applies gains specified by the MCU, performs IF down conversion and conditions the signal (filtering and dither addition) for the Analog to Digital Converter (ADC).

### ADC – VHF COM

The ADC samples the IF at 80 MHz, converting the signal into 10-bit digital samples.

### FGPA – VHF COM

The FPGA performs down conversion and decimation. The signal result from the FPGA is an I and Q complex baseband signal centered at DC and sampled at 39.0625 kHz. The bandwidth of the signal from the FPGA is 16 kHz.

### MCU – VHF COM

The MCU accepts the 24-bit sample stream at 39.0625 k samples/sec from the FPGA. Signal processing in the MCU includes conversion to floating point, filtering, AGC processing, squelch processing, demodulating the AM, filtering and presenting the digital audio to the Codec.

### Software Description – Theory of Operation

The following diagram VHF COM Radio Software Operations depicts receive data processing elements. The focal point of the hardware system is the FPGA. It interfaces with the transceiver hardware components: synthesizer, attenuator, amplifier, dither, and ADC sampler. The FPGA samples the receive radio signal, filters and outputs a data stream requiring additional software Digital Signal Processing (DSP). The software DSP produces Com Rx audio and computes the required gain and attenuation used by the FPGA and Codecs. Tuned frequency and audio output selections are specified by incoming system data-bus messages.

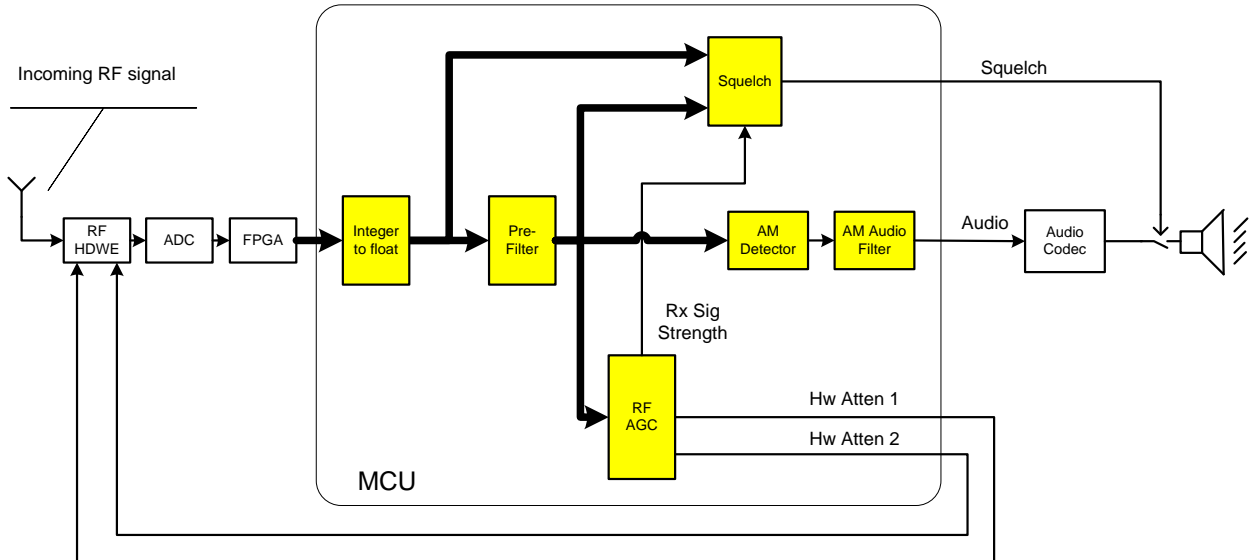

**VHF COM Radio Software Operations**